

# Public Document Pack

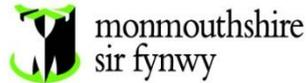

County Hall  
Rhadyr  
Usk  
NP15 1GA

Tuesday, 16 July 2024

Notice of meeting :

## Place Scrutiny Committee

Wednesday, 24th July, 2024 at 4.30 pm,  
Council Chamber, County Hall, The Rhadyr USK

Please note that a pre-meeting with Committee Members will be held 30 minutes before the main meeting

### AGENDA

Item No	Item	Pages
1.	Apologies for Absence	
2.	Declarations of Interest	
3.	Public Open Forum	
	<b>Scrutiny Committee Public Open Forum ~ Guidance</b>	
	Our Scrutiny Committee meetings are live streamed and a link to the live stream will be available on the meeting page of the Monmouthshire County Council <a href="#">website</a>	
	If you would like to share your thoughts on any proposals being discussed by Scrutiny Committees, you can submit your representation in advance <a href="#">via this form</a>	
	Please share your views by uploading a video or audio file (maximum of 4 minutes) or; Please submit a written representation (via Microsoft Word, maximum of 500 words)	

You will need to register for a [My Monmouthshire account](#) in order to submit the representation or use your log in, if you have registered previously.

The deadline for submitting representations to the Council is 5pm three clear working days in advance of the meeting.

If representations received exceed 30 minutes, a selection of these based on theme will be shared at the Scrutiny Committee meeting. All representations received will be made available to councillors prior to the meeting.

If you would like to attend one of our meetings to speak under the Public Open Forum at the meeting, you will need to give three working days' notice by contacting [Scrutiny@monmouthshire.gov.uk](mailto:Scrutiny@monmouthshire.gov.uk).

The amount of time afforded to each member of the public to speak is at the chair's discretion, but to enable us to accommodate multiple speakers, we ask that contributions be no longer than 3 minutes.

If you would like to suggest future topics for scrutiny by one of our Scrutiny Committees, please do so by emailing [Scrutiny@monmouthshire.gov.uk](mailto:Scrutiny@monmouthshire.gov.uk)

**4. Proposals for Gypsy and Travellers**

Pre-decision Scrutiny of proposals

**5. Next Meeting: 3rd September 2024 (Special) and 10th October 2024.**

1 - 862

**Paul Matthews**

**Chief Executive**

MONMOUTHSHIRE COUNTY COUNCIL  
CYNGOR SIR FYNWY

THE CONSTITUTION OF THE COMMITTEE IS AS FOLLOWS:

County Councillor Louise Brown	Shirenewton;	Welsh Conservative Party
County Councillor Emma Bryn	Wyesham;	Independent Group
County Councillor Tomos Dafydd Davies	Llanfoist & Govilon;	Welsh Conservative Party
County Councillor Lisa Dymock	Portskewett;	Welsh Conservative Party
County Councillor Jane Lucas	Osbaston;	Welsh Conservative Party
County Councillor Jackie Strong	Caldicot Cross;	Welsh Labour/Llafur Cymru
County Councillor Laura Wright	Grofield;	Welsh Labour/Llafur Cymru
County Councillor Tudor Thomas	Park;	Welsh Labour/Llafur Cymru
County Councillor John Crook	Magor East with Undy;	Welsh Labour/Llafur Cymru

## Public Information

### Access to paper copies of agendas and reports

A copy of this agenda and relevant reports can be made available to members of the public attending a meeting by requesting a copy from Democratic Services on 01633 644219. Please note that we must receive 24 hours notice prior to the meeting in order to provide you with a hard copy of this agenda.

### Welsh Language

The Council welcomes contributions from members of the public through the medium of Welsh or English. We respectfully ask that you provide us with adequate notice to accommodate your needs.

# Aims and Values of Monmouthshire County Council

## Our purpose

To become a zero-carbon county, supporting well-being, health and dignity for everyone at every stage of life.

## **Objectives we are working towards**

- Fair place to live where the effects of inequality and poverty have been reduced.
- Green place to live and work with reduced carbon emissions and making a positive contribution to addressing the climate and nature emergency.
- Thriving and ambitious place, where there are vibrant town centres and where businesses can grow and develop.
- Safe place to live where people have a home where they feel secure in.
- Connected place where people feel part of a community and are valued.
- Learning place where everybody has the opportunity to reach their potential.

## Our Values

**Openness.** We are open and honest. People have the chance to get involved in decisions that affect them, tell us what matters and do things for themselves/their communities. If we cannot do something to help, we'll say so; if it will take a while to get the answer we'll explain why; if we can't answer immediately we'll try to connect you to the people who can help – building trust and engagement is a key foundation.

**Fairness.** We provide fair chances, to help people and communities thrive. If something does not seem fair, we will listen and help explain why. We will always try to treat everyone fairly and consistently. We cannot always make everyone happy, but will commit to listening and explaining why we did what we did.

**Flexibility.** We will continue to change and be flexible to enable delivery of the most effective and efficient services. This means a genuine commitment to working with everyone to embrace new ways of working.

**Teamwork.** We will work with you and our partners to support and inspire everyone to get involved so we can achieve great things together. We don't see ourselves as the 'fixers' or problem-solvers, but we will make the best of the ideas, assets and resources available to make sure we do the things that most positively impact our people and places.

**Kindness:** We will show kindness to all those we work with putting the importance of relationships and the connections we have with one another at the heart of all interactions.

## Monmouthshire Scrutiny Question Guide

### Role of the Pre-meeting

1. Why is the Committee scrutinising this? (background, key issues)
2. What is the Committee's role and what outcome do Members want to achieve?
3. Is there sufficient information to achieve this? If not, who could provide this?

- Agree the order of questioning and which Members will lead
- Agree questions for officers and questions for the Cabinet Member

### Questions for the Meeting

#### Scrutinising Performance

1. How does performance compare with previous years? Is it better/worse? Why?
2. How does performance compare with other councils/other service providers? Is it better/worse? Why?
3. How does performance compare with set targets? Is it better/worse? Why?
4. How were performance targets set? Are they challenging enough/realistic?
5. How do service users/the public/partners view the performance of the service?
6. Have there been any recent audit and inspections? What were the findings?
7. How does the service contribute to the achievement of corporate objectives?
8. Is improvement/decline in performance linked to an increase/reduction in resource? What capacity is there to improve?

#### Scrutinising Policy

1. Who does the policy affect ~ directly and indirectly? Who will benefit most/least?
2. What is the view of service users/stakeholders? What consultation has been undertaken? Did the consultation process comply with the Gunning Principles? Do stakeholders believe it will achieve the desired outcome?
3. What is the view of the community as a whole - the 'taxpayer' perspective?
4. What methods were used to consult with stakeholders? Did the process enable all those with a stake to have their say?
5. What practice and options have been considered in developing/reviewing this policy? What evidence is there to inform what works? Does the policy relate to an area where there is a lack of published research or other evidence?
6. Does the policy relate to an area where there are known inequalities?
7. Does this policy align to our corporate

	<p>objectives, as defined in our corporate plan? Does it adhere to our Welsh Language Standards?</p> <p>8. Have all relevant sustainable development, equalities and safeguarding implications</p> <p>9. been taken into consideration? For example, what are the procedures that need to be in place to protect children?</p> <p>10.</p> <p>11. How much will this cost to implement and what funding source has been identified?</p> <p>12.</p> <p>13. How will performance of the policy be measured and the impact evaluated</p>
--	--

**General Questions:**

- Empowering Communities
- How are we involving local communities and empowering them to design and deliver services to suit local need?
  - Do we have regular discussions with communities about service priorities and what level of service the council can afford to provide in the future?
  - Is the service working with citizens to explain the role of different partners in delivering the service, and managing expectations?
  - Is there a framework and proportionate process in place for collective performance assessment, including from a citizen’s perspective, and do you have accountability arrangements to support this?
  - Has an Equality Impact Assessment been carried out? If so, can the Leader and Cabinet/Senior Officers provide members with copies and a detailed explanation of the EQIA conducted in respect of these proposals?
  - Can the Leader and Cabinet/Senior Officers assure members that these proposals comply with Equality and Human Rights legislation? Do the proposals comply with the Local Authority’s Strategic Equality Plan?
- Service Demands
- How will policy and legislative change affect how the council operates?
  - Have we considered the demographics of our council and how this will impact on service delivery and funding in the future?
  - Have you identified and considered the long-term trends that might affect your service area, what impact these trends could have on your service/your service could have on these trends, and what is being done in response?
- Financial Planning
- Do we have robust medium and long-term financial plans in place?
  - Are we linking budgets to plans and outcomes and reporting effectively on these?

*Making savings and generating income*

- Do we have the right structures in place to ensure that our efficiency, improvement and transformational approaches are working together to maximise savings?
- How are we maximising income?
- Have we compared other council's policies to maximise income and fully considered the implications on service users?
- Do we have a workforce plan that takes into account capacity, costs, and skills of the actual versus desired workforce?

*Questions to ask within a year of the decision:*

- Were the intended outcomes of the proposal achieved or were there other results?
- Were the impacts confined to the group you initially thought would be affected i.e. older people, or were others affected e.g. people with disabilities, parents with young children?
- Is the decision still the right decision or do adjustments need to be made?

**Questions for the Committee to conclude...**

Do we have the necessary information to form conclusions/make recommendations to the executive, council, other partners? If not, do we need to:

- (i) Investigate the issue in more detail?
- (ii) Obtain further information from other witnesses – Executive Member, independent expert, members of the local community, service users, regulatory bodies...

Agree further actions to be undertaken within a timescale/future monitoring report...





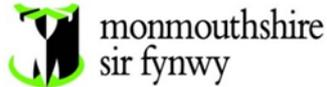

**SUBJECT: MEETING GYPSY AND TRAVELLER PITCH NEEDS – SITE IDENTIFICATION PROPOSAL**  
**MEETING: PLACE SCRUTINY COMMITTEE**  
**DATE: 24<sup>TH</sup> JULY 2024**  
**DIVISION/WARDS AFFECTED: ALL**

## 1. PURPOSE

- 1.1 To consider the findings of a public consultation and site investigation surveys on the suitability of three pieces of Council owned land - Langley Close, Magor; Bradbury Farm, Crick and Oakgrove, Portskewett (**see Appendix 1**) for possible development as Gypsy and Traveller sites and inclusion in the Council's Deposit Replacement Local Development Plan (RLDP).
- 1.2 Informed by the public consultation and site investigation surveys, the report also proposes that land at Bradbury Farm, Crick is considered as the preferred option for development as a Gypsy & Traveller site. It is, therefore, proposed that Bradbury Farm is put forward for inclusion in the Deposit RLDP. The site would then form part of a detailed public consultation on the Deposit RLDP where people will be able to comment further on the proposal to allocate this land to meet the Council's Gypsy and Traveller housing need.

## 2. RECOMMENDATIONS:

- 2.1 To consider the following recommendation by the Cabinet Member for Planning and Economic Development Deputy Leader:
  - To remove Langley Close, Magor and Oakgrove, Portskewett from the site identification process as key information, findings and evidence from public consultation and site investigation surveys has indicated that these sites are deemed less suitable. **See Paragraphs 3.3.2 and 3.3.3 for further detail.** Furthermore, these sites are not needed at present due to the pitch requirement reducing to seven (**See Paragraph 3.3.1**)
  - To approve the use of Bradbury Farm, Crick for proposed Gypsy and Traveller site development and inclusion in the Deposit RLDP (**see Paragraph 3.3.4**), subject to the outcome of provisional and indicative design work and the findings and recommendations of further site evaluation survey work in respect of noise mitigation.

## 3. KEY ISSUES:

### 3.1 The Council's Statutory Obligations

#### Gypsy and Traveller Assessment

- 3.1.1 All Councils in Wales have a duty under Part 3, Housing (Wales) Act 2014 to undertake a Gypsy, Roma and Traveller Assessment every five years. Where unmet need for mobile home pitches is identified, the necessary pitch provision needs to be facilitated. The last Gypsy, Roma and Traveller Assessment was adopted by Cabinet on 6<sup>th</sup>

January 2021. The summary conclusions identify a need for 13 pitches for families already living within Monmouthshire. This was approved by Welsh Government in June 2024. This need is broken down as follows:

- An unmet need of nine pitches under the assessment period 2020 to 2025;
- Beyond 2025, a further unmet need of four pitches over the remaining length of the Replacement Local Development Plan (2026-33) to accommodate family growth as children become adults and require their own pitch;
- No need was identified for travelling show people or circus people;
- The Assessment did not identify a need to provide a transit site and given the cross-border movement associated with families passing through local authorities, this topic is best addressed via the regional Strategic Development Plan.

3.1.2 Of the thirteen pitches needed as identified by the 2020-2025 Gypsy and Traveller Assessment, two pitches have been granted planning permission for a family that was part of the GGTA. This reduced the pitch requirement to 11. The decision by the Planning Committee on 16th July 2024 to approve a further four pitches, reduces the overall pitch requirement further to seven.

### **Replacement Local Development Plan (RLDP)**

3.1.3 The Council is required to produce a Local Development Plan which sets out the Council's vision for the development and use of land in the County. The current plan was adopted in 2014 and to ensure the Plan is kept up to date, the Council has commenced preparation of the Replacement Local Development Plan 2018 – 2033 (the RLDP).

3.1.4 As required by Welsh Government, the RLDP **must** allocate land to meet its housing needs, including the identified need for Gypsy, Roma and Traveller pitches. Failure of the Council to do so will impact detrimentally on the adoption and delivery of the wider plan, which will have economic and social consequences for the County. For example, it would impact detrimentally on future house building.

## **3.2 Process to Date**

3.2.1 The Council has implemented a process to evaluate all Council owned land i.e. 1500 assets, to meet the identified pitch need and provide suitable homes in a sustainable location to identified local Gypsy and Traveller families, that require a home within the county. The vision is for:

- Small sites, ideally occupied by one Monmouthshire family/household;
- Typically, no more than 5 or 6 pitches on each site;
- Well designed and landscaped;
- Sensitive to existing communities.

3.2.2 An overview of the site identification process undertaken, and criteria used is provided in **Appendix 2**, which included engagement with elected members through a series of member workshops and Scrutiny Committees, to share requirements, obtain views/comments about the process and evaluation criteria and update on progress.

### **The RAG Evaluation**

3.2.3 The Council's site identification process has reviewed and evaluated all the Council's 1500 assets. The core of the process was a broad five staged exercise to sift

out/remove unsuitable land using site evaluation criteria, the aim being to identify a short-list of land with potential suitability for development as Gypsy and Traveller pitch provision, which would then be consulted upon.

- 3.2.4 This staged exercise to sift out unsuitable assets has been recorded and evidenced in a document, referred to as the RAG document (a spreadsheet that utilises a traffic-light system of red, amber and green to colour code evaluation findings and provide a more visual indication/overview). The RAG document was an iterative document that was continually updated as and when new information was identified. **See Appendix 3.** This staged process and the RAG document informed the original proposal scrutinised by People Scrutiny Committee held on the 19<sup>th</sup> of July and the report on the Cabinet agenda on 26<sup>th</sup> July 2023.

#### **Cabinet 4<sup>th</sup> October 2023**

- 3.2.5 Of relevance to this report is the decisions made by Cabinet on 4<sup>th</sup> October 2023 (**See Appendix 4**), which included:

- Commence a public consultation exercise for the provision of Gypsy & Traveller pitches at Langley Close, Bradbury Farm and Oakgrove and
- To further explore the 19<sup>th</sup> of July 2023 Place Scrutiny Committees, request to support households to self-serve on existing sites, which subject to the necessary planning permissions, would reduce the number of pitches needed.

- 3.2.6 In addition to above and in the context of the comments made by the Place Scrutiny Committee on 19<sup>th</sup> July 2023, site evaluation surveys were commissioned to further inform site suitability. External specialists were appointed to undertake the following site surveys for each site:

- Noise assessment
- Land contamination assessment (not including Oakgrove on the advice of Environmental Health)
- Air quality assessment (not including Oakgrove on the advice of Environmental Health)
- Transport assessment
- Ecology assessment

- 3.2.7 Details of the chronology of the activity and decisions between the 26<sup>th</sup> of July 2023 to 4<sup>th</sup> October 2023 Cabinet are included in **Appendix 2.**

#### **Officer Findings Further to Cabinet 4<sup>th</sup> October 2023**

- 3.2.8 Further to the Cabinet meeting of the 4<sup>th</sup> of October 2023, the following has been actioned:

#### **Public Consultation**

- 3.2.9 Grasshopper, a specialist and independent community engagement agency were appointed to undertake the agreed public consultation on behalf of the Council. The purpose of the consultation was to implement a methodology that delivered a sound reflection of local views, and the aim was for the consultation to be open, transparent, inclusive and engaging.
- 3.2.10 The public consultation ran for six weeks from 9<sup>th</sup> November 2023 to December 2023. The consultation included three drop-in events, a feedback questionnaire and website

information. The level of participation and engagement was significant with over 400 individual responses being received from local residents and other stakeholders.

- 3.2.11 The detailed findings and analysis of feedback and views from the public consultation can be found in **Appendix 5**.

#### **Site Investigation Surveys**

- 3.2.12 As previously mentioned, specialist advisors were appointed to undertake Noise, Land Contamination (except for Oakgrove as recommended by Environmental Health), Air Quality (except for Oakgrove as recommended by Environmental Health), Transport and Ecology site. **See Appendix 6**.

- 3.2.13 Each of the site investigation surveys have been considered and reviewed by the Council's Environmental Health, Highways and Ecology Teams. Internal reports to complement the site investigation surveys have been received providing additional comments accordingly and where applicable, further recommendations have been made. **See Appendix 7**.

### **3.3 Pitch & Site Identification Outcomes**

#### **Supporting Households to Self-Serve to Meet Their Own Need**

- 3.3.1 The Local Planning Authority received a Planning application from a household to develop their privately owned land from a household that is part of the Gypsy and Traveller Assessment 2021 and the original need for 13 pitches. The Planning application for **four** pitches was considered by the Council's Planning Committee on 16<sup>th</sup> July 2024. The application for **four** pitches was approved, subject to an appropriate Assessment being agreed with Natural Resources Wales. Given this decision the overall pitch need for the Council to address the need identified in the GGTA reduces from **11 to 7**.

#### **Summary Overview of the Evidence for Withdrawing Langley Close – See Appendix 5, 6 & 7**

- 3.3.2 The Council has concluded that Langley Close is less suitable for development as a Gypsy and Traveller site, essentially based on the findings relating to Noise and Land Contamination. The main material evidence that has informed this conclusion is:

- **Noise Survey** – A high risk of noise impacting the northern part of the site and a medium risk of noise for the remainder was identified. Based on levels measured, interior noise levels would exceed recommended levels. Part of the site (NEC B designated) could potentially be developed, but mitigating measures would be necessary. The Southeast boundary of this area would adjoin existing homes.
- **Land Contamination** - Intrusive ground investigation was not considered necessary as the geoenvironmental risks were not considered to be sufficiently high. Localised 'Made Ground' might be present along the Southeastern boundary adjacent to existing homes, and it would be reasonable to exclude the Southeastern boundary next to properties from being landscaped or be available for growing produce.
- **Public Consultation** - Feedback received included issues and concern relating to noise, pollution and location, which the site surveys substantiated.
- **Site Evaluation Conclusions** – On the basis of findings, it is considered that Langley Close is less suitable for Gypsy & Traveller site development because:

- The location of the developable area, referred to as NEC B, (subject to mitigation measures) would have an impact on the the layout and size of the proposal which would constrain the developable area which would present design issues, which will be further compounded by the likely presence of 'made ground.'

**Summary Overview of the Evidence for Withdrawing Oakgrove Farm – See Appendices 5, 6 & 7**

3.3.3 The Council has concluded that Oakgrove Farm is less suitable for development as a Gypsy and Traveller site, as it has been assessed as having less advantages/benefits than Bradbury Farm, Crick in terms of its location. Based on the number of pitches required it is, therefore, proposed to withdraw Oakgrove Farm. The main material evidence that has informed this conclusion is:

- **Noise Survey** – A medium/high risk of noise impacting the southern part of the site closest to the B4245. 95m from the B4245 there is a medium risk of noise. However, if an earth bund or solid noise barrier were constructed along the southern edge of the site this may provide sufficient sound attenuation that the internal noise criteria recommended would be met within mobile homes on the northern part of the site.
- **Transport** – For the residential use proposed, considerations should include the lack of sustainable transport facilities surrounding the site, with no footway connections available on the B4245. The site is positioned in and as such has very little supply of complimentary facilities / amenities in close proximity. This could lead to the site being largely car-dominated in terms of trips, with little opportunity available for the uptake of active travel modes or use of sustainable transport. The Highway authority hasn't objected to the proposed use but consider location is not a sustainable transport location.
- **Air Quality, Land Contamination and Ecology Surveys** – Air Quality and Land Contamination surveys weren't required, and the Ecology Survey didn't identify any significant planning constraints that could not be addressed or mitigated against
- **Public Consultation** – Feedback received included issues and concerns related to traffic and road safety and the principle of its location.
- **Site Evaluation Conclusions** – On the basis of the findings, it is considered that whilst Oakgrove Farm has potential for development as a Gypsy and Traveller site, but is less suitable than Bradbury Farm, Crick and, therefore, on the basis of pitch need should be withdrawn from the process because:
  - The location is currently not conducive to Active Travel and is not considered to be a sustainable transport location. The lack infrastructure e.g. footways and local amenities is considered a constraint.

**Summary Overview of the Evidence for Bradbury Farm as the Preferred Option – See Appendices 5, 6 & 7**

3.3.4 The Council's site evaluation process has determined that Bradbury Farm is the preferred option for development as a Gypsy and Traveller site. The main material evidence that has informed this conclusion is:

- **Air Quality, Transport and Ecology Survey** – None of these surveys identified significant planning constraints that could not be addressed or mitigated against. For example, a new access would be required, and Active Travel links would be improved with the adjacent Strategic Development Site proposed through the emerging RLDP. Further Air Quality and Ecology Survey work would be necessary at a Planning application stage together with a Transport Statement/Technical Note and detailed access drawings to inform future consideration.
- **Noise Survey** - A medium/high risk in the Northwest of the site and low/medium in the Southeastern area were identified. Based on levels measured, interior noise levels would exceed recommended levels. Part of the site could potentially be developed, but mitigating measures would be necessary.
- **Land Contamination** - Intrusive ground investigations were not considered necessary. However, should development be agreed, if any unforeseen ground conditions were encountered any works must be stopped and risk assessed. Soil samples would be required prior to development based on the assumption that residents will come into contact with soil and may want to grow produce. The northern part of the site should be excluded due to the possibility of 'made ground.'
- **Public Consultation** - Feedback received included issues and concern relating to noise, pollution and location, which the site surveys substantiated.
- **Site Evaluation Conclusions** – On the basis of the findings, it is considered that Bradbury Farm, Crick is potentially suitable for development as a Gypsy and Traveller site because:
  - The location of the site will be sustainable due to being adjacent to the proposed Strategic Development site for the RLDP. The site affords a section of the land that has sufficient area capacity to be developed and in a location that has been assessed as having a low/medium risk of noise and avoids the likely presence of 'made ground' to the north of the site. There would be a need to mitigate against noise. To inform the required mitigation, indicative site design work will be required, and this will be considered as part of the RLDP and any future planning application. This design work has been commissioned.
  - Further survey work will be necessary to meet the requirements of the RLDP and to progress the proposal. This will be required as part of any potential planning application.

#### 4. **EQUALITY AND FUTURE GENERATIONS EVALUATION (INCLUDES SOCIAL JUSTICE, SAFEGUARDING AND CORPORATE PARENTING)**

- 4.1 Negative implications have been identified in respect of this proposal to put forward Bradbury Farm for inclusion in the Preferred Replacement Development Plan and the development of pitch provision. **See Appendix 8.** Consideration will be given to mitigating measures.

#### 5. **OPTIONS APPRAISAL AND RISK ASSESSMENT**

- 5.1 All Councils in Wales have a duty under Part 3, Housing (Wales) Act 2014 to meet unmet need for mobile home pitches where it is identified, there are therefore two options to consider in Table One below, Option One is the preferred option.

**Table One: Options Appraisal**

Option	Benefit	Risk
<p><b>Option 1:</b> The <u>recommended option</u> is that Cabinet gives approval to put forward Bradbury Farm as the preferred options for meeting the identified pitch need and development as Gypsy, Roma and Traveller sites.</p>	<ul style="list-style-type: none"> <li>• This contributes to the Council's legal responsibilities to meet identified Gypsy, Roma and Traveller pitch needs.</li> <li>• It is a Welsh Government requirement of the development of Replacement Local Development Plan includes that identified need for Gypsy, Roma and Traveller pitch need is met.</li> <li>• Timely progress is needed to meet the RLDP timetable.</li> </ul>	<ul style="list-style-type: none"> <li>• Based on meeting identified pitch need and assuming a maximum of 6 pitches are developed, this will mean 1 pitch out of the 13-pitch need won't be met. Alternatively, 7 pitches are developed which is slightly higher than the Council's initial intention.</li> <li>• It is possible there may be community objection to any proposed development of Council owned land for Gypsy and Traveller sites.</li> <li>• There will be future financial implications associated with continuing to evaluate and finalise suitability e.g. indicative design work.</li> <li>• There will be future financial implications associated with any final decisions relating to developing and managing a proposed site, although it is anticipated that Welsh Government capital grant will be available.</li> </ul>
<p><b>Option 2:</b> That Cabinet gives approval to put forward Bradbury Farm <b>and</b> Oakgrove as the preferred options for meeting the identified pitch need and development as Gypsy, Roma and Traveller sites.</p>	<ul style="list-style-type: none"> <li>• This will still contribute positively to the Council's legal responsibilities to meet identified Gypsy, Roma and Traveller pitch needs.</li> <li>• It is a Welsh Government requirement of the development of Replacement Local Development Plan includes that identified need for Gypsy, Roma</li> </ul>	<ul style="list-style-type: none"> <li>• It is possible there may be community objection to any proposed development of Council owned land for Gypsy and Traveller sites.</li> <li>• Subject to final decisions, this option will impact on the number of pitches the Council will be able to provide and it reduces the likelihood of the Council meeting the full remaining identified need (i.e., 11 pitches) for Monmouthshire.</li> </ul>

Option	Benefit	Risk
	<p>and Traveller pitch need is met.</p> <ul style="list-style-type: none"> <li>Timely progress is needed to meet the RLDP timetable</li> </ul>	<ul style="list-style-type: none"> <li>There will be future financial implications associated with any final decisions relating to developing and managing a proposed site, although it is anticipated that Welsh Government capital grant will be available.</li> </ul>
<p>Option 3 – To develop all three sites as Gypsy and Traveller sites</p>	<ul style="list-style-type: none"> <li>It is considered that this isn't necessary based on the residual and outstanding pitch need of 7.</li> </ul>	<ul style="list-style-type: none"> <li>This would be unnecessary development and not a good use of resources.</li> <li>Insufficient pitch need has been identified</li> </ul>
<p>Option 4 – To withdraw all the three sites for development as gypsy &amp; Traveller sites.</p>	<ul style="list-style-type: none"> <li>There are no benefits to this option.</li> </ul>	<ul style="list-style-type: none"> <li>The Council would not be meeting its legal duty to meet identified pitch needs for Monmouthshire.</li> <li>The Council would not be meeting the requirement of Welsh Government to reflect Gypsy and Traveller pitch requirement and provision in the RLDP.</li> </ul>

## 5.2 Proposed Next Steps

The proposed next steps in respect of both site identification **and** the Replacement Local Development Plan are:

- Include Bradbury Farm, Crick as a Gypsy & Traveller site in the Deposit RLDP
- Autumn 2024 – Council to consider consulting on Deposit RLDP
- Autumn 2024 – detailed public consultation with communities on the Deposit RLDP
- Late Spring 2025 – Deposit RLDP to Council following consultation for approval to submit to the Welsh Government for public examination by an independent inspector.
- Summer 2025 Examination by independent inspector of the RLDP
- Early 2026 – RLDP to Council for adoption.

Any future development on the site will then require a detailed planning application which would also include public consultation.

## 6. REASONS

- 6.1 The Council has a duty under Part 3, Housing (Wales) Act 2014 to address unmet need for mobile home pitches where identified. Using Council owned land is one option for meeting identified need.



## **7. FINANCIAL IMPLICATIONS**

- 7.1 The Council can meet its statutory duty through a number of options, including purchasing land or leasing land from another landowner. The Council has opted to focus (as per the current site identification process) firstly on determining whether any of the Council's land is suitable for pitch provision and making the best use of existing resources. This is to avoid any unnecessary capital expenditure acquiring additional land.
- 7.2 The Council has incurred £59,411 expenditure to date in respect of site identification work.
- 7.2 The estimated cost of appointing an architecture company to undertake some initial indicative design work, to inform on-going evaluation is approximately £15,000. This will be funded from the existing Strategic Housing budget.
- 7.4 Although not directly relating to this report, there will be capital and revenue cost implications relating to any possible future decision to develop pitch provision. As yet, the Council has **not** sought to identify and estimate site development costs until such time a decision has been by the Council that a site is considered suitable, which will be made after consultation. Costs will be determined at the stage of designing a site. These costs will need to be appraised and evaluated as part of the decision-making process. Such cost will vary depending on the land identified and other variables such as size and number of pitches. The Council will engage with Welsh Government in respect of possible capital grant availability. Also, nor has the Council sought to identify and estimate any running and management costs of a developed site. There will be a need to determine such estimated revenue costs and establish a budget accordingly. Revenue budget requirements will be identified at the point of preparing a detailed and fully designed proposal ahead of submitting a planning application.

## **8. CONSULTEES**

- 8.1 Cabinet; Senior Leadership Team; Communities & Place DMT; Housing Management Team; Travelling Ahead – Gypsy and Traveller Advocates; Principal Environmental Health Officer; Snr Landscape and Urban Officer; Biodiversity and Ecology Lead; Highways Development Manager and Head of Placemaking.
- 8.2 The Council has undertaken a public consultation exercise on Langley Close, Bradbury Farm and Oakgrove Farm. **See Appendix 5.**

## **9. BACKGROUND PAPERS:**

**Appendix 1** – Site Overviews

**Appendix 2** – Site Identification Process

**Appendix 3** – RAG document

**Appendix 4** – Minutes of Cabinet 4<sup>th</sup> October 2023

**Appendix 5** - Public Consultation Report

**Appendix 6** – Noise; Land Contamination; Air Quality; Transport & Highways Site Surveys

**Appendix 7** – Internal Reviews of Site Surveys by Environmental Health, Highways and Ecology Services.

**Appendix 8** – Equalities & Future Generations Assessment.

## **10. AUTHORS:**

Ian Bakewell – Housing & Communities Manager; Cath Fallon – Head of Rural Development, Housing and Partnerships

12. **CONTACT DETAILS:** [ianbakewell@monmouthshire.gov.uk](mailto:ianbakewell@monmouthshire.gov.uk)  
[Cathfallon@monmouthshire.gov.uk](mailto:Cathfallon@monmouthshire.gov.uk)

## Appendix 1

### Site Descriptions & Location Maps

#### Gypsy & Traveller Site Identification – MCC Land Evaluation

<b>MCC Land – Oakgrove Farm</b>	
<b>Site Size</b> – Approx 7976 m <sup>2</sup>	<b>Pitch Capacity</b> – sufficient to accommodate six pitches.
<b>General Description</b> <ul style="list-style-type: none"><li>• Rural</li><li>• Situated on B4245 approximately a mile from the edge of Caldicot.</li><li>• The land forms part of the Council's County Farms estate and is occupied via an agricultural tenancy. It is anticipated this tenancy would need to be amended should the site be supported for this use.</li><li>• Land currently used for agriculture.</li></ul>	
<b>Ward</b> – Portskewett	
<b>Photo's</b>   	



## Site Descriptions & Location Maps

### Gypsy & Traveller Site Identification – MCC Land Evaluation

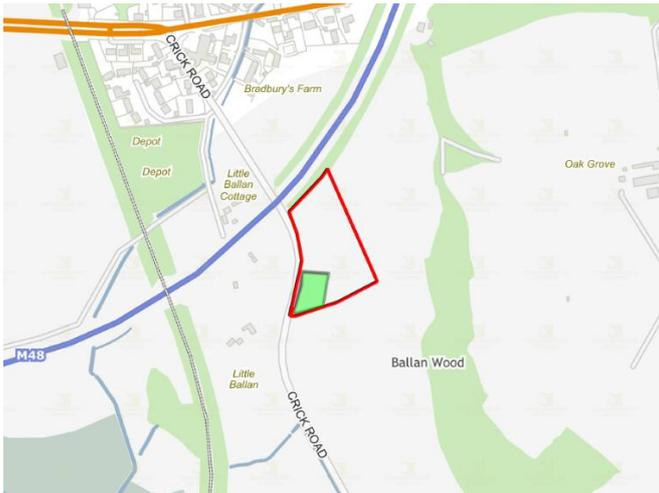
<b>MCC Land – Bradbury Farm, Crick</b>		
<b>Site Size</b> – Approx 18,022 m <sup>2</sup>	<b>Pitch Capacity</b> – sufficient to meet MCC's pitch needs*  It is recommended no more than 5 or 6 pitches	
<b>General Description</b> <ul style="list-style-type: none"><li>• Rural</li><li>• Situated directly off Crick Road</li><li>• M48 to the north elevation of the land</li><li>• Hedgerow and fencing to east, west and south elevation.</li></ul>		
<b>Ward – Portskewett</b>		
<b>Photo's</b>		
		
		



## Site Descriptions & Location Maps

### Gypsy & Traveller Site Identification – MCC Land Evaluation

<b>MCC Land – Langley Close, Magor</b>	
<b>Site Size</b> – Approx 23,431m <sup>2</sup>	<b>Pitch Capacity</b> – sufficient to meet MCC's pitch needs*  It is recommended no more than 5 or 6 pitches.
<b>General Description</b> <ul style="list-style-type: none"><li>• Urban</li><li>• Access off St Brides Road.</li><li>• The land forms part of the Council's County Farms estate and is occupied via a grazing license. It is anticipated this license would need to be terminated/amended should the site be supported for this use.</li><li>• Residential properties adjoining southern boundary. M4 to the north, open land to east and west.</li><li>• Tree belt around the site</li></ul>	
<b>Ward</b> – Magor West	
<b>Photo's</b>	
	





## Appendix 2

### Gypsy & Traveller Site Identification Process

June 2024

6<sup>th</sup> October 2018 – Note to Members of the former Adults Select Committee on proposal to establish Workshops.

October 2018 – Officer work commences on considering approach to identifying land for Gypsy & Traveller pitch provision, including MCC assets.

26<sup>th</sup> October 2018 – Members Workshop to acquire views of Members – Introduction to Legal Duty to meet Gypsy & Traveller pitch needs and update on housing requirement for the Gypsy & Traveller Accommodation Assessment 2020-25 and to 2033 of the Replacement LDP. [No slides produced].

29<sup>th</sup> March 2019 – Members Workshop to acquire views of Members on the proposed methodology for sifting MCC owned land. Focus was on Gypsy & Traveller site Planning Criteria.

4<sup>th</sup> June 2019 – Member visit through Adults Select Committee to Torfaen County Borough Council Gypsy & Traveller site, Shepherds Hill, Pontypool.

10<sup>th</sup> October 2019 – Email to former Adults Select Committee Members asking for comments on draft advert targeting Gypsy & Traveller community inviting to participate in Gypsy & Traveller Assessment.

27<sup>th</sup> November 2019 – All Members and Officers Awareness Training by Travelling Ahead, Gypsy & Traveller Advocate.

10<sup>th</sup> December 2020 – Report to Joint Select Committee: Adult and Economy & Development Selects – Scrutinise draft Gypsy & Traveller Assessment report and findings. ([Public Pack](#))[Agenda Document for Joint Select Committee, 10/12/2020 10:00 \(monmouthshire.gov.uk\)](#)

6<sup>th</sup> January 2021 – Report to Cabinet – Approve and adopt Gypsy & Traveller Accommodation Assessment report. ([Public Pack](#))[Agenda Document for Cabinet, 06/01/2021 14:00 \(monmouthshire.gov.uk\)](#)

March 2021 – **Stage 1** - Asset Review by Estates to start identifying land with potential for use as Gypsy & Traveller site(s)

21<sup>st</sup> September 2021 – Report to Adults Select – Scrutinise Site identification update. ([Public Pack](#))[Agenda Document for Adults Select Committee, 21/09/2021 10:00 \(monmouthshire.gov.uk\)](#)

September 2021 – Site Evaluation Commences

**Stage 1** – Completed Asset Review by Estates:

- Regard given to Welsh Government Site Design Guidance 2015
- Approximately 1500 council assets have been reviewed and considered
- Sites removed to date through Estates:

[Asset is a MCC property; Cemetery Land; Allocations in the existing adopted LDP; tree planting; Woodland; Covered by a ground lease; Council Car Park; Footpath/road]

**Stage 2** – Sites removed due to the following:

- **Site is less than 500sqm; Equipped Children’s Play Area; Playing Fields (Pitch); County Farm Holdings; Allocations in the existing adopted LDP/ RLDP promotion sites; Known unfavourable topography; C1 & C2 Flood Risk** – known sites in flood risk removed; **Sites with any uncertain inputs have been carried forward to the next stage for further assessment**
- Approximately 70 sites remained from 1500 sites

**Stage 3** – to assess for flood risk against and as per updated TAN 15. Land removed due to:

- **Sites wholly or mostly in Zones 2 & 3 of updated TAN15 flood risk maps (sea and river)**
  - Sites where boundary could potentially be amended to remove site out of flood risk kept on list
- **Surface water flood risk highlighted for further assessment**
- **Any constraints identified in Stage 1 & 2 if picked up at Stage 3.**

Approximately 50 sites from 1500 remaining.

**Also removed:**

- Brecon Beacons National Park Plan
- Within and adjacent to Conservation Areas and/or Historic Park & Garden
- Enclosed/surrounded by built environment privacy and amenity / placemaking
- National Ecological designations eg SSSI

20<sup>th</sup> July 2022 – Report to Adults Select – to include Gypsy & Site identification into the Committees work programme, participate in officer-led workshops and to scrutinise the proposed methodology for identifying and evaluating Council owned land for the purpose of providing a Gypsy & Traveller site. Also to invite Travelling Ahead - Gypsy, Roma and Traveller Advice & Advocacy Service to support the Council with the agreed approach. ([Public Pack](#))[Agenda Document for People Scrutiny Committee, 20/07/2022 10:00 \(monmouthshire.gov.uk\)](#)

8<sup>th</sup> August 2022 – Letter to Gypsy & Traveller community who contributed to Gypsy & Traveller Assessment, inviting to participate in site identification process.

29<sup>th</sup> September 2022 – All Member Workshop to acquire views of members – reminder of legal duties; consider ongoing methodology findings; planning implications; proposed approach including involving of Travelling Ahead.

October 2022

**Stage 4 – Land/Site Evaluation Criteria Developed**

- Site area
- Ability to provide utility infrastructure
- Flood Zone (updated TAN15 flood risk maps)

- Within or adjoining a settlement boundary
- Greenfield/brownfield
- Surround by built development
- Potential for expansion
- Within BBNP or AONB
- Within green wedge or potential greenbelt
- Within phosphates catchment area
- Adopted LDP DES2 allocation
- DES2 in review
- Within/adjacent to Conservation Area or Historic Parks & Garden
- Within Archeologically Sensitive Area
- Permanency
- Ecological Designation on whole or part of site (SSSI, SINC, SAC, RAMSAR, national/local nature reserve)
- Proximity to ecological designation
- Landscape Sensitivity (as recorded in the Landscape Sensitivity Study)
- Mineral safeguarding area
- Proximity to potential 'bad neighbours' e.g. dual carriageways, trunk roads, motorway, railway, industrial estates)
- Contamination (as recorded on Monmaps)
- School proximity
- Medical facility proximity
- Proximity to other amenities
- Public transport proximity and frequency
- Proximity to Historical Designation (inc Listed Buildings and Con Areas)
- Topography
- Access

October 2022 – **Stage 5** Further evaluation of 17 remaining site through officer RAG and visits. Reduced to 11 with parts of 2 sites at Dancing Hill being merged to form an amended Dancing Hill site, leaving 9 sites for internal consultation and discussion with the Gypsy & Traveller community.

1<sup>st</sup> November 2022 – Email to individual Members with a site in their ward in respect of forthcoming Members Workshop.

3<sup>rd</sup> November 2022 – All Member Workshop to acquire views – consider proposed 9 pieces of land should remain in the process for continued evaluation.

10<sup>th</sup> November 2023 – **Stage 5** – Continue evaluating 9 remaining sites. Internal services contacted requested to provide feedback on 9 sites.

30<sup>th</sup> January 2023 – All Member and officer Gypsy & Traveller Awareness Training by Travelling Ahead. See Appendix 3

31<sup>st</sup> January 2023 – Updated RAG following receipt of feedback from internal consultees. Officer Meeting to consider feedback on 9 sites.

13<sup>th</sup> June 2023 – Informal Cabinet – informally discuss next steps

23<sup>rd</sup> June 2023 – Email to individual Members with a site in their ward in respect of forthcoming Members Workshop

27<sup>th</sup> June 2023 – Email to all Members – background papers for 4<sup>th</sup> July 2023 Members Workshop

4<sup>th</sup> July 2023 – All Member Workshop to acquire views – proposal to consult on four locations, undertake further investigations in respect of one location and four to be removed from the process.

7<sup>th</sup> July 2023 – Environmental Health briefing on sites x 5 and Land Contamination, Noise and Air Quality Assessments.

14<sup>th</sup> July 2023 – All Member site visits x 9. Feedback received to further inform RAG and suitability.

19<sup>th</sup> July 2023 – Report to People Scrutiny – Proposal to consult on four sites and investigative work on a fifth site. ([Public Pack\)Agenda Document for People Scrutiny Committee, 19/07/2023 10:00 \(monmouthshire.gov.uk\)](#))

26<sup>th</sup> July 2023 – Report to Cabinet – Approve 4 sites for consultation and one for further investigative work. Decision made to defer consultation on the selection of potential sites for Gypsy and Traveller accommodation to allow more time for consideration – no sites have been confirmed for consultation at this stage.

Three sites removed from process as determined unsuitable.

28<sup>th</sup> July 2023 – preparations to commission land contamination, air and noise assessments for Magor with Undy sites to continue to assess their potential suitability and to inform future consultation.

August 2023

- Review of 17 site shortlist to a) ensure nothing was ruled out that shouldn't have been and b) ensure wording is consistent and robust.
- Review of 9 site shortlist to ensure information is consistent and robust
- Assessment of MCC RLDP candidate sites – there are 5 sites submitted for residential development, one for tourism, two for solar farms and one for a mix of employment and solar farm. All 9 will be assessed for suitability
- Public call for any sites closing 23<sup>rd</sup> August 2023.
- Potential review of all other (non-MCC) RLDP candidate sites (approx.250)
- Continue to seek to address need wherever possible on existing private sites, subject to the necessary permissions eg facilitate self-serving.

4<sup>th</sup> October 2023 – Cabinet – the meeting ratified the proposal made at Cabinet on 26<sup>th</sup> July 2023 to remove Manson Heights, Monmouth' Garrow Road, Mitchel Troy; Rocklea, Mitchel Troy; Dancing Hill West, Magor and to put forward two Council owned RLDP candidate sites, Bradbury Farm and Oakgrove.

The Cabinet also agreed to the commencement of a public consultation exercise for the potential to provision of up to 6 pitches each at Bradbury Farm, Crick; Oakgrove Farm, Portskewett and Langley Close, Magor, whilst also continuing to support households wanting to self-serve.

In addition to the Cabinet recommendations and in the context of the comments made by The Place Scrutiny Committee on 19<sup>th</sup> July 2023, it was considered appropriate to commission site evaluation surveys to further help inform site suitability. External Specialists were appointed to undertake the following site surveys for each site:

- Noise assessment

- Land contamination assessment (not including Oakgrove on the advice of Environmental Health)
- Air quality assessment (not including Oakgrove on the advice of Environmental Health)
- Transport assessment
- Ecology assessment

November to December 2023 – 6-week public consultation - co-ordinated on behalf of the Council by Grasshopper, communications agency to acquire feedback about The suitability of Langley Close, Magor; Bradbury Farm, Crick and Oakgrove, Portskewett.

May 2024 – officer consideration and analysis completed of Grasshopper public consultation and findings.

June 2024 – officer consideration and analysis of findings from completed and finalised site surveys together with internal comments and recommendations from Environmental Health, Highways and Ecology Teams.

## Appendix 3

### RAG Document

**Minutes of Cabinet 4<sup>th</sup> October 2024**

That Cabinet accept the recommendations as set out below:

Ratification of the proposal to remove the following sites from the site identification process as per the statement made to Cabinet on the 26th of July 2023 by the then Cabinet Member for Inclusive Communities:

- Manson Heights, Monmouth
- Garrow Road, Mitchel Troy
- Rocklea, Mitchel Troy.

Following further consideration of feedback from the Place Scrutiny Committee on the 19th of July 2023 and the wider Magor and Undy community, ratification of the proposal to remove Dancing Hill West, Magor from the list of potential sites, as per the reasons stated in paragraph 3.9.

Following a review of Council owned 'Candidate sites', to put forward two sites of up to 6 pitches each at the Caldicot East strategic site identified within the Replacement Local Development Plan Preferred Strategy.

The commencement of a public consultation exercise on the following Council owned sites (site summary profiles provided in Appendix 1), for the potential provision of up to six Gypsy, Roma and Traveller pitches each:

- Bradbury Farm, Crick, Caldicot
- Oak Grove Farm, Crick, Caldicot
- Langley Close, Magor.

Inclusion in the public consultation, any suitable sites brought forward through the public call for sites, that the owner is willing to sell or lease long term to the Council.

Further exploration of the 19th of July Place Scrutiny Committee's request to support households wishing to self-serve on existing sites which, subject to the necessary permissions, would reduce the number of new pitches needed.

To approve the attached FAQs (Appendix 2), an iterative document which will be displayed and regularly updated on the Council's website.











This page is intentionally left blank

Stage 1 - An appraisal of All MCC owned land and regard to WG Site Design Guide 2015. Approximately 1500 council assets have been reviewed and considered. Sites removed to date through Estates: Asset is a MCC property; Cemetery Land; Allocations in the existing adopted LDP; tree planting; Tree Planting Scheme; Woodland; Covered by a ground lease; Council Car Park; Footpath/road

Stage 2 – Sites removed due to the following: Site is less than 500sqm – desired pitch size is min 500sqm for public sites. [A pitch capable of accommodating an amenity block, mobile home, caravan and parking for two vehicles]; Equipped Children’s Play Area; Playing Fields (Pitch); County Farm Holdings; Allocations in the existing adopted LDP/ RLDP promotion sites; Known unfavourable topography; Woodland areas that were missed on Stage 1; C1 & C2 Flood Risk – known sites in flood risk removed; Sites with any uncertain inputs have been carried forward to the next stage for further assessment

Stage 3 – to assess flood risk as per updated TAN 15. Site removed due to: • Sites wholly or mostly in Zones 2 & 3 of updated TAN15 maps (sea and river) • Sites where boundary could potentially be amended to remove site out of flood risk kept on list • Surface water flood risk highlighted for further assessment • Any constraints identified in Stage 1 & 2 if picked up at Stage Approximately 50 sites from 1500 remaining Also removed: • Brecon Beacons National Park Plan • Within and adjacent to Conservation Areas and/or Historic Park & Garden • Enclosed/surrounded by built environment privacy and amenity / placemaking • Within national Ecological designations eg SSSI

Stage 4 – Post Workshop 2. Site Area Ecological Designation on whole or part of site (SSSI, SINC, SAC, RAMSAR, national/local nature reserve) ,Ability to provide utility infrastructure, Flood Zone (Updated TAN 15 Flood Maps), Proximity to ecological designation, Within or adjoining a Settlement Boundary, Landscape Sensitivity (as recorded in the Landscape Sensitivity Study), Greenfield/Brownfield, Mineral Safeguarding Area, Surrounded by Built Development, Proximity to potential 'bad neighbours' (e.g. dual carriageways, trunk roads, motorway, railway, industrial estates), Potential for expansion, Within BBNP or AONB, Contamination (as recorded on Monmaps), Within Green Wedge or potential Green Belt, School Proximity, Within Phosphates Catchment Area, Medical Facility Proximity, Adopted LDP DES2, Allocation Proximity to other Amenities, DES2 in Review, Public transport proximity and frequency, Within/adjacent to Conservation Area or Historic Parks & Garden, Proximity to Historical Designation (inc Listed Buildings and Con Areas), Within Area of Archeological Sensitivity, Topography, Permanency, Access

Stage 5 - RAG rating against criteria above following officer site visits, input from internal consultees, feedback from Gypsy and Traveller community and Travelling Ahead

Business Unit Name	Postal Address	Suitability / Availability	Size	Highway Access	Access to facilities	Constraints	Conclusion	Alternative Name
The Barn/Gingers Antiques' - Unit 1 Fairfield	The Barn - Unit 1 Fairfield, Park Street, Abergavenny, Monmouthshire, NP7 5YD	A1 Shops, Antiques & Collectables	N/A	N/A	N/A	N/A	Property - therefore unsuitable	
31a Hillcrest Road	Hillcrest Road, 31a, Abergavenny, Monmouthshire, NP7 6BN	A1 Shops, Butcher	N/A	N/A	N/A	N/A	Property - therefore unsuitable	
50a Bulwark Road	Bulwark Road, 50a, Chepstow, Monmouthshire, NP16 5JW	A1 Shops, Butcher	N/A	N/A	N/A	N/A	Property - therefore unsuitable	
52a Bulwark Road	Bulwark Road, 52a, Chepstow, Monmouthshire, NP16 5JW	A1 Shops, Card Retailer	N/A	N/A	N/A	N/A	Property - therefore unsuitable	
Hanbury House, Unit 4 Cobblers	Hanbury House, Unit 4 Cobblers, Welsh Street, Chepstow, NP16 5LL	A1 Shops, Cobblers	N/A	N/A	N/A	N/A	Property - therefore unsuitable	
29a Hillcrest Road - Ace Centre	Hillcrest Road, 29a, Abergavenny, Monmouthshire, NP7 6BN	A1 Shops, Communities First	N/A	N/A	N/A	N/A	Property - therefore unsuitable	
82 Woodland View	Woodland View, 82, Monmouth, Monmouthshire, NP25 3LD	A1 Shops, Community	N/A	N/A	N/A	N/A	Property - therefore unsuitable	
109 Oakley Way	Oakley Way, 109, Caldicot, Monmouthshire, NP26 4EB	A1 Shops, Convenience Store	N/A	N/A	N/A	N/A	Property - therefore unsuitable	
111 (& 113) Oakley Way	Oakley Way, 111 (& 113), Caldicot, Monmouthshire, NP26 4EB	A1 Shops, Convenience Store	N/A	N/A	N/A	N/A	Property - therefore unsuitable	
113 (& 111) Oakley Way	Oakley Way, 113 (& 111), Caldicot, Monmouthshire, NP26 4EB	A1 Shops, Convenience Store	N/A	N/A	N/A	N/A	Property - therefore unsuitable	
25a Hillcrest Road	Hillcrest Road, 25a, Abergavenny, Monmouthshire, NP7 6BN	A1 Shops, Convenience Store	N/A	N/A	N/A	N/A	Property - therefore unsuitable	
27a Hillcrest Road	Hillcrest Road, 27a, Abergavenny, Monmouthshire, NP7 6BN	A1 Shops, Convenience Store	N/A	N/A	N/A	N/A	Property - therefore unsuitable	
Unit 1 Hanbury House	Hanbury House, Welsh Street, Chepstow, Monmouthshire, NP16 5LL	A1 Shops, Electrical Repair and Sales	N/A	N/A	N/A	N/A	Property - therefore unsuitable	
107 Oakley Way	Oakley Way, 107, Caldicot, Monmouthshire, NP26 4EB	A1 Shops, Hairdressers	N/A	N/A	N/A	N/A	Property - therefore unsuitable	
15 St Thomas Square	St Thomas Square, 15, Monmouth, Monmouthshire, NP25 5AA	A1 Shops, Hairdressers	N/A	N/A	N/A	N/A	Property - therefore unsuitable	
36 Highfield	Highfield, 36, Goytre, Abergavenny, Monmouthshire, NP4 0BH	A1 Shops, Hairdressers	N/A	N/A	N/A	N/A	Property - therefore unsuitable	
56a Bulwark Road	Bulwark Road, 56a, Chepstow, Monmouthshire, NP16 5JW	A1 Shops, Hairdressers	N/A	N/A	N/A	N/A	Property - therefore unsuitable	
The Kiosk, Market Hall, Monmouth	The Kiosk, Market Hall, Monmouth, Priory Street, Monmouth, Monmouthshire, NP25 5DD	A1 Shops, Hairdressers	N/A	N/A	N/A	N/A	Property - therefore unsuitable	
60a Bulwark Road	Bulwark Road, 60a, Chepstow, Monmouthshire, NP16 5JW	A1 Shops, Mencep	N/A	N/A	N/A	N/A	Property - therefore unsuitable	
The Trading Post	The Trading Post, The Bryn, Abergavenny, Monmouthshire, NP7 9AL	A1 Shops, Post Office	N/A	N/A	N/A	N/A	Property - therefore unsuitable	
Asda Woodstock Way	Asda Woodstock Way, Woodstock Way, Caldicot, Monmouthshire, NP26 5XA	A1 Shops, Retail	N/A	N/A	N/A	N/A	Property - therefore unsuitable	
The Snack Bar Abergavenny Bus Stop	The Snack Bar Abergavenny Bus Stop, The Bus Station, Abergavenny, Monmouthshire, NP7 6BN	A1 Shops, Snack Bar	N/A	N/A	N/A	N/A	Property - therefore unsuitable	
Full House Takeaway, Market Hall	Golden City Restaurant, Market Hall, Priory Street, Monmouth, Monmouthshire, NP25 5DD	A1 Shops, Takeaway	N/A	N/A	N/A	N/A	Property - therefore unsuitable	
Market Hall Cafe	Market Hall Cafe, Cross Street, Abergavenny, Monmouthshire, NP7 5HD	A3 Restaurants & Cafes, Cafe	N/A	N/A	N/A	N/A	Property - therefore unsuitable	
The Kiosk, Brewery Yard	The Kiosk, Brewery Yard, Brewery Yard, Abergavenny, Monmouthshire, NP7 5SD	A3 Restaurants & Cafes, Cafe	N/A	N/A	N/A	N/A	Property - therefore unsuitable	
1 (& 2) The Albion	The Albion, 1 (& 2), Cinderhill Street, Monmouth, Monmouthshire, NP25 5EZ	A3 Restaurants & Cafes, Fish & Chips	N/A	N/A	N/A	N/A	Property - therefore unsuitable	
2 (& 1) The Albion	The Albion, 2 (& 1), Cinderhill Street, Monmouth, Monmouthshire, NP25 5EZ	A3 Restaurants & Cafes, Fish & Chips	N/A	N/A	N/A	N/A	Property - therefore unsuitable	
Newport Leisure Park	Newport Leisure Park, Seven Stiles, Newport, Newport, NP19 4QQ	A3 Restaurants & Cafes and D2 Assembl	N/A	N/A	N/A	N/A	Property - therefore unsuitable	
1.85 acres at Dancing Hill, Undy	1.85 Caled Llawr, Dancing Hill, Undy, CALDICOT, NP26 3BY	Agricultural, Bare Land	1.85 acres	Via Dancing Hill	Adjacent to settlement	Close proximity to residential	Too small	
10/11/12/Pt13/34/9 Leechpool	Leechpool 10/11/12/Pt13/34/9, Rear of 9 Leechpool Holdings, Crick, Caldicot, Monmouthshire, NP26 5UJ	Agricultural, Bare Land	34.5 acres	B4245	Limited		Core Estate	LPL12
12 acres of land South of Trelleck	12 acres of South of Trelleck, Trelleck, Monmouth, Monmouthshire, NP25 4PF	Agricultural, Bare Land	12 acres	B4293		Outside development bounda	Outside development boundary	
14/Pt8 Llanfair Discoed	Llanfair Discoed 14/Pt8, Bentley Green, Crick, Caldicot, Monmouthshire, NP26 5UJ	Agricultural, Bare Land	???	???			Core Estate	LFD148
16 Llanfair Discoed	Llanfair Discoed 16, Westwood Farm, Caerwent, Caldicot, Monmouthshire, NP26 5UJ	Agricultural, Bare Land	13.39				Core Estate	LFD16
2A/2B Caldicot	Caldicot 2A/2B, Slough Farm, Caerwent, Caldicot, Monmouthshire, NP26 5NW	Agricultural, Bare Land	53 acres			Flooding issues	RLDP Promoted Site.	CAL2A2B
3 Llanfaches (MON CC)	Llanfaches 3 (MON CC), Colomendy, Llanfair Discoed, Chepstow, Monmouthshire, NP16 5JW	Agricultural, Bare Land	N/A	N/A	N/A	N/A	Unsuitable	LFC3
42 Leechpool	Leechpool 42, Lower Leechpool Farm, Portskewett, Caldicot, Monmouthshire, NP26 5UJ	Agricultural, Bare Land	37.7 acres				Core Estate	Leechpool 42
5 Llanfair Discoed	Llanfair Discoed 5, Llanfair Farm, Llanfair Discoed, Chepstow, Monmouthshire, NP16 5JW	Agricultural, Bare Land	14 acres				Core Estate	LFD5
7.27 acres at Dancing Hill, Undy	7.27 , Magor, CALDICOT	Agricultural, Bare Land	7.27 acres			Close proximity to M4		
8/9/4 Undy	Undy 8/9/4, Oaklands Farm, Llanfair Discoed, Chepstow, Monmouthshire, NP16 6JW	Agricultural, Bare Land	58.5 acres			Required for M4 Widening		UND894 Undy 8/9/4
Caerwent 10	Caerwent 10, Slough Farm, Caerwent, Caldicot, Monmouthshire, NP26 5NW	Agricultural, Bare Land	11 acres			Core Estate	RLDP Promoted Site.	CAE10
Caerwent 3A	Caerwent 3A, Slough Farm, Caerwent, Caldicot, Monmouthshire, NP26 5NW	Agricultural, Bare Land	11.3 acres			Core Estate	Core Estate	CAE3A
Crick 2 3B/9A Caerwent	Crick 2 Caerwent 3B/9A, Church Farm, Newchurch, Chepstow, Monmouthshire, NP16 5JW	Agricultural, Bare Land	64.8 acres			Flooding issues	Core Estate	CRK2CAE39
Main Road, Land South Side	Main Road, Land South Side, Portskewett, Caldicot, Monmouthshire, NP25 5SG	Agricultural, Bare Land	???	???			Too small	Smithy
OS 4594 at Ifton Hill	OS 4594 at Ifton Hill, Ifton Hill, Caldicot, NP26 5TU	Agricultural, Bare Land	10.77 acres				Core Estate	
OS 5223 at Ty Mawr	OS 5223 at Ty Mawr, Gilwern, Abergavenny, Monmouthshire	Agricultural, Bare Land	8.4 acres				Core Estate	
Pt10/13 Llanfair Discoed	Llanfair Discoed Pt10/13, Lower House Farm, Kemys Commander, Usk, Monmouthshire, NP23 5JW	Agricultural, Bare Land	33.3 acres				Core Estate	LFD1013
Pt8 Portskewett	Portskewett Pt8, 14, Station Road, Portskewett, Caldicot, Monmouthshire, NP26 5UJ	Agricultural, Bare Land	????			Too small		PSK8
Ty Mawr School Farm	Ty Mawr School Farm, Gilwern, Abergavenny, Monmouthshire, NP7 0EB	Agricultural, Bare Land	29.6 acres	Ty Mawr Road			BBNP	
Vineyard Wood	Vineyard Wood, Windmill Farm, Llanfaches, Caldicot, Monmouthshire, NP26 3AY	Agricultural, Bare Land	N/A	N/A	N/A	N/A	Unsuitable - drainage SPZ no m	Llanfair Discoed 18
23 Leechpool	23 Leechpool, Portskewett, Caldicot, Monmouthshire, NP26 5UB	Agricultural, Cottage	N/A	N/A	N/A	N/A	Property - therefore unsuitable	Leechpool 23H
28H Leechpool	Leechpool 28H, 28, Leechpool, Portskewett, Caldicot, Monmouthshire, NP26 5UA	Agricultural, Cottage	N/A	N/A	N/A	N/A	Property - therefore unsuitable	XCT10 28 Leechpool
30 Leechpool	30 Leechpool, Portskewett, Caldicot, Monmouthshire, NP26 5UA	Agricultural, Cottage	N/A	N/A	N/A	N/A	Property - therefore unsuitable	Leechpool 30H/Pt 43
3H Leechpool	Leechpool 3H, 3, Leechpool, Portskewett, Caldicot, Monmouthshire, NP26 5UU	Agricultural, Cottage	N/A	N/A	N/A	N/A	Property - therefore unsuitable	XCT05 3 Leechpool 3H
5 Leechpool	5 Leechpool, Portskewett, Caldicot, Monmouthshire, NP26 5UU	Agricultural, Cottage	N/A	N/A	N/A	N/A	Property - therefore unsuitable	LPL5 Leechpool 5H
6 Leechpool	6 6, Leechpool, Portskewett, Caldicot, Monmouthshire, NP26 5UU	Agricultural, Cottage	N/A	N/A	N/A	N/A	Property - therefore unsuitable	XCT06 Leechpool 6H
Church View	Church View, Church View, Trelech, Monmouth, Monmouthshire, NP25 4PJ	Agricultural, Cottage	N/A	N/A	N/A	N/A	Property - therefore unsuitable	XCT01
Hill Farm, Crick	Hill Farm, Crick, Hill Farm, Crick, Caldicot, Monmouthshire, NP26 5UT	Agricultural, Cottage	N/A	N/A	N/A	N/A	Property - therefore unsuitable	St Pierre 10H
3 Brooks Farm	3 Brooks Farm, Raglan, Usk, Monmouthshire, NP15 2HX	Agricultural, Dairy	1112 acres	Chepstow Road		RLDP Promotion	Councill Farm. Part of Core Est	Brooks Farm 3
4 Hayesgate Lane	4 Hayesgate Lane, Mathern, Chepstow, Monmouthshire, NP16 6LJ	Agricultural, Dairy	94 acres				Councill Farm. Part of Core Est	STP3 St Pierre 3
4 Llanddewi Court	4 Llanddewi Court, Llanddewi Skirrid, Abergavenny, Monmouthshire, NP7 8AL	Agricultural, Dairy	103 acres				Council Farm. Core Estate	Llanddewi Skirrid 4
5 Llanddewi Court	5 Llanddewi Court, Llanddewi Skirrid, Abergavenny, Monmouthshire, NP7 8AL	Agricultural, Dairy	137 acres				Council Farm. Core Estate	Llanddewi Skirrid 5
Greenmeadow Farm	Greenmeadow Farm, Greenmeadow Fm, Hayesgate, Mathern, Chepstow, Monmouthshire, NP16 6LJ	Agricultural, Dairy	89.9 acres				Councill Farm. Part of Core Est	St Pierre Pt30/Pt31
Ifton Hill Farm	Ifton Hill Farm, Ifton Hill Farm, Portskewett, Caldicot, Monmouthshire, NP26 5TT	Agricultural, Dairy	137 acres				Councill Farm. Part of Core Est	Ifton Hill 3/Pt4 Leechpool 19/20
Lower House Farm	Lower House Farm, Lower House Farm, Llanfair Discoed, Chepstow, Monmouthshire, NP16 5JW	Agricultural, Dairy	117 acres				Council Farm. Core Estate	Llanfair Discoed 1/6/12
Lower Leechpool Farm	Lower Leechpool Farm, Lower Leechpool Farm, Portskewett, Caldicot, Monmouthshire, NP26 5UJ	Agricultural, Dairy	80.1 acres				Council Farm. Core Estate	Leechpool 25
Old Llanishen Farm	Old Llanishen Farm, Old Llanishen Farm, Llangovan, Monmouth, Monmouthshire, NP23 5JW	Agricultural, Dairy	88 acres				Council Farm. Core Estate	Llanishen 3/4
Penarth Farm	Penarth Farm, Penarth Farm, Llanishen, Monmouth, Monmouthshire, NP16 6QH	Agricultural, Dairy	69.9 acres				Councill Farm. Part of Core Est	Llanishen 1
Rodge Farm	Rodge Farm, Rodge Farm, Caerwent, Caldicot, Monmouthshire, NP26 5PB	Agricultural, Dairy	164.5 acres				Councill Farm. Part of Core Est	Great House10/11
Slough Farm	Slough Farm, Slough Farm, Caerwent, Caldicot, Monmouthshire, NP26 5NW	Agricultural, Dairy	57.2 acres				Councill Farm. Part of Core Est	Caerwent 7/11
3 Llanddewi Court	3 Llanddewi Court, Llanddewi Skirrid, Abergavenny, Monmouthshire, NP7 8AL	Agricultural, Equestrian Training School	37.6 acres				Council Farm. Core Estate	Llanddewi Skirrid 3
0.81 acre at Dancing Hill	0.81 , Undy, Magor, Monmouthshire	Agricultural, Grazing	0.81 acres			Too Small	Grazing Land. Too small	



Car Park-Chepstow Castle	Car Park-Chepstow Castle, Guy Meadow, Chepstow, Monmouthshire	Council Car Park.	N/A	N/A	N/A	N/A	Unsuitable	Castle Dell
Car Park-Chippenham	Car Park-Chippenham, Monmouth, Monmouthshire	Council Car Park.	N/A	N/A	N/A	N/A	Unsuitable	
Car Park-Cinderhill Street	Car Park-Cinderhill Street, Monmouth, Monmouthshire	Council Car Park.	N/A	N/A	N/A	N/A	Unsuitable	
Car Park-Cornwall House	Car Park-Cornwall House, Monmouth, Monmouthshire	Council Car Park.	N/A	N/A	N/A	N/A	Unsuitable	
Car Park-Drill Hall	Car Park-Drill Hall, Lower Church Street, Chepstow, Monmouthshire, NP16 5HJ	Council Car Park.	N/A	N/A	N/A	N/A	Unsuitable	
Car Park-Fairfield	Car Park-Fairfield, Abergavenny, Monmouthshire, NP7 5SG	Council Car Park.	N/A	N/A	N/A	N/A	Unsuitable	
Car Park-Glendower Street	Car Park-Glendower Street, Monmouth, Monmouthshire	Council Car Park.	N/A	N/A	N/A	N/A	Unsuitable	
Car Park-Goytre	Car Park-Goytre, Parc y Brain Lane, Goetre, Abergavenny, Monmouthshire	Council Car Park.	N/A	N/A	N/A	N/A	Unsuitable	
Car Park-Jubilee Way	Car Park-Jubilee Way, Caldicot, Monmouthshire, NP26 4BG	Council Car Park.	N/A	N/A	N/A	N/A	Unsuitable	
Car Park-Llanvapley	Car Park-Llanvapley, Near Mabley Close, Abergavenny, Monmouthshire	Council Car Park.	N/A	N/A	N/A	N/A	Unsuitable	
Car Park-Magor Square	Car Park-Magor Square, Magor, Monmouthshire, NP26 3HY	Council Car Park.	N/A	N/A	N/A	N/A	Unsuitable	
Car Park-Main Road, Gilwern	Car Park-Main Road, Gilwern, Gilwern, Abergavenny, Monmouthshire, NP7 0AS	Council Car Park.	N/A	N/A	N/A	N/A	Unsuitable	
Car Park-Maryport Street (South)	Car Park-Maryport Street (South), Usk, Monmouthshire, NP15 1AD	Council Car Park.	N/A	N/A	N/A	N/A	Unsuitable	
Car Park-Maryport Street (North)	Car Park-Maryport Street (North), Usk, Monmouthshire, NP15 1AB	Council Car Park.	N/A	N/A	N/A	N/A	Unsuitable	
Car Park-Monnow Bridge, Monmouth	Car Park-Monnow Bridge, Monmouth, Monmouthshire	Council Car Park.	N/A	N/A	N/A	N/A	Unsuitable	Cattle Market Car Park
Car Park-Monnow Street	Car Park-Monnow Street, Monmouth, Monmouthshire	Council Car Park.	N/A	N/A	N/A	N/A	Unsuitable	
Car Park-Nelson Museum & Local History Centre	Car Park-Nelson Museum & Local History Centre, Off Castle Hill, Monmouth, Monmouthshire	Council Car Park.	N/A	N/A	N/A	N/A	Unsuitable	
Car Park-Nelson Street	Car Park-Nelson Street, Chepstow, Monmouthshire, NP16 5EX	Council Car Park.	N/A	N/A	N/A	N/A	Unsuitable	
Car Park-Rowing Club	Car Park-Rowing Club, Monmouth, Monmouthshire	Council Car Park.	N/A	N/A	N/A	N/A	Unsuitable	The Boat House Car Park
Car Park-Severn Bridge Social Club	Car Park-Severn Bridge Social Club, Bulwark Road, Chepstow, Monmouthshire	Council Car Park.	N/A	N/A	N/A	N/A	Unsuitable	
Car Park-Station Road	Car Park-Station Road, Chepstow, Monmouthshire, NP16 5PB	Council Car Park.	N/A	N/A	N/A	N/A	Unsuitable	
Car Park-Sycamore Terrace	Car Park-Sycamore Terrace, Magor, Monmouthshire, NP26 3EG	Council Car Park.	N/A	N/A	N/A	N/A	Unsuitable	Brassknocker Street Car Park
Car Park-Tiverton Place	Car Park-Tiverton Place, Abergavenny, Monmouthshire, NP7 5PN	Council Car Park.	N/A	N/A	N/A	N/A	Unsuitable	
Car Park-Town Hall	Car Park-Town Hall, Abergavenny, Monmouthshire, NP7 5HD	Council Car Park.	N/A	N/A	N/A	N/A	Unsuitable	
Car Park-Trinity Terrace	Car Park-Trinity Terrace, Abergavenny, Monmouthshire, NP7 5EA	Council Car Park.	N/A	N/A	N/A	N/A	Unsuitable	
Car Park-Tudor Street	Car Park-Tudor Street, Abergavenny, Monmouthshire, NP7 5DL	Council Car Park.	N/A	N/A	N/A	N/A	Unsuitable	
Car Park-Twyn Square	Car Park-Twyn Square, Usk, Monmouthshire, NP15 1BJ	Council Car Park.	N/A	N/A	N/A	N/A	Unsuitable	
Car Park-Welsh Street	Car Park-Welsh Street, Chepstow, Monmouthshire, NP16 5EL	Council Car Park.	N/A	N/A	N/A	N/A	Unsuitable	Formerly Bank Street
Car Park-Withy Close	Car Park-Withy Close, Magor, Monmouthshire, NP26 3LB	Council Car Park.	N/A	N/A	N/A	N/A	Unsuitable	
Car Park-Woodstock Way	Car Park-Woodstock Way, Caldicot, Monmouthshire, NP26 5DB	Council Car Park.	N/A	N/A	N/A	N/A	Unsuitable	
Gilwern Wharf Picnic Site & Car Park	Gilwern Wharf Picnic Site & Car Park, Off Church Road, Gilwern, Abergavenny, Monmouthshire	Council Car Park.	N/A	N/A	N/A	N/A	Unsuitable	
Hillcrest Road shops, Forecourt	Hillcrest Road shops, Forecourt, Abergavenny, Monmouthshire, NP7 6BN	Council Car Park.	N/A	N/A	N/A	N/A	Unsuitable	
Hilston Park Outdoor Centre	Hilston Park Outdoor Centre, Hilston Park, Newcastle, Monmouth, Monmouthshire	Declared surplus and under offer	N/A	N/A	N/A	N/A	Unsuitable	
New Cemetery Lodge Llanfoist	New Cemetery Lodge Llanfoist, Llanfoist, Abergavenny, Monmouthshire, NP7 9LF	Declared surplus and under offer	N/A	N/A	N/A	N/A	Unsuitable	
6 Greenfield, Footpath adjacent	Greenfield, Footpath adjacent to 6, Caldicot, Monmouthshire	Footpath	N/A	N/A	N/A	N/A	Unsuitable	
Burnt Barn Road, Highway	Burnt Barn Road, Highway, Chepstow, Monmouthshire	Footpath	N/A	N/A	N/A	N/A	Unsuitable	
Chepstow Racecourse, Underpass at	Chepstow Racecourse, Underpass at, St Arvans, Chepstow, Monmouthshire	Footpath	N/A	N/A	N/A	N/A	Unsuitable	
Dan y Deri, Footpaths at	Dan y Deri, Footpaths at, Abergavenny, Monmouthshire, NP7 6PH	Footpath	N/A	N/A	N/A	N/A	Unsuitable	
Footpath Coed Glas Site NE Corner	Footpath Coed Glas Site NE Corner, Firs Road, Abergavenny, Monmouthshire	Footpath	N/A	N/A	N/A	N/A	Unsuitable	
Footpath Link to Brynglas	Footpath Link to Brynglas, Crickhowell Road, Gilwern, Abergavenny, Monmouthshire	Footpath	N/A	N/A	N/A	N/A	Unsuitable	Footpath adjacent to Cathwin
Poplars Road, Land adjacent (200sqm)	Poplars Road, Land adjacent (200sqm), Poplars Road, Abergavenny, Monmouthshire	Footpath	N/A	N/A	N/A	N/A	Unsuitable	
Sewerage Works, Footpath at	Sewerage Works, Footpath at, Glanbaiden, Abergavenny, Monmouthshire	Footpath	N/A	N/A	N/A	N/A	Unsuitable	
St Ewens Road, Footpath near	St Ewens Road, Footpath near, Chepstow, Monmouthshire	Footpath	N/A	N/A	N/A	N/A	Unsuitable	
The Avenue, Highway Footpath at	The Avenue, Highway Footpath at, Govilon, Abergavenny, Monmouthshire, NP7 5	Footpath	N/A	N/A	N/A	N/A	Unsuitable	
Underhill Crescent, Footpath adjacent to 152	Underhill Crescent, Footpath adjacent to 152, Abergavenny, Monmouthshire	Footpath	N/A	N/A	N/A	N/A	Unsuitable	
Underhill Crescent, Footpath adjacent to 80	Underhill Crescent, Footpath adjacent to 80, Abergavenny, Monmouthshire	Footpath	N/A	N/A	N/A	N/A	Unsuitable	
War Memorial, Highway fronting	War Memorial, Highway fronting, Mathern, Chepstow, Monmouthshire	Footpath	N/A	N/A	N/A	N/A	Unsuitable	
Pen y Clawdd Former Refuse Tip	Llanvihangel Crucorney Former Refuse Tip, Pen y Clawdd, Raglan, Monmouthshire	Former refuse site.	0.97 acres	Restrict access via country lane			Topography	
Portskewett Former Refuse Tip	Portskewett Former Refuse Tip, Caldicot, Monmouthshire, NP26 5SA	Former refuse site.	4.1 acres	No access			Access	
31-33 Cinderhill Street	Cinderhill Street 31-33, Monmouth, Monmouthshire, NP25 5EY	Ground lease & property - therefore unsuitable	N/A	N/A	N/A	N/A	Unsuitable	Cinderhill Hostel
Housing Estate - Holmfield Drive	Housing Estate - Holmfield Drive, Llandogo, Monmouth, Monmouthshire	Ground lease & property - therefore unsuitable	N/A	N/A	N/A	N/A	Unsuitable	
Housing Estate - Langley Close	Housing Estate - Langley Close, Undy, Magor, Monmouthshire	Ground lease & property - therefore unsuitable	N/A	N/A	N/A	N/A	Unsuitable	
Housing Estate - Mill Common	Housing Estate - Mill Common, Undy, Magor, Monmouthshire	Ground lease & property - therefore unsuitable	N/A	N/A	N/A	N/A	Unsuitable	
Housing Estate - Millfield Park	Housing Estate - Millfield Park, Undy, Magor, Monmouthshire	Ground lease & property - therefore unsuitable	N/A	N/A	N/A	N/A	Unsuitable	
Housing Estate - Netherwent View	Housing Estate - Netherwent View, Undy, Magor, Monmouthshire	Ground lease & property - therefore unsuitable	N/A	N/A	N/A	N/A	Unsuitable	
Housing Estate - The Briars	Housing Estate - The Briars, Undy, Magor, Monmouthshire	Ground lease & property - therefore unsuitable	N/A	N/A	N/A	N/A	Unsuitable	
Housing Estate - The Plantation	Housing Estate - The Plantation, Undy, Magor, Monmouthshire	Ground lease & property - therefore unsuitable	N/A	N/A	N/A	N/A	Unsuitable	
Housing Estate - The Willows	Housing Estate - The Willows, Undy, Magor, Monmouthshire	Ground lease & property - therefore unsuitable	N/A	N/A	N/A	N/A	Unsuitable	
Housing Estate - Wheatsheaf Court	Housing Estate - Wheatsheaf Court, Undy, Magor, Monmouthshire	Ground lease & property - therefore unsuitable	N/A	N/A	N/A	N/A	Unsuitable	
Housing Estate - Withey Close	Housing Estate - Withey Close, Undy, Magor, Monmouthshire	Ground lease & property - therefore unsuitable	N/A	N/A	N/A	N/A	Unsuitable	
Cwm Clydach, Highway land at	Cwm Clydach, Highway land at, Heads of the Valley Road, Clydach, Abergavenny, Monmouthshire	Highway verge					Highway Land	
Cwm yr Hafod, Highway land at	Cwm yr Hafod, Highway land at, Main Road, Clydach, Abergavenny, Monmouthshire	Highway verge					Highway Land	Opposite The Unicorn
Beech Road Playground	Beech Road Playground, Caldicot, Monmouthshire, NP26 4DY	Land					Too small	
Belgrave Road Recreation Ground	Belgrave Road Recreation Ground, Abergavenny, Monmouthshire, NP7 7AD	Land	5.1 acres				Floods	
Blackrock Picnic Site & Car Park	Blackrock Picnic Site & Car Park, Black Rock Road, Sudbrook, Caldicot, Monmouthshire	Land	2.4 acres					
Blenheim Avenue Play area	Blenheim Avenue Play area, Magor, Caldicot, Monmouthshire, NP26 3NB	Land	1.5 acres	Redwick Road			Too Small	
Bulwark Park	Bulwark Park, Rockwood Road, Chepstow, Monmouthshire, NP16 5JQ	Land	4.41 acres				Park, topography	Piggy's Hill
Carbonne Close Play Area	Carbonne Close Play Area, Monmouth, Monmouthshire, NP25 5EG	Land	1.5 acres	Monmouth Link Road				
Children's play area St Stephens Crescent	Children's play area St Stephens Crescent, Govilon, Abergavenny, Monmouthshire	Land	0.3 acres				Too small	
Chippenham Mead Playground	Chippenham Mead Playground, Monmouth, Monmouthshire, NP25 3UZ	Land						
Chippenham Mead Village Green	Chippenham Mead Village Green, Monmouth, Monmouthshire, NP25 3EQ	Land					Playing Fields	
Cross Ash Playing Field	Cross Ash Playing Field, Graig View, Cross Ash, Abergavenny, Monmouthshire, NP7 5	Land	0.6 acres				Too Small	



Dingestow Playing Field	Dingestow Playing Field, Monmouth, Monmouthshire, NP25 4JH	Land	1.03 acres				Too Small, outside development boundary	
Drybridge Nature Park	Drybridge Nature Park, Rockfield Road, Monmouth, Monmouthshire	Land					C1 Flood Risk	
Forge Road, Land adjacent to	Forge Road, Land adjacent to, Osbaston, Monmouth, Monmouthshire	Land	???				Fishing Rights	Fishing Rights over the River Monnow
Former Clydach School, land adjacent	Former Clydach School, land adjacent, Off Heads of the Valley Road, Clydach, Monmouth, Monmouthshire	Land					A465	
Goetre Hall Wood Picnic Site & Car Park	Goetre Hall Wood Picnic Site & Car Park, Saron Road, Goetre, Abergavenny, Monmouthshire	Land	N/A	N/A	N/A	N/A	Unsuitable	
Goldwire Lane Playground	Goldwire Lane Playground, Monmouth, Monmouthshire, NP25 5BG	Land	0.09 acres				Too small	
Grosvenor Road, Land at	Grosvenor Road, Land at, Abergavenny, Monmouthshire, NP7 6AH	Land					Too Small	
Hendre Close Playground	Hendre Close Playground, Monmouth, Monmouthshire, NP25 5AX	Land	0.80 acres	Brook Estate, Monmouth			Too small	
Lawrence Crescent Amenity Land	Lawrence Crescent Amenity Land, Caerwent, Caldicot, Monmouthshire, NP26 5N	Land					Too Small	
Lawrence Crescent Play area	Lawrence Crescent Play area, Caerwent, Caldicot, Monmouthshire, NP26 5NS	Land	0.55 acres	Dinham Road			Too Small	
Linda Vista Gardens	Linda Vista Gardens, Tudor Street, Abergavenny, Monmouthshire, NP7 5DL	Land					Historic Gardens & TAN 2 Flood Zone	
Llanellen King George Playing Fields	Llanellen, Llanellen, Abergavenny, Monmouthshire, NP7 9HN	Land					Area of Amenity Importance	
Llangybi Play Ground	Llangybi Play Ground, St Cybi Avenue, Llangybi, Usk, Monmouthshire, NP15 1TT	Land					Area of Amenity Importance	
Llantillio Pertholey Recreation Ground	Llantillio Pertholey Recreation Ground, Off Gwent Road, Mardy, Abergavenny, Monmouthshire	Land					Area of Amenity Importance	Mardy Park Recreation Ground
Llanvapley Recreation Ground	Llanvapley Recreation Ground, Abergavenny, Monmouthshire	Land					Let to third party, party flood zone	
Magor Recreation Ground	Magor Recreation Ground, Near Sycamore Terrace, Magor, Monmouthshire	Land					Flood Zone - Three Fields Site	
Main Road, Land at	Main Road, Land at, Undy, Magor, Monmouthshire, NP26 3EH	Land					Flood Zone - Three Fields Site	Three fields site
Monmouth Road, Land at	Monmouth Road, Land at, Usk, Monmouthshire	Land					Too Small	
Old Abergavenny Road, Land at	Old Abergavenny Road, Land at, Pencroesoped, Abergavenny, Monmouthshire, NP23 5L	Land					Too Small	
Old Hereford Road Playing Field	Old Hereford Road Playing Field, Abergavenny, Monmouthshire, NP7 6EL	Land					Area of Amenity Importance	
Picnic Site-Beech Hill	Picnic Site-Beech Hill, Chainbridge Road, Usk, Monmouthshire, NP15 1PP	Land	??	B4598			Too Small	
Picnic Site-Newbridge on Usk	Picnic Site-Newbridge on Usk, Off A449, Llantrissant, Usk, Monmouthshire, NP7 0L	Land	???				Too Small	
River Wye, Part of	River Wye, Part of, Adjacent A40, Monmouth, Monmouthshire, NP25 5L	Land	Restricted access				Unsuitable - Riiver Bed	
Roman Park View Play Area	Roman Park View Play Area, Trelleck, Monmouth, Monmouthshire, NP25 4RB	Land	0.47 acres				Too Small	
St Marys Church Yard	St Marys Church Yard, Monk Street, Abergavenny, Monmouthshire	Land					Church Yard	
Strongbow Road Play Area	Strongbow Road Play Area, Chepstow, Monmouthshire	Land	2.1 acres					
Swan Meadow Park	Swan Meadow Park, Lower Monk Street, Abergavenny, Monmouthshire, NP7 5HF	Land					Floods	
Sycamore Terrace Play Area	Sycamore Terrace Play Area, Magor, Monmouthshire, NP26 3ET	Land	0.47 acres				Too small	
The Bryn Play Area	The Bryn Play Area, Abergavenny, Monmouthshire, NP7 9AH	Land	2.6 acres					
The Quest Portskewett Playing Field	The Quest Portskewett Playing Field, Caldicot, Monmouthshire, NP26 5PR	Land					Too small	
Thornwell Football Pitch	Thornwell Football Pitch, Denbigh Drive, Chepstow, Monmouthshire	Land					Area of Amenity Importance	Burnt Barn Football Club
Underhill Playing Field Children's Play Area	Underhill Playing Field Children's Play Area, Abergavenny, Monmouthshire, NP7 6L	Land						Rother Avenue Children's Play Area
Union Road Playground	Union Road Playground, Abergavenny, Monmouthshire	Land	0.35 acres				Too small	
Woodland View Play Area	Woodland View Play Area, Monmouth, Monmouthshire, NP25 3JW	Land	0.59 acres					
Llanishen Village Hall & Playing Field	Llanishen Village Hall & Playing Field, Chepstow, Monmouthshire, NP16 6QE	Land and property	N/A	N/A	N/A	N/A	Unsuitable	The Glebe Fields
Portal Road, Land at	Portal Road, Land at, Monmouth, Monmouthshire	Land. Declared surplus and on the market	1.29 acres				Development Site	
Forge Hammer Inn, Land near	Forge Hammer Inn, Land near, Heads of the Valley Road, Gilwern, Abergavenny, Monmouthshire	Land?					A465	
Hardwick Recreation Ground	Hardwick Recreation Ground, Hardwick Avenue, Chepstow, Monmouthshire, NP16 6L	Land?	4.5 acres				Area of Amenity Importance	Severn Crescent/Hardwick Sports Ground
Severn Tunnel Junction, Land & former sidings at	Severn Tunnel Junction, Land & former sidings at, Rogiet, Caldicot, Monmouthshire	Land?					C1 Flood Zone, Area of Amenity Importance	Old Sidings
Former Chapel Chepstow Cemetery	The Chapel Chepstow Cemetery, Mathern Road, Bulwark, Chepstow, Monmouthshire	Operational asset.	N/A	N/A	N/A	N/A	Unsuitable	
The Chapel Monmouth Cemetery	The Chapel Monmouth Cemetery, Osbaston Road, Monmouth, Monmouthshire, NP25 5L	Operational asset.	N/A	N/A	N/A	N/A	Unsuitable	
Monnow Gatehouse Bridge		Property	N/A	N/A	N/A	N/A	Unsuitable	
1 Raglan Enterprise Park	Raglan Enterprise Park, 1, Chepstow Road, Raglan, Monmouthshire, NP15 2ER	Property - therefore unsuitable	N/A	N/A	N/A	N/A	Unsuitable	
1 Wonastow Road Plot	Wonastow Road Plot 1, Wonastow Road Industrial Estate, Monmouth, Monmouthshire	Property - therefore unsuitable	N/A	N/A	N/A	N/A	Unsuitable	
10a Old Pill Farm Industrial Estate	Old Pill Farm Industrial Estate, 10a, Caldicot, Monmouthshire, NP26 5JH	Property - therefore unsuitable	N/A	N/A	N/A	N/A	Unsuitable	
10a Pill Farm Industrial Estate	Unit 10a, Pill Farm Industrial Estate, Caldicot, Monmouthshire	Property - therefore unsuitable	N/A	N/A	N/A	N/A	Unsuitable	
10b Old Pill Farm Industrial Estate	Old Pill Farm Industrial Estate, 10b, Caldicot, Monmouthshire, NP26 5JH	Property - therefore unsuitable	N/A	N/A	N/A	N/A	Unsuitable	Pill Farm Depot
10b Pill Farm Industrial Estate	Unit 10b, Pill Farm Industrial Estate, Caldicot, Monmouthshire	Property - therefore unsuitable	N/A	N/A	N/A	N/A	Unsuitable	
1-21 Flats, Orchard Gardens	Orchard Gardens, Flats 1-21, Lower Church Street, Chepstow, Monmouthshire, NP23 5L	Property - therefore unsuitable	N/A	N/A	N/A	N/A	Unsuitable	
13 Castle Wood	13 Castlewood, 13 Castlewood, Usk, Monmouthshire, NP15 1SR	Property - therefore unsuitable	N/A	N/A	N/A	N/A	Unsuitable	
14 Castle Wood	14 Castlewood, 14 Castlewood, Usk, Monmouthshire, NP15 1SR	Property - therefore unsuitable	N/A	N/A	N/A	N/A	Unsuitable	
15 Castle Wood	15 Castlewood, 15 Castlewood, Usk, Monmouthshire, NP15 1SR	Property - therefore unsuitable	N/A	N/A	N/A	N/A	Unsuitable	
16 Castle Wood	16 Castlewood, 16 Castlewood, Usk, Monmouthshire, NP15 1SR	Property - therefore unsuitable	N/A	N/A	N/A	N/A	Unsuitable	
17 Castle Wood	17 Castlewood, 17 Castlewood, Usk, Monmouthshire, NP15 1SR	Property - therefore unsuitable	N/A	N/A	N/A	N/A	Unsuitable	
18 Castle Wood	18 Castlewood, 18 Castlewood, Usk, Monmouthshire, NP15 1SR	Property - therefore unsuitable	N/A	N/A	N/A	N/A	Unsuitable	
19 Castle Wood	19 Castlewood, 19 Castlewood, Usk, Monmouthshire, NP15 1SR	Property - therefore unsuitable	N/A	N/A	N/A	N/A	Unsuitable	
1a Old Pill Farm Industrial Estate - Ground Floor	Old Pill Farm Industrial Estate, 1a - Rms 1,2 & 4, Caldicot, Monmouthshire, NP26 5JH	Property - therefore unsuitable	N/A	N/A	N/A	N/A	Unsuitable	
1a Pill Farm Industrial Estate	Pill Farm Industrial Estate, 1a, Caldicot, Monmouthshire	Property - therefore unsuitable	N/A	N/A	N/A	N/A	Unsuitable	
1b Old Pill Farm Industrial Estate - 1st Floor	Old Pill Farm Industrial Estate, 1b, Caldicot, Monmouthshire, NP26 5JH	Property - therefore unsuitable	N/A	N/A	N/A	N/A	Unsuitable	
1b Pill Farm Industrial Estate	Pill Farm Industrial Estate, 1b, Caldicot, Monmouthshire, NP26 5JH	Property - therefore unsuitable	N/A	N/A	N/A	N/A	Unsuitable	
2 Old Pill Farm Industrial Estate	Old Pill Farm Industrial Estate, 2, Caldicot, Monmouthshire, NP26 5JH	Property - therefore unsuitable	N/A	N/A	N/A	N/A	Unsuitable	
2 Pill Farm Industrial Estate	Pill Farm Industrial Estate, 2, Caldicot, Monmouthshire, NP26 5JH	Property - therefore unsuitable	N/A	N/A	N/A	N/A	Unsuitable	
2 Raglan Enterprise Park	Raglan Enterprise Park, 2, Chepstow Road, Raglan, Monmouthshire, NP15 2JB	Property - therefore unsuitable	N/A	N/A	N/A	N/A	Unsuitable	
20 Castle Wood	20 Castlewood, 20 Castlewood, Usk, Monmouthshire, NP15 1SR	Property - therefore unsuitable	N/A	N/A	N/A	N/A	Unsuitable	
21 Castle Wood	21 Castle Wood, Usk, Monmouthshire, NP15 1SR	Property - therefore unsuitable	N/A	N/A	N/A	N/A	Unsuitable	
22 Castle Wood	22 Castlewood, 22 Castlewood, Usk, Monmouthshire, NP15 1SR	Property - therefore unsuitable	N/A	N/A	N/A	N/A	Unsuitable	
23 Castle Wood	23 Castlewood, 23 Castlewood, Usk, Monmouthshire, NP15 1SR	Property - therefore unsuitable	N/A	N/A	N/A	N/A	Unsuitable	
25/26a High Street	High Street, 25/26a, Abergavenny, Monmouthshire, NP7 5RY	Property - therefore unsuitable	N/A	N/A	N/A	N/A	Unsuitable	
3 Langley Close, Land at the rear of	Langley Close 3, Land at the rear of, Magor, Monmouthshire, NP26 3HW	Property - therefore unsuitable	N/A	N/A	N/A	N/A	Unsuitable	
3 Pill Farm Industrial Estate	Pill Farm Industrial Estate, 3, Caldicot, Monmouthshire, NP26 5JH	Property - therefore unsuitable	N/A	N/A	N/A	N/A	Unsuitable	
3 Raglan Enterprise Park	Raglan Enterprise Park, 3, Chepstow Road, Raglan, Monmouthshire, NP15 2JB	Property - therefore unsuitable	N/A	N/A	N/A	N/A	Unsuitable	
30 Herbert Road	Herbert Road, 30, Caldicot, Monmouthshire, NP26 4PP	Property - therefore unsuitable	N/A	N/A	N/A	N/A	Unsuitable	

35 Highfield	Highfield, 35, Goetre, Abergavenny, Monmouthshire, NP4 0BH	Property - therefore unsuitable	N/A	N/A	N/A	N/A	Unsuitable	
35 Old Hereford Road	Old Hereford Road, 35, Abergavenny, Monmouthshire, NP7 6EL	Property - therefore unsuitable	N/A	N/A	N/A	N/A	Unsuitable	
39 Budden Crescent	Budden Crescent, 39, Caldicot, Monmouthshire, NP26 4PP	Property - therefore unsuitable	N/A	N/A	N/A	N/A	Unsuitable	
3a Old Pill Farm Industrial Estate	Old Pill Farm Industrial Estate, 3a, Caldicot, Monmouth, NP26 5JH	Property - therefore unsuitable	N/A	N/A	N/A	N/A	Unsuitable	
3b Old Pill Farm Industrial Estate	Old Pill Farm Industrial Estate, 3b, Caldicot, Monmouthshire, NP26 5JH	Property - therefore unsuitable	N/A	N/A	N/A	N/A	Unsuitable	
4 Llangovan	Llangovan 4, Old Trecastle Farm, Llangovan, Monmouth, Monmouthshire, NP25 4	Property - therefore unsuitable	N/A	N/A	N/A	N/A	Unsuitable	Old Trecastle Farm
4 Newport Road, land adjacent to	Newport Road, 4, land adjacent to, Caldicot, Monmouthshire, NP26 4AE	Property - therefore unsuitable	N/A	N/A	N/A	N/A	Unsuitable	
4 Pill Farm Industrial Estate	Pill Farm Industrial Estate, 4, Caldicot, Monmouthshire, NP26 5JH	Property - therefore unsuitable	N/A	N/A	N/A	N/A	Unsuitable	
4 Raglan Enterprise Park	Raglan Enterprise Park, 4, Chepstow Road, Raglan, Monmouthshire, NP15 2JB	Property - therefore unsuitable	N/A	N/A	N/A	N/A	Unsuitable	
4a Old Pill Farm Industrial Estate	Old Pill Farm Industrial Estate, 4a, Caldicot, Monmouthshire, NP26 5JH	Property - therefore unsuitable	N/A	N/A	N/A	N/A	Unsuitable	
4b Old Pill Farm Industrial Estate	Old Pill Farm Industrial Estate, 4b, Caldicot, Monmouthshire, NP26 5JH	Property - therefore unsuitable	N/A	N/A	N/A	N/A	Unsuitable	
4c Old Pill Farm Industrial Estate	Old Pill Farm Industrial Estate, 4c, Caldicot, Monmouthshire, NP26 5JH	Property - therefore unsuitable	N/A	N/A	N/A	N/A	Unsuitable	
4d Old Pill Farm Industrial Estate	Old Pill Farm Industrial Estate, 4d, Caldicot, Monmouthshire, NP26 5JH	Property - therefore unsuitable	N/A	N/A	N/A	N/A	Unsuitable	
5 Dancing Close, Land to the rear of	Dancing Close , 5, Land to the rear of, Undy, Magor, Monmouthshire, NP26 3JT	Property - therefore unsuitable	N/A	N/A	N/A	N/A	Unsuitable	
5 Pill Farm Industrial Estate	Pill Farm Industrial Estate, 5, Caldicot, Monmouthshire	Property - therefore unsuitable	N/A	N/A	N/A	N/A	Unsuitable	
5 Raglan Enterprise Park	Raglan Enterprise Park, 5, Chepstow Road, Raglan, Monmouthshire, NP15 2JB	Property - therefore unsuitable	N/A	N/A	N/A	N/A	Unsuitable	
54a Bulwark Road	Bulwark Road, 54a, Chepstow, Monmouthshire, NP16 5JW	Property - therefore unsuitable	N/A	N/A	N/A	N/A	Unsuitable	
5a Castle Way	Castle Way, 5a, Portskewett, Caldicot, Monmouthshire, NP26 5PR	Property - therefore unsuitable	N/A	N/A	N/A	N/A	Unsuitable	
5b (& c) Castle Way	Castle Way, 5b (& c), Portskewett, Caldicot, Monmouthshire, NP26 5PR	Property - therefore unsuitable	N/A	N/A	N/A	N/A	Unsuitable	
5c (& b) Castle Way	Castle Way, 5c (& b), Portskewett, Caldicot, NP26 5PR	Property - therefore unsuitable	N/A	N/A	N/A	N/A	Unsuitable	
5d Castle Way	Castle Way, 5d, Portskewett, Caldicot, Monmouthshire, NP26 5PR	Property - therefore unsuitable	N/A	N/A	N/A	N/A	Unsuitable	
5e Castle Way	Castle Way, 5e, Portskewett, Caldicot, Monmouthshire, NP26 5PR	Property - therefore unsuitable	N/A	N/A	N/A	N/A	Unsuitable	
5f Castle Way	Castle Way, 5f, Portskewett, Caldicot, Monmouthshire, NP26 5PR	Property - therefore unsuitable	N/A	N/A	N/A	N/A	Unsuitable	
5g Castle Way	Castle Way, 5g, Portskewett, Caldicot, Monmouthshire, NP26 5PR	Property - therefore unsuitable	N/A	N/A	N/A	N/A	Unsuitable	
5h Castle Way	Castle Way, 5h, Portskewett, Caldicot, Monmouthshire, NP26 5PR	Property - therefore unsuitable	N/A	N/A	N/A	N/A	Unsuitable	
6 Old Pill Farm Industrial Estate	Old Pill Farm Industrial Estate, 6, Caldicot, Monmouthshire, NP26 5JH	Property - therefore unsuitable	N/A	N/A	N/A	N/A	Unsuitable	
6 Pill Farm Industrial Estate	Pill Farm Industrial Estate, 6, Caldicot, Monmouthshire, NP26 5XE	Property - therefore unsuitable	N/A	N/A	N/A	N/A	Unsuitable	
6 Raglan Enterprise Park	Raglan Enterprise Park, 6, Chepstow Road, Raglan, Monmouthshire, NP15 2JB	Property - therefore unsuitable	N/A	N/A	N/A	N/A	Unsuitable	
7 Raglan Enterprise Park	Raglan Enterprise Park, 7, Chepstow Road, Raglan, Monmouthshire, NP15 2JB	Property - therefore unsuitable	N/A	N/A	N/A	N/A	Unsuitable	
7a Old Pill Farm Industrial Estate	Old Pill Farm Industrial Estate, 7a, Caldicot, Monmouthshire, NP26 5JH	Property - therefore unsuitable	N/A	N/A	N/A	N/A	Unsuitable	
7b Old Pill Farm Industrial Estate	Old Pill Farm Industrial Estate, 7b, Caldicot, Monmouthshire, NP26 5JH	Property - therefore unsuitable	N/A	N/A	N/A	N/A	Unsuitable	
8 Llangovan	Llangovan 8, Old Llanishen Farm, Llangovan, Monmouth, NP25 4BU	Property - therefore unsuitable	N/A	N/A	N/A	N/A	Unsuitable	
8a Old Pill Farm Industrial Estate	Old Pill Farm Industrial Estate, 8a, Caldicot, Monmouthshire, NP26 5JH	Property - therefore unsuitable	N/A	N/A	N/A	N/A	Unsuitable	
8b Old Pill Farm Industrial Estate	Old Pill Farm Industrial Estate, 8b, Caldicot, Monmouthshire, NP26 5JH	Property - therefore unsuitable	N/A	N/A	N/A	N/A	Unsuitable	
8c Old Pill Farm Industrial Estate	Old Pill Farm Industrial Estate, 8c, Caldicot, Monmouthshire, NP26 5JH	Property - therefore unsuitable	N/A	N/A	N/A	N/A	Unsuitable	
8d Old Pill Farm Industrial Estate	Old Pill Farm Industrial Estate, 8d, Caldicot, Monmouthshire, NP26 5JH	Property - therefore unsuitable	N/A	N/A	N/A	N/A	Unsuitable	
9 Old Pill Farm Industrial Estate	Old Pill Farm Industrial Estate, 9, Caldicot, Monmouthshire, NP26 5JH	Property - therefore unsuitable	N/A	N/A	N/A	N/A	Unsuitable	
9 Pill Farm Industrial Estate	Pill Farm Industrial Estate, 9, Caldicot, Monmouthshire, NP26 5XE	Property - therefore unsuitable	N/A	N/A	N/A	N/A	Unsuitable	
Abergavenny Borough Theatre	Abergavenny Borough Theatre, Cross Street, Abergavenny, Monmouthshire, NP7 5HD	Property - therefore unsuitable	N/A	N/A	N/A	N/A	Unsuitable	Town Hall
Abergavenny Borough Theatre		Property - therefore unsuitable	N/A	N/A	N/A	N/A	Unsuitable	
Abergavenny Cattle Market Development Site	Cattle Market Development Site, Priory Lane, Abergavenny, Monmouthshire, NP7 5SG	Property - therefore unsuitable	N/A	N/A	N/A	N/A	Unsuitable	Priory Lane, Land at
Abergavenny Girl Guides Hut	Abergavenny Girl Guides Hut, Fairfield, Abergavenny, Monmouthshire, NP7 5SG	Property - therefore unsuitable	N/A	N/A	N/A	N/A	Unsuitable	
Abergavenny Leisure Centre	Abergavenny Leisure Centre, Old Hereford Road, Abergavenny, Monmouthshire,	Property - therefore unsuitable	N/A	N/A	N/A	N/A	Unsuitable	
Abergavenny Library	Abergavenny Library, Baker Street, Abergavenny, Monmouthshire, NP7 5BD	Property - therefore unsuitable	N/A	N/A	N/A	N/A	Unsuitable	
Abergavenny Market	Abergavenny Market, Cross Street, Abergavenny, Monmouthshire, NP7 5HD	Property - therefore unsuitable	N/A	N/A	N/A	N/A	Unsuitable	
Abergavenny Museum & Castle	Abergavenny Museum & Castle, Castle Street, Abergavenny, Monmouthshire, NP7 5HD	Property - therefore unsuitable	N/A	N/A	N/A	N/A	Unsuitable	
Abergavenny Senior Citizens	Abergavenny Senior Citizens, Park Road, Abergavenny, Monmouthshire, NP7 5TD	Property - therefore unsuitable	N/A	N/A	N/A	N/A	Unsuitable	OAP Community Building
Abergavenny Town Hall	Abergavenny Town Hall, Cross Street, Abergavenny, Monmouthshire, NP7 5HD	Property - therefore unsuitable	N/A	N/A	N/A	N/A	Unsuitable	
Abergavenny Youth & Community Education Centre	Abergavenny Youth & Community Education Centre, Old Hereford Road, Abergavenny, Monmouthshire, NP7 5HD	Property - therefore unsuitable	N/A	N/A	N/A	N/A	Unsuitable	Former Ysgol Gymraeg Y Fenni
Angiddy Ironworks	Angiddy Ironworks, Tintern, Monmouthshire, NP16 6TU	Property - therefore unsuitable	N/A	N/A	N/A	N/A	Unsuitable	
Arch R W Church in Wales Primary Playing Field	Arch R W Church in Wales Primary Playing Field, Church Road, Portskewett, Caldicot, Monmouthshire, NP26 5JH	Property - therefore unsuitable	N/A	N/A	N/A	N/A	Unsuitable	ARWP
Archbishop Rowan Williams Church in Wales Primary Playing Field	Archbishop Rowan Williams Church in Wales Primary, Church Road, Portskewett, Caldicot, Monmouthshire, NP26 5JH	Property - therefore unsuitable	N/A	N/A	N/A	N/A	Unsuitable	ARWP
ATC HQ	ATC HQ, Jubilee Way, Caldicot, Monmouthshire, NP26 4NA	Property - therefore unsuitable	N/A	N/A	N/A	N/A	Unsuitable	
Bailey Park Garage	Bailey Park Garage, Abergavenny, Monmouthshire, NP7 5SG	Property - therefore unsuitable	N/A	N/A	N/A	N/A	Unsuitable	
Bailey Park Pavillion	Bailey Park Pavillion, Bailey Park, Abergavenny, Monmouthshire, NP7 5SG	Property - therefore unsuitable	N/A	N/A	N/A	N/A	Unsuitable	
Black Ash Path	Black Ash Path, Wye Crescent, Chepstow, Monmouthshire	Property - therefore unsuitable	N/A	N/A	N/A	N/A	Unsuitable	Craig yr Afon
Blackrock, Land at	Blackrock, Land at, portskewett, Caldicot, Monmouthshire	Property - therefore unsuitable	N/A	N/A	N/A	N/A	Unsuitable	
Block B Ground Floor Mamhilad House	Block B Ground Floor Mamhilad House, Mamhilad Park Estate, Pontypool, Torfaen, NP23 5JH	Property - therefore unsuitable	N/A	N/A	N/A	N/A	Unsuitable	
Boat House River Wye	Boat House River Wye, Monmouth, Monmouthshire, NP25 3DP	Property - therefore unsuitable	N/A	N/A	N/A	N/A	Unsuitable - let to rowing club	
Bryn Y Cwm One Stop Shop	Abergavenny Hub, Cross Street, Abergavenny, Monmouthshire, NP7 5HD	Property - therefore unsuitable	N/A	N/A	N/A	N/A	Unsuitable	
Bulwark Avenue Bus Shelter	Bulwark Avenue Bus Shelter, Opp. Alpha Road, Bulwark, Chepstow, Monmouthshire, NP23 5JH	Property - therefore unsuitable	N/A	N/A	N/A	N/A	Unsuitable	
Bulwark Community Centre	Bulwark Community Centre, Laburnum Way, Bulwark, Chepstow, Monmouthshire, NP23 5JH	Property - therefore unsuitable	N/A	N/A	N/A	N/A	Unsuitable	
Bulwark Road Bus Shelter	Bulwark Road Bus Shelter, Bulwark, Chepstow, Monmouthshire	Property - therefore unsuitable	N/A	N/A	N/A	N/A	Unsuitable	
Bulwark Senior Citizens Club	Bulwark Senior Citizens Club, 27 Cromwell Road, Bulwark, Chepstow, Monmouthshire, NP23 5JH	Property - therefore unsuitable	N/A	N/A	N/A	N/A	Unsuitable	
Burnt Barn Road Bus Shelter	Burnt Barn Road Bus Shelter, Chepstow, Monmouthshire	Property - therefore unsuitable	N/A	N/A	N/A	N/A	Unsuitable	
Burnt Barn Road Bus Stop	Burnt Barn Road Bus Stop, Chepstow, Monmouthshire	Property - therefore unsuitable	N/A	N/A	N/A	N/A	Unsuitable	
Bus Shelter adjacent to Fairview & Bank House	Bus Shelter adjacent to Fairview & Bank House, High Street, Raglan, Monmouthshire, NP26 5JH	Property - therefore unsuitable	N/A	N/A	N/A	N/A	Unsuitable	
Caldicot Area Housing Office	Caldicot Area Housing Office, Woodstock Way, Caldicot, Monmouthshire, NP26 5JH	Property - therefore unsuitable	N/A	N/A	N/A	N/A	Unsuitable	
Caldicot Castle Country Park & Museum	Caldicot Castle Country Park & Museum, Church Road, Caldicot, Monmouthshire, NP26 5JH	Property - therefore unsuitable	N/A	N/A	N/A	N/A	Unsuitable	
Caldicot Castle Warden Depot	Caldicot Castle Warden Depot, Church Road, Caldicot, Monmouthshire, NP26 5JH	Property - therefore unsuitable	N/A	N/A	N/A	N/A	Unsuitable	
Caldicot Citizens Advice Bureau	5a Church Road, Caldicot, Monmouthshire, NP26 4BP	Property - therefore unsuitable	N/A	N/A	N/A	N/A	Unsuitable	
Caldicot Grounds Maintenance Depot	Caldicot Grounds Maintenance Depot, Caldicot, Monmouthshire, NP26 5DB	Property - therefore unsuitable	N/A	N/A	N/A	N/A	Unsuitable	Mill Lane Depot (Eastern)

Caldicot Hub	Caldicot Hub, Woodstock Way, Caldicot, Monmouthshire, NP26 5DB	Property - therefore unsuitable	N/A	N/A	N/A	N/A	N/A	Unsuitable	
Caldicot Leisure Centre Mill Lane Caldicot	Caldicot Leisure Centre Mill Lane Caldicot, Mill Lane, Caldicot, Monmouthshire, NP26 4NA	Property - therefore unsuitable	N/A	N/A	N/A	N/A	N/A	Unsuitable	
Caldicot Luncheon Centre	Caldicot Luncheon Centre, Sandy Lane, Caldicot, Monmouthshire, NP26 4NA	Property - therefore unsuitable	N/A	N/A	N/A	N/A	N/A	Unsuitable	
Caldicot Male Voice Choir	Caldicot Male Voice Choir, Caldicot Comprehensive School, Mill Lane, Caldicot, Monmouthshire, NP26 4NA	Property - therefore unsuitable	N/A	N/A	N/A	N/A	N/A	Unsuitable	
Caldicot Pre-School Playgroup	Caldicot Pre-School Playgroup, Caldicot Comprehensive School, Mill Lane, Caldicot, Monmouthshire, NP26 4NA	Property - therefore unsuitable	N/A	N/A	N/A	N/A	N/A	Unsuitable	Little Stars
Caldicot School	Caldicot School, Mill Lane, Caldicot, Monmouthshire, NP26 5XA	Property - therefore unsuitable	N/A	N/A	N/A	N/A	N/A	Unsuitable	
Calditots Flying Start	Former Caldicot West End School Site, Calditots Flying Start, Masefield Road, Caldicot, Monmouthshire, NP26 4NA	Property - therefore unsuitable	N/A	N/A	N/A	N/A	N/A	Unsuitable	
Cantref Primary School & Nursery Unit	Cantref Primary School & Nursery Unit, Harold Road, Abergavenny, NP7 7DG	Property - therefore unsuitable	N/A	N/A	N/A	N/A	N/A	Unsuitable	Harold Rd. Junior & Special Needs Unit
Castle Park Nursery (Hall Park unders 5's Red Robins)	Castle Park Nursery (Hall Park unders 5's Red Robins), The Demountable, Church Road, Abergavenny, Monmouthshire, NP7 8PL	Property - therefore unsuitable	N/A	N/A	N/A	N/A	N/A	Unsuitable	Former Caldicot St Mary's Nursery
Castle Park Primary	Castle Park Primary, Church Road, Caldicot, Monmouthshire, NP26 4HN	Property - therefore unsuitable	N/A	N/A	N/A	N/A	N/A	Unsuitable	Former Caldicot St Mary's Junior & Special Needs Unit
Castlegate Business Park	Castlegate Business Park, Caldicot, NP26 5YR	Property - therefore unsuitable	N/A	N/A	N/A	N/A	N/A	Unsuitable	
Central Monmouthshire One Stop Shop	Market Hall, Mer Central Monmouthshire One Stop Shop, Priory Street, Monmouth, Monmouthshire, NP23 5EX	Property - therefore unsuitable	N/A	N/A	N/A	N/A	N/A	Unsuitable	
Chepstow Comprehensive - Service Tenancy	Chepstow Comprehensive - Service Tenancy, School Bungulow, Welsh Street, Chepstow, Monmouthshire, NP16 5EZ	Property - therefore unsuitable	N/A	N/A	N/A	N/A	N/A	Unsuitable	
Chepstow Drill Hall	Chepstow Drill Hall, The Drill Hall, Lower Church Street, Chepstow, Monmouthshire, NP16 5HJ	Property - therefore unsuitable	N/A	N/A	N/A	N/A	N/A	Unsuitable	Former Chepstow Education Resource Centre
Chepstow Drill Hall Boxing Club	Chepstow Drill Hall Boxing Club, Lower Church Street, Chepstow, NP16 5HJ	Property - therefore unsuitable	N/A	N/A	N/A	N/A	N/A	Unsuitable	
Chepstow Hub and Contact Centre	Chepstow Hub and Contact Centre, Manor Way, Chepstow, NP16 5HZ	Property - therefore unsuitable	N/A	N/A	N/A	N/A	N/A	Unsuitable	
Chepstow Leisure Centre	Chepstow Leisure Centre, Crossway Green, Welsh Street, Chepstow, Monmouthshire, NP16 5EZ	Property - therefore unsuitable	N/A	N/A	N/A	N/A	N/A	Unsuitable	
Chepstow Museum	Chepstow Museum, Bridge Street, Chepstow, Monmouthshire, NP16 5EZ	Property - therefore unsuitable	N/A	N/A	N/A	N/A	N/A	Unsuitable	
Chepstow School	Chepstow School, Welsh Street, Chepstow, Monmouthshire, NP16 5LR	Property - therefore unsuitable	N/A	N/A	N/A	N/A	N/A	Unsuitable	Chepstow Comprehensive
Chepstow Senior Citizens Centre	Chepstow Senior Citizens Centre, Place De Corneilles, Chepstow, Monmouthshire, NP16 5EZ	Property - therefore unsuitable	N/A	N/A	N/A	N/A	N/A	Unsuitable	
Children's Services Contact Centre	Children's Services Contact Centre, Caldicot, Monmouthshire, NP26 4BN	Property - therefore unsuitable	N/A	N/A	N/A	N/A	N/A	Unsuitable	Adult Education Centre Caldicot Comprehensive
Children's Services Contact Centre	King Henry VIII Comprehensive - Service Tenancy, School Bungulow, King Henry VIII Comprehensive, Monmouth, Monmouthshire, NP23 5EX	Property - therefore unsuitable	N/A	N/A	N/A	N/A	N/A	Unsuitable	
Chippenham Mead Groundmans Hut	Chippenham Mead Groundmans Hut, Old Cattle Market, Monmouth Sports Ground, Monmouth, Monmouthshire, NP25 4HX	Property - therefore unsuitable	N/A	N/A	N/A	N/A	N/A	Unsuitable	Monmouth Sports Ground Shed/Monmouth bowls
Civic Amenity - Usk	Civic Amenity - Usk, Maryport Street, Usk, Monmouthshire, NP25 4HX	Property - therefore unsuitable	N/A	N/A	N/A	N/A	N/A	Unsuitable	
Clydach Ironworks	Clydach Ironworks, Abergavenny, Monmouthshire, NP23 4XT	Property - therefore unsuitable	N/A	N/A	N/A	N/A	N/A	Unsuitable	
Colomendy	Colomendy, Colomendy, Llanfair Discoed, Chepstow, Monmouthshire, NP16 6LL	Property - therefore unsuitable	N/A	N/A	N/A	N/A	N/A	Unsuitable	XCT02
County Hall Cwmbran	County Hall, Cwmbran, Torfaen, NP44 2XH	Property - therefore unsuitable	N/A	N/A	N/A	N/A	N/A	Unsuitable	
Cross Ash Primary School	Cross Ash Primary School, Cross Ash, Abergavenny, Monmouthshire, NP7 8PL	Property - therefore unsuitable	N/A	N/A	N/A	N/A	N/A	Unsuitable	
Cross Ash Village Hall	Cross Ash Village Hall, Abergavenny, Monmouthshire, NP7 8PL	Property - therefore unsuitable	N/A	N/A	N/A	N/A	N/A	Unsuitable	
Cylch Meithrin y Fenni	Cylch Meithrin y Fenni, The Demountable, Ysgol y Gymraeg, Abergavenny, Monmouthshire, NP7 8PL	Property - therefore unsuitable	N/A	N/A	N/A	N/A	N/A	Unsuitable	
Cylch Meithrin y Ffin	Cylch Meithrin y Ffin, Sandy Lane, Sandy Lane, Caldicot, Monmouthshire, NP26 4NA	Property - therefore unsuitable	N/A	N/A	N/A	N/A	N/A	Unsuitable	
Deri View Junior & Infants	Deri View Junior & Infants, Charles Close, Abergavenny, Monmouthshire, NP7 6AA	Property - therefore unsuitable	N/A	N/A	N/A	N/A	N/A	Unsuitable	Butterflies Playgroup/Acorns ICC
Dewstow Primary School	Dewstow Primary School, Green Lane, Caldicot, Monmouthshire, NP26 4HD	Property - therefore unsuitable	N/A	N/A	N/A	N/A	N/A	Unsuitable	
Drybridge House/ Bridges Community Centre	Drybridge House/ Bridges Community Centre, Drybridge Park, Monmouth, Monmouthshire, NP25 4HX	Property - therefore unsuitable	N/A	N/A	N/A	N/A	N/A	Unsuitable	Monnow Court Site
Durand Primary School	Durand Primary School, Alianore Road, Caldicot, NP26 5DF	Property - therefore unsuitable	N/A	N/A	N/A	N/A	N/A	Unsuitable	
Fairfield Depot	Fairfield Depot, Bailey Park, Abergavenny, Monmouthshire, NP7 5SG	Property - therefore unsuitable	N/A	N/A	N/A	N/A	N/A	Unsuitable	
Five Lanes Quarry waste disposal site	Five Lanes Quarry waste disposal site, Chepstow, Monmouthshire, NP26 5PD	Property - therefore unsuitable	N/A	N/A	N/A	N/A	N/A	Unsuitable	
Former Abergavenny Tourist Information Centre	Former Abergavenny Tourist Information Centre, 24 Monmouth Road, Abergavenny, Monmouthshire, NP7 8PL	Property - therefore unsuitable	N/A	N/A	N/A	N/A	N/A	Unsuitable	
Former Chepstow Tourist Information Centre	Former Chepstow Tourist Information Centre, Castle Car Park, Bridge Street, Chepstow, Monmouthshire, NP16 5EZ	Property - therefore unsuitable	N/A	N/A	N/A	N/A	N/A	Unsuitable	
Former Park Street Infants School	Former Park Street Infants School, Park Street, Abergavenny, Monmouthshire, NP7 5YB	Property - therefore unsuitable	N/A	N/A	N/A	N/A	N/A	Unsuitable	
Former Usk Mortuary	Former Usk Mortuary, Mill Street, Usk, Monmouthshire	Property - therefore unsuitable	N/A	N/A	N/A	N/A	N/A	Unsuitable	
Future Raglan Village Hall Site	Future Raglan Village Hall, Chepstow Road, Raglan, Monmouthshire, NP15 2EN	Property - therefore unsuitable	N/A	N/A	N/A	N/A	N/A	Unsuitable	Former Raglan Voluntary Controlled Primary
Gilwern Community Centre	Gilwern Community Centre, School Lane, Gilwern, Monmouthshire, NP7 0AT	Property - therefore unsuitable	N/A	N/A	N/A	N/A	N/A	Unsuitable	Gilwern Adult Education Centre
Gilwern Community Education Centre	Gilwern Community Education Centre, Upper Common, Gilwern, Monmouthshire, NP7 0AT	Property - therefore unsuitable	N/A	N/A	N/A	N/A	N/A	Unsuitable	
Gilwern Junior & Infants - Service Tenancy	Gilwern Junior & Infants - Service Tenancy, School Bungulow, Cae Meldon, Gilwern, Monmouthshire, NP7 0AY	Property - therefore unsuitable	N/A	N/A	N/A	N/A	N/A	Unsuitable	
Gilwern Library	Gilwern Library, Upper Common, Gilwern, Monmouthshire, NP7 0DS	Property - therefore unsuitable	N/A	N/A	N/A	N/A	N/A	Unsuitable	
Gilwern Park Industrial Estate	Gilwern Park Industrial Estate, Ty Mawr Road, Gilwern, Abergavenny, Monmouthshire, NP7 0AY	Property - therefore unsuitable	N/A	N/A	N/A	N/A	N/A	Unsuitable	
Gilwern Primary	Gilwern Primary, Cae Meldon, Gilwern, Abergavenny, NP7 0AY	Property - therefore unsuitable	N/A	N/A	N/A	N/A	N/A	Unsuitable	
Goytre Fawr Playgroup	Goytre Fawr Playgroup, Old School Buildings, Goytre, Abergavenny, Monmouthshire, NP7 8PL	Property - therefore unsuitable	N/A	N/A	N/A	N/A	N/A	Unsuitable	Jack & Jill
Goytre Fawr Primary School	Goytre Fawr Primary School, Penperffeni, Pontypool, NP4 0AH	Property - therefore unsuitable	N/A	N/A	N/A	N/A	N/A	Unsuitable	
Gwehelog Bus Shelter	Gwehelog Bus Shelter, Opp. The Hall Inn, Gwehelog, Usk, Monmouthshire	Property - therefore unsuitable	N/A	N/A	N/A	N/A	N/A	Unsuitable	
Hadnock Road Industrial Estate	Hadnock Road Industrial Estate, Monmouth, Monmouthshire	Property - therefore unsuitable	N/A	N/A	N/A	N/A	N/A	Unsuitable	
Hanbury House, Welsh St	Hanbury House, Welsh St, Welsh Street, Chepstow, NP16 5LL	Property - therefore unsuitable	N/A	N/A	N/A	N/A	N/A	Unsuitable	
Hopscotch Nursery	Hopscotch Nursery, New School Road, Gilwern, Abergavenny, NP7 0AY	Property - therefore unsuitable	N/A	N/A	N/A	N/A	N/A	Unsuitable	
Innovation House (Magor 1)	Innovation House (Magor 1) & Overflow Car Park, Monmouthshire County Council, Magor, Monmouthshire, NP26 5EG	Property - therefore unsuitable	N/A	N/A	N/A	N/A	N/A	Unsuitable	
King Henry VIII Comprehensive	King Henry VIII Comprehensive, Old Hereford Road, Abergavenny, Monmouthshire, NP7 8PL	Property - therefore unsuitable	N/A	N/A	N/A	N/A	N/A	Unsuitable	
Kymin View Primary School	Kymin View Primary School, Wyesham Road, Monmouth, Monmouthshire, NP25 3JL	Property - therefore unsuitable	N/A	N/A	N/A	N/A	N/A	Unsuitable	
Land adjoining 2 Chestnut Court	Land adjoining 2 Chestnut Court, Wyesham, Monmouth, Monmouthshire, NP25 3JL	Property - therefore unsuitable	N/A	N/A	N/A	N/A	N/A	Unsuitable	
Linda Vista Workshop	Linda Vista Workshop, Tudor Street, Abergavenny, Monmouthshire, NP7 9DL	Property - therefore unsuitable	N/A	N/A	N/A	N/A	N/A	Unsuitable	
Llandogo Primary School	Llandogo Primary School, Llandogo, Monmouth, Monmouthshire, NP25 4TJ	Property - therefore unsuitable	N/A	N/A	N/A	N/A	N/A	Unsuitable	
Llandogo Village Hall, land at	Llandogo Village Hall, The Woodlands, Llandogo, Monmouth, Monmouthshire, NP25 4TJ	Property - therefore unsuitable	N/A	N/A	N/A	N/A	N/A	Unsuitable	Llandogo Millenium Hall
Llanfihangel Crucorney Primary	Llanfihangel Crucorney Primary, Werngifford, Pandy, Abergavenny, Monmouthshire, NP7 8PL	Property - therefore unsuitable	N/A	N/A	N/A	N/A	N/A	Unsuitable	
Llanfoist Cemetery Shed	Llanfoist Cemetery Shed, Llanfoist, Abergavenny, Monmouthshire	Property - therefore unsuitable	N/A	N/A	N/A	N/A	N/A	Unsuitable	
Llanfoist Fawr Primary School	Llanfoist Fawr Primary School, Gypsy Lane, Llanfoist, Abergavenny, NP7 9LS	Property - therefore unsuitable	N/A	N/A	N/A	N/A	N/A	Unsuitable	
Llanfoist Highways Depot	Llanfoist Highways Depot, Merthyr Road, Llanfoist, Abergavenny, Monmouthshire	Property - therefore unsuitable	N/A	N/A	N/A	N/A	N/A	Unsuitable	
Llanfoist Refuse Tip	Llanfoist Refuse Tip, Llanfoist, Abergavenny, Monmouthshire, NP7 9LH	Property - therefore unsuitable	N/A	N/A	N/A	N/A	N/A	Unsuitable	
Llanfoist Transfer Station	Llanfoist Transfer Station, Abergavenny, Monmouthshire, NP7 9AQ	Property - therefore unsuitable	N/A	N/A	N/A	N/A	N/A	Unsuitable	
Llangybi Bus Shelter	Llangybi Bus Shelter, Llangybi, Usk, Monmouthshire	Property - therefore unsuitable	N/A	N/A	N/A	N/A	N/A	Unsuitable	
Magor Scout & Guide Hut	Magor Scout & Guide Hut, Brassknocker Street, Caldicot, Monmouthshire, NP26 4NA	Property - therefore unsuitable	N/A	N/A	N/A	N/A	N/A	Unsuitable	
Magor VA Primary School Playing Fields	Magor VA Primary School Playing Fields, Magor, Monmouthshire, NP6 3EG	Property - therefore unsuitable	N/A	N/A	N/A	N/A	N/A	Unsuitable	
Manor Farm Crick Highways Depot	Manor Farm Crick Highways Depot, Crick, Caldicot, Monmouthshire, NP26 5UW	Property - therefore unsuitable	N/A	N/A	N/A	N/A	N/A	Unsuitable	
Melville Theatre	Melville Theatre, Pen y Pound Road, Abergavenny, Monmouthshire, NP7 5UD	Property - therefore unsuitable	N/A	N/A	N/A	N/A	N/A	Unsuitable	Gwent Theatre In Education/Gwent Drama Centre (Grofield)



Tiny Tots	Ysgol Gymraeg Y Fenni, St Davids Road, Abergavenny, Monmouthshire, NP7 6H	Property - therefore unsuitable	N/A	N/A	N/A	N/A	N/A	Unsuitable	Ysgol Gymraeg Y Fenni Flying Start
Trellech Primary School	Trellech Primary School, Trellech, Monmouth, NP25 4PA	Property - therefore unsuitable	N/A	N/A	N/A	N/A	N/A	Unsuitable	
Tudor Street Day Centre Abergavenny	Tudor Street Day Centre Abergavenny, Tudor Street, Abergavenny, Monmouthshire, NP7 6DL	Property - therefore unsuitable	N/A	N/A	N/A	N/A	N/A	Unsuitable	
Undy Nursery	Undy Nursery, Pennyfarthing Lane, Undy, Magor, Monmouthshire, NP26 3LZ	Property - therefore unsuitable	N/A	N/A	N/A	N/A	N/A	Unsuitable	Alphabet Playgroup
Undy Primary School	Undy Primary School, Pennyfarthing Lane, Undy, Magor, Monmouthshire, NP26 3LZ	Property - therefore unsuitable	N/A	N/A	N/A	N/A	N/A	Unsuitable	
Unit 102 Wales 1 Business Park	Unit 102 Wales 1 Business Park, Magor, Caldicot, Monmouthshire, NP26 9AN	Property - therefore unsuitable	N/A	N/A	N/A	N/A	N/A	Unsuitable	
Unit 10c Norman Way	Unit 10 Norman Way, Severnbridge Industrial Estate, Caldicot, Monmouthshire, NP26 4NA	Property - therefore unsuitable	N/A	N/A	N/A	N/A	N/A	Unsuitable	
Usk Church in Wales Primary (part) and Playing fields	Usk Church in Wales Primary (part) and Playing fields, Monmouth Road, Usk, Monmouthshire, NP15 1SE	Property - therefore unsuitable	N/A	N/A	N/A	N/A	N/A	Unsuitable	
Usk Church in Wales Primary Playing Field	Usk Church in Wales Primary, Monmouth Road, Usk, Monmouthshire, NP15 1SE	Property - therefore unsuitable	N/A	N/A	N/A	N/A	N/A	Unsuitable	
Usk Community Education Centre	18 Maryport Street, Usk, Monmouthshire, NP15 1AE	Property - therefore unsuitable	N/A	N/A	N/A	N/A	N/A	Unsuitable	
Usk Community Hub	Usk Youth Centre, 35 Maryport Street, Usk, Monmouthshire, NP15 1AE	Property - therefore unsuitable	N/A	N/A	N/A	N/A	N/A	Unsuitable	Former Usk Youth Centre
Usk Nursery	Usk Nursery, Monmouth Road, Usk, Monmouthshire, NP15 1SE	Property - therefore unsuitable	N/A	N/A	N/A	N/A	N/A	Unsuitable	
War Memorial	War Memorial, Corner of Regent Street and Frogmore Street, Abergavenny, Monmouthshire, NP7 6EH	Property - therefore unsuitable	N/A	N/A	N/A	N/A	N/A	Unsuitable	
War Memorial	War Memorial, Castle Hill, Monmouth, Monmouthshire	Property - therefore unsuitable	N/A	N/A	N/A	N/A	N/A	Unsuitable	
Weight Lifting Club Former Fire Station	Weight Lifting Club Former Fire Station, Lower Church Street, Chepstow, Monmouthshire, NP23 5JG	Property - therefore unsuitable	N/A	N/A	N/A	N/A	N/A	Unsuitable	
Wonastow Road Industrial Estate	Wonastow Road Industrial Estate, Monmouth, Monmouthshire, NP25 5AH	Property - therefore unsuitable	N/A	N/A	N/A	N/A	N/A	Unsuitable	
Wye Valley AONB Offices	Wye Valley AONB Offices, Hadnock Road, Mayhill, Monmouth, NP25 3NG	Property - therefore unsuitable	N/A	N/A	N/A	N/A	N/A	Unsuitable	
Ysgol Gymraeg Y Fenni	Ysgol Gymraeg Y Fenni, St Davids Road, Abergavenny, Monmouthshire, NP7 6H	Property - therefore unsuitable	N/A	N/A	N/A	N/A	N/A	Unsuitable	
Ysgol Gymraeg y Ffin	Ysgol y Ffin, Sandy Lane, Caldicot, NP26 4NA	Property - therefore unsuitable	N/A	N/A	N/A	N/A	N/A	Unsuitable	Former Caldicot Sandy Lane Infants & Nursery Unit
Caldicot Castle Football Pitch	Caldicot Castle Football Pitch, Castle Lea, Caldicot, Monmouthshire	Property and associated grounds	N/A	N/A	N/A	N/A	N/A	Unsuitable	
Catbrook Pavillion & Recreation Ground	Catbrook Pavillion & Recreation Ground, Wyles Wood Common, Catbrook, Chepstow, Monmouthshire, NP23 5JG	Property and associated grounds	N/A	N/A	N/A	N/A	N/A	Unsuitable	
Chepstow Athletic Club Sports Ground	Chepstow Athletic Club Sports Ground, Mathern Road, Chepstow, Monmouthshire, NP23 5JG	Property and associated grounds	N/A	N/A	N/A	N/A	N/A	Unsuitable	Mathern Road Recreation Ground
Chippenham Mead Pavillion & Sports Ground	Chippenham Mead Pavillion & Sports Ground, Monmouth, Monmouthshire, NP25 5AH	Property and associated grounds	N/A	N/A	N/A	N/A	N/A	Unsuitable	
Club House & Longfellow Road Playing Field	Club House & Longfellow Road Playing Field, Caldicot, Monmouthshire, NP26 4JJ	Property and associated grounds	N/A	N/A	N/A	N/A	N/A	Unsuitable	West End Playing Field
Football Club Jubilee Way Caldicot	Football Club Jubilee Way Caldicot, Caldicot, Monmouthshire, NP26 4NA	Property and associated grounds	N/A	N/A	N/A	N/A	N/A	Unsuitable	
Larkfield Playing Field (Chepstow AFC)	Larkfield Playing Field (Chepstow AFC), Chepstow Sports Ground, Bulwark, Chepstow, Monmouthshire, NP23 5JG	Property and associated grounds	N/A	N/A	N/A	N/A	N/A	Unsuitable	
Pen y Pound Recreation Ground	Pen y Pound Recreation Ground, Abergavenny, Monmouthshire, NP7 6EH	Property and associated grounds	N/A	N/A	N/A	N/A	N/A	Unsuitable	
Pen y Pound Stadium	Pen y Pound Stadium, Pen y Pound, Abergavenny, Monmouthshire, NP7 7RN	Property and associated grounds	N/A	N/A	N/A	N/A	N/A	Unsuitable	
Sudbrook Cricket Club	Sudbrook Cricket Club, Sandy Lane, Caldicot, Monmouthshire, NP26 5DD	Property and associated grounds	N/A	N/A	N/A	N/A	N/A	Unsuitable	Deepweir Field
Undy Pavillion & Playing Field	Undy Pavillion & Playing Field, Undy, Magor, Monmouthshire, NP26 3EN	Property and associated grounds	N/A	N/A	N/A	N/A	N/A	Unsuitable	Undy Recreation Ground
Western Avenue Playing Field	Western Avenue Playing Field, Chepstow, Monmouthshire, NP16 5RU	Property and associated grounds	N/A	N/A	N/A	N/A	N/A	Unsuitable	
Western Avenue Rugby Football Club	Western Avenue Rugby Football Club, Upton Memorial Ground, Bulwark, Chepstow, Monmouthshire, NP23 5JG	Property and associated grounds	N/A	N/A	N/A	N/A	N/A	Unsuitable	
Wyesham Recreation Ground	Wyesham Recreation Ground, Tudor Road, Wyesham, Monmouth, Monmouthshire, NP25 5DP	Property and associated grounds	N/A	N/A	N/A	N/A	N/A	Unsuitable	
Gilwern Outdoor Education Centre	Gilwern Outdoor Education Centre, Ty Mawr Lane, Gilwern, Abergavenny, Monmouthshire, NP7 6DL	Property and Land. Operational asset	N/A	N/A	N/A	N/A	N/A	Unsuitable	
Bailey Park Swimming Pool	Bailey Park Swimming Pool, Bailey Park, Abergavenny, Monmouthshire	Property. Fields in Trust.	N/A	N/A	N/A	N/A	N/A	Unsuitable	
63 Tudor Street, Land adjacent to	Tudor Street, Land adjacent to 63, Abergavenny, Monmouthshire, NP7 5DL	Public Open Space							
A4077 Crickhowell Road (2849 sq m), Land	A4077 Crickhowell Road (2849 sq m), Land, Gilwern, Abergavenny, Monmouthshire, NP7 6DL	Public Open Space							Zeals House Glaslyn Cottage
Abergavenny Castle, Land adjacent	Abergavenny Castle, Land adjacent, Mill Street, Abergavenny, Monmouthshire, NP7 6DL	Public Open Space							
Alcove Wood Open Space (1106 sqm)	Alcove Wood Open Space (1106 sqm), Bayfield, Chepstow, Monmouthshire, NP23 5JG	Public Open Space							
Alcove Wood Open Space (670.6 sqm)	Alcove Wood Open Space (670.6 sqm), Bayfield, Chepstow, Monmouthshire, NP23 5JG	Public Open Space							
Alianore Road Public Open Space	Alianore Road Public Open Space, Caldicot, Monmouthshire	Public Open Space							
Alice Crescent Public Open Space 1668 sq m	Alice Crescent Public Open Space 1668 sq m, Chepstow, Monmouthshire, NP16 5RU	Public Open Space	0.41 acres						
Apple Avenue Public Open Space	Apple Avenue Public Open Space, Undy, Caldicot, Monmouthshire, NP26 3QF	Public Open Space							
Ash Grove Public Open Space	Ash Grove Public Open Space, Caldicot, Monmouthshire, NP26 4NG	Public Open Space	Old reference prior to Merton Green Development						
Ash Tree Road Open Space	Ash Tree Road Open Space, Caerwent, Caldicot, Monmouthshire, NP26 5NU	Public Open Space							
Baker Street Open Space	Baker Street Open Space, Abergavenny, Monmouthshire, NP7 5BB	Public Open Space							Baker Gabb Garden
Barn Owl Road Open Space	Barn Owl Road Open Space, Rogiet, Caldicot, Monmouthshire, NP26 3UL	Public Open Space							
Barnets Wood Open Space (408.7sqm)	Barnets Wood Open Space (408.7sqm), Bayfield, Chepstow, Monmouthshire, NP23 5JG	Public Open Space	0.1 acres						
Barnets Wood Open Space (530.1sqm)	Barnets Wood Open Space (530.1sqm), Bayfield, Chepstow, Monmouthshire, NP23 5JG	Public Open Space	0.13 acres						
Bay Tree Lane (4505 sq m) Open Space	Bay Tree Lane (4505 sq m) Open Space, Abergavenny, Monmouthshire, NP7 5JL	Public Open Space							
Bayfield Wood Close Open Space (155.2 sqm)	Bayfield Wood Close Open Space (155.2 sqm), Bayfield, Chepstow, Monmouthshire, NP23 5JG	Public Open Space	0.03 acres						
Bayfield Wood Close Open Space (727.5 sqm)	Bayfield Wood Close Open Space (727.5 sqm), Bayfield, Chepstow, Monmouthshire, NP23 5JG	Public Open Space	0.17 acres						
Bayfield Wood playground & Open Space (6763sqm)	Bayfield Wood playground & Open Space (6763sqm), Bayfield, Chepstow, Monmouthshire, NP23 5JG	Public Open Space	1.6 acres						
Beaupreau Place Open Space	Beaupreau Place Open Space, Abergavenny, Monmouthshire, NP7 5LZ	Public Open Space							
Beaupreau Place Public Open Space	Beaupreau Place Public Open Space, Abergavenny, Monmouthshire, NP7 5LZ	Public Open Space							
Berryfield Close Open Space	Berryfield Close Open Space, Osbaston, Monmouth, Monmouthshire, NP25 3JG	Public Open Space							
Bigham Close (1233 sq m) Open Space	Bigham Close (1233 sq m) Open Space, Monmouth, Monmouthshire, NP25 5DP	Public Open Space							
Bigham Close Public Open Space	Bigham Close Public Open Space, Monmouth, Monmouthshire, NP25 5DP	Public Open Space							
Birbeck Road Open Space	Birbeck Road Open Space, Caldicot, Monmouthshire, NP26 4DX	Public Open Space							
Birch Close Open Space	Birch Close Open Space, Undy, Magor, Monmouthshire, NP26 3LW	Public Open Space							
Bishops Close (4277 sq m) Public Open Space	Bishops Close (4277 sq m) Public Open Space, Chepstow, Monmouthshire, NP16 5RU	Public Open Space	1.05 acres						
Blenheim Avenue Public Open Space	Blenheim Avenue Public Open Space, Magor, Caldicot, Monmouthshire, NP26 3NA	Public Open Space							Kensington Park
Blestium Drive Open Space	Blestium Drive Open Space, Usk, Monmouthshire	Public Open Space							
Blethyn Close Open Space	Blethyn Close Open Space, Shirenewton, Chepstow, Monmouthshire, NP16 6SW	Public Open Space							Mynydd bach
Briar Close Open Space	Briar Close Open Space, Undy, Magor, Monmouthshire, NP26 3LQ	Public Open Space							
Broadstone Terrace/Rocks Close Open Space	Broadstone Terrace/Rocks Close Open Space, Catbrook, Monmouth, Monmouthshire, NP23 5JG	Public Open Space							
Brookside Open Space	Brookside Open Space, Neddern Way, Caldicot, Monmouthshire, NP26 4NJ	Public Open Space							
Brynawr Estate, Filter Bed & Amenity Land	Brynawr Estate, Filter Bed & Amenity Land, Cwmyoy, Abergavenny, Monmouthshire, NP7 6DL	Public Open Space							
Brynteg Place Amenity Land	Brynteg Place Amenity Land, Little Mill, Pontypool, Torfaen, NP4 0HA	Public Open Space							
Budden Crescent Open Space	Budden Crescent Open Space, Caldicot, Monmouthshire, NP26 4QB	Public Open Space							
Bulwark Road Open Space	Bulwark Road Open Space, Caldicot, Monmouthshire, NP16 5JQ	Public Open Space							
Burrium Gate Open Space	Burrium Gate Open Space, Usk, Monmouthshire	Public Open Space							

Bushy Close, Land at	Bushy Close, Land at, Portskewett, Caldicot, Monmouthshire, NP26 5TR	Public Open Space					
Buzzard Close Open Space	Buzzard Close Open Space, Monmouth, Monmouthshire, NP26 3UY	Public Open Space					
Cadoc Close (110.5 sq m) Open Space	Cadoc Close (110.5 sq m) Open Space, Caerwent, Caldicot, Monmouthshire, NP26 5JG	Public Open Space					
Cadoc Close (82.74 sq m) Open Space	Cadoc Close (82.74 sq m) Open Space, Caerwent, Caldicot, Monmouthshire, NP26 5JG	Public Open Space					
Cae Derw Public Open Space (1130sqm)	Cae Derw Public Open Space (1130sqm), Gilwern, Abergavenny, Monmouthshire, NP23 5JG	Public Open Space	0.27 acres				
Cae Derw Public Open Space (701 sqm)	Cae Derw Public Open Space (701 sqm), Gilwern, Abergavenny, Monmouthshire, NP23 5JG	Public Open Space	0.17 acres				
Cae Melin (1104 sq m) Open Space	Cae Melin (1104 sq m) Open Space, Little Mill, Pontypool, NP4 0HX	Public Open Space	0.27 acres				
Cae-pen-y-dre Close, Land at	Cae-pen-y-dre Close, Land at, Abergavenny, Monmouthshire, NP7 5UR	Public Open Space					
Caerwent Lane (3615 sq m) Public Open Space	Caerwent Lane (3615 sq m) Public Open Space, Chepstow, Monmouthshire, NP13 5JG	Public Open Space	0.89 acres				
Caerwent Lane (69.22 sqm) Open Space	Caerwent Lane (69.22sqm) Open Space, Thornwell, Chepstow, Monmouthshire, NP13 5JG	Public Open Space	0.01 acres				
Caldicot Levels, Land forming part of	Caldicot Levels, Land forming part of, Sudbrook, Caldicot, Monmouthshire, NP26 5JG	Public Open Space					
Cappers Place Amenity Land	Cappers Place Amenity Land, Monmouth, Monmouthshire, NP25 5AL	Public Open Space					
Cassia Drive Open Space	Cassia Drive Open Space, Usk, Monmouthshire	Public Open Space					
Castle Wood Open Space (678.1sqm)	Castle Wood Open Space (678.1sqm), Bayfield, Chepstow, Monmouthshire, NP13 5JG	Public Open Space	0.16 acres				
Castle Meadows, Land at	Castle Meadows, Land at, Abergavenny, Monmouthshire, NP7 7RZ	Public Open Space					
Castle Oak (1154 sq m) Open Space	Castle Oak (1154 sq m) Open Space, Usk, Monmouthshire, NP15 1SG	Public Open Space					
Castle Oak (842.9 sq m) Open Space	Castle Oak (842.9 sq m) Open Space, Usk, Monmouthshire, NP15 1SG	Public Open Space					
Caxton Court Public Open Space	Caxton Court Public Open Space, Monmouth, Monmouthshire, NP25 5DJ	Public Open Space					
Charles Edwards Close (661.4 sq m) Open Space	Charles Edwards Close (661.4 sq m) Open Space, Llanfoist, Abergavenny, Monmouthshire, NP23 5JG	Public Open Space					
Chaucer Way Public Open Space	Chaucer Way Public Open Space, Osbaston, Monmouth, Monmouthshire, NP25 5JG	Public Open Space					
Chepstow Road Open Space	Chepstow Road Open Space, Trellech, Monmouth, Monmouthshire, NP25 4PE	Public Open Space	B4293				
Chestnut Close open Space	Chestnut Close open Space, Magor, Caldicot, Monmouthshire, NP7 5JZ	Public Open Space					
Chestnut Drive (1270 sq m) Open Space	Chestnut Drive (1270 sq m) Open Space, Rogiet, Caldicot, Monmouthshire, NP7 5JZ	Public Open Space					
Chestnut Drive (1423 sq m) Open Space	Chestnut Drive (1423 sq m) Open Space, Abergavenny, Monmouthshire, NP7 5JZ	Public Open Space					
Chestnut Drive (180 sq m) Open Space	Chestnut Drive (180 sq m) Open Space, Rogiet, Caldicot, Monmouthshire, NP7 5JZ	Public Open Space					
Chestnut Drive (268.2 sq m) Open Space	Chestnut Drive (268.2 sq m) Open Space, Rogiet, Caldicot, Monmouthshire, NP7 5JZ	Public Open Space					
Chestnut Drive (703 sq m) Open Space	Chestnut Drive (703 sq m) Open Space, Rogiet, Caldicot, Monmouthshire, NP7 5JZ	Public Open Space					
Church Rise Public Open Space	Church Rise Public Open Space, Undy, Caldicot, Monmouthshire, NP26 3NR	Public Open Space					
Church Road Public Open Space	Church Road Public Open Space, Church Road, Caldicot, Monmouthshire	Public Open Space					
Churchmead Open Space	Churchmead Open Space, Rogiet, Caldicot, Monmouthshire, NP26 3TG	Public Open Space					
Cinderhill Street Amenity Land	Cinderhill Street Amenity Land, Monmouth, Monmouthshire, NP25 5EY	Public Open Space					
Clearview Court (103.2 sq m) Public Open Space	Clearview Court (103.2 sq m) Public Open Space, Shirenewton, Chepstow, Monmouthshire, NP23 5JG	Public Open Space	0.02				
Clearview Court (129.2 sq m) Public Open Space	Clearview Court (129.2 sq m) Public Open Space, Shirenewton, Chepstow, Monmouthshire, NP23 5JG	Public Open Space	0.03				
Clearview Court (14.09 sq m) Public Open Space	Clearview Court (14.09 sq m) Public Open Space, Shirenewton, Chepstow, Monmouthshire, NP23 5JG	Public Open Space	0.003				
Clearview Court (275.3 sq m) Public Open Space	Clearview Court (275.3 sq m) Public Open Space, Shirenewton, Chepstow, Monmouthshire, NP23 5JG	Public Open Space	0.06				
Clearview Court (321.9 sq m) Public Open Space	Clearview Court (321.9 sq m) Public Open Space, Shirenewton, Chepstow, Monmouthshire, NP23 5JG	Public Open Space	0.07				
Clearview Court (36.49 sq m) Public Open Space	Clearview Court (36.49 sq m) Public Open Space, Shirenewton, Chepstow, Monmouthshire, NP23 5JG	Public Open Space	0.008				
Clearview Court (39.31 sq m) Public Open Space	Clearview Court (39.31 sq m) Public Open Space, Shirenewton, Chepstow, Monmouthshire, NP23 5JG	Public Open Space	0.009				
Clearview Court (42.03 sq m) Public Open Space	Clearview Court (42.03 sq m) Public Open Space, Shirenewton, Chepstow, Monmouthshire, NP23 5JG	Public Open Space	0.009				
Clearview Court (204.7 sq m) Public Open Space	Clearview Court (204.7 sq m) Public Open Space, Shirenewton, Chepstow, Monmouthshire, NP23 5JG	Public Open Space	0.05				
Clos Alwen Public Open Space & Playground	Clos Alwen Public Open Space & Playground, Clos Alwen, Caldicot, Monmouthshire	Public Open Space					
Clos Croeso Amenity Land	Clos Croeso Amenity Land, Usk, Monmouthshire, NP15 1AZ	Public Open Space					
Clos Rheidol Public Open Space	Clos Rheidol Public Open Space, Caldicot, Monmouthshire, NP26 4JD	Public Open Space					St Marys Meadow
Clos Rheidol Public Open Space (4 parcels)	Clos Rheidol Open Space (4 parcels), Clos Rheidol, Caldicot, Monmouthshire	Public Open Space					
Clydach Villa, Land adjacent to	Clydach Villa, Land adjacent to, Church Road, Clydach, Abergavenny, Monmouthshire, NP23 5JG	Public Open Space					
Cobb Crescent Public Open Space	Cobb Crescent Public Open Space, Caldicot, Monmouthshire, NP26 5BY	Public Open Space					
Conigar Crescent Open Space	Conigar Crescent Open Space, Usk, Monmouthshire, NP15 1AZ	Public Open Space					
Cornford Close Public Open Space	Cornford Close Public Open Space, Osbaston, Monmouth, Monmouthshire, NP25 5JG	Public Open Space					
Cornpoppy Avenue (269.9 sq m) Open Space	Cornpoppy Avenue (269.9 sq m) Open Space, Monmouth, Monmouthshire, NP25 5JG	Public Open Space					
Cornwallis Way Public Open Space	Cornwallis Way Public Open Space, Monmouth, Monmouthshire, NP25 5DN	Public Open Space					
Courtfield Close (117.9 sq m) Open Space	Courtfield Close (117.9 sq m) Open Space, Monmouth, Monmouthshire, NP25 5EY	Public Open Space					
Courthouse Road Public Open Space	Courthouse Road Public Open Space, Llanvair Discoed, Chepstow, Monmouthshire, NP23 5JG	Public Open Space					
Cowleaze Open space	Cowleaze Open space, Magor, Monmouthshire, NP26 3LE	Public Open Space					
Cresta Road (153.8 sq m) Open Space	Cresta Road (153.8 sq m) Open Space, Abergavenny, Monmouthshire, NP7 7AU	Public Open Space	0.03				
Cresta Road (321.5 sq m) Open Space	Cresta Road (321.5 sq m) Open Space, Abergavenny, Monmouthshire, NP7 7AU	Public Open Space	0.07				
Croesonen Gardens Open Space (104sqm)	Croesonen Gardens Open Space (104sqm), Abergavenny, Monmouthshire, NP7 7AU	Public Open Space	0.02				
Croesonen Gardens Open Space (571sqm)	Croesonen Gardens Open Space (571sqm), Abergavenny, Monmouthshire, NP7 7AU	Public Open Space	0.141				
Croesonen Parc Public Open Space	Croesonen Parc Public Open Space, Abergavenny, Monmouthshire, NP7 6PF	Public Open Space					
Croesonnen Cottages, Land adjacent to	Croesonnen Cottages, Land adjacent to, Abergavenny, Monmouthshire, NP7 6BJ	Public Open Space					
Cybi Avenue Open Space	Cybi Avenue Open Space, Llangybi, Usk, Monmouthshire, NP15 1TU	Public Open Space					
Cybi Drive Open Space	Cybi Drive Open Space, Llangybi, Usk, Monmouthshire, NP15 1TU	Public Open Space					
Cybi Rise Open Space	Cybi Rise Open Space, Llangybi, Usk, Monmouthshire, NP15 1TU	Public Open Space					
De Cantelupe Close Open Space	De Cantelupe Close Open Space, Abergavenny, Monmouthshire, NP7 9JB	Public Open Space					
Deans Hill Open Space	Deans Hill Open Space, Chepstow, Monmouthshire, NP16 5AT	Public Open Space					
Deepweir Open Space (189.3 sq m)	Deepweir Open Space (189.3 sq m), Caldicot, Monmouthshire, NP26 5JG	Public Open Space					
Deepweir Open Space (27.07) sq m	Deepweir Open Space (27.07) sq m, Caldicot, Monmouthshire, NP26 5JG	Public Open Space					
Deepweir Open Space 137.5 sq m	Deepweir Open Space 137.5 sq m, Caldicot, Monmouthshire, NP26 5JG	Public Open Space					
Deepweir Open Space 184.1sq m	Deepweir Open Space 184.1sq m, Caldicot, Monmouthshire, NP26 5JG	Public Open Space					
Deepweir Open Space 75.32 sq m	Deepweir Open Space 75.32 sq m, Caldicot, Monmouthshire, NP26 5JG	Public Open Space					
Delafield Road (2007 sq m) Open Space	Delafield Road (2007 sq m) Open Space, Abergavenny, Monmouthshire, NP7 7AU	Public Open Space	0.49				
Delafield Road (2803 sq m) Open Space	Delafield Road (2803 sq m) Open Space, Abergavenny, Monmouthshire, NP7 7AU	Public Open Space	0.69				
Delafield Road (47.01sq m) Open Space	Delafield Road (47.01sq m) Open Space, Abergavenny, Monmouthshire, NP7 7AU	Public Open Space	0.01				

Deri View Open Space	Deri View Open Space, Charles Close, Abergavenny, Monmouthshire, NP7 6AX	Public Open Space					
Derwen Way Open Space	Derwen Way Open Space, Abergavenny, Monmouthshire, NP7 6BP	Public Open Space					
Drybridge Park Open Space	Drybridge Park Open Space, Monmouth, Monmouthshire, NP25 5AS	Public Open Space					
Dunlin Avenue Public Open Space	Dunlin Avenue Public Open Space, Caldicot, Monmouthshire, NP26 5DL	Public Open Space					
Elan Way (26.65 sq m) Open Space	Elan Way (26.65 sq m) Open Space, Caldicot, Monmouthshire, NP26 4PZ	Public Open Space					
Elan Way (303.4 sq m) Open Space	Elan Way (303.4 sq m) Open Space, Caldicot, Monmouthshire, NP26 4PZ	Public Open Space					
Elan Way (334.3 sq m) Open Space	Elan Way (334.3 sq m) Open Space, Caldicot, Monmouthshire, NP26 4PZ	Public Open Space					
Elan Way (45.9 sq m) Open Space	Elan Way (45.9 sq m) Open Space, Caldicot, Monmouthshire, NP26 4PZ	Public Open Space					
Elan Way (6.386 sq m) Open Space	Elan Way (6.386 sq m) Open Space, Caldicot, Monmouthshire, NP26 4PZ	Public Open Space					
Elan Way (81.81 sq m) Open Space	Elan Way (81.81 sq m) Open Space, Caldicot, Monmouthshire, NP26 4PZ	Public Open Space					
Elstob Way (196.5 sq m) Open Space	Elstob Way (196.5 sq m) Open Space, Monmouth, Monmouthshire, NP25 5ET	Public Open Space					
Elstob Way (228.3 sq m) Open Space	Elstob Way (228.3 sq m) Open Space, Monmouth, Monmouthshire, NP25 5ET	Public Open Space					
Elstob Way (285.6 sq m) Open Space	Elstob Way (285.6 sq m) Open Space, Monmouth, Monmouthshire, NP25 5ET	Public Open Space					
Elstob Way (370.2 sq m) Open Space	Elstob Way (370.2 sq m) Open Space, Monmouth, Monmouthshire, NP25 5ET	Public Open Space					
Elstob Way (375.4 sq m) Open Space	Elstob Way (375.4 sq m) Open Space, Monmouth, Monmouthshire, NP25 5ET	Public Open Space					
Elstob Way (58.13 sq m) Open Space	Elstob Way (58.13 sq m) Open Space, Monmouth, Monmouthshire, NP25 5ET	Public Open Space					
Elstob Way (strip) Open Space	Elstob Way (strip) Open Space, Monmouth, Monmouthshire, NP25 5ET	Public Open Space					
Ethley Drive (5608 sq m) Open Space	Ethley Drive (5608 sq m) Open Space, Raglan, Usk, Monmouthshire, NP26 2FB	Public Open Space					
Fedw Wood Open Space (3977sqm)	Fedw Wood Open Space (3977sqm), Bayfield, Chepstow, Monmouthshire, NP16	Public Open Space	0.98				
Ferney Cross Public Open Space	Ferney Cross Public Open Space, Longfellow Road, Caldicot, Monmouthshire, NP	Public Open Space					
Fitzroy Close Open Space (Clawddu)	Fitzroy Close Open Space (Clawddu), Monmouth, Monmouthshire, NP25 5BJ	Public Open Space					
Forest Hill Open Space	Forest Hill Open Space, Gilwern, Abergavenny, Monmouthshire, NP7 0DY	Public Open Space					
Forest View Amenity Land	Forest View Amenity Land, The Narth, Monmouth, Monmouthshire, NP25 4QQ	Public Open Space					
Former Railway Usk, Land comprising 7 parcels	Former Railway Usk, Land comprising 7 parcels, Usk, Monmouthshire, NP15	Public Open Space					
Fountain Way (1478 sq m) Public Open Space	Fountain Way (1478 sq m) Public Open Space, Chepstow, Monmouthshire, NP16	Public Open Space	0.365				
Garthi Close Open Space	Garthi Close Open Space, Mitchel Troy, Monmouth, Monmouthshire, NP25 4JN	Public Open Space					
Garvey Close (158.5 sq m) Public Open Space	Garvey Close (158.5 sq m) Public Open Space, Chepstow, Monmouthshire, NP16	Public Open Space					
Garvey Close (296.5 sq m) Public Open Space	Garvey Close (296.5 sq m) Public Open Space, Chepstow, Monmouthshire, NP16	Public Open Space					
Geoffrey Drive Open Space	Geoffrey Drive Open Space, Monmouth, Monmouthshire, NP25 5TR	Public Open Space					
Gethin Place Amenity Land	Gethin Place Amenity Land, Llanfair Kilgeddin, Abergavenny, Monmouthshire, NP	Public Open Space					
Glan Gavenny Open Space	Glan Gavenny Open Space, Abergavenny, Monmouthshire, NP7 6NQ	Public Open Space					
Goldwire Lane Amenity Land	Goldwire Lane Amenity Land, Monmouth, Monmouthshire, NP25 5AL	Public Open Space					
Goldwire Lane Open Space	Goldwire Lane Open Space, Monmouth, Monmouthshire, NP25 5AQ	Public Open Space					
Granville Street, Land at	Granville Street, Land at, Monmouth, Monmouthshire, NP25 3DR	Public Open Space					
Green Moor Lane Public Open Space	Green Moor Lane Public Open Space, Magor, Caldicot, Monmouthshire, NP26 3N	Public Open Space					Kensington Park
Greenlands Close Public Open Space	Greenlands Close Public Open Space, Wyesham, Monmouth, Monmouthshire, NP	Public Open Space					
Greenmeadow Crescent Public Open Space	Greenmeadow Crescent Public Open Space, Little Mill, Usk, Monmouthshire	Public Open Space					
Grosmont Close (4691 sq m) Open Space	Grosmont Close (4691 sq m) Open Space, Monmouth, Monmouthshire, NP25 5U	Public Open Space					
Hadnock Road & River Wye, Land between	Hadnock Road & River Wye, Land between, Monmouth, Monmouthshire, NP25	Public Open Space					
Hamilton Way Open Space (1244sqm)	Hamilton Way Open Space (1244sqm), Monmouth, Monmouthshire, NP25 5BY	Public Open Space	0.3				
Hastings Close Open Space	Hastings Close Open Space, Abergavenny, Monmouthshire, NP7 9JD	Public Open Space					
Hawthorn Close (264.3 sq m) Open Space	Hawthorn Close (264.3 sq m) Open Space, Chepstow, Monmouthshire, NP16 5R	Public Open Space					
Heol Sirhowy Open Space	Heol Sirhowy Open Space, Heol Sirhowy, Caldicot	Public Open Space					
Heol Teifi Public Open Space & Playground (2 parcels)	Heol Teifi Open Space & Playground (2 parcels) 15540sqm, Caldicot, Monmouths	Public Open Space	3.8				
Heol Teifi Public Open Space & Playground (2 parcels)	Heol Teifi Public Open Space & Playground (2 parcels) 882.3 sqm, Heol Teifi, Cal	Public Open Space	0.21				
Heol Towy Public Open Space & Playground	Heol Towy Public Open Space & Playground, Heol Towy, Caldicot, Monmouthshir	Public Open Space					
High Beech Lane Open Space	High Beech Lane Open Space, Chepstow, Monmouthshire, NP16 5BQ	Public Open Space					
Highfield Amenity Land	Highfield Amenity Land, Goytre, Abergavenny, Monmouthshire, NP4 0AQ	Public Open Space					
Highfield Communal Area	Highfield Communal Area, Goetre, Abergavenny, Monmouthshire, NP4 0BH	Public Open Space					
Highmeadow Open Space	Highmeadow Open Space, Wyesham, Monmouth, Monmouthshire, NP25 3TB	Public Open Space					
Hill Barn View Open Space	Hill Barn View Open Space, Portskewett, Caldicot, Monmouthshire, NP26 5SE	Public Open Space	0.32 acres	Station Road	Inside development boundary		
Holly Close (126.5 sq m) Open Space	Holly Close (126.5 sq m) Open Space, Chepstow, Monmouthshire, NP16 5RP	Public Open Space					
Holly Close (28.16 sq m) Open Space	Holly Close (28.16 sq m) Open Space, Chepstow, Monmouthshire, NP16 5RP	Public Open Space					
Holly Close (34.86 sq m) Open Space	Holly Close (34.86 sq m) Open Space, Chepstow, Monmouthshire, NP16 5RP	Public Open Space					
Holly Close (445.8 sq m) Open Space	Holly Close (445.8 sq m) Open Space, Chepstow, Monmouthshire, NP16 5RP	Public Open Space					
Holywell Close (376.2 sq m) Open Space	Holywell Close (376.2 sq m) Open Space, Monmouth, Monmouthshire, NP25 5E	Public Open Space					
Holywell Close (423.5 sq m) Open Space	Holywell Close (423.5 sq m) Open Space, Monmouth, Monmouthshire, NP25 5E	Public Open Space					
Holywell Crescent Open Space	Holywell Crescent Open Space, Abergavenny, Monmouthshire, NP7 5LG	Public Open Space					
Jordans Way Public Open Space	Jordans Way Public Open Space, Monmouth, Monmouthshire, NP25 5EA	Public Open Space					
Kemeys Road Amenity Land & Sewerage Works	Kemeys Road Amenity Land & Sewerage Works, Llanccay, Usk, Monmouthshire,	Public Open Space					
Kemys Craig Wood, Land at	Kemys Craig Wood, Land at, Llantrisant, Usk, Monmouthshire	Public Open Space					
Kensington Park (415 sq m) Public Open Space	Kensington Park (415 sq m) Public Open Space, Magor, Caldicot, Monmouthshire	Public Open Space	0.1				
Kensington Park (729 sq m) Public Open Space	Kensington Park (729 sq m) Public Open Space, Magor, Caldicot, Monmouthshire	Public Open Space	0.18				
Kings Fee Open Space	Kings Fee Open Space, Monmouth, Monmouthshire, NP25 5BW	Public Open Space					
Kingsmark Lane (222 sq m) Public Open Space	Kingsmark Lane (222 sq m) Public Open Space, Chepstow, Monmouthshire, NP1	Public Open Space	0.05				
Kingsmark Lane (242 sq m) Public Open Space	Kingsmark Lane (242 sq m) Public Open Space, Chepstow, Monmouthshire, NP1	Public Open Space	0.06				
Laburnam Way (113.1 sq m) Open Space	Laburnam Way (113.1 sq m) Open Space, Chepstow, Monmouthshire, NP16 5RF	Public Open Space					
Laburnam Way (521.6 sq m) Open Space	Laburnam Way (521.6 sq m) Open Space, Chepstow, Monmouthshire, NP16 5RF	Public Open Space					
Lancaster Way Public Open Space	Lancaster Way Public Open Space, Osbaston, Monmouth, Monmouthshire, NP25	Public Open Space					
Landau Close (136.8) Open Space	Landau Close (136.8) Open Space, Undy, Magor, Monmouthshire, NP26 3NT	Public Open Space					
Landau Close (351.7) Open Space	Landau Close (351.7) Open Space, Undy, Magor, Monmouthshire, NP26 3NT	Public Open Space					
Lapwing Avenue Open Space	Lapwing Avenue Open Space, Undy, Magor, Monmouthshire, NP26 5RN	Public Open Space					

Laurel Close Open Space	Laurel Close Open Space, Undy, Magor, Monmouthshire, NP26 3NP	Public Open Space							
Laurel Close Open Space	Laurel Close Open Space, Undy, Magor, Monmouthshire, NP26 3NP	Public Open Space							
Levitsfield Close Open Space (1255sqm)	Levitsfield Close Open Space (1255sqm), Monmouth, Monmouthshire, NP25 5BZ	Public Open Space	0.31						
Levitsfield Close Public Open Space	Levitsfield Close Public Open Space, Monmouth, Monmouthshire, NP25 5BZ	Public Open Space							
Limetree Avenue Amenity Land	Limetree Avenue Amenity Land, Wyesham, Monmouth, Monmouthshire, NP25 3L	Public Open Space							
Linnet Road Public Open Space	Linnet Road Public Open Space, Caldicot, Monmouthshire, NP26 5DJ	Public Open Space							
Llanellen Road Amenity Land	Llanellen Road Amenity Land, Llanfoist, Abergavenny, Monmouthshire, NP7 9LY	Public Open Space							
Llanvair Road Open Space	Llanvair Road Open Space, Caerwent, Caldicot, Monmouthshire, NP26 5NY	Public Open Space							
LLwyn Melin Open Space	LLwyn Melin Open Space, Clydach, Abergavenny, Monmouthshire, NP7 0LJ	Public Open Space							
Longfellow Close Public Open Space	Longfellow Close Public Open Space, Caldicot, Monmouthshire, NP26 4LD	Public Open Space							
Maesy Llawydd ( 1086sqm) Open Space	Maesy Llawydd ( 1086sqm) Open Space, Abergavenny, Monmouthshire, NP7 5L	Public Open Space							Larchfield House
Maesy Llawydd ( 653.4sqm) Open Space	Maesy Llawydd ( 653.4sqm) Open Space, Abergavenny, Monmouthshire, NP7 5L	Public Open Space							Larchfield House
Main Road (264.9 sq m) Open Space	Main Road (264.9 sq m) Open Space, Magor, Caldicot, Monmouthshire, NP26 3H	Public Open Space							
Manor Wood Open Space (259.6 sqm)	Manor Wood Open Space (259.6 sqm), Bayfield, Chepstow, Monmouthshire, NP16 5RG	Public Open Space							
Manson Heights Amenity Land	Manson Heights Amenity Land, Monmouth, Monmouthshire, NP25 5QX	Public Open Space							
Maple Avenue (109.3 sq m) Open Space	Maple Avenue (109.3 sq m) Open Space, Chepstow, Monmouthshire, NP16 5RG	Public Open Space							
Maple Avenue (120.1 sq m) Open Space	Maple Avenue (120.1 sq m) Open Space, Chepstow, Monmouthshire, NP16 5RG	Public Open Space							
Maple Avenue (171.6 sq m) Open Space	Maple Avenue (171.6 sq m) Open Space, Chepstow, Monmouthshire, NP16 5RG	Public Open Space							
Maple Avenue (56.64 sq m) Open Space	Maple Avenue (56.64 sq m) Open Space, Chepstow, Monmouthshire, NP16 5RG	Public Open Space							
Maple Avenue (674.1 sq m) Open Space	Maple Avenue (674.1 sq m) Open Space, Chepstow, Monmouthshire, NP16 5RG	Public Open Space							
Martin Close Open Space	Martin Close Open Space, Rogiet, Caldicot, Monmouthshire, NP26 3UG	Public Open Space							
Mary De Bohun Close (708.6 sq m) Open Space	Mary De Bohun Close (708.6 sq m) Open Space, Monmouth, Monmouthshire, NP25 5BZ	Public Open Space							
Mayfield Lodge, Land adjacent	Mayfield Lodge, Land adjacent, Usk, Monmouthshire, NP15 5JH	Public Open Space							
Meadow Rise (115.1 sq m) Open Space	Meadow Rise (115.1 sq m) Open Space, Undy, Magor, Monmouthshire, NP26 3J	Public Open Space							
Meadow Rise (132.1 sq m) Open Space	Meadow Rise (132.1 sq m) Open Space, Undy, Magor, Monmouthshire, NP26 3J	Public Open Space							
Merlin Close Open Space	Merlin Close Open Space, Monmouth, Monmouthshire, NP26 3UX	Public Open Space							
Mill Common Open Space	Mill Common Open Space, Magor, Caldicot, Monmouthshire, NP26 3JH	Public Open Space							
Mill Reen ( 564 sq m) Open Space	Mill Reen ( 564 sq m) Open Space, Magor, Caldicot, Monmouthshire, NP26 3JP	Public Open Space							
Mill Reen (425.6 sq m) Open Space	Mill Reen (425.6 sq m) Open Space, Magor, Caldicot, Monmouthshire, NP26 3JP	Public Open Space							
Millfield Park Open Space	Millfield Park Open Space, Magor, Caldicot, Monmouthshire, NP26 3LF	Public Open Space							
Mount Pleasant Open Space	Mount Pleasant Open Space, Main Road, Clydach, Abergavenny, Monmouthshire, NP26 5JH	Public Open Space							
Mounton Close Open Space	Mounton Close Open Space, Chepstow, Monmouthshire, NP16 5EG	Public Open Space							
Mounton Drive Open Space	Mounton Drive Open Space, Chepstow, Monmouthshire, NP16 5EH	Public Open Space							
Nedderm Court Open Space(East)	Nedderm Court Open Space(East), Nedderm Way, Caldicot, Monmouthshire, NP26 3JH	Public Open Space							
Nedderm Court Open Space(West)	Nedderm Court Open Space(West), Nedderm Way, Caldicot, Monmouthshire, NP26 3JH	Public Open Space							
Newport Road Public Open Space	Newport Road Public Open Space, Adj Westfield, Caldicot, Monmouthshire, NP26 3JH	Public Open Space							
Nightingale Close Public Open Space	Nightingale Close Public Open Space, Caldicot, Monmouthshire, NP26 5ES	Public Open Space							
Normandy Way Public Open Space	Normandy Way Public Open Space, Chepstow, Monmouthshire, NP16 5NB	Public Open Space							
North East of Pwll Bach ( off A449), Land	North East of Pwll Bach ( off A449), Land, Llantrisant, Usk, Monmouthshire, NP23 5JH	Public Open Space							
North of Newbridge on Usk Picnic site (off A449), Land	North of Newbridge on Usk Picnic site (off A449), Land, Llantrisant, Usk, Monmouthshire, NP23 5JH	Public Open Space							
Oak Close Open Space	Oak Close Open Space, Undy, Magor, Monmouthshire, NP26 3LR	Public Open Space							
Oak Grove Open Space	Oak Grove Open Space, Rockfield, Monmouth, Monmouthshire, NP25 5PY	Public Open Space							
Oaklands Drive (11030 sq m) Open Space	Oaklands Drive (11030 sq m) Open Space, Monmouth, Monmouthshire, NP25 5EG	Public Open Space							
Oaklands Drive (274.1sqm) Public Open Space	Oaklands Drive (274.1sqm) Public Open Space, Monmouth, Monmouthshire, NP25 5EG	Public Open Space							
Oakley Way, Land at rear	Oakley Way, Land at rear, Caldicot, Monmouthshire, NP26 4EA	Public Open Space							
Orchard Close Amenity Land	Orchard Close Amenity Land, Skenfrith, Abergavenny, Monmouthshire, NP7 8UG	Public Open Space							
Orchid Drive Open Space	Orchid Drive Open Space, Undy, Magor, Monmouthshire, NP26 5GE	Public Open Space							
Osprey Drive Open Space	Osprey Drive Open Space, Undy, Magor, Monmouthshire, NP26 5RL	Public Open Space							
Park Crescent & Hereford Road Open Space	Park Crescent & Hereford Road Open Space, Abergavenny, Lansdown, NP7 5TN	Public Open Space							
Park Crescent Open Space	Park Crescent Open Space, Abergavenny, Monmouthshire, NP7 5TN	Public Open Space							
Pembroke Court Open space	Pembroke Court Open space, Undy, Caldicot, Monmouthshire, NP26 3QD	Public Open Space							
Pennyfarthing Lane Open Space	Pennyfarthing Lane Open Space, Undy, Magor, Monmouthshire, NP26 3NU	Public Open Space							
Penterry Park (15940 sq m) Open Space	Penterry Park (15940 sq m) Open Space, Chepstow, Monmouthshire, NP16 5AZ	Public Open Space							
Penterry Park (383 sq m) Open Space	Penterry Park (383 sq m) Open Space, Chepstow, Monmouthshire, NP16 5AZ	Public Open Space							
Phoenix Drive (329.3 sq m) Open Space	Phoenix Drive (329.3 sq m) Open Space, Chepstow, Monmouthshire, NP16 5TJ	Public Open Space							
Plas Mynydd Open Space	Plas Mynydd Open Space, Llanfoist, Abergavenny, Monmouthshire, NP7 9FJ	Public Open Space							
Plover Crescent Open Space	Plover Crescent Open Space, Undy, Magor, Monmouthshire, NP26 5ET	Public Open Space							
Poorscript Lane Amenity Land	Poorscript Lane Amenity Land, Grosmont, Abergavenny, Monmouthshire, NP7 8L	Public Open Space							
Poplar Close (376.7 sq m) Open Space	Poplar Close (376.7 sq m) Open Space, Rogiet, Caldicot, Monmouthshire, NP26 3JH	Public Open Space							
Poplar Close (91.75 sq m) Open Space	Poplar Close (91.75 sq m) Open Space, Rogiet, Caldicot, Monmouthshire, NP26 3JH	Public Open Space							
Port Mahon Close (111.4 sq m) Open Space	Port Mahon Close (111.4 sq m) Open Space, Monmouth, Monmouthshire, NP25 5EG	Public Open Space							
Port Mahon Close (57.99 sq m) Open Space	Port Mahon Close (57.99 sq m) Open Space, Monmouth, Monmouthshire, NP25 5EG	Public Open Space							
Port Mahon Close (88.51 sq m) Open Space	Port Mahon Close (88.51 sq m) Open Space, Monmouth, Monmouthshire, NP25 5EG	Public Open Space							
Prince Charles Road (299.2 sq m) Open Space	Prince Charles Road (299.2 sq m) Open Space, Raglan, Usk, Monmouthshire, NP23 5JH	Public Open Space							
Prince Charles Road Open Space	Prince Charles Road Open Space, Raglan, Monmouthshire, NP15 2FB	Public Open Space							
Priory Close Public Open Space	Priory Close Public Open Space, Chepstow, Monmouthshire, NP16 5ND	Public Open Space							
Quarry Rise Open Space	Quarry Rise Open Space, Undy, Magor, Monmouthshire, NP25 3JU	Public Open Space							Dancing Hill
Reade Street Open Space	Reade Street Open Space, Wyesham, Monmouth, Monmouthshire, NP25 3TJ	Public Open Space							
Redbrook Road Amenity Land	Redbrook Road Amenity Land, Wyesham, Monmouth, Monmouthshire, NP25 3TJ	Public Open Space							
Rhyd y Meirch Open Space	Rhyd y Meirch Open Space, Llanover, Abergavenny, Monmouthshire, NP7 9EU	Public Open Space							
River View (289.7 sq m) Open Space	River View (289.7 sq m) Open Space, Chepstow, Monmouthshire, NP16 5AX	Public Open Space							
River View (331.5 sq m) Open Space	River View (331.5 sq m) Open Space, Chepstow, Monmouthshire, NP16 5AX	Public Open Space							



River View (560.9 sq m) Open Space	River View (560.9 sq m) Open Space, Chepstow, Monmouthshire, NP16 5AX	Public Open Space						
Rockfield Grove (1022 sq m) Open Space	Rockfield Grove (1022 sq m) Open Space, Undy, Caldicot, Monmouthshire, NP26 3FD	Public Open Space						
Rockfield Grove (483.6 sq m) Open Space	Rockfield Grove (483.6 sq m) Open Space, Undy, Caldicot, Monmouthshire, NP26 3FD	Public Open Space						
Rockfield View Open Space	Rockfield View Open Space, Undy, Magor, Monmouthshire, NP26 3FD	Public Open Space						Rockfield Grove
Rockfield Way Open Space	Rockfield Way Open Space, Undy, Magor, Monmouthshire, NP26 3FD	Public Open Space						Rockfield Grove
Rocklea Open Space	Rocklea Open Space, Mitchell Troy, Monmouth, Monmouthshire, NP25 4JE	Public Open Space						
Rogiet Primary, Land adjacent (14384.1 sqm)	Rogiet Primary, Land adjacent, Station Road, Rogiet, Monmouthshire, NP26 3SD	Public Open Space						
Rolls Avenue Open Space	Rolls Avenue Open Space, Monmouth, Monmouthshire, NP25 5AY	Public Open Space						
Ross Road (9085 sq m) Open Space	Ross Road (9085 sq m) Open Space, Abergavenny, Monmouthshire, NP7 5LT	Public Open Space						
Rowan Drive (111.3 sq m) Open Space	Rowan Drive (111.3 sq m) Open Space, Chepstow, Monmouthshire, NP16 5RQ	Public Open Space						
Rowan Drive (132.8 sq m) Open Space	Rowan Drive (132.8 sq m) Open Space, Chepstow, Monmouthshire, NP16 5RQ	Public Open Space						
Rowan Drive (153.3 sq m) Open Space	Rowan Drive (153.3 sq m) Open Space, Chepstow, Monmouthshire, NP16 5RQ	Public Open Space						
Rowan Drive (26.91 sq m) Open Space	Rowan Drive (26.91 sq m) Open Space, Chepstow, Monmouthshire, NP16 5RQ	Public Open Space						
Rowan Drive (46.6 sq m) Open Space	Rowan Drive (46.6 sq m) Open Space, Chepstow, Monmouthshire, NP16 5RQ	Public Open Space						
Rowan Drive (911.3 sq m) Open Space	Rowan Drive (911.3 sq m) Open Space, Chepstow, Monmouthshire, NP16 5RQ	Public Open Space						
Rowing Club, Land adjacent	Rowing Club, Land adjacent, Monmouth, Monmouthshire, NP25 3DP	Public Open Space						A40 Wye Bridge
Rushey Meadow Open Space (7518sqm)	Rushey Meadow Open Space (7518sqm), Monmouth, Monmouthshire, NP25 5BT	Public Open Space						
Rushey Meadow Public Open Space	Rushey Meadow Public Open Space, Monmouth, Monmouthshire, NP25 5BT	Public Open Space						
Samuel Rodgers Crescent (155.8sqm) Open Space	Samuel Rodgers Crescent (155.8sqm) Open Space, Thornwell, Chepstow, Monmouthshire, NP25 5BT	Public Open Space	0.03					
Samuel Rodgers Crescent (162.8sqm) Open Space	Samuel Rodgers Crescent (162.8sqm) Open Space, Thornwell, Chepstow, Monmouthshire, NP25 5BT	Public Open Space	0.04					
Samuel Salter Close (342.3 sq m) Open Space	Samuel Salter Close (342.3 sq m) Open Space, Llanfoist, Abergavenny, Monmouthshire, NP23 5LW	Public Open Space						
Sarno Square (170705 sq m) Open Space	Sarno Square (170705 sq m) Open Space, Abergavenny, Monmouthshire, NP7 5LW	Public Open Space						
School Hill (153.6 sq m) Open Space	School Hill (153.6 sq m) Open Space, Chepstow, Monmouthshire, NP16 5BZ	Public Open Space						
School Hill (30.10 sq m) Open Space	School Hill (30.10 sq m) Open Space, Chepstow, Monmouthshire, NP16 5BZ	Public Open Space						
School Hill (368.3 sq m) Open Space	School Hill (368.3 sq m) Open Space, Chepstow, Monmouthshire, NP16 5BZ	Public Open Space						
School Hill (399.5 sq m) Open Space	School Hill (399.5 sq m) Open Space, Chepstow, Monmouthshire, NP16 5BZ	Public Open Space						
School Hill (40.98 sq m) Open Space	School Hill (40.98 sq m) Open Space, Chepstow, Monmouthshire, NP16 5BZ	Public Open Space						
School Hill (8.743 sq m) Open Space	School Hill (8.743 sq m) Open Space, Chepstow, Monmouthshire, NP16 5BZ	Public Open Space						
Shakespeare Drive Open Space	Shakespeare Drive Open Space, Caldicot, Monmouthshire, NP26 4LW	Public Open Space						
Shelley Close Public Open Space	Shelley Close Public Open Space, Caldicot, Monmouthshire, NP26 4LQ	Public Open Space						
Somerset Road Open Space	Somerset Road Open Space, Monmouth, Monmouthshire, NP25 5AJ	Public Open Space						
Somerset Way Open Space	Somerset Way Open Space, Chepstow, Monmouthshire, NP16 5NP	Public Open Space						
St Andrews Crescent Amenity Land (180.8 sqm)	St Andrews Crescent Amenity Land (180.8 sqm), Abergavenny, Monmouthshire, NP7 6HD	Public Open Space						
St Andrews Crescent Amenity Land (2833sqm)	St Andrews Crescent Amenity Land (2833sqm), Abergavenny, Monmouthshire, NP7 6HD	Public Open Space						
St Andrews Crescent, Highways verge at	St Andrews Crescent, Highways verge at, Abergavenny, Monmouthshire, NP7 6HD	Public Open Space						
St Davids Crescent amenity land	St Davids Crescent amenity land, Llandewi Rhydderch, Abergavenny, Monmouthshire, NP7 6HD	Public Open Space						
St Davids Road Amenity Land	St Davids Road Amenity Land, Abergavenny, Monmouthshire, NP7 6HD	Public Open Space						
St Davids Road Open Space	St Davids Road Open Space, Abergavenny, Monmouthshire, NP7 6HD	Public Open Space						
St Dials Wood Open Space	St Dials Wood Open Space, Castle Close, Monmouth, Monmouthshire, NP25 5UC	Public Open Space						
St Dubricius Gardens (869.2 sq m) Open Space	St Dubricius Gardens (869.2 sq m) Open Space, Undy, Caldicot, Monmouthshire, NP26 3FD	Public Open Space						
St Faiths Close (319.5 sq m) Open Space	St Faiths Close (319.5 sq m) Open Space, Llanfoist, Abergavenny, Monmouthshire, NP23 5LW	Public Open Space						
St Faiths Close (512.9 sq m) Open Space	St Faiths Close (512.9 sq m) Open Space, Llanfoist, Abergavenny, Monmouthshire, NP23 5LW	Public Open Space						
St Helens Road Open Space	St Helens Road Open Space, Abergavenny, Monmouthshire, NP7 5UU	Public Open Space						
St Kingsmark Avenue Public Open Space	St Kingsmark Avenue Public Open Space, Chepstow, Monmouthshire, NP16 5ND	Public Open Space						
St Lawrence Park (262 sq m) Open Space	St Lawrence Park (262 sq m) Open Space, Chepstow, Monmouthshire, NP16 6DF	Public Open Space						
St Lawrence Park (297.2 sq m) Open Space	St Lawrence Park (297.2 sq m) Open Space, Chepstow, Monmouthshire, NP16 6DF	Public Open Space						
St Lawrence Park (644.1 sq m) Open Space	St Lawrence Park (644.1 sq m) Open Space, Chepstow, Monmouthshire, NP16 6DF	Public Open Space						
St Lawrence Road Open Space (1205sqm)	St Lawrence Road Open Space (1205sqm), Bayfield, Chepstow, Monmouthshire, NP16 5RQ	Public Open Space	0.29					
St Lawrence Road Open Space (331.7sqm)	St Lawrence Road Open Space (331.7sqm), Bayfield, Chepstow, Monmouthshire, NP16 5RQ	Public Open Space	0.08					
St Stephens Place (166.5 sq m) Open Space	St Stephens Place (166.5 sq m) Open Space, Undy, Caldicot, Monmouthshire, NP26 3FD	Public Open Space						
St Tysol Close Public Open Space	St Tysol Close Public Open Space, Llansoy, Usk, Monmouthshire, NP15 1EF	Public Open Space						
Stafford Road Public Open Space	Stafford Road Public Open Space, Caldicot, Monmouthshire, NP26 5DE	Public Open Space						
Starling Close Open Space	Starling Close Open Space, Rogiet, Caldicot, Monmouthshire, NP26 3UU	Public Open Space						
Station Road Open Space	Station Road Open Space, Portskewett, Caldicot, Monmouthshire, NP26 5SF	Public Open Space						
Station Road Public Open Space	Station Road Public Open Space, Caldicot, Monmouthshire, NP26 4BU	Public Open Space						
Station Road, Land adjacent	Station Road, Land adjacent, Station Road, Rogiet, Caldicot, Monmouthshire, NP26 3FD	Public Open Space						
Stephens Crescent Amenity Land	Stephens Crescent Amenity Land, Govilon, Abergavenny, Monmouthshire, NP7 9LW	Public Open Space						
Stuart Avenue Public Open Space	Stuart Avenue Public Open Space, Chepstow, Monmouthshire, NP16 5NU	Public Open Space						
Summerhouse Lane Open Space	Summerhouse Lane Open Space, Chepstow, Monmouthshire, NP16 5SP	Public Open Space						
Sycamore Avenue (1546 sq m) Open Space	Sycamore Avenue (1546 sq m) Open Space, Abergavenny, Monmouthshire, NP7 5LW	Public Open Space	0.38 acres					
Sycamore Avenue (3210 sq m) Open Space	Sycamore Avenue (3210 sq m) Open Space, Abergavenny, Monmouthshire, NP7 5LW	Public Open Space	0.79 acres					
The Claypatch Public Open Space	The Claypatch Public Open Space, Claypatch Road, Wyesham, Monmouth, Monmouthshire, NP23 5LW	Public Open Space						
The Cross Public Open Space	The Cross Public Open Space, Sandy Lane, Caldicot, Monmouthshire, NP26 4NF	Public Open Space						
The Dove Cote Public Open Space	The Dove Cote Public Open Space, Llanfair Discoed, Chepstow, Monmouthshire, NP16 5RQ	Public Open Space						
The Headland (6145 sq m) Public Open Space	The Headland (6145 sq m) Public Open Space, Chepstow, Monmouthshire, NP16 5RQ	Public Open Space						
The Island	The Island, Wyebridge, Monmouth, Monmouthshire, NP25 3LS	Public Open Space						
The Limes Open Space	The Limes Open Space, Undy, Magor, Monmouthshire, NP26 3LU	Public Open Space						
The Mount, Land at	The Mount, Land at, Off Mount Way, Chepstow, Monmouthshire, NP16 5NF	Public Open Space						
The Paddocks Public Open Space	The Paddocks Public Open Space, Undy, Magor, Monmouthshire, NP26 3TD	Public Open Space						Rockfield Grove
The Plantation (7314sqm) Open Space	The Plantation (7314sqm) Open Space, Magor, Caldicot, Monmouthshire, NP26 3TD	Public Open Space	1.80 acres					
Toynbee Way Public Open Space	Toynbee Way Public Open Space, Osbaston, Monmouth, Monmouthshire, NP25 3LW	Public Open Space						
Tree Tops, Land adjacent	Tree Tops, Land adjacent, Vinegar Hill, Undy, Magor, Monmouthshire, NP26 3EJ	Public Open Space						

Trehonddu Open Space (East)	Trehonddu Open Space (East), Llanvihangel Crucorney, Abergavenny, Monmouthshire	Public Open Space							Coopers Meadow
Trehonddu Open Space (West)	Trehonddu Open Space (West), Llanvihangel Crucorney, Abergavenny, Monmouthshire	Public Open Space							Coopers Meadow
Trelawney Close Public Open Space	Trelawney Close Public Open Space, Usk, Monmouthshire, NP15 1SP	Public Open Space							
Troy Gardens Open Space	Troy Gardens Open Space, Monmouth, Monmouthshire, NP25 5DB	Public Open Space							
Tudor Road Amenity Land (212.8 sq m)	Tudor Road Amenity Land (212.8 sq m), Wyesham, Monmouth, Monmouthshire, NP25 5DB	Public Open Space	0.05 acres						
Tudor Road Amenity Land (327.5 sq m)	Tudor Road Amenity Land (327.5 sq m), Wyesham, Monmouth, Monmouthshire, NP25 5DB	Public Open Space	0.08 acres						
Tudor Road Amenity Land (90.35 sq m)	Tudor Road Amenity Land (90.35 sq m), Wyesham, Monmouth, Monmouthshire, NP25 5DB	Public Open Space	0.02 acres						
Tudor Road Road Open Space	Tudor Road Road Open Space, Wyesham, Monmouth, Monmouthshire, NP25 3LJ	Public Open Space							
Usk View Amenity Land	Usk View Amenity Land, Govilon, Abergavenny, Monmouthshire, NP7 9PD	Public Open Space							
Vauxhall Fields Recreation Area	Vauxhall Fields Recreation Area, Forge Road, Monmouth, Monmouthshire, NP25 5DB	Public Open Space							
Victoria Way Open Space	Victoria Way Open Space, Undy, Magor, Monmouthshire, NP26 3NW	Public Open Space							
Wallis Close Public Open Space	Wallis Close Public Open Space, Osbaston, Monmouth, Monmouthshire, NP25 3NF	Public Open Space							
Wallwern Wood Open Space (5114sqm)	Wallwern Wood Open Space (5114sqm), Bayfield, Chepstow, Monmouthshire, NP23 5LJ	Public Open Space							
Warren Slade (Part) Open Space	Warren Slade (Part) Open Space, Adj Denbigh Drive, Chepstow, Monmouthshire, NP23 5LJ	Public Open Space							Park Redding
Warren Slade Open Space	Warren Slade Open Space, Bulwark, Chepstow, Monmouthshire, NP16 5NX	Public Open Space							
Waterside Open Space	Waterside Open Space, Abergavenny, Monmouthshire, NP7 5LJ	Public Open Space							
Welsh Street & St Kingsmark (179 sq m) Public Open Space	Welsh Street & St Kingsmark (179 sq m) Public Open Space, Chepstow, Monmouthshire, NP23 5LJ	Public Open Space							
Welsh Street & St Kingsmark (355 sq m) Public Open Space	Welsh Street & St Kingsmark (355 sq m) Public Open Space, Chepstow, Monmouthshire, NP23 5LJ	Public Open Space							
Wentwood View (144 sq m) Open Space	Wentwood View (144 sq m) Open Space, Caldicot, Monmouthshire, NP26 4QH	Public Open Space							
Wentwood View (162.6 sq m) Open Space	Wentwood View (162.6 sq m) Open Space, Caldicot, Monmouthshire, NP26 4QH	Public Open Space							
Wentwood View (250.00 sq m) Open Space	Wentwood View (250.00 sq m) Open Space, Caldicot, Monmouthshire, NP26 4QH	Public Open Space							
Wentwood View (340.6 sq m) Open Space	Wentwood View (340.6 sq m) Open Space, Caldicot, Monmouthshire, NP26 4QH	Public Open Space							
Wentwood View (487.5 sq m) Open Space	Wentwood View (487.5 sq m) Open Space, Caldicot, Monmouthshire, NP26 4QH	Public Open Space							
Wentwood View Caldicot Open Space	Wentwood View Caldicot Open Space, Caldicot, Monmouthshire, NP7 9DE	Public Open Space							Former Pony Club
Westfield Open Space	Westfield Open Space, Caldicot, Monmouthshire, NP26 4HE	Public Open Space							
Westfield Road Public Open Space	Westfield Road Public Open Space, Osbaston, Monmouth, Monmouthshire, NP25 5DB	Public Open Space							
Whitechapel Walk Open Space	Whitechapel Walk Open Space, Undy, Magor, Monmouthshire, NP26 3NS	Public Open Space							
Willow Drive (404.6sqm) Public Open Space	Willow Drive (404.6sqm) Public Open Space, Monmouth, Monmouthshire, NP25 5DB	Public Open Space	0.09 acres						
Willow Drive (4708 sq m) Open Space	Willow Drive (4708 sq m) Open Space, Monmouth, Monmouthshire, NP25 5DW	Public Open Space	1.16 acres						
Windsor Close Open Space	Windsor Close Open Space, Magor, Monmouthshire, NP26 3PX	Public Open Space							
Windsor Park Open Space	Windsor Park Open Space, Magor, Monmouthshire, NP26 3NJ	Public Open Space							
Woodland Crescent Open Space	Woodland Crescent Open Space, Woodland Crescent, Llanfoist, Abergavenny, Monmouthshire, NP23 5LJ	Public Open Space							
Woodstock Way Public Open Space	Woodstock Way Public Open Space, Caldicot, Monmouthshire, NP26 5DB	Public Open Space							
Woolpitch Open Space (18390sqm)	Woolpitch Open Space (18390sqm), Bayfield, Chepstow, Monmouthshire, NP16 6DW	Public Open Space							
Woolpitch Wood Open Space (520.2 sqm)	Woolpitch Wood Open Space (520.2 sqm), Bayfield, Chepstow, Monmouthshire, NP16 6DW	Public Open Space	0.12 acres						
Woolpitch Wood Open Space (54.99sqm)	Woolpitch Wood Open Space (54.99sqm), Chepstow, Monmouthshire, NP16 6DW	Public Open Space							
Woolpitch Wood Open Space (583.6 sqm)	Woolpitch Wood Open Space (583.6 sqm), Bayfield, Chepstow, Monmouthshire, NP16 6DW	Public Open Space	0.14 acres						
Woolpitch Wood Open Space (5846 sqm)	Woolpitch Wood Open Space (5846 sqm), Bayfield, Chepstow, Monmouthshire, NP16 6DW	Public Open Space	1.44 acres						
Woolpitch Wood Open Space (59.5sqm)	Woolpitch Wood Open Space (59.5sqm), Chepstow, Monmouthshire, NP16 6DW	Public Open Space							
Wyebriidge Street, Land at	Wyebriidge Street, Land at, Monmouth, Monmouthshire, NP25 3DL	Public Open Space							
Wyesham Road Open Space	Wyesham Road Open Space, Wyesham, Monmouth, Monmouthshire, NP25 3JR	Public Open Space							
Yew Tree Rise (4972 sq m) Open Space	Yew Tree Rise (4972 sq m) Open Space, Rogiet, Caldicot, Monmouthshire, NP26 4HE	Public Open Space	1.22 acres						
1 - 7 The Willows, Highway fronting	The Willows 1 - 7, Highway fronting, Magor, Caldicot, Monmouthshire	Road/pavement	N/A	N/A	N/A	N/A	N/A	N/A	Unsuitable
1 & 2 Chestnut Court, Highway fronting	Chestnut Court 1 & 2, Highway fronting, Wyesham, Monmouth, Monmouthshire	Road/pavement	N/A	N/A	N/A	N/A	N/A	N/A	Unsuitable
1 Blenheim Avenue, Highway fronting	Blenheim Avenue, 1, Highway fronting, Magor, Caldicot, Monmouthshire	Road/pavement	N/A	N/A	N/A	N/A	N/A	N/A	Unsuitable
1 Clear View, Highway land at	Clear View 1, Highway land at, Tintern, Monmouthshire	Road/pavement	N/A	N/A	N/A	N/A	N/A	N/A	Unsuitable
1 Dan y Bryn, Highway fronting	Dan y Bryn, 1, Highway fronting, Llanellen, Abergavenny, Monmouthshire	Road/pavement	N/A	N/A	N/A	N/A	N/A	N/A	Unsuitable
1 White House Gardens, Highway fronting	White House Gardens, 1, Highway fronting, Little Mill, Pontypool	Road/pavement	N/A	N/A	N/A	N/A	N/A	N/A	Unsuitable
10 & 14 Chepstow Road, Highway fronting	Chepstow Road, 10 & 14, Highway fronting, Caldicot, Monmouthshire	Road/pavement	N/A	N/A	N/A	N/A	N/A	N/A	Unsuitable
1-3 Berthon Road, Highway fronting	Berthon Road 1-3, Highway fronting, Little Mill, Pontypool, Torfaen	Road/pavement	N/A	N/A	N/A	N/A	N/A	N/A	Unsuitable
13 High Street, Highway to the rear of	High Street, 13, Highway to the rear of, Bank Street, Chepstow, Monmouthshire	Road/pavement	N/A	N/A	N/A	N/A	N/A	N/A	Unsuitable
1-4 Cae Meldon, Highway land adjacent to	Cae Meldon 1-4, Highway land adjacent to, Gilwern, Abergavenny, Monmouthshire	Road/pavement	N/A	N/A	N/A	N/A	N/A	N/A	Unsuitable
1-4 St Helens Close, (B4269) Highway fronting	St Helens Close, 1-4, (B4269) Highway fronting, Llanellen, Abergavenny, Monmouthshire	Road/pavement	N/A	N/A	N/A	N/A	N/A	N/A	Unsuitable
14 St Mary Street, Highway to the rear of	St Mary Street, 14, Highway to the rear of, Chepstow, Monmouthshire	Road/pavement	N/A	N/A	N/A	N/A	N/A	N/A	Unsuitable
15 Langley Close, Highway fronting	Langley Close, 15, Highway fronting, Magor, Caldicot, Monmouthshire	Road/pavement	N/A	N/A	N/A	N/A	N/A	N/A	Unsuitable
15 Whitecross Street, Land fronting	Whitecross Street, 15, Land fronting, Monmouth, Monmouthshire, NP25 3BY	Road/pavement	N/A	N/A	N/A	N/A	N/A	N/A	Unsuitable
15,16 & 17a High Street, Highway to the rear of	High Street, 15, 16 & 17a, Highway to the rear of, Chepstow, Monmouthshire	Road/pavement	N/A	N/A	N/A	N/A	N/A	N/A	Unsuitable
152 Newport Road, Highway to the rear & adjoining	Newport Road, 152, Highway to the rear & adjoining, Caldicot, Monmouthshire	Road/pavement	N/A	N/A	N/A	N/A	N/A	N/A	Unsuitable
155 - 193 Newport Road, Highway fronting	Newport Road, 155 - 193, Highway fronting, Caldicot, Monmouthshire	Road/pavement	N/A	N/A	N/A	N/A	N/A	N/A	Unsuitable
16 & 18 High Beech Lane, Highway fronting	High Beech Lane, 16 & 18, Highway fronting, Chepstow, Monmouthshire	Road/pavement	N/A	N/A	N/A	N/A	N/A	N/A	Unsuitable
1-6 Porthycarne Lane, Highway at	Porthycarne Lane, 1-6, Highway at, Usk, Monmouthshire	Road/pavement	N/A	N/A	N/A	N/A	N/A	N/A	Unsuitable
16, 17-18 Clawdd Du, Land to the rear of	Clawdd Du 16, 17 & 18, Land to the rear of, Monmouth, Monmouthshire, NP25 5BJ	Road/pavement	N/A	N/A	N/A	N/A	N/A	N/A	Unsuitable
164 & 166 Newport Road, Highway fronting	Newport Road, 164 & 166, Highway fronting, Caldicot, Monmouthshire	Road/pavement	N/A	N/A	N/A	N/A	N/A	N/A	Unsuitable
168 Newport Road, Highway fronting	Newport Road, 168, Highway fronting, Caldicot, Monmouthshire	Road/pavement	N/A	N/A	N/A	N/A	N/A	N/A	Unsuitable
17 & 18 Cross Street, Highway land fronting	Cross Street, 17 & 18, Highway land fronting, Abergavenny, Monmouthshire	Road/pavement	N/A	N/A	N/A	N/A	N/A	N/A	Unsuitable
186 - 204 Newport Road Highway between	Newport Road, 186-204 Highway between, Caldicot, Monmouthshire	Road/pavement	N/A	N/A	N/A	N/A	N/A	N/A	Unsuitable
19 - 21 High Street, Highway to the rear of	High Street, 19 - 21, Highway to the rear of, Chepstow, Monmouthshire	Road/pavement	N/A	N/A	N/A	N/A	N/A	N/A	Unsuitable
19 - 22 Fairholme, Highway fronting	Fairholme, 19 - 22, Highway fronting, Gilwern, Abergavenny, Monmouthshire	Road/pavement	N/A	N/A	N/A	N/A	N/A	N/A	Unsuitable
1-9 Fairholme, Highway fronting	Fairholme, 1 - 9, Highway fronting, Gilwern, Abergavenny, Monmouthshire	Road/pavement	N/A	N/A	N/A	N/A	N/A	N/A	Unsuitable
2 Brooklyn Cottage, Highway land opposite	Brooklyn Cottage, 2, Highway land opposite, Clydach, Abergavenny, Monmouthshire	Road/pavement	N/A	N/A	N/A	N/A	N/A	N/A	Unsuitable
2 High Street, Land to the rear	High Street, 2 Land to the rear, Chepstow, Monmouthshire	Road/pavement	N/A	N/A	N/A	N/A	N/A	N/A	Unsuitable
20,22 & 24 Nevill Street & 9 & 11 St Johns Sq	Nevill Street, 20, 22 & 24 and St Johns Sq, 9 & 11, Abergavenny, Monmouthshire	Road/pavement	N/A	N/A	N/A	N/A	N/A	N/A	Unsuitable

Formerly 152 - 162 Newport Road

23 High Street, Highway land fronting	High Street, 23, Highway land fronting, Chepstow, Monmouthshire	Road/pavement	N/A	N/A	N/A	N/A	Unsuitable	
236 - 238 Newport Road, Highway between	Newport Road, 236 - 238, Highway between, Caldicot, Monmouthshire	Road/pavement	N/A	N/A	N/A	N/A	Unsuitable	
27 Main Road, Land adjacent to	Main Road 27, Land adjacent to, Portskewett, Caldicot, Monmouthshire, NP26 5S	Road/pavement	N/A	N/A	N/A	N/A	Unsuitable	
2A Chepstow Road, Highway adjacent	Chepstow Road, 2A, Highway adjacent, Caldicot, Monmouthshire	Road/pavement	N/A	N/A	N/A	N/A	Unsuitable	
3 - 11 High Street, Highway to the rear of	High Street, 3 - 11, Highway to the rear of, Chepstow, Monmouthshire	Road/pavement	N/A	N/A	N/A	N/A	Unsuitable	
4 Oxford Street, Highway adjoining	Oxford Street, 4, Highway adjoining, Chepstow, Monmouthshire	Road/pavement	N/A	N/A	N/A	N/A	Unsuitable	
40 Berthon Road, Highway fronting	Berthon Road, 40, Highway fronting, Little Mill, Pontypool, Torfaen	Road/pavement	N/A	N/A	N/A	N/A	Unsuitable	
40 Main Road, Land fronting	Main Road 40, Land fronting, Portskewett, Caldicot, Monmouthshire, NP26 5SA	Road/pavement	N/A	N/A	N/A	N/A	Unsuitable	
42 Berthon Road, Highway fronting	Berthon Road, 42, Highway fronting, Little Mill, Pontypool, Torfaen	Road/pavement	N/A	N/A	N/A	N/A	Unsuitable	
44 Berthon Road, Highway fronting	Berthon Road, 44, Highway fronting, Little Mill, Pontypool, Torfaen	Road/pavement	N/A	N/A	N/A	N/A	Unsuitable	
45a & 46a Brook Estate, Land fronting	Brook Estate 45a & 45b, Land fronting, Monmouth, Monmouthshire	Road/pavement	N/A	N/A	N/A	N/A	Unsuitable	
50 St Helens Road, Land adjoining	St Helens Road, 50, Land adjoining, Abergavenny, Monmouthshire	Road/pavement	N/A	N/A	N/A	N/A	Unsuitable	
55 Main Road, Land fronting	Main Road 55, Land fronting, Portskewett, Caldicot, Monmouthshire, NP26 5UG	Road/pavement	N/A	N/A	N/A	N/A	Unsuitable	
66 Brecon Road, Highway fronting	Brecon Road, 66, Highway fronting, Abergavenny, Monmouth	Road/pavement	N/A	N/A	N/A	N/A	Unsuitable	
8 - 18 Plough Road & Plough House, Highway fronting	Plough Road 8 - 18 & Plough House, Highway fronting, Penperlleni, Pontypool, Monmouth	Road/pavement	N/A	N/A	N/A	N/A	Unsuitable	
80-86 Berthon Road, Highway fronting	Berthon Road 80 - 86, Highway fronting, Little Mill, Pontypool	Road/pavement	N/A	N/A	N/A	N/A	Unsuitable	
9 Park Crescent, Highway fronting	Park Crescent, 9, Highway fronting, Abergavenny, Monmouthshire	Road/pavement	N/A	N/A	N/A	N/A	Unsuitable	
A4042 & A472, Highway on junction of	A4042 & A472, Highway on junction of, Little Mill, Pontypool	Road/pavement	N/A	N/A	N/A	N/A	Unsuitable	
A4077 Crickhowell Road (113.8 sq m), Highway land	A4077 Crickhowell Road (113.8 sq m), Highway land, Gilwern, Abergavenny, Monmouth	Road/pavement	N/A	N/A	N/A	N/A	Unsuitable	
A4077 Crickhowell Road (13.37 sq m), Highway land	A4077 Crickhowell Road (13.37 sq m), Highway land, Gilwern, Abergavenny, Monmouth	Road/pavement	N/A	N/A	N/A	N/A	Unsuitable	
A4077 Crickhowell Road (1937 sq m), Highway land	A4077 Crickhowell Road (1937 sq m), Highway land, Gilwern, Abergavenny, Monmouth	Road/pavement	N/A	N/A	N/A	N/A	Unsuitable	
A4077 Crickhowell Road (46.46 sq m), Highway land	A4077 Crickhowell Road (46.46 sq m), Highway land, Gilwern, Abergavenny, Monmouth	Road/pavement	N/A	N/A	N/A	N/A	Unsuitable	
A4077 Crickhowell Road (71.29 sq m), Highway land	A4077 Crickhowell Road (71.29 sq m), Highway land, Gilwern, Abergavenny, Monmouth	Road/pavement	N/A	N/A	N/A	N/A	Unsuitable	
A4077 Crickhowell Road, (159.4 sq m) Highway land	A4077 Crickhowell Road, (159.4 sq m) Highway land, Gilwern, Abergavenny, Monmouth	Road/pavement	N/A	N/A	N/A	N/A	Unsuitable	
A449 (Opposite Newbridge on Usk Picnic site), Land off	A449 (Opposite Newbridge on Usk Picnic site), Land off, Llantrisant, Usk, Monmouth	Road/pavement	N/A	N/A	N/A	N/A	Unsuitable	
A466 Wyndcliff Wood, Highway land off	A466 Wyndcliff Wood, Highway land off, St Arvans, Chepstow, Monmouthshire	Road/pavement	N/A	N/A	N/A	N/A	Unsuitable	
A466 Lower Wyndcliff Wood, Highway land off	A466 Lower Wyndcliff Wood, Highway land off, St Arvans, Chepstow, Monmouthshire	Road/pavement	N/A	N/A	N/A	N/A	Unsuitable	
A466, Crossway Green, Highway	A466, Crossway Green, Highway, Chepstow, Monmouthshire	Road/pavement	N/A	N/A	N/A	N/A	Unsuitable	
Abbey Lodge, Highway land fronting & adjacent property	Abbey Lodge, Highway land fronting & adjacent properties, Tintern, Monmouthshire	Road/pavement	N/A	N/A	N/A	N/A	Unsuitable	
Abergavenny Road, Highway near	Abergavenny Road, Highway near, Cross Roads, Gilwern, Abergavenny, Monmouth	Road/pavement	N/A	N/A	N/A	N/A	Unsuitable	
Access Road to Former Brecon Road Depot	Access Road to Former Brecon Road Depot, Brecon Road, Abergavenny, Monmouth	Road/pavement	N/A	N/A	N/A	N/A	Unsuitable	
Access Road to Llwynu Infants & Nursery Unit	Access Road to Llwynu Infants & Nursery Unit, St David's Road, Abergavenny, Monmouth	Road/pavement	N/A	N/A	N/A	N/A	Unsuitable	
Albion House, Highway fronting	Albion House, Highway fronting, Magor, Caldicot, Monmouthshire	Road/pavement	N/A	N/A	N/A	N/A	Unsuitable	
Alexander Place, Highway opposite	Alexander Place, Highway opposite, Little Mill, Usk, Monmouthshire	Road/pavement	N/A	N/A	N/A	N/A	Unsuitable	
Anglecot, Highway land adjacent to	Anglecot, Highway land adjacent to, Mathern, Chepstow, Monmouthshire	Road/pavement	N/A	N/A	N/A	N/A	Unsuitable	
Anglecot, Highway land opposite	Anglecot, Highway land opposite, Mathern, Chepstow, Monmouthshire	Road/pavement	N/A	N/A	N/A	N/A	Unsuitable	
Ashford Cottage, Highway land adjacent to	Ashford Cottage, Highway land adjacent to, Glascoed, Pontypool, Monmouthshire	Road/pavement	N/A	N/A	N/A	N/A	Unsuitable	
Ashleigh & Garden House, Highway fronting between	Ashleigh & Garden House, Highway fronting between, Chepstow, Monmouthshire	Road/pavement	N/A	N/A	N/A	N/A	Unsuitable	
Atherstone, Highway near	Atherstone, Highway near, Rockfield, Monmouth, Monmouthshire	Road/pavement	N/A	N/A	N/A	N/A	Unsuitable	
Athrotha, Highway land adjacent to	Athrotha, Highway land adjacent to, Crickhowell Road, Gilwern, Abergavenny, Monmouth	Road/pavement	N/A	N/A	N/A	N/A	Unsuitable	
B4235 Chepstow to Usk Road, Highway	B4235 Chepstow to Usk Road, Highway, New Church, Chepstow, Monmouthshire	Road/pavement	N/A	N/A	N/A	N/A	Unsuitable	
B4235 Usk to Chepstow Road, Highway	B4235 Usk to Chepstow Road, Highway, New Church, Chepstow, Monmouthshire	Road/pavement	N/A	N/A	N/A	N/A	Unsuitable	
B4245 & M4, (2483 sq m) Highway between	B4245 & M4, (2483 sq m) Highway between, Magor, Caldicot, Monmouthshire	Road/pavement	N/A	N/A	N/A	N/A	Unsuitable	
B4245 & M4, Highway between	B4245 & M4, Highway between, Magor, Caldicot, Monmouthshire	Road/pavement	N/A	N/A	N/A	N/A	Unsuitable	
B4245 (4456 sq m), Highway at	B4245 (4456 sq m), Highway at, Caldicot, Monmouthshire	Road/pavement	N/A	N/A	N/A	N/A	Unsuitable	
B4245 Caldicot to Chepstow Road (1)	B4245 Caldicot to Chepstow Road (1), Caldicot, Monmouthshire	Road/pavement	N/A	N/A	N/A	N/A	Unsuitable	
B4245 Caldicot to Chepstow Road (2)	B4245 Caldicot to Chepstow Road (2), Caldicot, Monmouthshire	Road/pavement	N/A	N/A	N/A	N/A	Unsuitable	
B4245 Caldicot to Chepstow Road (3)	B4245 Caldicot to Chepstow Road (3), Caldicot, Monmouthshire	Road/pavement	N/A	N/A	N/A	N/A	Unsuitable	
B4245 Caldicot to Chepstow Road (4)	B4245 Caldicot to Chepstow Road (4), Caldicot, Monmouthshire	Road/pavement	N/A	N/A	N/A	N/A	Unsuitable	
B4245 Caldicot to Chepstow Road (5)	B4245 Caldicot to Chepstow Road (5), Caldicot, Monmouthshire	Road/pavement	N/A	N/A	N/A	N/A	Unsuitable	
B4245 intersection, Highway	B4245 intersection, Highway, Magor, Caldicot, Monmouthshire	Road/pavement	N/A	N/A	N/A	N/A	Unsuitable	
B4245 Rogiet Road, Highway	B4245 Rogiet Road, Highway, Rogiet, Caldicot, Monmouthshire	Road/pavement	N/A	N/A	N/A	N/A	Unsuitable	
B4245, (1968 Sq m) Highway land	B4245, (1968 Sq m) Highway land, Undy, Caldicot, Monmouthshire	Road/pavement	N/A	N/A	N/A	N/A	Unsuitable	
B4246 Blaenavon to Gilwern, Highway between	B4246 Blaenavon to Gilwern, Highway between, Govilon, Monmouthshire	Road/pavement	N/A	N/A	N/A	N/A	Unsuitable	
B4248 Brynmawr to Blaenavon Rd (2), Hway land	B4248 Brynmawr to Blaenavon Rd (2), Hway land, Abergavenny, Monmouthshire	Road/pavement	N/A	N/A	N/A	N/A	Unsuitable	Station House Waunavon
B4248 Blaenavon to Brynmawr Road (1), Hway land at	B4248 Blaenavon to Brynmawr Road (1), Hway land at, Abergavenny, Monmouthshire	Road/pavement	N/A	N/A	N/A	N/A	Unsuitable	Station House Waunavon
B4269 Llanfoist to Llanellen Road, Highway at	B4269 Llanfoist to Llanellen Road, Highway at, Llanfoist, Abergavenny, Monmouth	Road/pavement	N/A	N/A	N/A	N/A	Unsuitable	
B4293 & A40, Highway land at junction of	B4293 & A40, Highway land at junction of, Monmouth, Monmouthshire	Road/pavement	N/A	N/A	N/A	N/A	Unsuitable	
B4293 Itton Road (1), Highway at	B4293 Itton Road (1), Highway at, Chepstow, Monmouthshire	Road/pavement	N/A	N/A	N/A	N/A	Unsuitable	
B4293 Itton Road (2), Highway at	B4293 Itton Road (2), Highway at, Chepstow, Monmouthshire	Road/pavement	N/A	N/A	N/A	N/A	Unsuitable	
B4293 Itton Road (3), Highway at	B4293 Itton Road (3), Highway at, Chepstow, Monmouthshire	Road/pavement	N/A	N/A	N/A	N/A	Unsuitable	
B4293 Itton Road (450 sq m), Highway at	B4293 Itton Road (450 sq m), Highway at, Fryrth Wood, Chepstow, Monmouthshire	Road/pavement	N/A	N/A	N/A	N/A	Unsuitable	
B4598 Llancayo to Usk Road, Highway land	B4598 Llancayo to Usk Road, Highway land, Llancayo, Usk, Monmouthshire	Road/pavement	N/A	N/A	N/A	N/A	Unsuitable	
B4598, Highway at	B4598, Highway at, Llanvair Kilgeddin, Abergavenny, Monmouthshire	Road/pavement	N/A	N/A	N/A	N/A	Unsuitable	
Baiden Brook, B4246, Highway near	Baiden Brook, B4246, Highway near, Gilwern, Abergavenny, Monmouthshire	Road/pavement	N/A	N/A	N/A	N/A	Unsuitable	
Bailey's Hay, Highway verge at	Bailey's Hay, Highway verge at, Mathern, Chepstow, Monmouthshire	Road/pavement	N/A	N/A	N/A	N/A	Unsuitable	
Bandaloop, Highway land near	Bandaloop, Highway land near, Shirenewton, Chepstow, Monmouthshire	Road/pavement	N/A	N/A	N/A	N/A	Unsuitable	
Barclays Bank, Highway adjacent to	Barclays Bank, Highway adjacent to, Bank Street, Chepstow, Monmouthshire	Road/pavement	N/A	N/A	N/A	N/A	Unsuitable	
Barclays Bank, Highway to the rear of	Barclays Bank, Highway to the rear of, Bank Street, Chepstow, Monmouthshire	Road/pavement	N/A	N/A	N/A	N/A	Unsuitable	
Beaufort Arms, Highway fronting	Beaufort Arms, Highway fronting, Monkwood, Usk, Monmouthshire	Road/pavement	N/A	N/A	N/A	N/A	Unsuitable	
Beaufort Arms, Highway opposite	Beaufort Arms, Highway opposite, Monkwood, Usk, Monmouthshire	Road/pavement	N/A	N/A	N/A	N/A	Unsuitable	
Beaufort Cottage, Highway opposite	Beaufort Cottage, Highway opposite, Tintern, Chepstow, Monmouthshire	Road/pavement	N/A	N/A	N/A	N/A	Unsuitable	

Beaufort Square, 3, 4, & 5 Highway land fronting	Beaufort Square, 3, 4, & 5 Highway land fronting, Chepstow, Monmouthshire	Road/pavement	N/A	N/A	N/A	N/A	Unsuitable	
Beech Hill Cottage, Highway at	Beech Hill Cottage, Highway at, Gwehelog, Usk, Monmouthshire	Road/pavement	N/A	N/A	N/A	N/A	Unsuitable	
Beech Road , Highway land at rear of	Beech Road , Highway land at rear of, Monmouth, Monmouthshire	Road/pavement	N/A	N/A	N/A	N/A	Unsuitable	Part of A40
Beech Road, Highway verge at	Beech Road, Highway verge at, Caldicot, Monmouthshire	Road/pavement	N/A	N/A	N/A	N/A	Unsuitable	
Berllan-deg, Highway land at	Berllan-deg, Highway land at, LLwyncelyn, Newport	Road/pavement	N/A	N/A	N/A	N/A	Unsuitable	
Bierlow, Highway land adjacent to	Bierlow, Highway land adjacent to, Common Road, Gilwern, Abergavenny, Monmouthshire	Road/pavement	N/A	N/A	N/A	N/A	Unsuitable	
Bigsweir Bridge, Highway at	Bigsweir Bridge, Highway at, St Briavels, Lydney	Road/pavement	N/A	N/A	N/A	N/A	Unsuitable	
Black Bear, Highway opposite	Black Bear, Highway opposite, Bettws Newydd, Usk, Monmouthshire	Road/pavement	N/A	N/A	N/A	N/A	Unsuitable	
Blethyn Close, Highway & Pavement at	Blethyn Close, Highway & Pavement at, Shirenewton, Chepstow, Monmouthshire	Road/pavement	N/A	N/A	N/A	N/A	Unsuitable	
Blethyn Close, Highway land at	Blethyn Close, Highway land at, Shirenewton, Chepstow, Monmouthshire	Road/pavement	N/A	N/A	N/A	N/A	Unsuitable	
Bloreng Road Electricity Sub Station	Bloreng Road Electricity Sub Station, Abergavenny, Monmouthshire	Road/pavement	N/A	N/A	N/A	N/A	Unsuitable	Park Avenue
Boverton House, Highway land fronting	Boverton House, Highway land fronting, Bulwark Road, Chepstow, Monmouthshire	Road/pavement	N/A	N/A	N/A	N/A	Unsuitable	
Brewery House, Highway land adjacent to	Brewery House, Highway land adjacent to, Upper Redbrook, Monmouth, Monmouthshire	Road/pavement	N/A	N/A	N/A	N/A	Unsuitable	
Bridgend Inn, Highway adjacent to	Bridgend Inn, Highway adjacent to, Main Road, Gilwern, Abergavenny, Monmouthshire	Road/pavement	N/A	N/A	N/A	N/A	Unsuitable	
Brockhurst, Highway opposite	Brockhurst, Highway opposite, LLanishen, Chepstow, Monmouthshire	Road/pavement	N/A	N/A	N/A	N/A	Unsuitable	
Brockweir Bridge, Highway at	Brockweir Bridge, Highway at, Brockweir, Chepstow, Monmouthshire	Road/pavement	N/A	N/A	N/A	N/A	Unsuitable	
Brook Cottage, Highway opposite	Brook Cottage, Highway opposite, Little Mill, Usk, Monmouthshire	Road/pavement	N/A	N/A	N/A	N/A	Unsuitable	
Brookside Bungalow, (B4269)Highway fronting	Brookside Bungalow, (B4269)Highway fronting, Llanellen, Abergavenny, Monmouthshire	Road/pavement	N/A	N/A	N/A	N/A	Unsuitable	
Bryn View, Highway near	Bryn View, Highway near, Plough Road, Penperleni, Pontypool	Road/pavement	N/A	N/A	N/A	N/A	Unsuitable	
Buckholt Cottage, Highway at	Buckholt Cottage, Highway at, Buckholt, Monmouth, Monmouthshire	Road/pavement	N/A	N/A	N/A	N/A	Unsuitable	
Bulwark Business Park, (140sq m) Highway land fronting	Bulwark Business Park, (140sq m) Highway land fronting, Bulwark Road, Chepstow, Monmouthshire	Road/pavement	N/A	N/A	N/A	N/A	Unsuitable	
Bulwark Business Park, (192sq m) Highway land fronting	Bulwark Business Park, (192sq m) Highway land fronting, Bulwark Road, Chepstow, Monmouthshire	Road/pavement	N/A	N/A	N/A	N/A	Unsuitable	
Bulwark Road Shops, Highway land adjacent to	Bulwark Road Shops, Highway land adjacent to, Bulwark Road, Chepstow, Monmouthshire	Road/pavement	N/A	N/A	N/A	N/A	Unsuitable	
Burnt Barn Road, Highway verge	Burnt Barn Road, Highway verge, Chepstow, Monmouthshire	Road/pavement	N/A	N/A	N/A	N/A	Unsuitable	
Bush House, Highway land adjacent to	Bush House, Highway land adjacent to, Upper Redbrook, Monmouth, Monmouthshire	Road/pavement	N/A	N/A	N/A	N/A	Unsuitable	
C532 Llanwechfa, Land adjoining	C532 Llanwechfa, Land adjoining, Llandenny, Usk, Monmouthshire	Road/pavement	N/A	N/A	N/A	N/A	Unsuitable	
Cae Maen, Highway fronting	Cae Maen, Highway fronting, Blaenavon Road, Govilon, Abergavenny, Monmouthshire	Road/pavement	N/A	N/A	N/A	N/A	Unsuitable	
Caestory Crescent Electricity Sub Station	Caestory Crescent Electricity Sub Station, Raglan, Monmouthshire, NP15 2EG	Road/pavement	N/A	N/A	N/A	N/A	Unsuitable	
Caldicot Methodist Church, Highway fronting	Caldicot Methodist Church, Highway fronting, Caldicot, Monmouthshire	Road/pavement	N/A	N/A	N/A	N/A	Unsuitable	
Caldicot Road & Caldicot By Pass, Highway corner of	Caldicot Road & Caldicot By Pass, Highway corner of, Caldicot, Monmouthshire	Road/pavement	N/A	N/A	N/A	N/A	Unsuitable	
Caldicot Road, (547 sq m) Highway	Caldicot Road, (547 sq m) Highway, Undy, Caldicot, Monmouthshire	Road/pavement	N/A	N/A	N/A	N/A	Unsuitable	
Caldicot Road, (84 sq m) Highway	Caldicot Road, (84 sq m) Highway, Rogiet, Caldicot, Monmouthshire	Road/pavement	N/A	N/A	N/A	N/A	Unsuitable	
Caldicot Road, 2, (25 sq m) Highway fronting	Caldicot Road, 2, (25 sq m) Highway fronting, Rogiet, Caldicot, Monmouthshire	Road/pavement	N/A	N/A	N/A	N/A	Unsuitable	
Caldicot Road, 20, (18 sq m) Highway	Caldicot Road, 20, (18 sq m) Highway, Rogiet, Caldicot, Monmouthshire	Road/pavement	N/A	N/A	N/A	N/A	Unsuitable	
Caldicot Road, 22, (4.09 sq m) Highway fronting	Caldicot Road, 22, (4.09 sq m) Highway fronting, Rogiet, Caldicot, Monmouthshire	Road/pavement	N/A	N/A	N/A	N/A	Unsuitable	
Caldicot Road, B4245, (3261 sq m) Highway	Caldicot Road, B4245, (3261 sq m) Highway, Rogiet, Caldicot, Monmouthshire	Road/pavement	N/A	N/A	N/A	N/A	Unsuitable	
Caldicot Road, B4245, (4515 sq m) Highway	Caldicot Road, B4245, (4515 sq m) Highway, Rogiet, Caldicot, Monmouthshire	Road/pavement	N/A	N/A	N/A	N/A	Unsuitable	
Canal Bridge near Navigation Hotel, Highway	Canal Bridge near Navigation Hotel, Highway, Main Road, Gilwern, Abergavenny, Monmouthshire	Road/pavement	N/A	N/A	N/A	N/A	Unsuitable	
Carpenters Arms, Highway opposite	Carpenters Arms, Highway opposite, Shirenewton, Chepstow, Monmouthshire	Road/pavement	N/A	N/A	N/A	N/A	Unsuitable	
Carpenters Row, Land fronting	Carpenters Row, Land fronting, Govilon, Abergavenny, Monmouthshire	Road/pavement	N/A	N/A	N/A	N/A	Unsuitable	
Cartref, Highway near	Cartref, Highway near, The Onen, Talycoed, Monmouth, Monmouthshire	Road/pavement	N/A	N/A	N/A	N/A	Unsuitable	
Castle Lea & Castle Lodge Crescent, Highway fronting	Castle Lea & Castle Lodge Crescent, Highway fronting, Caldicot, Monmouthshire	Road/pavement	N/A	N/A	N/A	N/A	Unsuitable	
Castle Way, Highway at	Castle Way, Highway at, Caldicot, Monmouthshire	Road/pavement	N/A	N/A	N/A	N/A	Unsuitable	
Castle Way, Highway at	Castle Way, Highway at, Caldicot, Monmouthshire	Road/pavement	N/A	N/A	N/A	N/A	Unsuitable	Severnbridge
Central Reservation at Hillcrest	Central Reservation at Hillcrest, Abergavenny, Monmouthshire	Road/pavement	N/A	N/A	N/A	N/A	Unsuitable	
Chapel Farm, Highway adjacent to	Chapel Farm, Highway adjacent to, Monkswood, Usk, Monmouthshire	Road/pavement	N/A	N/A	N/A	N/A	Unsuitable	
Chaucer Close Electricity Sub Station	Chaucer Close Electricity Sub Station, Caldicot, Monmouthshire	Road/pavement	N/A	N/A	N/A	N/A	Unsuitable	
Cheesman's Trading Estate, Highway near	Cheesman's Trading Estate, Highway near, Rogiet, Caldicot, Monmouthshire	Road/pavement	N/A	N/A	N/A	N/A	Unsuitable	
Chepstow Community Council, Highway fronting	Chepstow Community Council, Highway fronting, Chepstow, Monmouthshire	Road/pavement	N/A	N/A	N/A	N/A	Unsuitable	
Chepstow Racecourse, Highway land opposite	Chepstow Racecourse, Highway land opposite, St Arvans, Chepstow, Monmouthshire	Road/pavement	N/A	N/A	N/A	N/A	Unsuitable	
Cherrytree Farm, Highway opposite	Cherrytree Farm, Highway opposite, Skenfrith, Abergavenny, Monmouthshire	Road/pavement	N/A	N/A	N/A	N/A	Unsuitable	
Chestnut Close, Highway fronting	Chestnut Close, Highway fronting, Magor, Caldicot, Monmouthshire	Road/pavement	N/A	N/A	N/A	N/A	Unsuitable	
Church Farm, Highway fronting	Church Farm, Highway fronting, Wyesham, Monmouth, Monmouthshire	Road/pavement	N/A	N/A	N/A	N/A	Unsuitable	
Churchfield Avenue, Highway land at	Churchfield Avenue, Highway land at, Caldicot, Monmouthshire	Road/pavement	N/A	N/A	N/A	N/A	Unsuitable	
Cinderhill Street, Highway land at	Cinderhill Street, Highway land at, Monmouth, Monmouthshire	Road/pavement	N/A	N/A	N/A	N/A	Unsuitable	St Thomas Square
Cinderhill Street, Land adjacent to	Cinderhill Street, Land adjacent to, Monmouth, Monmouthshire	Road/pavement	N/A	N/A	N/A	N/A	Unsuitable	
Cinderhill Street, Land adjacent to Petrol Station	Cinderhill Street, Land adjacent to Petrol Station, Monmouth, Monmouthshire	Road/pavement	N/A	N/A	N/A	N/A	Unsuitable	
Cinderhill Street, Pavement fronting	Cinderhill Street, Pavement fronting, Monmouth, Monmouthshire	Road/pavement	N/A	N/A	N/A	N/A	Unsuitable	
Clydach Sewerage Disposal Works	Clydach Sewerage Disposal Works, Clydach, Abergavenny, Monmouthshire	Road/pavement	N/A	N/A	N/A	N/A	Unsuitable	
Clydach to Blaenavon Road (1), Highway land at	Clydach to Blaenavon Road (1), Highway land at, Abergavenny, Monmouthshire	Road/pavement	N/A	N/A	N/A	N/A	Unsuitable	
Clydach to Blaenavon Road (10) , Highway land at	Clydach to Blaenavon Road (10) , Highway land at, Pwll Du, Abergavenny, Monmouthshire	Road/pavement	N/A	N/A	N/A	N/A	Unsuitable	
Clydach to Blaenavon Road (11) , Highway land at	Clydach to Blaenavon Road (11) , Highway land at, Pwll Du, Abergavenny, Monmouthshire	Road/pavement	N/A	N/A	N/A	N/A	Unsuitable	
Clydach to Blaenavon Road (2) , Highway land at	Clydach to Blaenavon Road (2) , Highway land at, Abergavenny, Monmouthshire	Road/pavement	N/A	N/A	N/A	N/A	Unsuitable	
Clydach to Blaenavon Road (3) , Highway land at	Clydach to Blaenavon Road (3) , Highway land at, Abergavenny, Monmouthshire	Road/pavement	N/A	N/A	N/A	N/A	Unsuitable	
Clydach to Blaenavon Road (4) , Highway land at	Clydach to Blaenavon Road (4) , Highway land at, Abergavenny, Monmouthshire	Road/pavement	N/A	N/A	N/A	N/A	Unsuitable	
Clydach to Blaenavon Road (5), Highway land at	Clydach to Blaenavon Road (5), Highway land at, Abergavenny, Monmouthshire	Road/pavement	N/A	N/A	N/A	N/A	Unsuitable	
Clydach to Blaenavon Road (6), Highway land at	Clydach to Blaenavon Road (6), Highway land at, Abergavenny, Monmouthshire	Road/pavement	N/A	N/A	N/A	N/A	Unsuitable	
Clydach to Blaenavon Road (7) , Highway land at	Clydach to Blaenavon Road (7) , Highway land at, Pwll Du, Abergavenny, Monmouthshire	Road/pavement	N/A	N/A	N/A	N/A	Unsuitable	
Clydach to Blaenavon Road (8) , Highway land at	Clydach to Blaenavon Road (8) , Highway land at, Pwll Du, Abergavenny, Monmouthshire	Road/pavement	N/A	N/A	N/A	N/A	Unsuitable	
Clydach to Blaenavon Road (9) , Highway land at	Clydach to Blaenavon Road (9) , Highway land at, Pwll Du, Abergavenny, Monmouthshire	Road/pavement	N/A	N/A	N/A	N/A	Unsuitable	
Clytha Motors, Highway fronting	Clytha Motors, Highway fronting, Merthyr Road, Llanfoist, Abergavenny, Monmouthshire	Road/pavement	N/A	N/A	N/A	N/A	Unsuitable	
Coed Barnett, Highway opposite junction	Coed Barnett, Highway opposite junction, Chepstow, Monmouthshire	Road/pavement	N/A	N/A	N/A	N/A	Unsuitable	

Coed Chambers, Highway at	Coed Chambers, Highway at, Coed y Paen, Pontypool	Road/pavement	N/A	N/A	N/A	N/A	Unsuitable	
Colbost & The Stile, Highway fronting	Colbost & The Stile, Highway fronting, Magor, Caldicot, Monmouthshire	Road/pavement	N/A	N/A	N/A	N/A	Unsuitable	
Coltharts Garage, Highway land opposite	Coltharts Garage, Highway land opposite, St Arvans, Chepstow, Monmouthshire	Road/pavement	N/A	N/A	N/A	N/A	Unsuitable	
Cophill Farm, Highway opposite	Cophill Farm, Highway opposite, B4293, Chepstow, Monmouthshire	Road/pavement	N/A	N/A	N/A	N/A	Unsuitable	
Corbiere and adjacent properties, Land fronting	Corbiere and adjacent properties, Land fronting, Main Road, Undy, Caldicot, Monmouthshire	Road/pavement	N/A	N/A	N/A	N/A	Unsuitable	
Craig View, Highways verge at	Craig View, Highways verge at, Cross Ash, Abergavenny, Monmouthshire, NP7 8	Road/pavement	N/A	N/A	N/A	N/A	Unsuitable	
Craig-fyddlwm, Highway land adjacent	Craig-fyddlwm, Highway land adjacent, Llanelly Hill, Abergavenny, Monmouthshire	Road/pavement	N/A	N/A	N/A	N/A	Unsuitable	
Crick to Shirenewton, Highway at	Crick to Shirenewton, Highway at, Chepstow, Monmouthshire	Road/pavement	N/A	N/A	N/A	N/A	Unsuitable	
Croes Bleddyn Cottages (55 sq m), Highway opposite	Croes Bleddyn Cottages (55 sq m), Highway opposite, Itton, Chepstow, Monmouthshire	Road/pavement	N/A	N/A	N/A	N/A	Unsuitable	
Croes Bleddyn Cottages (30 sq m), Highway opposite	Croes Bleddyn Cottages (30 sq m), Highway opposite, Itton, Chepstow, Monmouthshire	Road/pavement	N/A	N/A	N/A	N/A	Unsuitable	
Cross Inn, Highway land adjacent to	Cross Inn, Highway land adjacent to, 1 Newport Road, Caldicot, Monmouthshire, NP23 5	Road/pavement	N/A	N/A	N/A	N/A	Unsuitable	
Crossway Green, Highway land at	Crossway Green, Highway land at, off Welsh Street, Chepstow, Monmouthshire	Road/pavement	N/A	N/A	N/A	N/A	Unsuitable	
Crossways, (B4245) (840 sq m)Highway opposite	Crossways, (B4245) (840 sq m)Highway opposite, Portskewett, Caldicot, Monmouthshire	Road/pavement	N/A	N/A	N/A	N/A	Unsuitable	
Crossways, (B4245)Highway opposite	Crossways, (B4245)Highway opposite, Portskewett, Caldicot, Monmouthshire	Road/pavement	N/A	N/A	N/A	N/A	Unsuitable	
Crossways, Highway land fronting	Crossways, Highway land fronting, Mathem, Chepstow, Monmouthshire	Road/pavement	N/A	N/A	N/A	N/A	Unsuitable	
Cwm Celyn, Highway land near	Cwm Celyn, Highway land near, Llanelen, Abergavenny, Monmouthshire	Road/pavement	N/A	N/A	N/A	N/A	Unsuitable	
Dan y Deri, (55.26 sq m), Highway verge at	Dan y Deri, (55.26 sq m), Highway verge at, Abergavenny, Monmouthshire, NP7 8	Road/pavement	N/A	N/A	N/A	N/A	Unsuitable	
Dan y Deri, (69.72 sq m), Highway verge at	Dan y Deri, (69.72 sq m), Highway verge at, Abergavenny, Monmouthshire, NP7 8	Road/pavement	N/A	N/A	N/A	N/A	Unsuitable	
Dewstow Road, Highway	Dewstow Road, Highway, Caerwent, Caldicot, Monmouthshire	Road/pavement	N/A	N/A	N/A	N/A	Unsuitable	
Dingestow Sewerage Disposal Tanks	Dingestow Sewerage Disposal Tanks, near Queens Hill, Dingestow, Monmouthshire	Road/pavement	N/A	N/A	N/A	N/A	Unsuitable	
Dinglewood, Highway land adjacent to	Dinglewood, Highway land adjacent to, Crickhowell Road, Gilwern, Abergavenny, Monmouthshire	Road/pavement	N/A	N/A	N/A	N/A	Unsuitable	
Drybridge Park Electricity Sub Station	Drybridge Park Electricity Sub Station, Monmouth, Monmouthshire, NP25 5AS	Road/pavement	N/A	N/A	N/A	N/A	Unsuitable	
Dyffryn Cottages,(north & south side), Highway near	Dyffryn Cottages,(north & south side), Highway near, Grosmont, Monmouth, Monmouthshire	Road/pavement	N/A	N/A	N/A	N/A	Unsuitable	
Eagle House, Highway opposite	Eagle House, Highway opposite, Usk Road, Shirenewton, Chepstow, Monmouthshire	Road/pavement	N/A	N/A	N/A	N/A	Unsuitable	
Eastgate Crescent, Highway verge at	Eastgate Crescent, Highway verge at, Caerwent, Chepstow, Monmouthshire	Road/pavement	N/A	N/A	N/A	N/A	Unsuitable	
Ebenezer Chapel and Oakville, Land between	Ebenezer Chapel and Oakville, Land between, The Square, Magor, Caldicot, Monmouthshire	Road/pavement	N/A	N/A	N/A	N/A	Unsuitable	
Elenmor, Highway fronting	Elenmor, Highway fronting, Govilon, Abergavenny, Monmouthshire	Road/pavement	N/A	N/A	N/A	N/A	Unsuitable	
Estavarny Cottage, Highway fronting	Estavarny Cottage, Highway fronting, Monkswood, Usk, Monmouthshire	Road/pavement	N/A	N/A	N/A	N/A	Unsuitable	
Estavarny Farm Cottage, Highway fronting	Estavarny Farm Cottage, Highway fronting, Monkswood, Usk, Monmouthshire	Road/pavement	N/A	N/A	N/A	N/A	Unsuitable	
Euro House, Highway land fronting	Euro House, Highway land fronting, Bulwark Road, Chepstow, Monmouthshire	Road/pavement	N/A	N/A	N/A	N/A	Unsuitable	
Fairfield Close and Kirlach Close, Highway at	Fairfield Close and Kirlach Close, Highway at, Caldicot, Monmouthshire	Road/pavement	N/A	N/A	N/A	N/A	Unsuitable	
Farthing Hill, Highway opposite	Farthing Hill, Highway opposite, Portskewett, Caldicot, Monmouthshire	Road/pavement	N/A	N/A	N/A	N/A	Unsuitable	
Fedw Cottage, Highway fronting	Fedw Cottage, Highway fronting, Devauden, Chepstow, Monmouthshire	Road/pavement	N/A	N/A	N/A	N/A	Unsuitable	
Ferney Cross, Highway at	Ferney Cross, Highway at, Caldicot, Monmouthshire	Road/pavement	N/A	N/A	N/A	N/A	Unsuitable	Kipling Road
Ferleigh Road, Highway verge at	Ferleigh Road, Highway verge at, Caldicot, Monmouthshire	Road/pavement	N/A	N/A	N/A	N/A	Unsuitable	
Fiddlers Elbow, B4246, Highway at	Fiddlers Elbow, B4246, Highway at, Govilon, Abergavenny, Monmouthshire	Road/pavement	N/A	N/A	N/A	N/A	Unsuitable	
Fiddlers Elbow, Highway near	Fiddlers Elbow, Highway near, Wyesham, Monmouth, Monmouthshire	Road/pavement	N/A	N/A	N/A	N/A	Unsuitable	
Field House, Highway land adjacent to	Field House, Highway land adjacent to, Blackrock, Clydach, Abergavenny, Monmouthshire	Road/pavement	N/A	N/A	N/A	N/A	Unsuitable	Opposite The Unicorn
Flood Alleviation System		Road/pavement	N/A	N/A	N/A	N/A	Unsuitable	
Ford Bridge (1), Highway land adjacent to	Ford Bridge (1), Highway land adjacent to, St Arvans, Chepstow, Monmouthshire	Road/pavement	N/A	N/A	N/A	N/A	Unsuitable	
Ford Bridge (2), Highway land adjacent to	Ford Bridge (2), Highway land adjacent to, St Arvans, Chepstow, Monmouthshire	Road/pavement	N/A	N/A	N/A	N/A	Unsuitable	
Former Penrhos Sewerage Disposal Works	Former Penrhos Sewerage Disposal Works, Church View, Penrhos, Raglan, Monmouthshire	Road/pavement	N/A	N/A	N/A	N/A	Unsuitable	
Former railway Llanfoist Fawr, Land at	Former railway Llanfoist Fawr, Land at, Llanfoist, Abergavenny, Monmouthshire	Road/pavement	N/A	N/A	N/A	N/A	Unsuitable	
Four Winds Bungalow, Highway near	Four Winds Bungulow, Highway near, Monkswood, Usk, Monmouthshire	Road/pavement	N/A	N/A	N/A	N/A	Unsuitable	
Freshfield, Highway fronting	Freshfield, Highway fronting, Berthon Road, Little Mill, Pontypool	Road/pavement	N/A	N/A	N/A	N/A	Unsuitable	
Frondeg, Highway fronting	Frondeg, Highway fronting, Penperlleni, Pontypool, Monmouthshire	Road/pavement	N/A	N/A	N/A	N/A	Unsuitable	
Fronting 6 Monk Street, Highway Land at	Fronting 6 Monk Street, Highway Land at, Abergavenny, Monmouthshire	Road/pavement	N/A	N/A	N/A	N/A	Unsuitable	
Gaerllwyd Farm (1), Highway opposite	Gaerllwyd Farm (1), Highway opposite, New Church, Chepstow, Monmouthshire	Road/pavement	N/A	N/A	N/A	N/A	Unsuitable	
Gaerllwyd Farm (2), Highway opposite	Gaerllwyd Farm (2), Highway opposite, New Church, Chepstow, Monmouthshire	Road/pavement	N/A	N/A	N/A	N/A	Unsuitable	
Garth,Highway near	Garth,Highway near, Crossways, Newcastle, Monmouth, Monmouthshire	Road/pavement	N/A	N/A	N/A	N/A	Unsuitable	
Gay Drian, Highway opposite	Gay Drian, Highway opposite, Hiley Avenue, Gilwern, Abergavenny, Monmouthshire	Road/pavement	N/A	N/A	N/A	N/A	Unsuitable	
Gilwern House, Highway land opposite	Gilwern House, Highway land opposite, Common Road, Gilwern, Abergavenny, Monmouthshire	Road/pavement	N/A	N/A	N/A	N/A	Unsuitable	
Glangrwyney Road , Highway land	Glangrwyney Road , Highway land, Gilwern, Abergavenny, Monmouthshire	Road/pavement	N/A	N/A	N/A	N/A	Unsuitable	
Glanhonddu Close, Highway land adjacent to	Glanhonddu Close, Highway land adjacent to, Pandy, Abergavenny, Monmouthshire	Road/pavement	N/A	N/A	N/A	N/A	Unsuitable	
Glanrhyd House, Highway fronting	Glanrhyd House, Highway fronting, Crickhowell Road, Gilwern, Abergavenny, Monmouthshire	Road/pavement	N/A	N/A	N/A	N/A	Unsuitable	
Glen View and Upper House, Highway land between	Glen View and Upper House, Highway land between, Llwyndu, Abergavenny, Monmouthshire	Road/pavement	N/A	N/A	N/A	N/A	Unsuitable	
Gocket Inn, (1) Highway near	Gocket Inn, (1) Highway near, Lydart, Monmouth, Monmouthshire	Road/pavement	N/A	N/A	N/A	N/A	Unsuitable	
Gocket Inn, (2) Highway near	Gocket Inn, (2) Highway near, Lydart, Monmouth, Monmouthshire	Road/pavement	N/A	N/A	N/A	N/A	Unsuitable	
Gocket Inn, (3) Highway near	Gocket Inn, (3) Highway near, Lydart, Monmouth, Monmouthshire	Road/pavement	N/A	N/A	N/A	N/A	Unsuitable	
Goldwire Lane, Highways verge at	Goldwire Lane, Highways verge at, Monmouth, Monmouthshire, NP25 5AQ	Road/pavement	N/A	N/A	N/A	N/A	Unsuitable	
Gorphwysfa, Highway land adjacent to	Gorphwysfa, Highway land adjacent to, Cae Meldon, Gilwern, Abergavenny, Monmouthshire	Road/pavement	N/A	N/A	N/A	N/A	Unsuitable	
Grange Road, Dancing Hill & St Brides Road, Highway	Grange Road, Dancing Hill & St Brides Road, Highway, Magor, Caldicot, Monmouthshire	Road/pavement	N/A	N/A	N/A	N/A	Unsuitable	
Granville Street, Highway land	Granville Street, Highway land, Monmouth, Monmouthshire	Road/pavement	N/A	N/A	N/A	N/A	Unsuitable	
Great Tre-Rhew, Highway near	Great Tre-Rhew, Highway near, Llanvetherine, Abergavenny, Monmouthshire	Road/pavement	N/A	N/A	N/A	N/A	Unsuitable	
Great Warfield Cottage, Highway near	Great Warfield Cottage, Highway near, Wyesham, Monmouth, Monmouthshire	Road/pavement	N/A	N/A	N/A	N/A	Unsuitable	
Green Cottage, Highway land opposite	Green Cottage, Highway land opposite, Llanwenarth, Abergavenny, Monmouthshire	Road/pavement	N/A	N/A	N/A	N/A	Unsuitable	
Green Street, Highway at	Green Street, Highway at, Chepstow, Monmouthshire	Road/pavement	N/A	N/A	N/A	N/A	Unsuitable	
Grove Avenue Electricity Sub Station	Grove Avenue Electricity Sub Station, Llanfoist, Abergavenny, Monmouthshire, NP23 5	Road/pavement	N/A	N/A	N/A	N/A	Unsuitable	
Grove Avenue, Highway fronting	Grove Avenue, Highway fronting, Llanfoist, Abergavenny, Monmouthshire	Road/pavement	N/A	N/A	N/A	N/A	Unsuitable	
Gwenhalden & The Bays, Highway fronting	Gwenhalden & The Bays, Highway fronting, Chepstow, Monmouthshire	Road/pavement	N/A	N/A	N/A	N/A	Unsuitable	
Gwynfa, Highway land adjacent to	Gwynfa, Highway land adjacent to, Common Road, Gilwern, Abergavenny, Monmouthshire	Road/pavement	N/A	N/A	N/A	N/A	Unsuitable	
Gypsy Crescent, Highway junction at	Gypsy Crescent, Highway junction at, Llanfoist, Abergavenny, Monmouthshire	Road/pavement	N/A	N/A	N/A	N/A	Unsuitable	

Gypsy Lane & B4246, Highway at junction of	Gypsy Lane & B4246, Highway at junction of, Llanfoist, Abergavenny, Monmouthshire	Road/pavement	N/A	N/A	N/A	N/A	Unsuitable	Highway fronting Greenfield
Gypsy Lane, Highway at	Gypsy Lane, Highway at, Llanfoist, Abergavenny, Monmouthshire	Road/pavement	N/A	N/A	N/A	N/A	Unsuitable	
Hatherleigh Terrace, Highway land adjacent to	Hatherleigh Terrace, Highway land adjacent to, Main Road, Gilwern, Abergavenny, Monmouthshire	Road/pavement	N/A	N/A	N/A	N/A	Unsuitable	
Hendre Close Electricity Sub Station	Hendre Close Electricity Sub Station, Monmouth, Monmouthshire	Road/pavement	N/A	N/A	N/A	N/A	Unsuitable	
Henrhiw & Henrhiw Orles, Highway fronting	Henrhiw & Henrhiw Orles, Highway fronting, Monkswood, Usk, Monmouthshire	Road/pavement	N/A	N/A	N/A	N/A	Unsuitable	
Henrhiw, Henrhiw Orles & Equestrian Centre, Highway opposite	Henrhiw, Henrhiw Orles & Equestrian Centre, Highway opposite, Monkswood, Usk, Monmouthshire	Road/pavement	N/A	N/A	N/A	N/A	Unsuitable	
Henrhiw, Highway adjoining	Henrhiw, Highway adjoining, Monkswood, Usk, Monmouthshire	Road/pavement	N/A	N/A	N/A	N/A	Unsuitable	
High Beech Lane & Beech Grove, Highway at junction	High Beech Lane & Beech Grove, Highway at junction, Chepstow, Monmouthshire	Road/pavement	N/A	N/A	N/A	N/A	Unsuitable	
High Trees Road, Highway land at	High Trees Road, Highway land at, Gilwern, Abergavenny, Monmouthshire	Road/pavement	N/A	N/A	N/A	N/A	Unsuitable	
Highfield Close Electricity Sub Station	Highfield Close Electricity Sub Station, Monmouth, Monmouthshire, NP25 3HP	Road/pavement	N/A	N/A	N/A	N/A	Unsuitable	
Highfield Electricity Sub Station	Highfield Electricity Sub Station, Goytre, Abergavenny, Monmouthshire	Road/pavement	N/A	N/A	N/A	N/A	Unsuitable	
Highfield, Highways verge at	Highfield, Highways verge at, Caerwent, Caldicot, Monmouthshire	Road/pavement	N/A	N/A	N/A	N/A	Unsuitable	
Highmeadow Cottage, Highway at	Highmeadow Cottage, Highway at, Buckholt, Monmouth, Monmouthshire	Road/pavement	N/A	N/A	N/A	N/A	Unsuitable	
Highview, Highway land at	Highview, Highway land at, Twyn Allwys Road, Govilon, Abergavenny, Monmouthshire	Road/pavement	N/A	N/A	N/A	N/A	Unsuitable	
Hill Cottage, Highway near	Hill Cottage, Highway near, Cross Ash, Abergavenny, Monmouthshire	Road/pavement	N/A	N/A	N/A	N/A	Unsuitable	
Hill Farm, Wyesham, Land at	Hill Farm, Land at, Wyesham, Monmouth, Monmouthshire, NP25 3TG	Road/pavement	N/A	N/A	N/A	N/A	Unsuitable	
Hollybush Cottage, Highway near	Hollybush Cottage, Highway near, Llantilio Crossenny, Abergavenny, Monmouthshire	Road/pavement	N/A	N/A	N/A	N/A	Unsuitable	
Holmfild Drive Electricity Sub Station	Holmfild Drive Electricity Sub Station, Llandogo, Monmouth, Monmouthshire	Road/pavement	N/A	N/A	N/A	N/A	Unsuitable	
Homestead, Highway fronting	Homestead, Highway fronting, LLanishen, Chepstow, Monmouthshire	Road/pavement	N/A	N/A	N/A	N/A	Unsuitable	
Housing Estate - Trothy Way	Housing Estate - Trothy Way, Llantilio Crossenny, Abergavenny, Monmouthshire	Road/pavement	N/A	N/A	N/A	N/A	Unsuitable	
Howick Farm & The Old Rectory,(1) Highway between	Howick Farm & The Old Rectory,(1) Highway between, Itton, Chepstow, Monmouthshire	Road/pavement	N/A	N/A	N/A	N/A	Unsuitable	
Howick Farm & The Old Rectory,(2) Highway between	Howick Farm & The Old Rectory,(2) Highway between, Itton, Chepstow, Monmouthshire	Road/pavement	N/A	N/A	N/A	N/A	Unsuitable	
Hybank & Lions Gate, Highway between	Hybank & Lions Gate, Highway between, Itton Common, Chepstow, Monmouthshire	Road/pavement	N/A	N/A	N/A	N/A	Unsuitable	
Ifon Quarry, (485 sq m) Highway near	Ifon Quarry, (485 sq m) Highway near, Rogiet, Caldicot, Monmouthshire	Road/pavement	N/A	N/A	N/A	N/A	Unsuitable	
Ifton Road & Caldicot Road, Highway	Ifton Road & Caldicot Road, Highway, Rogiet, Caldicot, Monmouthshire	Road/pavement	N/A	N/A	N/A	N/A	Unsuitable	
Jubilee Way, Highway at	Jubilee Way, Highway at, Caldicot, Monmouthshire	Road/pavement	N/A	N/A	N/A	N/A	Unsuitable	
Kenways, Ambleside & Sierra House, Highway fronting	Kenways, Ambleside & Sierra House, Highway fronting, Magor, Caldicot, Monmouthshire	Road/pavement	N/A	N/A	N/A	N/A	Unsuitable	
Kings Fee Electricity Sub Station	Kings Fee Electricity Sub Station, Monmouth, Monmouthshire, NP25 5BW	Road/pavement	N/A	N/A	N/A	N/A	Unsuitable	
Kings Fee, Highway verge at	Kings Fee, Highway verge at, Monmouth, Monmouthshire, NP25 5BW	Road/pavement	N/A	N/A	N/A	N/A	Unsuitable	
Laburnum Cottage & 7 Berthin Road, Highway between	Laburnum Cottage & 7 Berthin Road, Highway between, Berthin Road, Little Mill, Monmouthshire	Road/pavement	N/A	N/A	N/A	N/A	Unsuitable	
Ladyhill, Highway North East verge at entrance to	Ladyhill, Highway North East verge at entrance to, Usk, Monmouthshire, NP15	Road/pavement	N/A	N/A	N/A	N/A	Unsuitable	
Ladyhill, Highway North South West verge at entrance to	Ladyhill, Highway North South West verge at entrance to, Usk, Monmouthshire, NP15	Road/pavement	N/A	N/A	N/A	N/A	Unsuitable	
Ladywood, Highway verge adjacent to	Ladywood, Highway verge adjacent to, Usk, Monmouthshire, NP15	Road/pavement	N/A	N/A	N/A	N/A	Unsuitable	
Land at Gilbrook Wood		Road/pavement	N/A	N/A	N/A	N/A	Unsuitable	
Land fronting Newport Road	Land fronting Newport Road, Caldicot, Monmouthshire	Road/pavement	N/A	N/A	N/A	N/A	Unsuitable	
Lansdown Drive, Highway land at	Lansdown Drive, Highway land at, Abergavenny, Monmouthshire	Road/pavement	N/A	N/A	N/A	N/A	Unsuitable	
Laurel Crescent, Land fronting	Laurel Crescent, Land fronting, Main Road, Undy, Caldicot, Monmouthshire	Road/pavement	N/A	N/A	N/A	N/A	Unsuitable	
Lewis's Lane, Highway land at	Lewis's Lane, Highway land at, Abergavenny, Monmouthshire	Road/pavement	N/A	N/A	N/A	N/A	Unsuitable	
Lilac Cottage, Highway land adjacent	Lilac Cottage, Highway land adjacent, Darenfelin, Llanelly Hill, Abergavenny, Monmouthshire	Road/pavement	N/A	N/A	N/A	N/A	Unsuitable	
Limetree Avenue, Highway verge at	Limetree Avenue, Highway verge at, Wyesham, Monmouth, Monmouthshire, NP25 3TG	Road/pavement	N/A	N/A	N/A	N/A	Unsuitable	
Linenwell Wood, Highway land at	Linenwell Wood, Highway land at, Tintern, Monmouthshire	Road/pavement	N/A	N/A	N/A	N/A	Unsuitable	
Linenwell Wood, Highway land opposite	Linenwell Wood, Highway land opposite, Tintern, Monmouthshire	Road/pavement	N/A	N/A	N/A	N/A	Unsuitable	
Link Road & Junction of B4293, Highway land	Link Road & Junction of B4293, Highway land, Monmouth, Monmouthshire	Road/pavement	N/A	N/A	N/A	N/A	Unsuitable	
Link Road, Highway land at	Link Road, Highway land at, Monmouth, Monmouthshire	Road/pavement	N/A	N/A	N/A	N/A	Unsuitable	Wonastow Road
Little Cophill, Highway opposite	Little Cophill, Highway opposite, Itton, Chepstow, Monmouthshire	Road/pavement	N/A	N/A	N/A	N/A	Unsuitable	
Little Goetre Cottage, Highway land near	Little Goetre Cottage, Highway land near, Earlswood, Chepstow, Monmouthshire	Road/pavement	N/A	N/A	N/A	N/A	Unsuitable	
Little Mill Village Hall, Highway fronting	Little Mill Village Hall, Highway fronting, Little Mill, Pontypool	Road/pavement	N/A	N/A	N/A	N/A	Unsuitable	
Little Orchard, Highway fronting	Little Orchard, Highway fronting, Llanelly Church Road, Gilwern, Abergavenny, Monmouthshire	Road/pavement	N/A	N/A	N/A	N/A	Unsuitable	
Llan Farm, Highway opposite	Llan Farm, Highway opposite, The Hendre, Monmouth, Monmouthshire	Road/pavement	N/A	N/A	N/A	N/A	Unsuitable	
Llancayo Farm, Highway fronting	Llancayo Farm, Highway fronting, Llancayo, Usk, Monmouthshire	Road/pavement	N/A	N/A	N/A	N/A	Unsuitable	
Llancayo to Usk Road (1) (A471), Highway at	Llancayo to Usk Road (1) (A471), Highway at, Llancayo, Usk, Monmouthshire	Road/pavement	N/A	N/A	N/A	N/A	Unsuitable	
Llancayo to Usk Road (2) (854 sq m), Highway at	Llancayo to Usk Road (2) (854 sq m), Highway at, Llancayo, Usk, Monmouthshire	Road/pavement	N/A	N/A	N/A	N/A	Unsuitable	
Llancayo to Usk Road (3) (2924 sq m), Highway at	Llancayo to Usk Road (3) (2924 sq m), Highway at, Llancayo, Usk, Monmouthshire	Road/pavement	N/A	N/A	N/A	N/A	Unsuitable	
Llanddewi Rhydderch Sewerage Works	Llanddewi Rhydderch Sewerage Works, Llanddewi Rhydderch, Abergavenny, Monmouthshire	Road/pavement	N/A	N/A	N/A	N/A	Unsuitable	
Llanddewi Rhydderch, Highway Land	Llanddewi Rhydderch, Highway Land, Abergavenny, Monmouthshire	Road/pavement	N/A	N/A	N/A	N/A	Unsuitable	
Llanellen Road & Gypsy Lane, Highway at junction of	Llanellen Road & Gypsy Lane, Highway at junction of, Llanfoist, Abergavenny, Monmouthshire	Road/pavement	N/A	N/A	N/A	N/A	Unsuitable	
Llanellen Road, Highway at	Llanellen Road, Highway at, Llanfoist, Abergavenny, Monmouthshire	Road/pavement	N/A	N/A	N/A	N/A	Unsuitable	
Llanerch, Highway land adjacent to	Llanerch, Highway land adjacent to, Common Road, Gilwern, Abergavenny, Monmouthshire	Road/pavement	N/A	N/A	N/A	N/A	Unsuitable	
Llanfoist Refuse Plant Electricity Sub Station	Llanfoist Refuse Plant Electricity Sub Station, Abergavenny, Monmouthshire	Road/pavement	N/A	N/A	N/A	N/A	Unsuitable	
Llangua, Llanhivangel Cruorney & Grosmont, Highway	Llangua, Llanhivangel Cruorney & Grosmont, Highway in old Parish of, Monmouthshire	Road/pavement	N/A	N/A	N/A	N/A	Unsuitable	
Llangwm Village Hall, Highway fronting	Llangwm Village Hall, Highway fronting, Llangwm, Usk, Monmouthshire	Road/pavement	N/A	N/A	N/A	N/A	Unsuitable	
Llanvair Discoed & Caerwent, Highway between	Llanvair Discoed & Caerwent, Highway between, Caerwent, Caldicot, Monmouthshire	Road/pavement	N/A	N/A	N/A	N/A	Unsuitable	
Llanvetherine & Skenfrith, (B4521) Highway between	Llanvetherine & Skenfrith, (B4521) Highway between, Llanvetherine, Abergavenny, Monmouthshire	Road/pavement	N/A	N/A	N/A	N/A	Unsuitable	
Llanwenarth Arms, Highway land adjoining	Llanwenarth Arms, Highway land adjoining, Brecon Road, Crickhowell, Abergavenny, Monmouthshire	Road/pavement	N/A	N/A	N/A	N/A	Unsuitable	
Llanwern Steelworks Access Road (1), Highway	Llanwern Steelworks Access Road (1), Highway, Magor, Caldicot, Monmouthshire	Road/pavement	N/A	N/A	N/A	N/A	Unsuitable	
Llanwern Steelworks Access Road (10), Highway	Llanwern Steelworks Access Road (10), Highway, Magor, Caldicot, Monmouthshire	Road/pavement	N/A	N/A	N/A	N/A	Unsuitable	
Llanwern Steelworks Access Road (11), Highway	Llanwern Steelworks Access Road (11), Highway, Magor, Caldicot, Monmouthshire	Road/pavement	N/A	N/A	N/A	N/A	Unsuitable	
Llanwern Steelworks Access Road (2), Highway	Llanwern Steelworks Access Road (2), Highway, Magor, Caldicot, Monmouthshire	Road/pavement	N/A	N/A	N/A	N/A	Unsuitable	
Llanwern Steelworks Access Road (3), Highway	Llanwern Steelworks Access Road (3), Highway, Magor, Caldicot, Monmouthshire	Road/pavement	N/A	N/A	N/A	N/A	Unsuitable	
Llanwern Steelworks Access Road (4), Highway	Llanwern Steelworks Access Road (4), Highway, Magor, Caldicot, Monmouthshire	Road/pavement	N/A	N/A	N/A	N/A	Unsuitable	
Llanwern Steelworks Access Road (5), Highway	Llanwern Steelworks Access Road (5), Highway, Magor, Caldicot, Monmouthshire	Road/pavement	N/A	N/A	N/A	N/A	Unsuitable	
Llanwern Steelworks Access Road (6), Highway	Llanwern Steelworks Access Road (6), Highway, Magor, Caldicot, Monmouthshire	Road/pavement	N/A	N/A	N/A	N/A	Unsuitable	

Llanwern Steelworks Access Road (7). Highway	Llanwern Steelworks Access Road (7). Highway, Magor, Caldicot, Monmouthshire	Road/pavement	N/A	N/A	N/A	N/A	Unsuitable	
Llanwern Steelworks Access Road (8). Highway	Llanwern Steelworks Access Road (8). Highway, Magor, Caldicot, Monmouthshire	Road/pavement	N/A	N/A	N/A	N/A	Unsuitable	
Llanwern Steelworks Access Road (9). Highway	Llanwern Steelworks Access Road (9). Highway, Magor, Caldicot, Monmouthshire	Road/pavement	N/A	N/A	N/A	N/A	Unsuitable	
Llwyn Franc, Highway land opposite	Llwyn Franc, Highway land opposite, Llanvihangel Crucorney, Abergavenny, Monmouthshire	Road/pavement	N/A	N/A	N/A	N/A	Unsuitable	
LLwyn Melin, Highway verge at	LLwyn Melin, Highway verge at, Clydach, Abergavenny, Monmouthshire	Road/pavement	N/A	N/A	N/A	N/A	Unsuitable	
Llwyn-Celyn, Highway near	Llwyn-Celyn, Highway near, Caerleon, Newport	Road/pavement	N/A	N/A	N/A	N/A	Unsuitable	
Llwynu Lane, Access Road at	Llwynu Lane, Access Road at, Abergavenny, Monmouthshire	Road/pavement	N/A	N/A	N/A	N/A	Unsuitable	
Lower Hardwick Mount Pleasant, Highway land adj	Lower Hardwick Mount Pleasant, Highway land adj, Chepstow, Monmouthshire, Newport	Road/pavement	N/A	N/A	N/A	N/A	Unsuitable	
Lower Weyloed & The Larches, Highway opposite	Lower Weyloed & The Larches, Highway opposite, Shirenewton, Chepstow, Monmouthshire	Road/pavement	N/A	N/A	N/A	N/A	Unsuitable	
Lydart Farm, Highway opposite	Lydart Farm, Highway opposite, Lydart, Monmouth, Monmouthshire	Road/pavement	N/A	N/A	N/A	N/A	Unsuitable	
Lysgobion, Highway near	Lysgobion, Highway near, Penpergwm, Abergavenny, Monmouthshire	Road/pavement	N/A	N/A	N/A	N/A	Unsuitable	
M4 Motorway between Rogiet & Caldicot (1)	M4 Motorway between Rogiet & Caldicot (1)	Road/pavement	N/A	N/A	N/A	N/A	Unsuitable	
M4 Motorway between Rogiet & Caldicot (2)	M4 Motorway between Rogiet & Caldicot (2)	Road/pavement	N/A	N/A	N/A	N/A	Unsuitable	
Maes y Ffin, Highway near	Maes y Ffin, Highway near, Llanthony, Abergavenny, Monmouthshire	Road/pavement	N/A	N/A	N/A	N/A	Unsuitable	
Magistrates & Police Station, Highway to the rear	Magistrates & Police Station, Highway to the rear, Tudor Street, Abergavenny, Monmouthshire	Road/pavement	N/A	N/A	N/A	N/A	Unsuitable	
Magor Brewery B4245, Highway fronting	Magor Brewery B4245, Highway fronting, Magor, Caldicot, Monmouthshire	Road/pavement	N/A	N/A	N/A	N/A	Unsuitable	
Magor Road, (1513 sq m)Highway at	Magor Road, (134 sq m)Highway at, Magor, Caldicot, Monmouthshire	Road/pavement	N/A	N/A	N/A	N/A	Unsuitable	
Magor Road, (5094sq m)Highway at	Magor Road, (2157sq m)Highway at, Magor, Caldicot, Monmouthshire	Road/pavement	N/A	N/A	N/A	N/A	Unsuitable	
Manor House, Highway fronting	Manor House, Highway fronting, A466, Tintern, Monmouthshire	Road/pavement	N/A	N/A	N/A	N/A	Unsuitable	
Manor Way (438 Sq Yards), Highway land at	Manor Way (438 Sq Yards), Highway land at, Portskewett, Caldicot, Monmouthshire	Road/pavement	N/A	N/A	N/A	N/A	Unsuitable	
Manor Way (47 Sq Yards), Highway land at	Manor Way (47 Sq Yards), Highway land at, Portskewett, Caldicot, Monmouthshire	Road/pavement	N/A	N/A	N/A	N/A	Unsuitable	
Manor Way, Highway land at	Manor Way, Highway land at, Portskewett, Caldicot, Monmouthshire	Road/pavement	N/A	N/A	N/A	N/A	Unsuitable	
Manor Way, Highway Support Bank at	Manor Way, Highway Support Bank at, Portskewett, Caldicot, Monmouthshire	Road/pavement	N/A	N/A	N/A	N/A	Unsuitable	
Marchwood & Rydal Mount, Highway Between	Marchwood & Rydal Mount, Highway Between, Chepstow, Monmouthshire	Road/pavement	N/A	N/A	N/A	N/A	Unsuitable	
Marpela, Highway land adjacent to	Marpela, Highway land adjacent to, Common Road, Gilwern, Abergavenny, Monmouthshire	Road/pavement	N/A	N/A	N/A	N/A	Unsuitable	
Mathern & Bulwark Roads, Highway land on corner of	Mathern & Bulwark Roads, Highway land on corner of, Chepstow, Monmouthshire	Road/pavement	N/A	N/A	N/A	N/A	Unsuitable	
Mathern Crescent, Highway land fronting	Mathern Crescent, Highway land fronting, Mathern, Chepstow, Monmouthshire	Road/pavement	N/A	N/A	N/A	N/A	Unsuitable	
Mathern Road, Highway land fronting	Mathern Road, Highway land fronting, Chepstow, Monmouthshire	Road/pavement	N/A	N/A	N/A	N/A	Unsuitable	
Mathern Road, Highway verge at	Mathern Road, Highway verge at, Chepstow, Monmouthshire	Road/pavement	N/A	N/A	N/A	N/A	Unsuitable	
Mathern to Pwllmeyric Road, Highway	Mathern to Pwllmeyric Road, Highway, Mathern, Chepstow, Monmouthshire	Road/pavement	N/A	N/A	N/A	N/A	Unsuitable	
Merthyr Road, Highway Land at	Merthyr Road, Highway Land at, Llanfoist, Abergavenny, Monmouthshire	Road/pavement	N/A	N/A	N/A	N/A	Unsuitable	
Middle Way, Highway at	Middle Way, Highway at, Chepstow	Road/pavement	N/A	N/A	N/A	N/A	Unsuitable	
Mill Cottage/Laurel Cottage, Land fronting	Mill Cottage/Laurel Cottage, Land fronting, Main Road, Undy, Caldicot, Monmouthshire	Road/pavement	N/A	N/A	N/A	N/A	Unsuitable	
Mill Street, Highway at	Mill Street, Highway at, Usk, Monmouthshire	Road/pavement	N/A	N/A	N/A	N/A	Unsuitable	
Mill Street, Highway land fronting	Mill Street, Highway land fronting, Usk, Monmouthshire	Road/pavement	N/A	N/A	N/A	N/A	Unsuitable	
Mill Street, Land at	Mill Street, Land at, Abergavenny, Monmouthshire	Road/pavement	N/A	N/A	N/A	N/A	Unsuitable	
Miskin Court/Park Court, Land fronting	Miskin Court/Park Court, Land fronting, Main Road, Undy, Caldicot, Monmouthshire	Road/pavement	N/A	N/A	N/A	N/A	Unsuitable	
Mitchell Troy Sewerage Disposal Works	Mitchell Troy Sewerage Disposal Works, Rocklea, Mitchell Troy, Monmouth, Monmouthshire	Road/pavement	N/A	N/A	N/A	N/A	Unsuitable	
Mitel, Highway land adjacent to	Mitel, Highway land adjacent to, Mitel Business Park, Portskewett, Caldicot, Monmouthshire	Road/pavement	N/A	N/A	N/A	N/A	Unsuitable	
Mitel, Highway land opposite to	Mitel, Highway land opposite to, Mitel Business Park, Portskewett, Caldicot, Monmouthshire	Road/pavement	N/A	N/A	N/A	N/A	Unsuitable	
Model Cottages, Highway land fronting	Model Cottages, Highway land fronting, Mathern, Chepstow, Monmouthshire	Road/pavement	N/A	N/A	N/A	N/A	Unsuitable	
Monkswood Garage, Highway adjacent	Monkswood Garage, Highway adjacent, Monkswood, Usk, Monmouthshire	Road/pavement	N/A	N/A	N/A	N/A	Unsuitable	
Monmouth to Chepstow Road, Highway land at	Monmouth to Chepstow Road, Highway land at, Tintern, Monmouthshire	Road/pavement	N/A	N/A	N/A	N/A	Unsuitable	
Monnow Bridge, Land at	Monnow Bridge, Land at, Monnow Street, Monmouth, Monmouthshire	Road/pavement	N/A	N/A	N/A	N/A	Unsuitable	
Moss Cottage, Highway land adjacent to	Moss Cottage, Highway land adjacent to, St Arvans, Chepstow, Monmouthshire	Road/pavement	N/A	N/A	N/A	N/A	Unsuitable	
Mount Ballan Bridge (1), Highway land at	Mount Ballan Bridge (1), Highway land at, Near Mitel Business Park, Portskewett, Monmouth, Monmouthshire	Road/pavement	N/A	N/A	N/A	N/A	Unsuitable	
Mount Ballan Bridge (2), Highway land at	Mount Ballan Bridge (2), Highway land at, Near Mitel Business Park, Portskewett, Monmouth, Monmouthshire	Road/pavement	N/A	N/A	N/A	N/A	Unsuitable	
Mount Ballan Bridge (3), Highway land at	Mount Ballan Bridge (3), Highway land at, Near Mitel Business Park, Portskewett, Monmouth, Monmouthshire	Road/pavement	N/A	N/A	N/A	N/A	Unsuitable	
Mount Ballan Bridge (4), Highway land at	Mount Ballan Bridge (4), Highway land at, Near Mitel Business Park, Portskewett, Monmouth, Monmouthshire	Road/pavement	N/A	N/A	N/A	N/A	Unsuitable	
Mount Pleasant, Highway land at	Mount Pleasant, Highway land at, Llanelly Hill, Abergavenny, Monmouthshire	Road/pavement	N/A	N/A	N/A	N/A	Unsuitable	Penffyddlwn
Mount Zion Chapel, Highway fronting	Mount Zion Chapel, Highway fronting, Glascoed, Pontypool	Road/pavement	N/A	N/A	N/A	N/A	Unsuitable	
Mounton House, Land adjoining	Mounton House, Land adjoining, Pwllmeyric, Chepstow, Monmouthshire	Road/pavement	N/A	N/A	N/A	N/A	Unsuitable	
Nant y gem, Highway near	Nant y gem, Highway near, Rockfield, Monmouth, Monmouthshire	Road/pavement	N/A	N/A	N/A	N/A	Unsuitable	
Nant yr Ael-Ias, Highway land adjacent	Nant yr Ael-Ias, Highway land adjacent, Dingestow, Monmouth, Monmouthshire	Road/pavement	N/A	N/A	N/A	N/A	Unsuitable	
Nantyerry House Sewerage Works	Nantyerry House Sewerage Works, Nantyerry, Abergavenny, Monmouthshire, Newport	Road/pavement	N/A	N/A	N/A	N/A	Unsuitable	
Nevill Street, Land	Nevill Street, Land, Abergavenny, Monmouthshire, NP7 5DL	Road/pavement	N/A	N/A	N/A	N/A	Unsuitable	
Neville Hall Hospital, Highway at the rear of	Neville Hall Hospital, Highway at the rear of, Abergavenny, Monmouth	Road/pavement	N/A	N/A	N/A	N/A	Unsuitable	
New House, Highway fronting	New House, Highway fronting, Gwernesney, Usk, Monmouthshire	Road/pavement	N/A	N/A	N/A	N/A	Unsuitable	
New House, Highway opposite	New House, Highway opposite, Gwernesney, Usk, Monmouthshire	Road/pavement	N/A	N/A	N/A	N/A	Unsuitable	
Newhouse, Highway fronting	Newhouse, Highway fronting, Llangwm, Usk, Monmouthshire	Road/pavement	N/A	N/A	N/A	N/A	Unsuitable	
Newton Grange, Highway land adjacent to	Newton Grange, Highway land adjacent to, Mathern, Chepstow, Monmouthshire	Road/pavement	N/A	N/A	N/A	N/A	Unsuitable	
Noddfa, Highway land fronting & adjoining properties	Noddfa, Highway land fronting & adjoining properties, Crickhowell Road, Gilwern, Abergavenny, Monmouthshire	Road/pavement	N/A	N/A	N/A	N/A	Unsuitable	
Norcott, Highway land adjacent to	Norcott, Highway land adjacent to, Common Road, Gilwern, Abergavenny, Monmouthshire	Road/pavement	N/A	N/A	N/A	N/A	Unsuitable	
North Side of Portwall Road, Highway Land at	North Side of Portwall Road, Highway Land at, Chepstow, Monmouthshire	Road/pavement	N/A	N/A	N/A	N/A	Unsuitable	
North View, Highway fronting	North View, Highway fronting, Govilon, Abergavenny, Monmouthshire	Road/pavement	N/A	N/A	N/A	N/A	Unsuitable	
Oak Crescent, Highway verge at	Oak Crescent, Highway verge at, Wyesham, Monmouth, Monmouthshire, NP25 3LW	Road/pavement	N/A	N/A	N/A	N/A	Unsuitable	
Octagonal Stone Seat	Octagonal Stone Seat, Priory Street, Monmouth, Monmouthshire	Road/pavement	N/A	N/A	N/A	N/A	Unsuitable	
Old Dixton Road and A40, Land between	Old Dixton Road and A40, Land between, Monmouth, Monmouthshire	Road/pavement	N/A	N/A	N/A	N/A	Unsuitable	
Old Forge Craft Shop, Highway adjacent	Old Forge Craft Shop, Highway adjacent, Magor, Caldicot, Monmouthshire	Road/pavement	N/A	N/A	N/A	N/A	Unsuitable	
Old Hereford Road Electricity Sub Station	Old Hereford Road Electricity Sub Station, Abergavenny, Monmouthshire	Road/pavement	N/A	N/A	N/A	N/A	Unsuitable	Derwen Way
Old Hereford Road, Highway land at	Old Hereford Road, Highway land at, Abergavenny, Monmouthshire	Road/pavement	N/A	N/A	N/A	N/A	Unsuitable	
Old Hereford Road, Highway verge	Old Hereford Road, Highway verge, Abergavenny, Monmouthshire	Road/pavement	N/A	N/A	N/A	N/A	Unsuitable	

Olsote, Highway land adjacent to	Olsote, Highway land adjacent to, Lower Common, Gilwern, Abergavenny, Monmouthshire	Road/pavement	N/A	N/A	N/A	N/A	Unsuitable	
Onen House, Highway near	Onen House, Highway near, The Onen, Talycoed, Monmouth, Monmouthshire	Road/pavement	N/A	N/A	N/A	N/A	Unsuitable	
Orchard Close Garages, Highway fronting	Orchard Close Garages, Highway fronting, Caldicot, Monmouthshire	Road/pavement	N/A	N/A	N/A	N/A	Unsuitable	
Orchard House/St Govans, Highway land fronting	Orchard House/St Govans, Highway land fronting, Bulwark Road, Chepstow, Monmouthshire	Road/pavement	N/A	N/A	N/A	N/A	Unsuitable	
Osbaston Road, Land fronting	Osbaston Road, Land fronting, Monmouth, Monmouthshire	Road/pavement	N/A	N/A	N/A	N/A	Unsuitable	
Pandy Caravan Park, Highway near	Pandy Caravan Park, Highway near, Pandy, Abergavenny, Monmouthshire	Road/pavement	N/A	N/A	N/A	N/A	Unsuitable	
Pant Farm, (B4269) Highway opposite	Pant Farm, (B4269) Highway opposite, Llanellen, Abergavenny, Monmouthshire	Road/pavement	N/A	N/A	N/A	N/A	Unsuitable	
Park Crescent, Highway at	Park Crescent, Highway at, Abergavenny, Monmouthshire	Road/pavement	N/A	N/A	N/A	N/A	Unsuitable	
Park Road & Pen y Pound, Highway at junction of	Park Road & Pen y Pound, Highway at junction of, Abergavenny, Monmouthshire	Road/pavement	N/A	N/A	N/A	N/A	Unsuitable	
Parkfield, Highway fronting & adjoining properties	Parkfield, Highway fronting & adjoining properties, St Arvans, Chepstow, Monmouthshire	Road/pavement	N/A	N/A	N/A	N/A	Unsuitable	
Parklands, Highway land fronting	Parklands, Highway land fronting, Mathern, Chepstow, Monmouthshire	Road/pavement	N/A	N/A	N/A	N/A	Unsuitable	
Pedestrian Square at The Cross	Pedestrian Square at The Cross, Caldicot, Monmouthshire	Road/pavement	N/A	N/A	N/A	N/A	Unsuitable	
Pen y Cwm, Highway near	Pen y Cwm, Highway near, The Hendre, Monmouth, Monmouthshire	Road/pavement	N/A	N/A	N/A	N/A	Unsuitable	
Pen y Glog Road Sewerage Disposal Works	Pen y Glog Road Sewerage Disposal Works, Llandegfedd, Usk, Monmouthshire	Road/pavement	N/A	N/A	N/A	N/A	Unsuitable	
Pen y Rhiw Sewerage Disposal Works	Pen y Rhiw Sewerage Disposal Works, Llanwenarth, Abergavenny, Monmouthshire	Road/pavement	N/A	N/A	N/A	N/A	Unsuitable	
Pen yr Heol Farm, Highway land opposite	Pen yr Heol Farm, Highway land opposite, Gilwern, Abergavenny, Monmouthshire	Road/pavement	N/A	N/A	N/A	N/A	Unsuitable	
Penbidwal Farmhouse, Highway land adjacent to	Penbidwal Farmhouse, Highway land adjacent to, Penbidwal Lane, Pandy, Abergavenny, Monmouthshire	Road/pavement	N/A	N/A	N/A	N/A	Unsuitable	
Penperleni House, Highway near	Penperleni House, Highway near, Plough Road, Penperleni, Pontypool	Road/pavement	N/A	N/A	N/A	N/A	Unsuitable	
Pentre Farm & Penyrheol Farm, Land between	Pentre Farm & Penyrheol Farm, Land between, Llanwenarth, Abergavenny, Monmouthshire	Road/pavement	N/A	N/A	N/A	N/A	Unsuitable	
Pentre Farm & Trysor, Highway land between	Pentre Farm & Trysor, Highway land between, Llanwenarth, Abergavenny, Monmouthshire	Road/pavement	N/A	N/A	N/A	N/A	Unsuitable	
Pentre Wylan, Highway opposite	Pentre Wylan, Highway opposite, Llantilio Crossenny, Abergavenny, Monmouthshire	Road/pavement	N/A	N/A	N/A	N/A	Unsuitable	
Penygraig Farm, Highway land at	Penygraig Farm, Highway land at, Llanwenarth, Abergavenny, Monmouthshire	Road/pavement	N/A	N/A	N/A	N/A	Unsuitable	
Penyrheol Farm & Pentre Farm, Land between	Penyrheol Farm & Pentre Farm, Land between, Llanwenarth, Abergavenny, Monmouthshire	Road/pavement	N/A	N/A	N/A	N/A	Unsuitable	
Penyrheol Farm, Highway land opposite	Penyrheol Farm, Highway land opposite, Llanwenarth, Abergavenny, Monmouthshire	Road/pavement	N/A	N/A	N/A	N/A	Unsuitable	
Peruana, Highway land adjacent to	Peruana, Highway land adjacent to, Common Road, Gilwern, Abergavenny, Monmouthshire	Road/pavement	N/A	N/A	N/A	N/A	Unsuitable	
Piecefield Avenue & Wye Valley Link Road, Highway between	Piecefield Avenue & Wye Valley Link Road, Highway between, Chepstow, Monmouthshire	Road/pavement	N/A	N/A	N/A	N/A	Unsuitable	
Pill Farm Industrial Estate Sewerage Works	Pill Farm Industrial Estate Sewerage Works, Pill Farm Industrial Estate, Caldicot, Monmouthshire	Road/pavement	N/A	N/A	N/A	N/A	Unsuitable	
Pill Farm Industrial Estate, Highway land	Pill Farm Industrial Estate, Highway land, Caldicot, Monmouthshire	Road/pavement	N/A	N/A	N/A	N/A	Unsuitable	
Plough House & The Birches Highway fronting	Plough House & The Birches Highway fronting, Penperleni, Pontypool, Monmouthshire	Road/pavement	N/A	N/A	N/A	N/A	Unsuitable	
Pont Gam (1), Land at	Pont Gam (1), Land at, Blackrock, Clydach, Abergavenny, Monmouthshire	Road/pavement	N/A	N/A	N/A	N/A	Unsuitable	
Pont Gam (2), Land at	Pont Gam (2), Land at, Blackrock, Clydach, Abergavenny, Monmouthshire	Road/pavement	N/A	N/A	N/A	N/A	Unsuitable	
Poplars Road, Highway land at	Poplars Road, Highway land at, Undy, Caldicot, Monmouthshire	Road/pavement	N/A	N/A	N/A	N/A	Unsuitable	
Porth y gaelod, Highway near	Porth y gaelod, Highway near, Rockfield, Monmouth, Monmouthshire	Road/pavement	N/A	N/A	N/A	N/A	Unsuitable	
Porth y Parc, Highway opposite	Porth y Parc, Highway opposite, LLwyn Du, Abergavenny, Monmouthshire	Road/pavement	N/A	N/A	N/A	N/A	Unsuitable	
Prescoed Cottage, Highway opposite	Prescoed Cottage, Highway opposite, Coed y Paen, Pontypool	Road/pavement	N/A	N/A	N/A	N/A	Unsuitable	
Prescoed Cottages, Highway near	Prescoed Cottages, Highway near, Llanbadoc, Usk, Monmouthshire	Road/pavement	N/A	N/A	N/A	N/A	Unsuitable	
Priory Close, Highway at	Priory Close, Highway at, Caldicot, Monmouthshire	Road/pavement	N/A	N/A	N/A	N/A	Unsuitable	
Public Convenience, Highway fronting	Public Convenience, Highway fronting, Main Road, Gilwern, Abergavenny, Monmouthshire	Road/pavement	N/A	N/A	N/A	N/A	Unsuitable	
Radio Mask Ebbw Vale	Radio Mask Ebbw Vale, Ebbw Vale, Blaenau Gwent	Road/pavement	N/A	N/A	N/A	N/A	Unsuitable	
Raglan Enterprise Park Sewerage Treatment	Raglan Enterprise Park Sewerage Treatment, Chepstow Road, Raglan, Monmouthshire	Road/pavement	N/A	N/A	N/A	N/A	Unsuitable	
Raglan Way, Highway verge at	Raglan Way, Highway verge at, Chepstow, Monmouthshire	Road/pavement	N/A	N/A	N/A	N/A	Unsuitable	
Railway Bridge, Highway near	Railway Bridge, Highway near, Berthin Road, Little Mill, Pontypool	Road/pavement	N/A	N/A	N/A	N/A	Unsuitable	
Rectory Gardens, Land fronting	Rectory Gardens, Land fronting, Main Road, Undy, Caldicot, Monmouthshire	Road/pavement	N/A	N/A	N/A	N/A	Unsuitable	
Redbrook House, Highway land adjacent to	Redbrook House, Highway land adjacent to, Upper Redbrook, Monmouth, Monmouthshire	Road/pavement	N/A	N/A	N/A	N/A	Unsuitable	
Redbrook Road, Highway at	Redbrook Road, Highway at, Near Upper Redbrook, Monmouth, Monmouthshire	Road/pavement	N/A	N/A	N/A	N/A	Unsuitable	
Reddings Farm & River Wye, Highway land between	Reddings Farm & River Wye, Highway land between, Tintern, Monmouthshire	Road/pavement	N/A	N/A	N/A	N/A	Unsuitable	Deadmans Corner
Redwern Farm, Highway opposite	Redwern Farm, Highway opposite, Lydart, Monmouth, Monmouthshire	Road/pavement	N/A	N/A	N/A	N/A	Unsuitable	
Regent Street, Highway access off	Regent Street, Highway access off, Abergavenny, Monmouthshire	Road/pavement	N/A	N/A	N/A	N/A	Unsuitable	
Regent Way, Access road at	Regent Way, Access road at, Chepstow, Monmouthshire	Road/pavement	N/A	N/A	N/A	N/A	Unsuitable	
Robryna, Highway fronting	Robryna, Highway fronting, Berthon Road, Little Mill, Pontypool, Torfaen	Road/pavement	N/A	N/A	N/A	N/A	Unsuitable	
Rogiet Road, B4245, (4803 sq m), Highway	Rogiet Road, B4245, (4803 sq m), Highway, Rogiet, Caldicot, Monmouthshire	Road/pavement	N/A	N/A	N/A	N/A	Unsuitable	
Rose Cottage & White Gates, Highway land fronting	Rose Cottage & White Gates, Highway land fronting, Mathern, Chepstow, Monmouthshire	Road/pavement	N/A	N/A	N/A	N/A	Unsuitable	
Rosedale, Highway near	Rosedale, Highway near, Talycoed, Monmouth, Monmouthshire	Road/pavement	N/A	N/A	N/A	N/A	Unsuitable	
Rosedale, Highway near	Rosedale, Highway near, Lydart, Monmouth, Monmouthshire	Road/pavement	N/A	N/A	N/A	N/A	Unsuitable	
Ross Road/Lower Monk Street, Land at	Ross Road/Lower Monk Street, Land at, Abergavenny, Monmouthshire	Road/pavement	N/A	N/A	N/A	N/A	Unsuitable	
Rother Avenue Electricity Sub Station	Rother Avenue Electricity Sub Station, Abergavenny, Monmouthshire	Road/pavement	N/A	N/A	N/A	N/A	Unsuitable	
Royal Ordnance Sports Club, Highway fronting	Royal Ordnance Sports Club, Highway fronting, Monkwood, Usk, Monmouthshire	Road/pavement	N/A	N/A	N/A	N/A	Unsuitable	
Ruffetts Close, Highway verge at	Ruffetts Close, Highway verge at, Chepstow, Monmouthshire	Road/pavement	N/A	N/A	N/A	N/A	Unsuitable	
Rumble Street, Highway opposite	Rumble Street, Highway opposite, Monkwood, Usk, Monmouthshire	Road/pavement	N/A	N/A	N/A	N/A	Unsuitable	
School House, Highway opposite	School House, Highway opposite, Llangwm, Usk, Monmouthshire	Road/pavement	N/A	N/A	N/A	N/A	Unsuitable	
School House, Highway land opposite	School House, Highway land opposite, Crickhowell Road, Gilwern, Abergavenny, Monmouthshire	Road/pavement	N/A	N/A	N/A	N/A	Unsuitable	
Seasons Close, Highway land near	Seasons Close, Highway land near, Magor, Caldicot, Monmouthshire	Road/pavement	N/A	N/A	N/A	N/A	Unsuitable	
Severn Bridge Social Club, Highway land fronting	Severn Bridge Social Club, Highway land fronting, Bulwark Road, Chepstow, Monmouthshire	Road/pavement	N/A	N/A	N/A	N/A	Unsuitable	
Spoil Heap Craig-fyddlwm, Highway land adjacent to	Spoil Heap Craig-fyddlwm, Highway land adjacent to, Llanelly Hill, Abergavenny, Monmouthshire	Road/pavement	N/A	N/A	N/A	N/A	Unsuitable	
Springfield House (B4293), Highway north & south of	Springfield House (B4293), Highway north & south of, Trelleck, Monmouth, Monmouthshire	Road/pavement	N/A	N/A	N/A	N/A	Unsuitable	
Springfield House (B4293), Highway south of	Springfield House (B4293), Highway south of, Trelleck, Monmouth, Monmouthshire	Road/pavement	N/A	N/A	N/A	N/A	Unsuitable	
St Andrews Walk Sewerage Disposal Works	St Andrews Walk Sewerage Disposal Works, Tredunnoch, Usk, Monmouthshire, NP23 5JG	Road/pavement	N/A	N/A	N/A	N/A	Unsuitable	
St Arvans Court, Highway land fronting & adjacent properties	St Arvans Court, Highway land fronting & adjacent properties, Devauden Road, St Arvans, Chepstow, Monmouthshire	Road/pavement	N/A	N/A	N/A	N/A	Unsuitable	
St Christophers, Highway land adjacent to	St Christophers, Highway land adjacent to, Bulwark Road, Chepstow, Monmouthshire	Road/pavement	N/A	N/A	N/A	N/A	Unsuitable	
St Ewens Road, Land to the rear of	St Ewens Road, Land to the rear of, Chepstow, Monmouthshire, NP16	Road/pavement	N/A	N/A	N/A	N/A	Unsuitable	
St Georges Crescent, Highway verge at	St Georges Crescent, Highway verge at, Abergavenny, Monmouthshire, NP7 6HV	Road/pavement	N/A	N/A	N/A	N/A	Unsuitable	
St Helens Crescent, Highway verge at	St Helens Crescent, Highway verge at, Llanellen, Abergavenny, Monmouthshire	Road/pavement	N/A	N/A	N/A	N/A	Unsuitable	



St Helens Road, Highway at	St Helens Road, Highway at, Abergavenny, Monmouthshire	Road/pavement	N/A	N/A	N/A	N/A	Unsuitable	
St Stephens Close, Highway fronting	St Stephens Close, Highway fronting, Caerwent, Caldicot, Monmouthshire	Road/pavement	N/A	N/A	N/A	N/A	Unsuitable	
St Stephens Place (375.1 sq m) Open Space	St Stephens Place (375.1 sq m) Open Space, Undy, Caldicot, Monmouthshire	Road/pavement	N/A	N/A	N/A	N/A	Unsuitable	
St Teilos Sewerage Works	St Teilos Sewerage Works, Llanarth, Usk, Monmouthshire	Road/pavement	N/A	N/A	N/A	N/A	Unsuitable	Bersondy
St Tewdrics Road, Highway land fronting	St Tewdrics Road, Highway land fronting, Bulwark Road, Chepstow, Monmouthshire	Road/pavement	N/A	N/A	N/A	N/A	Unsuitable	
Standerton, Highway opposite	Standerton, Highway opposite, Lydart, Monmouth, Monmouthshire	Road/pavement	N/A	N/A	N/A	N/A	Unsuitable	
Station Road, Land at	Station Road, Land at, Chepstow, Monmouthshire	Road/pavement	N/A	N/A	N/A	N/A	Unsuitable	
Station Road, Land at (53sqm)	Station Road, Land at (53sqm), Chepstow, Monmouthshire	Road/pavement	N/A	N/A	N/A	N/A	Unsuitable	
Station Road, Highway at	Station Road, Highway at, Govilon, Abergavenny, Monmouthshire	Road/pavement	N/A	N/A	N/A	N/A	Unsuitable	
Staunton Road, Highway at	Staunton Road, Highway at, Monmouth, Monmouthshire	Road/pavement	N/A	N/A	N/A	N/A	Unsuitable	
Stepaside, Highway land fronting	Stepaside, Highway land fronting, Mathern, Chepstow, Monmouthshire	Road/pavement	N/A	N/A	N/A	N/A	Unsuitable	
Stopgate Cottage, Highway adjacent to	Stopgate Cottage, Highway adjacent to, Monkswood, Usk, Monmouthshire	Road/pavement	N/A	N/A	N/A	N/A	Unsuitable	
Strathearn, Highway land near	Strathearn, Highway land near, Mathern, Chepstow, Monmouthshire	Road/pavement	N/A	N/A	N/A	N/A	Unsuitable	
Strathearn, Highway land opposite	Strathearn, Highway land opposite, Mathern, Chepstow, Monmouthshire	Road/pavement	N/A	N/A	N/A	N/A	Unsuitable	
Street Lighting, A465 Heads of the Valley Road	Street Lighting, A465 Heads of the Valley Road, Gilwern Filling Station, Abergavenny, Monmouthshire	Road/pavement	N/A	N/A	N/A	N/A	Unsuitable	
Strongbow & Marten Roads, Highway land fronting	Strongbow & Marten Roads, Highway land fronting, Chepstow, Monmouthshire	Road/pavement	N/A	N/A	N/A	N/A	Unsuitable	
Sunny Side Electricity Sub Station	Sunny Side Electricity Sub Station, Usk, Monmouthshire	Road/pavement	N/A	N/A	N/A	N/A	Unsuitable	
Sunnyside, (B4269)Highway opposite	Sunnyside, (B4269)Highway opposite, Llanellen, Abergavenny, Monmouthshire	Road/pavement	N/A	N/A	N/A	N/A	Unsuitable	
Sunnyside, Highway land fronting & adjacent properties	Sunnyside, Highway land fronting & adjacent properties, Mathern, Chepstow, Monmouthshire	Road/pavement	N/A	N/A	N/A	N/A	Unsuitable	
Swyn Nant, Highway land adjacent to	Swyn Nant, Highway land adjacent to, Rhadyr, Usk, Monmouthshire	Road/pavement	N/A	N/A	N/A	N/A	Unsuitable	
Sylvan View, Highways verge at	Sylvan View, Highways verge at, Tintern, Chepstow, Monmouthshire	Road/pavement	N/A	N/A	N/A	N/A	Unsuitable	
Talherian, Highway land adjacent to	Talherian, Highway land adjacent to, Common Road, Gilwern, Abergavenny, Monmouthshire	Road/pavement	N/A	N/A	N/A	N/A	Unsuitable	
Tallach Du, Highway near	Tallach Du, Highway near, Old Monmouth Road, Abergavenny, Monmouthshire	Road/pavement	N/A	N/A	N/A	N/A	Unsuitable	
Tamarisk, Highway fronting	Tamarisk, Highway fronting, Kiln Road, Llanfoist, Abergavenny, Monmouthshire	Road/pavement	N/A	N/A	N/A	N/A	Unsuitable	
Tan House Public House, Highway land adjacent	Tan House Public House, Highway land adjacent, Shirenewton, Chepstow, Monmouthshire	Road/pavement	N/A	N/A	N/A	N/A	Unsuitable	
Tan Yr Allt, Highway fronting	Tan Yr Allt, Highway fronting, Govilon, Abergavenny, Monmouthshire	Road/pavement	N/A	N/A	N/A	N/A	Unsuitable	
Temple Dors Bend, Highway at	Temple Dors Bend, Highway at, St Arvans, Chepstow, Monmouthshire	Road/pavement	N/A	N/A	N/A	N/A	Unsuitable	
The Avenue Electricity Sub Station	The Avenue Electricity Sub Station, Govilon, Abergavenny, Monmouthshire, NP7	Road/pavement	N/A	N/A	N/A	N/A	Unsuitable	
The Avenue, Highway at	The Avenue, Highway at, Caldicot, Monmouthshire	Road/pavement	N/A	N/A	N/A	N/A	Unsuitable	
The Avenue, Highway verge at	The Avenue, Highway verge at, Govilon, Abergavenny, Monmouthshire, NP7 9PP	Road/pavement	N/A	N/A	N/A	N/A	Unsuitable	
The Bay, Highway land at	The Bay, Highway land at, Tintern, Monmouthshire	Road/pavement	N/A	N/A	N/A	N/A	Unsuitable	
The Brace Barn, Highway land opposite	The Brace Barn, Highway land opposite, Llandenny, Usk, Monmouthshire, NP15	Road/pavement	N/A	N/A	N/A	N/A	Unsuitable	
The Cell, Highway fronting	The Cell, Highway fronting, Redbrook Road, Wyesham, Monmouth, Monmouthshire	Road/pavement	N/A	N/A	N/A	N/A	Unsuitable	
The Chart House, Highway opposite	The Chart House, Highway opposite, Llanvihangel Gobion, Abergavenny, Monmouthshire	Road/pavement	N/A	N/A	N/A	N/A	Unsuitable	
The Chase, Highway land fronting & adjacent properties	The Chase, Highway land fronting & adjacent properties, St Arvans, Chepstow, Monmouthshire	Road/pavement	N/A	N/A	N/A	N/A	Unsuitable	
The Croft, Land fronting	The Croft, Land fronting, Main Road, Undy, Caldicot, Monmouthshire	Road/pavement	N/A	N/A	N/A	N/A	Unsuitable	
The Cross (136 sq m), Highway at	The Cross (136 sq m), Highway at, Caldicot, Monmouthshire	Road/pavement	N/A	N/A	N/A	N/A	Unsuitable	
The Cross (16 sq m), Highway at	The Cross (16 sq m), Highway at, Caldicot, Monmouthshire	Road/pavement	N/A	N/A	N/A	N/A	Unsuitable	
The Cross (185 sq m), Highway at	The Cross (185 sq m), Highway at, Caldicot, Monmouthshire	Road/pavement	N/A	N/A	N/A	N/A	Unsuitable	
The Cross (91 sq m), Highway at	The Cross (91 sq m), Highway at, Caldicot, Monmouthshire	Road/pavement	N/A	N/A	N/A	N/A	Unsuitable	
The Cross Electricity Sub Station	The Cross Electricity Sub Station, Caldicot, Monmouthshire	Road/pavement	N/A	N/A	N/A	N/A	Unsuitable	
The Crosshands (B4293), Highway at	The Crosshands (B4293), Highway at, Devauden, Chepstow, Monmouthshire	Road/pavement	N/A	N/A	N/A	N/A	Unsuitable	
The Dingle Mount Pleasant, Highway land adjoining	The Dingle Mount Pleasant, Highway land adjoining, Chepstow, Monmouthshire	Road/pavement	N/A	N/A	N/A	N/A	Unsuitable	
The Drama Centre, Highway fronting	The Drama Centre, Highway fronting, Abergavenny, Monmouthshire	Road/pavement	N/A	N/A	N/A	N/A	Unsuitable	
The Gables, Highway fronting	The Gables, Highway fronting, Plough Road, Penperleni, Pontypool	Road/pavement	N/A	N/A	N/A	N/A	Unsuitable	
The Gardens, Highway fronting	The Gardens, Highway fronting, Magor, Caldicot, Monmouthshire	Road/pavement	N/A	N/A	N/A	N/A	Unsuitable	
The Grange, Highway adjacent to	The Grange, Highway adjacent to, Merthyr Road, Govilon, Abergavenny, Monmouthshire	Road/pavement	N/A	N/A	N/A	N/A	Unsuitable	
The Hospice, Highway fronting	The Hospice, Highway fronting, A466, Tintern, Monmouthshire	Road/pavement	N/A	N/A	N/A	N/A	Unsuitable	
The Lawns & adjacent properties, Highway fronting	The Lawns & adjacent properties, Highway fronting, Magor, Monmouthshire	Road/pavement	N/A	N/A	N/A	N/A	Unsuitable	
The Mill House, off B4235, Highway near	The Mill House, off B4235, Highway near, Llangwm, Usk, Monmouthshire	Road/pavement	N/A	N/A	N/A	N/A	Unsuitable	
The Nook, Highway fronting	The Nook, Highway fronting, Kiln Road, Llanfoist, Abergavenny, Monmouthshire	Road/pavement	N/A	N/A	N/A	N/A	Unsuitable	
The Nurseries, Highway opposite	The Nurseries, Highway opposite, Wyesham, Monmouth, Monmouthshire	Road/pavement	N/A	N/A	N/A	N/A	Unsuitable	
The Old Corn Mill & Gilwern Garage, Highway land adjacent	The Old Corn Mill & Gilwern Garage, Highway land adjacent to, Gilwern, Abergavenny, Monmouthshire	Road/pavement	N/A	N/A	N/A	N/A	Unsuitable	
The Old Rectory, Highway fronting	The Old Rectory, Highway fronting, Llanelly Church Road, Gilwern, Abergavenny, Monmouthshire	Road/pavement	N/A	N/A	N/A	N/A	Unsuitable	
The Old Rectory, Highway land opposite	The Old Rectory, Highway land opposite, Llanfihangel Ystern Llewern, Monmouthshire	Road/pavement	N/A	N/A	N/A	N/A	Unsuitable	
The Paddock, Highway adjacent to	The Paddock, Highway adjacent to, Shirenewton, Chepstow, Monmouthshire	Road/pavement	N/A	N/A	N/A	N/A	Unsuitable	
The Paddocks, Land fronting	The Paddocks, Land fronting, Main Road, Undy, Caldicot, Monmouthshire	Road/pavement	N/A	N/A	N/A	N/A	Unsuitable	
The Tilla Cottage, Highway land near	The Tilla Cottage, Highway land near, The Tilla, Gilwern, Abergavenny, Monmouthshire	Road/pavement	N/A	N/A	N/A	N/A	Unsuitable	
The Toll House, Highway opposite	The Toll House, Highway opposite, Llangwm, Usk, Monmouthshire	Road/pavement	N/A	N/A	N/A	N/A	Unsuitable	
The Tumble, Highway near	The Tumble, Highway near, Pwll Du, Govilon, Monmouthshire	Road/pavement	N/A	N/A	N/A	N/A	Unsuitable	
The Villas, Highway fronting	The Villas, Highway fronting, Govilon, Abergavenny, Monmouthshire	Road/pavement	N/A	N/A	N/A	N/A	Unsuitable	
Thomas Industrial Units, Highway at	Thomas Industrial Units, Highway at, Off Lower Monk Street, Abergavenny, Monmouthshire	Road/pavement	N/A	N/A	N/A	N/A	Unsuitable	
Thomas Street, Highway at	Thomas Street, Highway at, Chepstow, Monmouthshire	Road/pavement	N/A	N/A	N/A	N/A	Unsuitable	
Thornbury, Highway fronting	Thornbury, Highway fronting, Plough Road, Penperleni, Pontypool	Road/pavement	N/A	N/A	N/A	N/A	Unsuitable	
Tintern Abbey Site, Highway land adjacent to	Tintern Abbey Site, Highway land adjacent to, Tintern, Monmouthshire	Road/pavement	N/A	N/A	N/A	N/A	Unsuitable	
Tintern House, Highway land opposite	Tintern House, Highway land opposite, Tintern, Monmouthshire	Road/pavement	N/A	N/A	N/A	N/A	Unsuitable	
Ton Uchaf Farm, Highway near	Ton Uchaf Farm, Highway near, Llanvapley, Abergavenny, Monmouthshire	Road/pavement	N/A	N/A	N/A	N/A	Unsuitable	
Tramway at Tintern Cross	Tramway at Tintern Cross, Tintern, Monmouthshire	Road/pavement	N/A	N/A	N/A	N/A	Unsuitable	
Tredean Cottages,(1)B4293, Highway fronting	Tredean Cottages,(1)B4293, Highway fronting, Devauden, Chepstow, Monmouthshire	Road/pavement	N/A	N/A	N/A	N/A	Unsuitable	
Tredean Cottages,(2)B4293, Highway fronting	Tredean Cottages,(2)B4293, Highway fronting, Devauden, Chepstow, Monmouthshire	Road/pavement	N/A	N/A	N/A	N/A	Unsuitable	
Tredillion Cottage (1), Highway near	Tredillion Cottage (1), Highway near, Old Monmouth Road, Abergavenny, Monmouthshire	Road/pavement	N/A	N/A	N/A	N/A	Unsuitable	
Tregarn House, Highway at	Tregarn House, Highway at, Magor, Caldicot, Monmouthshire	Road/pavement	N/A	N/A	N/A	N/A	Unsuitable	

Tregarron, Highway land adjacent to	9 Common Road, Gilwern, Abergavenny, Monmouthshire, NP7 0DR	Road/pavement	N/A	N/A	N/A	N/A	Unsuitable	
Trelleck Road (B4293), Highway opposite	Trelleck Road (B4293), Highway opposite, Monmouth, Monmouthshire	Road/pavement	N/A	N/A	N/A	N/A	Unsuitable	
Trinity Street, Highway to the rear of	Trinity Street, Highway to the rear of, Abergavenny, Monmouthshire	Road/pavement	N/A	N/A	N/A	N/A	Unsuitable	
Trostrey House, Highway fronting	Trostrey House, Highway fronting, High Street, Raglan, Monmouthshire	Road/pavement	N/A	N/A	N/A	N/A	Unsuitable	
Trostrey Weir, Land adjacent	Trostrey Weir, Land adjacent, Usk, Monmouthshire	Road/pavement	N/A	N/A	N/A	N/A	Unsuitable	
Trothy Bridge (B4233) (2), Highway at	Trothy Bridge (B4233) (2), Highway at, Llanvapley, Abergavenny, Monmouthshire	Road/pavement	N/A	N/A	N/A	N/A	Unsuitable	
Trothy Cottage (B4233) (1), Highway opposite	Trothy Cottage (B4233) (1), Highway opposite, Llanvapley, Abergavenny, Monmouthshire	Road/pavement	N/A	N/A	N/A	N/A	Unsuitable	
Tryfan, Highway land adjacent to	Tryfan, Highway land adjacent to, Common Road, Gilwern, Abergavenny, Monmouthshire	Road/pavement	N/A	N/A	N/A	N/A	Unsuitable	
Trysor & Pentre Farm (Area 1), Highway land bet	Trysor & Pentre Farm (Area 1), Highway land bet, Llanwenarth, Abergavenny, Monmouthshire	Road/pavement	N/A	N/A	N/A	N/A	Unsuitable	
Trysor & Pentre Farm (Area 2), Highway land bet	Trysor & Pentre Farm (Area 2), Highway land bet, Llanwenarth, Abergavenny, Monmouthshire	Road/pavement	N/A	N/A	N/A	N/A	Unsuitable	
Tudor Street, Highway land at	Tudor Street, Highway land at, Abergavenny, Monmouthshire	Road/pavement	N/A	N/A	N/A	N/A	Unsuitable	
Tump Farm, Highway adjacent to	Tump Farm, Highway adjacent to, Caldicot, Monmouthshire	Road/pavement	N/A	N/A	N/A	N/A	Unsuitable	
Turnpike Cottage, Highway land fronting	Turnpike Cottage, Highway land fronting, St Arvans, Chepstow, Monmouthshire	Road/pavement	N/A	N/A	N/A	N/A	Unsuitable	
Twyn Allwys Road, Highway land at	Twyn Allwys Road, Highway land at, Govilon, Abergavenny, Monmouthshire	Road/pavement	N/A	N/A	N/A	N/A	Unsuitable	
Ty Mawr Road (1), Highway at	Ty Mawr Road (1), Highway at, Gilwern, Abergavenny, Monmouthshire	Road/pavement	N/A	N/A	N/A	N/A	Unsuitable	
Ty Mawr Road (2), Highway at	Ty Mawr Road (2), Highway at, Gilwern, Abergavenny, Monmouthshire	Road/pavement	N/A	N/A	N/A	N/A	Unsuitable	
Ty Mynydd, Highway land near	Ty Mynydd, Highway land near, Llanwenarth, Abergavenny, Monmouthshire	Road/pavement	N/A	N/A	N/A	N/A	Unsuitable	
Ty Newydd, Highway land fronting	Ty Newydd, Highway land fronting, Mathern, Chepstow, Monmouthshire	Road/pavement	N/A	N/A	N/A	N/A	Unsuitable	
Ty Newydd, Highway near	Ty Newydd, Highway near, Glascoed, Pontypool	Road/pavement	N/A	N/A	N/A	N/A	Unsuitable	
Ty Porth, Highway land opposite	Ty Porth, Highway land opposite, Llanellen, Abergavenny, Monmouthshire	Road/pavement	N/A	N/A	N/A	N/A	Unsuitable	
Tythe Barn, Highway near	Tythe Barn, Highway near, Chepstow, Monmouthshire	Road/pavement	N/A	N/A	N/A	N/A	Unsuitable	
Tythe Garage, Highway fronting	Tythe Garage, Highway fronting, Magor, Caldicot, Monmouthshire	Road/pavement	N/A	N/A	N/A	N/A	Unsuitable	
Union Road East, 2, Highway fronting	Union Road East, 2, Highway fronting, Abergavenny, Monmouthshire	Road/pavement	N/A	N/A	N/A	N/A	Unsuitable	
Union Road Garage, Highway opposite	Union Road Garage, Highway opposite, Abergavenny, Monmouthshire	Road/pavement	N/A	N/A	N/A	N/A	Unsuitable	
Union Road West, Highway land at	Union Road West, Highway land at, Abergavenny, Monmouthshire	Road/pavement	N/A	N/A	N/A	N/A	Unsuitable	
Upper Common, Highway adjacent to	Upper Common, Highway adjacent to, Common Road, Gilwern, Abergavenny, Monmouthshire	Road/pavement	N/A	N/A	N/A	N/A	Unsuitable	
Upper House and Glen View, Highway land between	Upper House and Glen View, Highway land between, Llanwenarth, Abergavenny, Monmouthshire	Road/pavement	N/A	N/A	N/A	N/A	Unsuitable	
Usk Drive, Highway	Usk Drive, Highway, Gilwern, Abergavenny, Monmouthshire	Road/pavement	N/A	N/A	N/A	N/A	Unsuitable	
Vauxhall Lane, Highway at	Vauxhall Lane, Highway at, Chepstow, Monmouthshire	Road/pavement	N/A	N/A	N/A	N/A	Unsuitable	
Victoria Street and Princes Street, Land between	Victoria Street and Princes Street, Land between, Abergavenny, Monmouthshire	Road/pavement	N/A	N/A	N/A	N/A	Unsuitable	
Vine Tree Cottage, Highway adjacent to	Vine Tree Cottage, Highway adjacent to, Monkswood, Usk, Monmouthshire	Road/pavement	N/A	N/A	N/A	N/A	Unsuitable	
Vinegar Hill, Highway land at	Vinegar Hill, Highway land at, Undy, Caldicot, Monmouthshire	Road/pavement	N/A	N/A	N/A	N/A	Unsuitable	
Waenllapria, Highway at	Waenllapria, Highway at, Llanelly Hill, Abergavenny, Monmouthshire	Road/pavement	N/A	N/A	N/A	N/A	Unsuitable	Blaen Duar Road
Walbronn Close, Highways verge at	Walbronn Close, Highways verge at, Monmouth, Monmouthshire, NP25 5BG	Road/pavement	N/A	N/A	N/A	N/A	Unsuitable	
Walnut Tree Inn, Highway land adjacent to	Walnut Tree Inn, Highway land adjacent to, Llanddewi Skirrid, Abergavenny, Monmouthshire	Road/pavement	N/A	N/A	N/A	N/A	Unsuitable	
Warren Slade, Highway verge at	Warren Slade, Highway verge at, Bulwark, Chepstow, Monmouthshire	Road/pavement	N/A	N/A	N/A	N/A	Unsuitable	
Wayne Close, Highway fronting	Wayne Close, Highway fronting, LLanishen, Chepstow, Monmouthshire	Road/pavement	N/A	N/A	N/A	N/A	Unsuitable	
Wecha Brook, Highway land adjacent to	Wecha Brook, Highway land adjacent to, Llandenny, Usk, Monmouthshire	Road/pavement	N/A	N/A	N/A	N/A	Unsuitable	Llydiard Melyn Farm, Llandenny
Wesley Gardens, Highway at	Wesley Gardens, Highway at, Devauden, Chepstow, Monmouthshire	Road/pavement	N/A	N/A	N/A	N/A	Unsuitable	
Wesley Way, Highway verge at	Wesley Way, Highway verge at, Devauden, Chepstow	Road/pavement	N/A	N/A	N/A	N/A	Unsuitable	
West End Gardens, Land fronting	West End Gardens, Land fronting, Main Road, Undy, Caldicot, Monmouthshire	Road/pavement	N/A	N/A	N/A	N/A	Unsuitable	
West Lea, Highways verge & retained land at	West Lea, Highways verge at, High Street, Raglan, Monmouthshire, NP15 2EA	Road/pavement	N/A	N/A	N/A	N/A	Unsuitable	
West Winds, Highway fronting	West Winds, Highway fronting, Caldicot, Monmouthshire	Road/pavement	N/A	N/A	N/A	N/A	Unsuitable	
White Gates, Highway land fronting	White Gates, Highway land fronting, Hereford Road, Monmouth, Monmouthshire	Road/pavement	N/A	N/A	N/A	N/A	Unsuitable	
White House Lane, Highway land at	White House Lane, Highway land at, Govilon, Abergavenny, Monmouthshire	Road/pavement	N/A	N/A	N/A	N/A	Unsuitable	Tyla
Whitcroft, Highway adjacent	Whitcroft, Highway adjacent, Monkswood, Usk, Monmouthshire	Road/pavement	N/A	N/A	N/A	N/A	Unsuitable	
Whitcroft, Highway fronting	Whitcroft, Highway fronting, Monkswood, Usk, Monmouthshire	Road/pavement	N/A	N/A	N/A	N/A	Unsuitable	
Whitewick House and adjacent properties, Land fronting	Whitewick House and adjacent properties, Land fronting, Main Road, Undy, Caldicot, Monmouthshire	Road/pavement	N/A	N/A	N/A	N/A	Unsuitable	Land fronting
Willow Close Electricity Sub Station	Willow Close Electricity Sub Station, Caldicot, Monmouthshire, NP26 4NF	Road/pavement	N/A	N/A	N/A	N/A	Unsuitable	
Wonastow Road, Highway verge at	Wonastow Road, Highway verge at, Monmouth, Monmouthshire, NP25 5BW	Road/pavement	N/A	N/A	N/A	N/A	Unsuitable	
Woodbank & Westcot, Highway between	Woodbank & Westcot, Highway between, Itton Common, Chepstow, Monmouthshire	Road/pavement	N/A	N/A	N/A	N/A	Unsuitable	
Woodbank, Highway opposite	Woodbank, Highway opposite, Itton Common, Chepstow, Monmouthshire	Road/pavement	N/A	N/A	N/A	N/A	Unsuitable	
Woodbine Gardens, Highway land opposite	Woodbine Gardens, Highway land opposite, Main Road, Undy, Caldicot, Monmouthshire	Road/pavement	N/A	N/A	N/A	N/A	Unsuitable	
Woodland Bungalow, Highway opposite	Woodland Bungalow, Highway opposite, Llanellen, Abergavenny, Monmouthshire	Road/pavement	N/A	N/A	N/A	N/A	Unsuitable	
Woodland View, Highway land south of	Woodland View, Highway land south of, Cold Harbour, Usk, Monmouthshire	Road/pavement	N/A	N/A	N/A	N/A	Unsuitable	
Woodland View, Highways verge at	Woodland View, Highways verge at, Monmouth, Monmouthshire, NP25 3JW	Road/pavement	N/A	N/A	N/A	N/A	Unsuitable	
Woodlands Close, Highway land fronting	Woodlands Close, Highway land fronting, St Arvans, Chepstow, Monmouthshire	Road/pavement	N/A	N/A	N/A	N/A	Unsuitable	
Woodstock Way, Vehicular access to	Woodstock Way, Vehicular access to, Caldicot, Monmouthshire, NP26 4HY	Road/pavement	N/A	N/A	N/A	N/A	Unsuitable	
Woodville and adjacent properties, Land fronting	Woodville and adjacent properties, Land fronting, Main Road, Undy, Caldicot, Monmouthshire	Road/pavement	N/A	N/A	N/A	N/A	Unsuitable	
Woodwynd Cottage (B4293), Highway fronting	Woodwynd Cottage (B4293), Highway fronting, Devauden, Chepstow, Monmouthshire	Road/pavement	N/A	N/A	N/A	N/A	Unsuitable	
Wordsworth Close Electricity Sub Station	Wordsworth Close Electricity Sub Station, Caldicot, Monmouthshire	Road/pavement	N/A	N/A	N/A	N/A	Unsuitable	
Wye Valley Link Road	Wye Valley Link Road, Chepstow, Monmouthshire	Road/pavement	N/A	N/A	N/A	N/A	Unsuitable	
Wye Valley Link Road (1), A466, Highway	Wye Valley Link Road (1), A466, Highway, Chepstow, Monmouthshire	Road/pavement	N/A	N/A	N/A	N/A	Unsuitable	
Wye Valley Link Road (2), A466, Highway	Wye Valley Link Road (2), A466, Highway, Chepstow, Monmouthshire	Road/pavement	N/A	N/A	N/A	N/A	Unsuitable	
Wye Valley Link Road (3), A466, Highway	Wye Valley Link Road (3), A466, Highway, Chepstow, Monmouthshire	Road/pavement	N/A	N/A	N/A	N/A	Unsuitable	
Wye View, Highway land adjacent to	Wye View, Highway land adjacent to, Tintern, Monmouthshire	Road/pavement	N/A	N/A	N/A	N/A	Unsuitable	
Wyelands View, Highway land fronting	Wyelands View, Highway land fronting, Mathern, Chepstow, Monmouthshire	Road/pavement	N/A	N/A	N/A	N/A	Unsuitable	
Wyesham Road, Highway verge at	Wyesham Road, Highway verge at, Wyesham, Monmouth, Monmouthshire, NP25 5JW	Road/pavement	N/A	N/A	N/A	N/A	Unsuitable	
Y Bwthyn, Highway land fronting	Y Bwthyn, Highway land fronting, Pencroesoped, Abergavenny, Monmouthshire	Road/pavement	N/A	N/A	N/A	N/A	Unsuitable	
Yardro, Highway land adjacent to	Yardro, Highway land adjacent to, Common Road, Gilwern, Abergavenny, Monmouthshire	Road/pavement	N/A	N/A	N/A	N/A	Unsuitable	
Yew Tree Close, Highway fronting	Yew Tree Close, Highway fronting, Caldicot, Monmouthshire	Road/pavement	N/A	N/A	N/A	N/A	Unsuitable	
Yew Tree Cottage(B4293), Highway near	Yew Tree Cottage(B4293), Highway near, Devauden, Chepstow, Monmouthshire	Road/pavement	N/A	N/A	N/A	N/A	Unsuitable	

Yew Tree Cottage, Highway fronting	Yew Tree Cottage, Highway fronting, Monkswood, Usk, Monmouthshire	Road/pavement	N/A	N/A	N/A	N/A	N/A	Unsuitable	
Yew Tree Cottage, Highway land north of	Yew Tree Cottage, Highway land north of, Cold Harbour, Usk, Monmouthshire	Road/pavement	N/A	N/A	N/A	N/A	N/A	Unsuitable	
York Cottage, Highway near	York Cottage, Highway near, Wyesham, Monmouth, Monmouthshire	Road/pavement	N/A	N/A	N/A	N/A	N/A	Unsuitable	
King George V Playing Field, Part of	King George V Playing Field, Part of, Newport Road, Caldicot, Monmouthshire, NP26 5EA	School redevelopment site	N/A	N/A	N/A	N/A	N/A	Unsuitable	
Abergavenny Skate Park	Abergavenny Skate Park, Lower Meadow, Abergavenny, Monmouthshire, NP7 6EJ	Skate park. Community asset.	N/A	N/A	N/A	N/A	N/A	Unsuitable	
Caldicot Skate Park	Caldicot Skate Park, Mill Lane, Caldicot, Monmouthshire, NP26 5XA	Skate park. Community asset.	N/A	N/A	N/A	N/A	N/A	Unsuitable	
Monmouth Skate Park	Monmouth Skate Park, Drybridge Park, Monmouth, Monmouthshire, NP25 5BA	Skate park. Community asset.	N/A	N/A	N/A	N/A	N/A	Unsuitable	Drybridge Skate Park
Oak Grove Solar Farm	Oak Grove Solar Farm, Crick, Portskewett, Monmouthshire, NP26 5UT	Solar Farm	N/A	N/A	N/A	N/A	N/A	Unsuitable	
10H St Pierre - tree planting scheme	St Pierre 10H - tree planting scheme, Estates Section, @Innovation House P O Box 106, Caldicot, Monmouthshire, NP26 5UA	Tree planting scheme	N/A	N/A	N/A	N/A	N/A	Unsuitable	
13 Great House tree planting scheme	Great House 13 tree planting scheme, Caerwent, Caldicot, Monmouthshire, NP26 5UA	Tree planting scheme	N/A	N/A	N/A	N/A	N/A	Unsuitable	
15 Leechpool tree planting scheme	Leechpool 15 tree planting scheme, Leechpool, Portskewett, Caldicot, Monmouthshire, NP26 5UA	Tree planting scheme	N/A	N/A	N/A	N/A	N/A	Unsuitable	
2B Caldicot tree planting scheme	Caldicot 2B tree planting scheme, Church Road, Caldicot, Monmouthshire, NP26 5UA	Tree planting scheme	N/A	N/A	N/A	N/A	N/A	Unsuitable	
Overflow Car Park (100 Spaces) Magor	Overflow Car Park (100 Spaces) Magor, Monmouthshire County Council @ Innovation House P O Box 106, Caldicot, Monmouthshire, NP26 5UA	Used as overflow parking for Investment	N/A	N/A	N/A	N/A	N/A	Unsuitable	
29 Leechpool	29 Leechpool, Portskewett, CALDICOT, NP26 5UA	Woodland.	N/A	N/A	N/A	N/A	N/A	Unsuitable	
Ballan Wood	Ballan Wood, Crick Road, Undy, Caldicot, Monmouthshire, NP26 5UU	Woodland.	N/A	N/A	N/A	N/A	N/A	Unsuitable	
Brooks Farm woodland	Brooks Farm woodland, Chepstow Road, Raglan, Monmouthshire, NP15 2XB	Woodland.	N/A	N/A	N/A	N/A	N/A	Unsuitable	
Copse adj Wagon House, Ifton Hill	Copse adj Wagon House, Ifton Hill, Ifton Hill, Portskewett, Caldicot, NP26 5TT	Woodland.	N/A	N/A	N/A	N/A	N/A	Unsuitable	
Land and Buildings, The Cayo, Shirenewton	Land and Buildings, The Cayo, Shirenewton, NP16 6RL	Woodland.	N/A	N/A	N/A	N/A	N/A	Unsuitable	
Llanddewi Skirrid 6 - tree planting scheme	Llanddewi Skirrid 6 - tree planting scheme, Estates Section, @Innovation House P O Box 106, Caldicot, Monmouthshire, NP26 5UA	Woodland.	N/A	N/A	N/A	N/A	N/A	Unsuitable	
Lower Rodge Wood	Lower Rodge Wood, Estates Section, @Innovation House P O Box 106, Caldicot, Monmouthshire, NP26 5UA	Woodland.	N/A	N/A	N/A	N/A	N/A	Unsuitable	
Priestwood	Priestwood, Estates Section, @Innovation House P O Box 106, Caldicot, Monmouthshire, NP26 5UA	Woodland.	N/A	N/A	N/A	N/A	N/A	Unsuitable	
The Oaks Farm	The Oaks Farm, The Oaks, Shirenewton, Chepstow, Monmouthshire, NP16 6RL	Woodland.	N/A	N/A	N/A	N/A	N/A	N/A	Shirenewton 3/4
Upper Rodge	Upper Rodge, Estates Section, @Innovation House P O Box 106, Caldicot, Monmouthshire, NP26 5UA	Woodland.	N/A	N/A	N/A	N/A	N/A	Unsuitable	
Withybed Wood	Withybed Wood, Main Road, Portskewett, Caldicot, Monmouthshire, NP26 5UA	Woodland.	N/A	N/A	N/A	N/A	N/A	Unsuitable	
Wood at Shirenewton	Wood at Shirenewton, Estates Section, @Innovation House P O Box 106, Caldicot, Monmouthshire, NP26 5UA	Woodland.	N/A	N/A	N/A	N/A	N/A	Unsuitable	
Wood beside M4 at Undy	Wood beside M4 at Undy, Wood north of M4, Knollbury, Magor, Monmouthshire, NP26 5UA	Woodland.	N/A	N/A	N/A	N/A	N/A	Unsuitable	
Woodland - 7100/8400 Great House 2	Woodland - 7100/8400 Great House 2, Estates Section, @Innovation House P O Box 106, Caldicot, Monmouthshire, NP26 5UA	Woodland.	N/A	N/A	N/A	N/A	N/A	Unsuitable	
Woodland - Llanfair Discoed 15	Woodland - Llanfair Discoed 15, Llanfair Discoed, Chepstow, Monmouthshire, NP26 5UA	Woodland.	N/A	N/A	N/A	N/A	N/A	Unsuitable	
Woodland - St Pierre 24H	Woodland - St Pierre 24H, Off A48, Crick, Caldicot, Monmouthshire, NP26 5UA	Woodland.	N/A	N/A	N/A	N/A	N/A	Unsuitable	
Woodland (OS 3911) formerly Great House 2	Woodland (OS 3911) formerly Great House 2, Estates Section, @Innovation House P O Box 106, Caldicot, Monmouthshire, NP26 5UA	Woodland.	N/A	N/A	N/A	N/A	N/A	Unsuitable	
Woodland by A48 - formerly St Pierre 10	Woodland by A48 - formerly St Pierre 10, Crick, Caldicot, Monmouthshire, NP26 5UA	Woodland.	N/A	N/A	N/A	N/A	N/A	Unsuitable	
Penperleni Recreation Ground	Penperleni Recreation Ground, Abergavenny, Monmouthshire, NP4 0AJ							Too small & area of amenity importance	Goytre Recreation Ground
Recreation area Llanfair Discoed	Recreation area Llanfair Discoed, Adj School Court, Llanfair Discoed, Caldicot, Monmouthshire, NP16 6LX							Too Small	
Undy Pt2 (0.20 acres)	Undy Pt2 (0.20 acres), Estates Section, @Innovation House P O Box 106, Caldicot, Monmouthshire, NP26 9AN		0.2 acres					Too Small	Z05

Business Unit Name	Postal Address	Description	Area	Larger than 500sqm?	Inside Flood Zone	Constrained by topography?	Existing Play Space?	Comments
1.85 acres at Dancing Hill, Undy	1.85 Caled Llawr, Dancing Hill, Undy, CALDICOT, NP26 3BY	Agricultural	1.85 acres	1.85 acres	unknown	n/a	n/a	Next stage
10/11/12/Pt13/34/9 Leechpool	Leechpool 10/11/12/Pt13/34/9, Rear of 9 Leechpool Holdings, Crick, Caldicot, Monmouthshire, NP26 5TZ	Agricultural	34.5 acres	34.5 acres	n/a	n/a	n/a	CORE ESTATE
12 acres of land South of Trelleck	12 acres of South of Trelleck, Trelleck, Monmouth, Monmouthshire, NP25 4PF	Agricultural	12 acres	12 acres	n/a	n/a	n/a	Next stage
2A/2B Caldicot	Caldicot 2A/2B, Slough Farm, Caerwent, Caldicot, Monmouthshire, NP26 5NW	Agricultural	53 acres	53 acres	n/a	n/a	n/a	CORE ESTATE
42 Leechpool	Leechpool 42, Lower Leechpool Farm, Portskewett, Caldicot, Monmouthshire, NP26 5UB	Agricultural	37.7 acres	37.7 acres	n/a	n/a	n/a	CORE ESTATE
5 Llanfair Discoed	Llanfair Discoed 5, Llanfair Farm, Llanfair Discoed, Chepstow, Monmouthshire, NP16 6LX	Agricultural	14 acres	14 acres	n/a	n/a	n/a	CORE ESTATE
7.27 acres at Dancing Hill, Undy	7.27, Magor, CALDICOT	Agricultural	7.27 acres	7.27 acres	unknown	n/a	n/a	Next stage
8/9/4 Undy	Undy 8/9/4, Oaklands Farm, Llanfair Discoed, Chepstow, Monmouthshire, NP16 6LX	Agricultural	58.5 acres	58.5 acres	n/a	n/a	n/a	CORE ESTATE
Caerwent 10	Caerwent 10, Slough Farm, Caerwent, Caldicot, Monmouthshire, NP26 5NW	Agricultural	11 acres	11 acres	n/a	n/a	n/a	CORE ESTATE
Caerwent 3A	Caerwent 3A, Slough Farm, Caerwent, Caldicot, Monmouthshire, NP26 5NW	Agricultural	11.3 acres	11.3 acres	n/a	n/a	n/a	CORE ESTATE
OS 4594 at Ifton Hill	OS 4594 at Ifton Hill, Ifton Hill, Caldicot, NP26 5TU	Agricultural	10.77 acres	10.77 acres	Partially	n/a	n/a	CORE ESTATE
OS 5223 at Ty Mawr	OS 5223 at Ty Mawr, Gilwern, Abergavenny, Monmouthshire	Agricultural	8.4 acres	8.4 acres	n/a	n/a	n/a	CORE ESTATE
Pt10/13 Llanfair Discoed	Llanfair Discoed Pt10/13, Lower House Farm, Kemys Commander, Usk, Monmouthshire, NP15 1JU	Agricultural	33.3 acres	33.3 acres	n/a	n/a	n/a	CORE ESTATE
Ty Mawr School Farm	Ty Mawr School Farm, Gilwern, Abergavenny, Monmouthshire, NP7 0EB	Agricultural	29.6 acres	29.6 acres	n/a	n/a	n/a	CORE ESTATE
3 Brooks Farm	3 Brooks Farm, Raglan, Usk, Monmouthshire, NP15 2HX	Agricultural	1112 acres	1112 acres	Partially	n/a	n/a	CORE ESTATE
4 Hayesgate Lane	4 Hayesgate Lane, Mathern, Chepstow, Monmouthshire, NP16 6LJ	Agricultural	94 acres	94 acres	n/a	n/a	n/a	CORE ESTATE
4 Llanddewi Court	4 Llanddewi Court, Llanddewi Skirrid, Abergavenny, Monmouthshire, NP7 8AL	Agricultural	103 acres	104 acres	n/a	Sloped	n/a	CORE ESTATE
5 Llanddewi Court	5 Llanddewi Court, Llanddewi Skirrid, Abergavenny, Monmouthshire, NP7 8AL	Agricultural	137 acres	138 acres	n/a	Sloped	n/a	CORE ESTATE
Greenmeadow Farm	Greenmeadow Farm, Greenmeadow Fm, Hayesgate, Mathern, Chepstow, Monmouthshire, NP16 6LL	Agricultural	89.9 acres	89.9 acres	n/a	n/a	n/a	CORE ESTATE
Ifton Hill Farm	Ifton Hill Farm, Ifton Hill Farm, Portskewett, Caldicot, Monmouthshire, NP26 5TT	Agricultural	137 acres	137 acres	n/a	n/a	n/a	CORE ESTATE
Lower House Farm	Lower House Farm, Lower House Farm, Llanfair Discoed, Chepstow, Monmouthshire, NP16 6LY	Agricultural	117 acres	117 acres	n/a	n/a	n/a	CORE ESTATE
Lower Leechpool Farm	Lower Leechpool Farm, Lower Leechpool Farm, Portskewett, Caldicot, Monmouthshire, NP26 5UB	Agricultural	80.1 acres	80.1 acres	n/a	n/a	n/a	CORE ESTATE
Old Llanishen Farm	Old Llanishen Farm, Old Llanishen Farm, Llangovan, Monmouth, Monmouthshire, NP25 4BU	Agricultural	88 acres	89 acres	n/a	n/a	n/a	CORE ESTATE
Penarth Farm	Penarth Farm, Penarth Farm, Llanishen, Monmouth, Monmouthshire, NP16 6QH	Agricultural	69.9 acres	69.9 acres	n/a	n/a	n/a	CORE ESTATE
Rodge Farm	Rodge Farm, Rodge Farm, Caerwent, Caldicot, Monmouthshire, NP26 5PB	Agricultural	164.5 acres	164.5 acres	n/a	n/a	n/a	CORE ESTATE
Slough Farm	Slough Farm, Slough Farm, Caerwent, Caldicot, Monmouthshire, NP26 5NW	Agricultural	57.2 acres	57.2 acres	n/a	n/a	n/a	CORE ESTATE
3 Llanddewi Court	3 Llanddewi Court, Llanddewi Skirrid, Abergavenny, Monmouthshire, NP7 8AL	Agricultural	37.6 acres	37.6 acres	n/a	n/a	n/a	CORE ESTATE
0.81 acre at Dancing Hill	0.81, Undy, Magor, Monmouthshire	Agricultural	0.81 acres	0.81 acres	n/a	n/a	n/a	Next stage
1.24 hectares at Lower House Farm	1.24, Llanfair Discoed, Chepstow, NP16 6LX	Agricultural	3.06 acres	3.06 acres	n/a	n/a	n/a	CORE ESTATE
5.79 acres at rear of Langley Close Ma	5.79, Magor, Monmouthshire	Agricultural	5.79 acres	5.79 acres	unknown	n/a	n/a	Next stage
Central Farm, 6.02 hectares at	Central Farm, 6.02 hectares at, Greenmeadow Fm, Hayesgate, Mathern, Chepstow, Monmouthshire, NP16 6LL	Agricultural	14.8 acres	14.8 acres	n/a	n/a	n/a	CORE ESTATE
Central Farm, 9.51 hectares at	4 Hayesgate Lane, Mathern, Chepstow, Monmouthshire, NP16 6LJ	Agricultural	23.49 acres	23.49 acres	n/a	n/a	n/a	CORE ESTATE
Central Farm, 9.92 hectares at	Central Farm, 9.92 hectares at, Slough Farm, Caerwent, Caldicot, Monmouthshire, NP26 5NW	Agricultural	24.5 acres	24.5 acres	n/a	n/a	n/a	CORE ESTATE
Land adj Indian Empire restaurant	Land adj Indian Empire restaurant, Portskewett, Caldicot, NP26 5UT	Agricultural	1.9 acres	1.9 acres	n/a	n/a	n/a	CORE ESTATE
OS6954 - 1.64 acres at Caerwent	OS6954 - 1.64 acres at Caerwent, Caerwent, CALDICOT, NP26 5PB	Agricultural	1.64 acres	Too Small	n/a	n/a	n/a	Unsuitable
OS8959 adjacent The Cayo	OS8959 adjacent The Cayo, Red House Lane, Shirenewton, CHEPSTOW, NP16 6RL	Agricultural	0.1 acres	Too small	n/a	n/a	n/a	Unsuitable
Penyffyddlwn Farm	Penyffyddlwn Farm, Llanelly Hill, Abergavenny, Monmouthshire	Agricultural	???	n/a	n/a	Unfavourable topography	n/a	Unsuitable
Racecourse Farm, Land at	Racecourse Farm, Land at, Llanfoist, Abergavenny, Monmouthshire, NP7 9HE	Agricultural	42.9 acres	42.9 acres	Yes	n/a	n/a	CORE ESTATE
Ty Mawr	Ty Mawr, Gilwern, Abergavenny, Monmouthshire, NP25 4RN	Agricultural	8.4 acres	8.4 acres	n/a	n/a	n/a	CORE ESTATE
15/16 Portskewett	Portskewett 15/16, The Close, Portskewett, Caldicot, Monmouthshire, NP26 5SN	Agricultural	3.56 acres	3.56 acres	n/a	n/a	Recreation Area	Unsuitable
4 Caldicot	Caldicot 4, The Pill, Caldicot, Monmouthshire, NP26 5XG	Agricultural	20.2 acres	20.2 acres	Yes	n/a	n/a	Unsuitable
Great House Farm, Land at Caerwent	Great House Farm, Caerwent, Great House Farm 2, Caerwent, Caldicot, NP26 5AS	Agricultural	12.4 acres	12.4 acres	n/a	n/a	n/a	CORE ESTATE
Great House Farm, Land to the North	Great House Farm, Caerwent, Caerwent, Monmouthshire, NP26 5AS	Agricultural	0.5 acres	0.5 acres	n/a	n/a	n/a	CORE ESTATE
Chepstow Road Raglan MUGA	Brooks Farm 2, Brooklands, Raglan, Usk, Monmouthshire, NP15 2HX	Agricultural	3.62 acres	3.62 acres	n/a	MUGA - therefore unsuitable	n/a	Unsuitable
Crown Hill Nursery	Crown Hill Nursery, Crown Hill Nursery, Portskewett, Caldicot, Monmouthshire, NP26 5UU	Agricultural	14.1 acres	14.1 acres	n/a	n/a	n/a	CORE ESTATE
Gemini Nursery	14 Leechpool, Portskewett, Caldicot, Monmouthshire, NP26 5TX	Agricultural	13.2 acres	13.2 acres	n/a	n/a	n/a	CORE ESTATE
Windrush Nursery	Windrush Nursery, Windrush Nursery, Portskewett, Caldicot, Monmouthshire, NP26 5UU	Agricultural	7 acres	8 acres	n/a	n/a	n/a	CORE ESTATE
27H Leechpool (620sqm of land)	Leechpool 27H, 27, Leechpool, Portskewett, Caldicot, Monmouthshire, NP26 4UA	Agricultural	0.15 acres	0.15 acres	n/a	n/a	n/a	CORE ESTATE
Bridge View Farm	Bridge View Farm, Bridge View Farm, Portskewett, Caldicot, Monmouthshire, NP26 5TU	Agricultural	88 acres	88 acres	n/a	n/a	n/a	CORE ESTATE
Broadwell Farm, Mathern	Broadwell Farm, Mathern, Broadwell Farm, Mathern, Chepstow, Monmouthshire, NP16 6LL	Agricultural	79 acres	79 acres	n/a	n/a	n/a	CORE ESTATE
Llanfair Farm	Llanfair Farm, Llanfair Farm, Llanfair Discoed, Chepstow, Monmouthshire, NP16 6LX	Agricultural	27.4 acres	27.4 acres	n/a	n/a	n/a	CORE ESTATE
Mynders Farm	Mynders Farm, Mynders Farm, Shirenewton, Chepstow, Monmouthshire, NP16 6AP	Agricultural	72.1 acres	72.1 acres	n/a	n/a	n/a	CORE ESTATE
Oak Grove Farm	Oak Grove Farm, Oak Grove Farm, Crick, Caldicot, Monmouthshire, NP26 5UT	Agricultural	135 acres	135 acres	n/a	Solar Farm	n/a	Unsuitable
Oaklands Farm	Oaklands Farm, Oaklands Farm, Llanfair Discoed, Chepstow, Monmouthshire, NP16 6LX	Agricultural	96 acres	96 acres	n/a	n/a	n/a	CORE ESTATE
Parkwall Farm	Parkwall Farm, Parkwall Farm, Portskewett, Caldicot, Monmouthshire, NP26 5UT	Agricultural	148 acres	148 acres	n/a	Generally sloped	n/a	CORE ESTATE
Rectory Farm	Rectory Farm, Rectory Farm, Portskewett, Caldicot, Monmouthshire, NP26 5US	Agricultural	123.5 acres	123.5 acres	n/a	n/a	n/a	CORE ESTATE
Wallstones Farm	Wallstones Farm, Wallstones Farm, Ifton Hill, Portskewett, Caldicot, Monmouthshire, NP26 5TT	Agricultural	73.3 acres	73.3 acres	n/a	n/a	n/a	CORE ESTATE
Warren Terrace, Land adjacent	Warren Terrace, Land adjacent, Trelech, Monmouth, Monmouthshire, NP25 4PH	Amenity space	0.08 acres	Too small	n/a	n/a	n/a	Unsuitable
Pen y Clawdd Former Refuse Tip	Llanvihangel Cruorney Former Refuse Tip, Pen y Clawdd, Raglan, Monmouthshire	Former refuse	0.97 acres	0.97 acres	n/a	Unfavourable topography	n/a	Unsuitable
Portskewett Former Refuse Tip	Portskewett Former Refuse Tip, Caldicot, Monmouthshire, NP26 5SA	Former refuse	4.1 acres	4.1 acres	n/a	Woodland	n/a	Unsuitable
Beech Road Playground	Beech Road Playground, Caldicot, Monmouthshire, NP26 4DY	Land	0.6 acres	0.6 acres	n/a	n/a	Childrens Play Area	Unsuitable
Belgrave Road Recreation Ground	Belgrave Road Recreation Ground, Abergavenny, Monmouthshire, NP7 7AD	Land	5.1 acres	5.1 acres	unknown	unknown	Childrens Play area on small g	Next stage?
Blenheim Avenue Play area	Blenheim Avenue Play area, Magor, Caldicot, Monmouthshire, NP26 3NB	Land	1.5 acres	1.5 acres	unknown	n/a	Childrens Play Area - portion c	Next stage
Bulwark Park	Bulwark Park, Rockwood Road, Chepstow, Monmouthshire, NP16 5JQ	Land	4.41 acres	4.41 acres	n/a	Sloped	Childrens Play Area	Unsuitable
Carbonne Close Play Area	Carbonne Close Play Area, Monmouth, Monmouthshire, NP25 5EG	Land	1.5 acres	1.5 acres	unknown	unknown	unknown	Next stage
Children's play area St Stephens Cresc	Children's play area St Stephens Crescent, Govilon, Abergavenny, Monmouthshire	Land	0.3 acres	0.3 acres	n/a	n/a	Childrens Play Area	Unsuitable
Chippenham Mead Playground	Chippenham Mead Playground, Monmouth, Monmouthshire, NP25 3UZ	Land	unknown	unknown	n/a	n/a	Childrens Play Area	Unsuitable
Chippenham Mead Village Green	Chippenham Mead Village Green, Monmouth, Monmouthshire, NP25 3EQ	Land	0.11km	0.11km	Yes	n/a	Playing Fields	Unsuitable
Cross Ash Playing Field	Cross Ash Playing Field, Graig View, Cross Ash, Abergavenny, Monmouthshire, NP7 8PF	Land	0.6 acres	0.6 acres	n/a	Sloped	Playing Field	Unsuitable
Dingestow Playing Field	Dingestow Playing Field, Monmouth, Monmouthshire, NP25 4JH	Land	1.03 acres	1.03 acres	n/a	Sloped	Childrens Play Area	Unsuitable
Drybridge Nature Park	Drybridge Nature Park, Rockfield Road, Monmouth, Monmouthshire	Land	15383 sqm	15383sqm	C1 Flood Risk	n/a	Playing Fields	Unsuitable
Forge Road, Land adjacent to	Forge Road, Land adjacent to, Osbaston, Monmouth, Monmouthshire	Land	Thin area adjacent to highw	Too small	n/a	n/a	n/a	Unsuitable
Former Clydach School, land adjacent	Former Clydach School, land adjacent, Off Heads of the Valley Road, Clydach, Monmouthshire, NP& 0LL	Land		Irregular shape - Too small	n/a	n/a	n/a	Unsuitable
Goldwire Lane Playground	Goldwire Lane Playground, Monmouth, Monmouthshire, NP25 5BG	Land	0.09 acres	Too small	n/a	n/a	n/a	Unsuitable
Grosvenor Road, Land at	Grosvenor Road, Land at, Abergavenny, Monmouthshire, NP7 6AH	Land	unknown	Too Small	n/a	n/a	n/a	Unsuitable
Hardwick Recreation Ground	Hardwick Recreation Ground, Hardwick Avenue, Chepstow, Monmouthshire, NP16 5DJ	Land	4.5 acres	4.5 acres	n/a	n/a	Playing Field / Childrens Play	Unsuitable
Hendre Close Playground	Hendre Close Playground, Monmouth, Monmouthshire, NP25 5AX	Land	0.80 acres	0.80 acres	n/a	n/a	Childrens Play Area	Unsuitable
Lawrence Crescent Amenity Land	Lawrence Crescent Amenity Land, Caerwent, Caldicot, Monmouthshire, NP26 5NS	Land	2234 sqm	2234 sqm	n/a	n/a	Childrens Play Area	Unsuitable
Lawrence Crescent Play area	Lawrence Crescent Play area, Caerwent, Caldicot, Monmouthshire, NP26 5NS	Land	0.55 acres	0.55 acres	n/a	n/a	Half protected amenity space.	Next stage
Linda Vista Gardens	Linda Vista Gardens, Tudor Street, Abergavenny, Monmouthshire, NP7 5DL	Land	12097sqm	12097sqm	AN 2 Flood Zone	n/a	N/A	Unsuitable

Llanellen King George Playing Fields	Llanellen, Llanellen, Abergavenny, Monmouthshire, NP7 9HN	Land	1.82 acres	1.82 acres	n/a	n/a	Playing Fields	Unsuitable
Llangybi Play Ground	Llangybi Play Ground, St Cybi Avenue, Llangybi, Usk, Monmouthshire, NP15 1TT	Land	0.65 acres	0.65 acres	n/a	n/a	Childrens Play Area	Unsuitable
Llantillio Pertholey Recreation Ground	Llantillio Pertholey Recreation Ground, Off Gwent Road, Mardy, Abergavenny, Monmouthshire	Land	unknown	unknown	n/a	n/a	Childrens Play Area / Playing	Unsuitable
Llanvapley Recreation Ground	Llanvapley Recreation Ground, Abergavenny, Monmouthshire	Land	4.47 acres	4.47 acres	Yes	n/a	Playing Fields	Unsuitable
Magor Recreation Ground	Magor Recreation Ground, Near Sycamore Terrace, Magor, Monmouthshire	Land	1.49 acres	1.49 acres	Partially	n/a	n/a	Three Fields Site, therefore unsuitable
Main Road , Land at	Main Road , Land at, Undy, Magor, Monmouthshire, NP26 3EH	Land	n/a	n/a	n/a	n/a	n/a	Three Fields Site, therefore unsuitable
Monmouth Road, Land at	Monmouth Road, Land at, Usk, Monmouthshire	Land	258sqm	Too small	unknown	unknown	unknown	Unsuitable
Old Abergavenny Road, Land at	Old Abergavenny Road, Land at, Pencroesop, Abergavenny, Monmouthshire, NP7 9EL	Land	unknown	Too Small	n/a	n/a	n/a	Unsuitable
Old Hereford Road Playing Field	Old Hereford Road Playing Field, Abergavenny, Monmouthshire, NP7 6EL	Land	1.42 acres	1.42 acres	n/a	n/a	Childrens Play Area	Unsuitable
Penperlleni Recreation Ground	Penperlleni Recreation Ground, Abergavenny, Monmouthshire, NP4 0AJ	Land	1.09 acres	1.09 acres	n/a	n/a	Childrens Play Area	Unsuitable
Picnic Site-Beech Hill	Picnic Site-Beech Hill, Chainbridge Road, Usk, Monmouthshire, NP15 1PP	Land	unknown	Too small	n/a	n/a	n/a	Unsuitable
Picnic Site-Newbridge on Usk	Picnic Site-Newbridge on Usk, Off A449, Llantrissant, Usk, Monmouthshire, NP7 0EB	Land	2.9 acres	2.9 acres	n/a	n/a	n/a	Unsuitable - woodland
Recreation area Llanfair Discoed	Recreation area Llanfair Discoed, Adj School Court, Llanfair Discoed, Caldicot, Monmouthshire, NP16 6L	Land	375 sqm	Too small	n/a	n/a	n/a	Unsuitable
Roman Park View Play Area	Roman Park View Play Area, Trelleck, Monmouth, Monmouthshire, NP25 4RB	Land	0.47 acres	0.47 acres	n/a	n/a	Childrens Play Area	Unsuitable
Strongbow Road Play Area	Strongbow Road Play Area, Chepstow, Monmouthshire	Land	2.1 acres	2.1 acres	unknown	unknown	unknown	Next stage
Sycamore Terrace Play Area	Sycamore Terrace Play Area, Magor, Monmouthshire, NP26 3ET	Land	0.47 acres	0.47 acres	n/a	n/a	Childrens Play Area	Unsuitable
The Bryn Play Area	The Bryn Play Area, Abergavenny, Monmouthshire, NP7 9AH	Land	2.6 acres	2.6 acres	Yes	n/a	Childrens Play Area	Unsuitable
The Quest Portskewett Playing Field	The Quest Portskewett Playing Field, Caldicot, Monmouthshire, NP26 5PR	Land	7443 sqm	7443 sqm	n/a	n/a	Childrens Play Area/Playing F	Unsuitable
Thornwell Football Pitch	Thornwell Football Pitch, Denbigh Drive, Chepstow, Monmouthshire	Land	5.21 acres	5.21 acres	n/a	n/a	Playing Fields	Unsuitable
Underhill Playing Field Children's Play	Underhill Playing Field Children's Play Area, Abergavenny, Monmouthshire, NP7 6DT	Land	unknown	unknown	n/a	n/a	Childrens Play Area	Unsuitable
Union Road Playground	Union Road Playground, Abergavenny, Monmouthshire	Land	0.35 acres	0.35 acres	n/a	n/a	Childrens Play Area	Unsuitable
Woodland View Play Area	Woodland View Play Area, Monmouth, Monmouthshire, NP25 3JW	Land	0.59 acres	0.59 acres	n/a	n/a	Childrens Play Area.	Unsuitable
Portal Road, Land at	Portal Road, Land at, Monmouth, Monmouthshire	Land. Declared	1.29 acres	Development Site. Declared Surpl	n/a	n/a	n/a	Unsuitable
Forge Hammer Inn, Land near	Forge Hammer Inn, Land near, Heads of the Valley Road, Gilwern, Abergavenny, Monmouthshire, NP7	Land?	unknown	Too small	n/a	n/a	n/a	Unsuitable
Severn Tunnel Junction, Land & former	Severn Tunnel Junction, Land & former sidings at, Rogiet, Caldicot, Monmouthshire, NP26 3WF	Land?	29 acres	29 acres	Yes - C1 Flood Zone	n/a	n/a	Unsuitable
63 Tudor Street, Land adjacent to	Tudor Street, Land adjacent to 63, Abergavenny, Monmouthshire, NP7 5DL	Public Open	185 sqm	Too small	n/a	n/a	n/a	Unsuitable
A4077 Crickhowell Road (2849 sq m),	A4077 Crickhowell Road (2849 sq m), Land, Gilwern, Abergavenny, Monmouthshire, NP7 0EH	Public Open	2849 sqm	2849 sqm	n/a	n/a	Woodland	Unsuitable
Abergavenny Castle, Land adjacent	Abergavenny Castle, Land adjacent, Mill Street, Abergavenny, Monmouthshire	Public Open	?	Public site. Castle grounds	n/a	n/a	n/a	Unsuitable
Alcove Wood Open Space (1106 sqm)	Alcove Wood Open Space (1106 sqm), Bayfield, Chepstow, Monmouthshire, NP16 6DT	Public Open	1106 sqm	1106 sqm	n/a	n/a	Childrens Play Area	Unsuitable
Alcove Wood Open Space (670.6 sqm)	Alcove Wood Open Space (670.6 sqm), Bayfield, Chepstow, Monmouthshire, NP16 6DT	Public Open	670 sqm	670 sqm	n/a	n/a	Childrens Play Area	Unsuitable
Alice Crescent Public Open Space 166	Alice Crescent Public Open Space 1668 sq m, Chepstow, Monmouthshire, NP16 5SW	Public Open	0.41 acres	0.41 acres	unknown	Flat	n/a	Next stage
Apple Avenue Public Open Space	Apple Avenue Public Open Space, Undy, Caldicot, Monmouthshire, NP26 3QF	Public Open	384 sqm	Too small	n/a	n/a	n/a	Unsuitable
Ash Grove Public Open Space	Ash Grove Public Open Space, Caldicot, Monmouthshire, NP26 4NG	Public Open	895 sqm	895 sqm	n/a	Flat	n/a	Next stage
Baker Street Open Space	Baker Street Open Space, Abergavenny, Monmouthshire, NP7 5BB	Public Open	372 sqm	Too small	n/a	n/a	n/a	Unsuitable
Barn Owl Road Open Space	Barn Owl Road Open Space, Rogiet, Caldicot, Monmouthshire, NP26 3UL	Public Open	731 sqm	Irregular shape - Too small	n/a	n/a	n/a	Unsuitable
Barnets Wood Open Space (408.7sqm)	Barnets Wood Open Space (408.7sqm), Bayfield, Chepstow, Monmouthshire, NP16 5TN	Public Open	0.1 acres	408 sqm	na	n/a	n/a	Unsuitable
Barnets Wood Open Space (530.1sqm)	Barnets Wood Open Space (530.1sqm), Bayfield, Chepstow, Monmouthshire, NP16 5TN	Public Open	530 sqm	Too small - irregular shape prevent	n/a	n/a	n/a	Unsuitable
Bay Tree Lane (4505 sq m) Open Spa	Bay Tree Lane (4505 sq m) Open Space, Abergavenny, Monmouthshire, NP7 5JW	Public Open	4505 sqm	4505 sqm	n/a	n/a	Play Area	Unsuitable
Bayfield Wood Close Open Space (155	Bayfield Wood Close Open Space (155.2 sqm), Bayfield, Chepstow, Monmouthshire, NP16 6FB	Public Open	0.03 acres	Too small	n/a	n/a	n/a	Unsuitable
Bayfield Wood Close Open Space (727	Bayfield Wood Close Open Space (727.5 sqm), Bayfield, Chepstow, Monmouthshire, NP16 6FB	Public Open	727 sqm	727 sqm	n/a	n/a	Childrens Play Area	Unsuitable
Bayfield Wood playground & Open Spa	Bayfield Wood playground & Open Space (6763sqm), Bayfield, Chepstow, Monmouthshire, NP16 6FB	Public Open	1.6 acres	1.6 acres	n/a	n/a	Childrens Play Area	Unsuitable
Beaupreau Place Open Space	Beaupreau Place Open Space, Abergavenny, Monmouthshire, NP7 5LZ	Public Open	5493 sqm	5493 sqm	Yes	n/a	n/a	Unsuitable
Beaupreau Place Public Open Space	Beaupreau Place Public Open Space, Abergavenny, Monmouthshire, NP7 5LZ	Public Open	1.53 acres	1.53 acres	unknown	n/a	n/a	Next stage
Berryfield Close Open Space	Berryfield Close Open Space, Osbaston, Monmouth, Monmouthshire, NP25 3JG	Public Open	1185 sqm	1185 sqm	n/a	n/a	n/a	Next stage
Bigham Close (1233 sq m) Open Spac	Bigham Close (1233 sq m) Open Space, Monmouth, Monmouthshire, NP25 5DP	Public Open	1233 sqm	1233 sqm	unknown	Planting	n/a	Unsuitable
Bigham Close Public Open Space	Bigham Close Public Open Space, Monmouth, Monmouthshire, NP25 5DP	Public Open	1278 sqm	1278 sqm	unknown	n/a	n/a	Next stage
Birbeck Road Open Space	Birbeck Road Open Space, Caldicot, Monmouthshire, NP26 4DX	Public Open	?	Too small. Residential street	n/a	n/a	n/a	Unsuitable
Birch Close Open Space	Birch Close Open Space, Undy, Magor, Monmouthshire, NP26 3LW	Public Open	160 sqm	Too small	n/a	n/a	n/a	Unsuitable
Bishops Close (4277 sq m) Public Ope	Bishops Close (4277 sq m) Public Open Space, Chepstow, Monmouthshire, NP16 5TE	Public Open	1.05 acres	1.05 acres	unknown	Sloped in various places. Potential	n/a	Next stage
Blenheim Avenue Public Open Space	Blenheim Avenue Public Open Space, Magor, Caldicot, Monmouthshire, NP26 3NB	Public Open	1.56 acres	1.56 acres	n/a	n/a	Play Area	Unsuitable
Blestium Drive Open Space, Usk, Mon	Blestium Drive Open Space, Usk, Monmouthshire	Public Open	445 sqm	Too small	n/a	n/a	n/a	Unsuitable
Blethyn Close Open Space	Blethyn Close Open Space, Shirenewton, Chepstow, Monmouthshire, NP16 6SW	Public Open	14466 sqm	14466 sqm	n/a	n/a	n/a	Next stage
Briar Close Open Space	Briar Close Open Space, Undy, Magor, Monmouthshire, N26 3LQ	Public Open	308 sqm	Too small	n/a	n/a	n/a	Unsuitable
Broadstone Terrace/Rocks Close Oper	Broadstone Terrace/Rocks Close Open Space, Catbrook, Monmouth, Monmouthshire, NP16 6NE	Public Open	?	Residential street	n/a	n/a	n/a	Unsuitable
Brookside Open Space	Brookside Open Space, Nedderm Way, Caldicot, Monmouthshire, NP26 4NJ	Public Open	14539 sqm	14539 sqm	unknown	unknown	unknown	Next stage
Brynawr Estate, Filter Bed & Amenity L	Brynawr Estate, Filter Bed & Amenity Land, Cwmyoy, Abergavenny, Monmouthshire, NP7 7ND	Public Open	3037 sqm	3037 sqm	n/a	Woodland	n/a	Unsuitable
Brynteg Place Amenity Land	Brynteg Place Amenity Land, Little Mill, Pontypool, Torfaen, NP4 0HA	Public Open	258 sqm	Too small	n/a	n/a	n/a	Unsuitable
Budden Crescent Open Space	Budden Crescent Open Space, Caldicot, Monmouthshire, NP26 4QB	Public Open	233 sqm	Too small	n/a	n/a	n/a	Unsuitable
Bulwark Road Open Space	Bulwark Road Open Space, Caldicot, Monmouthshire, NP16 5JQ	Public Open	457 sqm	Too small	n.a	n/a	n/a	Unsuitable
Burrium Gate Open Space	Burrium Gate Open Spce, Usk, Monmouthshire	Public Open	728 sqm	728 sqm	Yes	n/a	n/a	Unsuitable
Bushy Close, Land at	Bushy Close, Land at, Portskewett, Caldicot, Monmouthshire, NP26 5TR	Public Open	1019 sqm	Irregular shape - Too small	n/a	n/a	n/a	Unsuitable
Buzzard Close Open Space	Buzzard Close Open Space, Monmouth, Monmouthshire, NP26 3UY	Public Open	456 sqm	Too small	n/a	n/a	n/a	Unsuitable
Cadoc Close (110.5 sq m) Open Space	Cadoc Close (110.5 sq m) Open Space, Caerwent, Caldicot, Monmouthshire, NP26 4QT	Public Open	110sqm	Too small	n/a	n/a	n/a	Unsuitable
Cadoc Close (82.74 sq m) Open Space	Cadoc Close (82.74 sq m) Open Space, Caerwent, Caldicot, Monmouthshire, NP26 4QT	Public Open	82sqm	Too small	na	n/a	n/a	Unsuitable
Cae Derw Public Open Space (1130sq	Cae Derw Public Open Space (1130sqm), Gilwern, Abergavenny, Monmouthshire, NP7 0BJ	Public Open	0.27 acres	1130sqm	n/a	n/a	n/a	Next stage
Cae Derw Public Open Space (701 sq	Cae Derw Public Open Space (701 sqm), Gilwern, Abergavenny, Monmouthshire, NP7 0BJ	Public Open	0.17 acres	701 sqm	n/a	n/a	n/a	Next stage
Cae Melin (1104 sq m) Open Space	Cae Melin (1104 sq m) Open Space, Little Mill, Pontypool, NP4 0HX	Public Open	0.27 acres	1104 sqm	n/a	n/a	Childrens Play Area	Unsuitable
Cae-pen-y-dre Close, Land at	Cae-pen-y-dre Close, Land at, Abergavenny, Monmouthshire, NP7 5UR	Public Open	1422 sqm	1422 sqm	n/a	Sloped - planting	n/a	Unsuitable
Caerwent Lane (3615 sq m) Public Ope	Caerwent Lane (3615 sq m) Public Open Space, Chepstow, Monmouthshire, NP16 5TQ	Public Open	0.89 acres	unknown	unknown	unknown	unknown	Next Stage
Caerwent Lane (69.22sqm) Open Spa	Caerwent Lane (69.22sqm) Open Space, Thornwell, Chepstow, Monmouthshire, NP16 5TQ	Public Open	0.01 acres	Too small	n/a	n/a	n/a	Unsuitable
Caldicot Levels, Land forming part of	Caldicot Levels, Land forming part of, Sudbrook, Caldicot, Monmouthshire, NP26 5TW	Public Open	23 acres	23 acres	Yes	n/a	n/a	Unsuitable
Cappers Place Amenity Land	Cappers Place Amenity Land, Monmouth, Monmouthshire, NP25 5AL	Public Open	499 sqm	Too small	Public Open	n/a	n/a	Unsuitable
Cassia Drive Open Space	Cassia Drive Open Space, Usk, Monmouthshire	Public Open	0.5 acres	0.5 acres	n/a	n/a	Play Area	Unsuitable
Castle Wood Open Space (678.1sqm)	Castle Wood Open Space (678.1sqm), Bayfield, Chepstow, Monmouthshire, NP16 5TZ	Public Open	0.16 acres	678 sqm	n/a	n/a	Childrens Play Area	Unsuitable
Castle Meadows, Land at	Castle Meadows, Land at, Abergavenny, Monmouthshire, NP7 7RZ	Public Open	49 acres	49 acres	Yes	n/a	n/a	Unsuitable
Castle Oak (1154 sq m) Open Space	Castle Oak (1154 sq m) Open Space, Usk, Monmouthshire, NP15 1SG	Public Open	1154 sqm	1154 sqm	Yes	n/a	n/a	Unsuitable
Castle Oak (842.9 sq m) Open Space	Castle Oak (842.9 sq m) Open Space, Usk, Monmouthshire, NP15 1SG	Public Open	842 sqm	842 sqm	n/a	n/a	n/a	Next stage
Caxton Court Public Open Space	Caxton Court Public Open Space, Monmouth, Monmouthshire, NP25 5DJ	Public Open	305 sqm	Too small	n/a	n/a	n/a	Unsuitable
Charles Edwards Close (661.4 sq m) O	Charles Edwards Close (661.4 sq m) Open Space, Llanfoist, Abergavenny, Monmouthshire, NP7 9NQ	Public Open	661 sqm	Too small - footpath and bus stop	n/a	n/a	n/a	Unsuitable
Chaucer Way Public Open Space	Chaucer Way Public Open Space, Osbaston, Monmouth, Monmouthshire, NP25 3NR	Public Open	144 sqm	Too small	n/a	n/a	n/a	Unsuitable
Chepstow Road Open Space	Chepstow Road Open Space, Trellech, Monmouth, Monmouthshire, NP25 4PE	Public Open	253 sqm	Too small	n/a	n/a	n/a	Unsuitable

\*Middle of residential area so not appropriate, but ticks criteria

Woodland

Access

Chestnut Close open Space	Chestnut Close open Space, Magor, Caldicot, Monmouthshire, NP7 5JZ	Public Open	48 sqm	Too small	n/a	n/a	n/a	Unsuitable
Chestnut Drive (1270 sq m) Open Space	Chestnut Drive (1270 sq m) Open Space, Rogiet, Caldicot, Monmouthshire, NP7 5JZ	Public Open	1270 sqm	1270 sqm	n/a	n/a	n/a	Next stage
Chestnut Drive (1423 sq m) Open Space	Chestnut Drive (1423 sq m) Open Space, Abergavenny, Monmouthshire, NP7 5JZ	Public Open	1423 sqm	1423 sqm	n/a	Sloped	n/a	Unsuitable
Chestnut Drive (180 sq m) Open Space	Chestnut Drive (180 sq m) Open Space, Rogiet, Caldicot, Monmouthshire, NP7 5JZ	Public Open	180sqm	Too Small	n/a	n/a	n/a	Unsuitable
Chestnut Drive (268.2 sq m) Open Space	Chestnut Drive (268.2 sq m) Open Space, Rogiet, Caldicot, Monmouthshire, NP7 5JZ	Public Open	268sqm	Too Small	n/a	n/a	n/a	Unsuitable
Chestnut Drive (703 sq m) Open Space	Chestnut Drive (703 sq m) Open Space, Rogiet, Caldicot, Monmouthshire, NP7 5JZ	Public Open	703 sqm	703 sqm	n/a	n/a	n/a	Next stage
Church Rise Public Open Space	Church Rise Public Open Space, Undy, Caldicot, Monmouthshire, NP26 3NR	Public Open	91 sqm	Too small	n/a	n/a	n/a	Unsuitable
Church Road Public Open Space	Church Road Public Open Space, Church Road, Caldicot, Monmouthshire	Public Open	0.7 acres	0.7 acres	n/a	n/a	n/a	Next stage
Churchmead Open Space	Churchmead Open Space, Rogiet, Caldicot, Monmouthshire, NP26 3TG	Public Open	98 sqm	Too small	n/a	n/a	n/a	Unsuitable
Cinderhill Street Amenity Land	Cinderhill Street Amenity Land, Monmouth, Monmouthshire, NP25 5EY	Public Open	unknown	n/a	n/a	n/a	n/a	Unsuitable
Clearview Court (103.2 sq m) Public Open Space	Clearview Court (103.2 sq m) Public Open Space, Shirenewton, Chepstow, Monmouthshire	Public Open	0.02	Highways and too small	n/a	n/a	n/a	Unsuitable
Clearview Court (129.2 sq m) Public Open Space	Clearview Court (129.2 sq m) Public Open Space, Shirenewton, Chepstow, Monmouthshire	Public Open	0.03	Too small	n/a	n/a	n/a	Unsuitable
Clearview Court (14.09 sq m) Public Open Space	Clearview Court (14.09 sq m) Public Open Space, Shirenewton, Chepstow, Monmouthshire	Public Open	0.003	Too small	n/a	n/a	n/a	Unsuitable
Clearview Court (275.3 sq m) Public Open Space	Clearview Court (275.3 sq m) Public Open Space, Shirenewton, Chepstow, Monmouthshire	Public Open	0.06	Too small	n/a	n/a	n/a	Unsuitable
Clearview Court (321.9 sq m) Public Open Space	Clearview Court (321.9 sq m) Public Open Space, Shirenewton, Chepstow, Monmouthshire	Public Open	0.07	Too small	n/a	n/a	n/a	Unsuitable
Clearview Court (36.49 sq m) Public Open Space	Clearview Court (36.49 sq m) Public Open Space, Shirenewton, Chepstow, Monmouthshire	Public Open	0.008	Too small	n/a	n/a	n/a	Unsuitable
Clearview Court (39.31 sq m) Public Open Space	Clearview Court (39.31 sq m) Public Open Space, Shirenewton, Chepstow, Monmouthshire	Public Open	0.009	Too small	n/a	n/a	n/a	Unsuitable
Clearview Court (42.03 sq m) Public Open Space	Clearview Court (42.03 sq m) Public Open Space, Shirenewton, Chepstow, Monmouthshire	Public Open	0.009	Too small	n/a	n/a	n/a	Unsuitable
Clearview Court (204.7 sq m) Public Open Space	Clearview Court (204.7 sq m) Public Open Space, Shirenewton, Chepstow, Monmouthshire, NP16 6AX	Public Open	0.05	Too small	n/a	n/a	n/a	Unsuitable
Clos Alwen Public Open Space & Play Area	Clos Alwen Public Open Space & Playground, Clos Alwen, Caldicot, Monmouthshire	Public Open	1000 sqm	1000sqm	n/a	n/a	Childrens Play Area	Unsuitable
Clos Croeso Amenity Land	Clos Croeso Amenity Land, Usk, Monmouthshire, NP15 1AZ	Public Open	167 sqm	Too small	n/a	n/a	n/a	Unsuitable
Clos Rheidol Public Open Space	Clos Rheidol Public Open Space, Caldicot, Monmouthshire, NP26 4JD	Public Open	233 sqm	Too small	n/a	n/a	n/a	Unsuitable
Clos Rheidol Public Open Space (4 parcels)	Clos Rheidol Open Space (4 parcels), Clos Rheidol, Caldicot, Monmouthshire	Public Open	450 sqm	Too small	n/a	n/a	n/a	Unsuitable
Clydach Villa, Land adjacent to	Clydach Villa, Land adjacent to, Church Road, Clydach, Abergavenny, Monmouthshire, NP7 0LF	Public Open	1367 sqm	1367 sqm	n/a	Unclear - appears to be woodland	n/a	Unsuitable
Cobb Crescent Public Open Space	Cobb Crescent Public Open Space, Caldicot, Monmouthshire, NP26 5BY	Public Open	551 sqm	551 sqm	n/a	n/a	n/a	Next stage
Conigar Crescent Open Space	Conigar Crescent Open Space, Usk, Monmouthshire, NP15	Public Open	1400 sqm	1400 sqm	yes	n/a	n/a	Unsuitable
Cornford Close Public Open Space	Cornford Close Public Open Space, Osbaston, Monmouth, Monmouthshire, NP25 3NT	Public Open	560 sqm	560 sqm	unknown	Sloped? - no clear access	n/a	Unsuitable
Cornpoppy Avenue (269.9 sq m) Open Space	Cornpoppy Avenue (269.9 sq m) Open Space, Monmouth, Monmouthshire, NP25 5SD	Public Open	269sqm	Too small	n/a	n/a	n/a	Unsuitable
Cornwallis Way Public Open Space	Cornwallis Way Public Open Space, Monmouth, Monmouthshire, NP25 5DN	Public Open	369 sqm	369 sqm	n/a	n/a	n/a	Unsuitable
Courtfield Close (117.9 sq m) Open Space	Courtfield Close (117.9 sq m) Open Space, Monmouth, Monmouthshire, NP25 5ED	Public Open	117sqm	Too small	n/a	n/a	n/a	Unsuitable
Courthouse Road Public Open Space	Courthouse Road Public Open Space, Llanvair Discoed, Chepstow, Monmouthshire	Public Open	3400 sqm	3000 sqm but irregular shape - the	n/a	n/a	n/a	Unsuitable
Cowleaze Open space	Cowleaze Open space, Magor, Monmouthshire, NP26 3LE	Public Open	450 sqm	Too small	n/a	n/a	n/a	Unsuitable
Cresta Road (153.8 sq m) Open Space	Cresta Road (153.8 sq m) Open Space, Abergavenny, Monmouthshire, NP7 7AU	Public Open	0.03	Too small	n.a	n/a	n/a	Unsuitable
Cresta Road (321.5 sq m) Open Space	Cresta Road (321.5 sq m) Open Space, Abergavenny, Monmouthshire, NP7 7AU	Public Open	0.07	Too small	n.a	n/a	n/a	Unsuitable
Croesonen Gardens Open Space (104sqm)	Croesonen Gardens Open Space (104sqm), Abergavenny, Monmouthshire, NP7 6BJ	Public Open	0.02	Too small	n.a	n/a	n/a	Unsuitable
Croesonen Gardens Open Space (571sqm)	Croesonen Gardens Open Space (571sqm), Abergavenny, Monmouthshire, NP7 6BJ	Public Open	571 sqm	571 sqm - irregular shape so too small	n/a	n/a	n/a	Unsuitable
Croesonen Parc Public Open Space	Croesonen Parc Public Open Space, Abergavenny, Monmouthshire, NP7 6PF	Public Open	1.95 acres	1.95 acres	unknown	n/a	n/a	Next stage
Croesonnen Cottages, Land adjacent to	Croesonnen Cottages, Land adjacent to, Abergavenny, Monmouthshire, NP7 6BJ	Public Open	72 sqm	Too small	n/a	n/a	n/a	Unsuitable
Cybi Avenue Open Space	Cybi Avenue Open Space, Llangybi, Usk, Monmouthshire, NP15 1TU	Public Open Space	Too small	Too small	n/a	n/a	n/a	Unsuitable
Cybi Drive Open Space	Cybi Drive Open Space, Llangybi, Usk, Monmouthshire, NP15 1TU	Public Open	796 sqm	796 sqm	unknown	Flat	n/a	Next stage
Cybi Rise Open Space	Cybi Rise Open Space, Llangybi, Usk, Monmouthshire, NP15 1TU	Public Open	672 sqm	672 sqm	unknown	Flat	n/a	Next stage
De Cantelupe Close Open Space	De Cantelupe Close Open Space, Abergavenny, Monmouthshire, NP7 9JB	Public Open	12350 sqm	12350 sqm	unknown	Largely sloped topography	n/a	Unsuitable
Deans Hill Open Space	Deans Hill Open Space, Chepstow, Monmouthshire, NP16 5AT	Public Open	1209 sqm	1209 sqm	n/a	Unclear - appears to be sloped	n/a	Unsuitable
Deepweir Open Space (189.3 sq m)	Deepweir Open Space (189.3 sq m), Caldicot, Monmouthshire, NP26 5JG	Public Open	189sqm	Too small	n/a	n/a	n/a	Unsuitable
Deepweir Open Space (27.07) sq m	Deepweir Open Space (27.07) sq m, Caldicot, Monmouthshire, NP26 5JG	Public Open	27sqm	Too small	n/a	n/a	n.a	Unsuitable
Deepweir Open Space 137.5 sq m	Deepweir Open Space 137.5 sq m, Caldicot, Monmouthshire, NP26 5JG	Public Open	137sqm	Too small	n/a	n/a	n/a	Unsuitable
Deepweir Open Space 184.1sq m	Deepweir Open Space 184.1sq m, Caldicot, Monmouthshire, NP26 5JG	Public Open	184sqm	Too small	n/a	n/a	n/a	Unsuitable
Deepweir Open Space 75.32 sq m	Deepweir Open Space 75.32 sq m, Caldicot, Monmouthshire, NP26 5JG	Public Open	75sqm	Too small	n/a	n/a	n/a	Unsuitable
Delafield Road (2007 sq m) Open Space	Delafield Road (2007 sq m) Open Space, Abergavenny, Monmouthshire, NP7 7AW	Public Open	0.49	2007 sqm	unknown	Unfavourable topography	n/a	Unsuitable
Delafield Road (2803 sq m) Open Space	Delafield Road (2803 sq m) Open Space, Abergavenny, Monmouthshire, NP7 7AW	Public Open	0.69	2803 sqm	unknown	Sloped, unfavourable topography in	n/a	Unsuitable
Delafield Road (47.01sq m) Open Space	Delafield Road (47.01sq m) Open Space, Abergavenny, Monmouthshire, NP7 7AW	Public Open	0.01	Too small	n/a	n/a	n/a	Unsuitable
Deri View Open Space	Deri View Open Space, Charles Close, Abergavenny, Monmouthshire, NP7 6AX	Public Open	4936 sqm	4936 sqm	n/a	Car Park	n/a	Unsuitable
Derwen Way Open Space	Derwen Way Open Space, Abergavenny, Monmouthshire, NP7 6BP	Public Open Space	Too small	Too small	n/a	n/a	n/a	Unsuitable
Drybridge Park Open Space	Drybridge Park Open Space, Monmouth, Monmouthshire, NP25 5AS	Public Open	6.42 acres	6.42 acres	n/a	n/a	Skate Park	Unsuitable
Dunlin Avenue Public Open Space	Dunlin Avenue Public Open Space, Caldicot, Monmouthshire, NP26 5DL	Public Open	402 sqm	Too small	n/a	n/a	n/a	Unsuitable
Elan Way (26.65 sq m) Open Space	Elan Way (26.65 sq m) Open Space, Caldicot, Monmouthshire, NP26 4PZ	Public Open	26sqm	Too small	n/a	n/a	n/a	Unsuitable
Elan Way (303.4 sq m) Open Space	Elan Way (303.4 sq m) Open Space, Caldicot, Monmouthshire, NP26 4PZ	Public Open	303sqm	Too small	n/a	n/a	n/a	Unsuitable
Elan Way (334.3 sq m) Open Space	Elan Way (334.3 sq m) Open Space, Caldicot, Monmouthshire, NP26 4PZ	Public Open	334sqm	Too small	n/a	n/a	n/a	Unsuitable
Elan Way (45.9 sq m) Open Space	Elan Way (45.9 sq m) Open Space, Caldicot, Monmouthshire, NP26 4PZ	Public Open	45sqm	Too small	n/a	n/a	n/a	Unsuitable
Elan Way (6.386 sq m) Open Space	Elan Way (6.386 sq m) Open Space, Caldicot, Monmouthshire, NP26 4PZ	Public Open	6.3 sqm	Too small	n/a	n/a	n/a	Unsuitable
Elan Way (81.81 sq m) Open Space	Elan Way (81.81 sq m) Open Space, Caldicot, Monmouthshire, NP26 4PZ	Public Open	81sqm	Too small	n/a	n/a	n/a	Unsuitable
Elstob Way (196.5 sq m) Open Space	Elstob Way (196.5 sq m) Open Space, Monmouth, Monmouthshire, NP25 5ET	Public Open	196sqm	Too small	n/a	n/a	n/a	Unsuitable
Elstob Way (228.3 sq m) Open Space	Elstob Way (228.3 sq m) Open Space, Monmouth, Monmouthshire, NP25 5ET	Public Open	228sqm	Too small	n/a	n/a	n/a	Unsuitable
Elstob Way (285.6 sq m) Open Space	Elstob Way (285.6 sq m) Open Space, Monmouth, Monmouthshire, NP25 5ET	Public Open	285sqm	Too small	n/a	n/a	n/a	Unsuitable
Elstob Way (370.2 sq m) Open Space	Elstob Way (370.2 sq m) Open Space, Monmouth, Monmouthshire, NP25 5ET	Public Open	370sqm	Too small	n/a	n/a	n/a	Unsuitable
Elstob Way (375.4 sq m) Open Space	Elstob Way (375.4 sq m) Open Space, Monmouth, Monmouthshire, NP25 5ET	Public Open	375sqm	Too small	n/a	n/a	n/a	Unsuitable
Elstob Way (58.13 sq m) Open Space	Elstob Way (58.13 sq m) Open Space, Monmouth, Monmouthshire, NP25 5ET	Public Open	58sqm	Too small	n/a	n/a	n/a	Unsuitable
Elstob Way (strip) Open Space	Elstob Way (strip) Open Space, Monmouth, Monmouthshire, NP25 5ET	Public Open Space	Too small	Too small	n/a	n/a	n/a	Unsuitable
Ethley Drive (5608 sq m) Open Space	Ethley Drive (5608 sq m) Open Space, Raglan, Usk, Monmouthshire, NP26 2FB	Public Open	5608 sqm	5608 sqm	Yes	n/a	n/a	Unsuitable
Fedw Wood Open Space (3977sqm)	Fedw Wood Open Space (3977sqm), Bayfield, Chepstow, Monmouthshire, NP16 5TW	Public Open	0.98	0.98 acres	unknown	Area of woodland	n/a	Unsuitable
Ferney Cross Public Open Space	Ferney Cross Public Open Space, Longfellow Road, Caldicot, Monmouthshire, NP26 4QY	Public Open	0.79 acres	3200 sqm	unknown	Flat	n/a	Next stage
Fitzroy Close Open Space (Clawddu)	Fitzroy Close Open Space (Clawddu), Monmouth, Monmouthshire, NP25 5BJ	Public Open	1605 sqm	Irregular shape - Too small	n/a	n/a	n/a	Unsuitable
Forest Hill Open Space	Forest Hill Open Space, Gilwern, Abergavenny, Monmouthshire, NP7 0DY	Public Open	560 sqm	560 sqm	n/a	Unfavourable topography	n/a	Unsuitable
Forest View Amenity Land	Forest View Amenity Land, The Narth, Monmouth, Monmouthshire, NP25 4QQ	Public Open	270 sqm	Too small	n/a	n/a	n.a	Unsuitable
Former Railway Usk, Land comprising	Former Railway Usk, Land comprising 7 parcels, Usk, Monmouthshire, NP15	Public Open	1.82 acres	1.82 acres	unknown	Unfavourable topography	n/a	Unsuitable
Fountain Way (1478 sq m) Public Open Space	Fountain Way (1478 sq m) Public Open Space, Chepstow, Monmouthshire, NP16 5SZ	Public Open	0.365	1478 sqm	unknown	n/a	n/a	Next stage
Garthi Close Open Space	Garthi Close Open Space, Mitchel Troy, Monmouth, Monmouthshire, NP25 4JN	Public Open	6318 qm	6318 sqm	n/a	n/a	n/a	Next stage
Garvey Close (158.5 sq m) Public Open Space	Garvey Close (158.5 sq m) Public Open Space, Chepstow, Monmouthshire, NP16 5TD	Public Open	158sqm	Too small	n/a	n/a	n/a	Unsuitable
Garvey Close (296.5 sq m) Public Open Space	Garvey Close (296.5 sq m) Public Open Space, Chepstow, Monmouthshire, NP16 5TD	Public Open	296sqm	Too small	n/a	n/a	n/a	Unsuitable
Geoffrey Drive Open Space	Geoffrey Drive Open Space, Monmouth, Monmouthshire, NP25 5TR	Public Open	6027 sqm	6027 sqm	n/a	n/a	Childrens Play Area	Unsuitable
Gethin Place Amenity Land	Gethin Place Amenity Land, Llanfair Kilgeddin, Abergavenny, Monmouthshire, NP7 9EA	Public Open	423 sqm	Too small	n.a	n/a	n/a	Unsuitable

Vegetation

Resi area, access constrained

Glan Gavenny Open Space	Glan Gavenny Open Space, Abergavenny, Monmouthshire, NP7 6NQ	Public Open	4024 sqm	Irregular shape - Too small	Yes	n/a	n/a	Unsuitable
Goldwire Lane Amenity Land	Goldwire Lane Amenity Land, Monmouth, Monmouthshire, NP25 5AL	Public Open	277 sqm	Too small	n/a	n/a	n/a	Unsuitable
Goldwire Lane Open Space	Goldwire Lane Open Space, Monmouth, Monmouthshire, NP25 5AQ	Public Open	1509 sqm	1509 sqm	n/a	n/a	n/a	Next stage
Granville Street, Land at	Granville Street, Land at, Monmouth, Monmouthshire, NP25 3DR	Public Open	630 sqm	630 sqm	n/a	n/a	n/a	Next stage
Green Moor Lane Public Open Space	Green Moor Lane Public Open Space, Magor, Caldicot, Monmouthshire, NP26 3NB	Public Open	70 sqm	Too small	n/a	n/a	n/a	Unsuitable
Greenlands Close Public Open Space	Greenlands Close Public Open Space, Wyesham, Monmouth, Monmouthshire, NP25 3LP	Public Open	1064 sqm	1064 sqm	unknown	Woodland	n/a	Unsuitable
Greenmeadow Crescent Public Open Space	Greenmeadow Crescent Public Open Space, Little Mill, Usk, Monmouthshire	Public Open	1048 sqm	1048 sqm	n/a	n/a	Childrens Play Area	Unsuitable
Grosmont Close (4691 sq m) Open Space	Grosmont Close (4691 sq m) Open Space, Monmouth, Monmouthshire, NP25 5UF	Public Open	4691 sqm	4691 sqm	n/a	n/a	n/a	Next stage
Hadnock Road & River Wye, Land between	Hadnock Road & River Wye, Land between, Monmouth, Monmouthshire, NP25	Public Open	5400 sqm	Irregular shape - Too small	n/a	n/a	n/a	Unsuitable
Hamilton Way Open Space (1244sqm)	Hamilton Way Open Space (1244sqm), Monmouth, Monmouthshire, NP25 5BY	Public Open	1244 sqm	1244 sqm	n/a	Woodland	n/a	Unsuitable
Hastings Close Open Space	Hastings Close Open Space, Abergavenny, Monmouthshire, NP7 9JD	Public Open	1.28 acres	1.28 acres	n/a	n/a	Playing Fields	Unsuitable
Hawthorn Close (264.3 sq m) Open Space	Hawthorn Close (264.3 sq m) Open Space, Chepstow, Monmouthshire, NP16 5RG	Public Open	264sqm	Too small	n/a	n/a	n/a	Unsuitable
Heol Sirhowy Open Space	Heol Sirhowy Open Space, Heol Sirhowy, Caldicot	Public Open	4900 sqm	4900 sqm	n/a	n/a	Childrens Play Area / Playing	Unsuitable
Heol Teifi Public Open Space & Playground	Heol Teifi Open Space & Playground (2 parcels) 15540sqm, Caldicot, Monmouthshire	Public Open	3.8	3.8 acres	n/a	n/a	Childrens Play Area	Unsuitable
Heol Teifi Public Open Space & Playground	Heol Teifi Public Open Space & Playground (2 parcels) 882.3 sqm, Heol Teifi, Caldicot, Monmouthshire	Public Open	0.21	0.21 acres	n/a	n/a	Childrens Play Area	Unsuitable
Heol Towy Public Open Space & Playground	Heol Towy Public Open Space & Playground, Heol Towy, Caldicot, Monmouthshire	Public Open	n/a	n/a	n/a	n/a	Childrens Play Area	Unsuitable
High Beech Lane Open Space	High Beech Lane Open Space, Chepstow, Monmouthshire, NP16 5BQ	Public Open	1095 sqm	1095 sqm	n/a	n/a	n/a	Next stage
Highfield Amenity Land	Highfield Amenity Land, Goytre, Abergavenny, Monmouthshire, NP4 0AQ	Public Open	426 sqm	Too small	n/a	n/a	n/a	Unsuitable
Highfield Communal Area	Highfield Communal Area, Goetre, Abergavenny, Monmouthshire, NP4 0BH	Public Open	467 sqm	Too small	n/a	n/a	n/a	Unsuitable
Highmeadow Open Space	Highmeadow Open Space, Wyesham, Monmouth, Monmouthshire, NP25 3TB	Public Open	107 sqm	Too small	n/a	n/a	n/a	Unsuitable
Hill Barn View Open Space	Hill Barn View Open Space, Portskewett, Caldicot, Monmouthshire, NP26 5SE	Public Open	0.32 acres	0.32 acres	n/a	n/a	n/a	Next stage
Holly Close (126.5 sq m) Open Space	Holly Close (126.5 sq m) Open Space, Chepstow, Monmouthshire, NP16 5RP	Public Open	126sqm	Too small	n/a	n/a	n/a	Unsuitable
Holly Close (28.16 sq m) Open Space	Holly Close (28.16 sq m) Open Space, Chepstow, Monmouthshire, NP16 5RP	Public Open	28sqm	Too small	n/a	n/a	n/a	Unsuitable
Holly Close (34.86 sq m) Open Space	Holly Close (34.86 sq m) Open Space, Chepstow, Monmouthshire, NP16 5RP	Public Open	34sqm	Too small	n/a	n/a	n/a	Unsuitable
Holly Close (445.8 sq m) Open Space	Holly Close (445.8 sq m) Open Space, Chepstow, Monmouthshire, NP16 5RP	Public Open	445sqm	Too small	n/a	n/a	n/a	Unsuitable
Holywell Close (376.2 sq m) Open Space	Holywell Close (376.2 sq m) Open Space, Monmouth, Monmouthshire, NP25 5EU	Public Open	376sqm	Too small	n/a	n/a	n/a	Unsuitable
Holywell Close (423.5 sq m) Open Space	Holywell Close (423.5 sq m) Open Space, Monmouth, Monmouthshire, NP25 5EU	Public Open	423sqm	Too small	n/a	n/a	n/a	Unsuitable
Holywell Crescent Open Space	Holywell Crescent Open Space, Abergavenny, Monmouthshire, NP7 5LG	Public Open	919 sqm	919 sqm	n/a	n/a	n/a	Next stage
Jordans Way Public Open Space	Jordans Way Public Open Space, Monmouth, Monmouthshire, NP25 5EA	Public Open	397 sqm	397 sqm	n/a	n/a	n/a	Unsuitable
Kemeys Road Amenity Land & Sewerage	Kemeys Road Amenity Land & Sewerage Works, Llancayo, Usk, Monmouthshire, NP15 1JA	Public Open	3462 sqm	3462 sqm	yes	n/a	n/a	Unsuitable
Kemys Craig Wood, Land at	Kemys Craig Wood, Land at, Llantrisant, Usk, Monmouthshire	Public Open Space	unknown	unknown	n/a	Woodland	n/a	Unsuitable
Kensington Park (415 sq m) Public Open Space	Kensington Park (415 sq m) Public Open Space, Magor, Caldicot, Monmouthshire, NP26 3QH	Public Open	0.1	Too small	n/a	n/a	n/a	Unsuitable
Kensington Park (729 sq m) Public Open Space	Kensington Park (729 sq m) Public Open Space, Magor, Caldicot, Monmouthshire, NP26 3QH	Public Open	0.18	729 sqm	n/a	n/a	n/a	Next stage
Kings Fee Open Space	Kings Fee Open Space, Monmouth, Monmouthshire, NP25 5BW	Public Open Space	3652 sqm	3652 sqm	n/a	n/a	Childrens Play Area	Unsuitable
Kingsmark Lane (222 sq m) Public Open Space	Kingsmark Lane (222 sq m) Public Open Space, Chepstow, Monmouthshire, NP16 5LZ	Public Open	0.05	Too Small	n.a	n/a	n/a	Unsuitable
Kingsmark Lane (242 sq m) Public Open Space	Kingsmark Lane (242 sq m) Public Open Space, Chepstow, Monmouthshire, NP16 5LZ	Public Open	0.06	Too Small	n/a	n/a	n/a	Unsuitable
Laburnam Way (113.1 sq m) Open Space	Laburnam Way (113.1 sq m) Open Space, Chepstow, Monmouthshire, NP16 5RF	Public Open	113sqm	Too small	n/a	n/a	n/a	Unsuitable
Laburnam Way (521.6 sq m) Open Space	Laburnam Way (521.6 sq m) Open Space, Chepstow, Monmouthshire, NP16 5RF	Public Open	521sqm	Irregular shape - Too small	n/a	n/a	n/a	Unsuitable
Lancaster Way Public Open Space	Lancaster Way Public Open Space, Osbaston, Monmouth, Monmouthshire, NP25 3BE	Public Open	4943 sqm	4943 sqm	unknown	Sloping - potential for smaller plot	n/a	Next stage
Landau Close (136.8) Open Space	Landau Close (136.8) Open Space, Undy, Magor, Monmouthshire, NP26 3NT	Public Open	136sqm	Too small	n/a	n/a	n/a	Unsuitable
Landau Close (351.7) Open Space	Landau Close (351.7) Open Space, Undy, Magor, Monmouthshire, NP26 3NT	Public Open	351sqm	Too small	n/a	n/a	n/a	Unsuitable
Lapwing Avenue Open Space	Lapwing Avenue Open Space, Undy, Magor, Monmouthshire, NP26 5RN	Public Open	614 sqm	614 sqm	Irregular shape - too small	n/a	n/a	Unsuitable
Laurel Close Open Space	Laurel Close Open Space, Undy, Magor, Monmouthshire, NP26 3NP	Public Open	100 sqm	Too small	n/a	n/a	n/a	Unsuitable
Laurel Close Open Space	Laurel Close Open Space, Undy, Magor, Monmouthshire, NP26 3NP	Public Open	112 sqm	Too small	n/a	n/a	n/a	Unsuitable
Levitsfield Close Open Space (1255sqm)	Levitsfield Close Open Space (1255sqm), Monmouth, Monmouthshire, NP25 5BZ	Public Open Space	unknown	Irregular shape - Too small	n/a	n/a	n/a	Unsuitable
Levitsfield Close Public Open Space	Levitsfield Close Public Open Space, Monmouth, Monmouthshire, NP25 5BZ	Public Open Space	unknown	Too small	n/a	n/a	n/a	Unsuitable
Limetree Avenue Amenity Land	Limetree Avenue Amenity Land, Wyesham, Monmouth, Monmouthshire, NP25 3LA	Public Open	356 sqm	Too small	n/a	n/a	n/a	Unsuitable
Linnet Road Public Open Space	Linnet Road Public Open Space, Caldicot, Monmouthshire, NP26 5DJ	Public Open	424 sqm	Too small	n/a	n/a	n/a	Unsuitable
Llanellen Road Amenity Land	Llanellen Road Amenity Land, Llanfoist, Abergavenny, Monmouthshire, NP7 9LY	Public Open	1711 sqm	1711 sqm	n/a	n/a	n/a	Next stage
Llanvair Road Open Space	Llanvair Road Open Space, Caerwent, Caldicot, Monmouthshire, NP26 5NY	Public Open	1356 sqm	1356 sqm	n/a	n/a	n/a	Next stage
LLwyn Melin Open Space	LLwyn Melin Open Space, Clydach, Abergavenny, Monmouthshire, NP7 0LJ	Public Open	Too small	Too small	n/a	n/a	n/a	Unsuitable
Longfellow Close Public Open Space	Longfellow Close Public Open Space, Caldicot, Monmouthshire, NP26 4LD	Public Open	239 sqm	Too small	n/a	n/a	n/a	Unsuitable
Maesy Llwydd ( 1086sqm) Open Space	Maesy Llwydd ( 1086sqm) Open Space, Abergavenny, Monmouthshire, NP7 5LQ	Public Open Space	1086 sqm	1086 sqm	n.a	Unfavourable topography	n/a	Unsuitable
Maesy Llwydd ( 653.4sqm) Open Space	Maesy Llwydd ( 653.4sqm) Open Space, Abergavenny, Monmouthshire, NP7 5LQ	Public Open	653 sqm	653 sqm	n/a	n/a	Childrens Play Area	Unsuitable
Main Road (264.9 sq m) Open Space	Main Road (264.9 sq m) Open Space, Magor, Caldicot, Monmouthshire, NP26 3HN	Public Open	264sqm	Too small	n/a	n/a	n/a	Unsuitable
Manor Wood Open Space (259.6 sqm)	Manor Wood Open Space (259.6 sqm), Bayfield, Chepstow, Monmouthshire, NP16 6DS	Public Open	259sqm	Too small	n/a	n/a	n/a	Unsuitable
Manson Heights Amenity Land	Manson Heights Amenity Land, Monmouth, Monmouthshire, NP25 5QX	Public Open	775	775 sqm	n/a	n/a	n/a	Next stage
Maple Avenue (109.3 sq m) Open Space	Maple Avenue (109.3 sq m) Open Space, Chepstow, Monmouthshire, NP16 5RG	Public Open	109sqm	too small	n/a	n/a	n/a	Unsuitable
Maple Avenue (120.1 sq m) Open Space	Maple Avenue (120.1 sq m) Open Space, Chepstow, Monmouthshire, NP16 5RG	Public Open	120sqm	too small	n/a	n/a	n/a	Unsuitable
Maple Avenue (171.6 sq m) Open Space	Maple Avenue (171.6 sq m) Open Space, Chepstow, Monmouthshire, NP16 5RG	Public Open	171 sqm	too small	n/a	n/a	n/a	Unsuitable
Maple Avenue (56.64 sq m) Open Space	Maple Avenue (56.64 sq m) Open Space, Chepstow, Monmouthshire, NP16 5RG	Public Open	56sqm	too small	n/a	n/a	n/a	Unsuitable
Maple Avenue (674.1 sq m) Open Space	Maple Avenue (674.1 sq m) Open Space, Chepstow, Monmouthshire, NP16 5RG	Public Open	674 sqm	674 sqm	n/a	n/a	Playing Fields	Unsuitable
Martin Close Open Space	Martin Close Open Space, Rogiet, Caldicot, Monmouthshire, NP26 3UG	Public Open	715 sqm	715 sqm	n/a	n/a	Childrens Play Area	Unsuitable
Mary De Bohun Close (708.6 sq m) Open Space	Mary De Bohun Close (708.6 sq m) Open Space, Monmouth, Monmouthshire, NP25 5UB	Public Open	708 sqm	708 sqm	n/a	n/a	n/a	Next stage
Mayfield Lodge, Land adjacent	Mayfield Lodge, Land adjacent, Usk, Monmouthshire, NP15	Public Open	1.95 acres	1.95 acres	Yes	n/a	n/a	Unsuitable
Meadow Rise (115.1 sq m) Open Space	Meadow Rise (115.1 sq m) Open Space, Undy, Magor, Monmouthshire, NP26 3JW	Public Open	115sqm	Too small	N/a	N/a	N/a	Unsuitable
Meadow Rise (132.1 sq m) Open Space	Meadow Rise (132.1 sq m) Open Space, Undy, Magor, Monmouthshire, NP26 3JW	Public Open	132sqm	Too small	N/a	N/a	N/a	Unsuitable
Merlin Close Open Space	Merlin Close Open Space, Monmouth, Monmouthshire, NP26 3UX	Public Open	368 sqm	Irregular shape - Too small	n/a	n/a	n/a	Unsuitable
Mill Common Open Space	Mill Common Open Space, Magor, Caldicot, Monmouthshire, NP26 3JH	Public Open	7.6 acres	7.6 acres	n/a	Planting/Woodland	n/a	Unsuitable
Mill Reen ( 564 sq m) Open Space	Mill Reen ( 564 sq m) Open Space, Magor, Caldicot, Monmouthshire, NP26 3JP	Public Open	564 sqm	564 sqm	Yes	n/a	n/a	Unsuitable
Mill Reen (425.6 sq m) Open Space	Mill Reen (425.6 sq m) Open Space, Magor, Caldicot, Monmouthshire, NP26 3JP	Public Open	425sqm	Too small	N/a	N/a	N/a	Unsuitable
Millfield Park Open Space	Millfield Park Open Space, Magor, Caldicot, Monmouthshire, NP26 3LF	Public Open Space	unknown	Too small	n/a	n/a	n/a	Unsuitable
Mount Pleasant Open Space	Mount Pleasant Open Space, Main Road, Clydach, Abergavenny, Monmouthshire, NP7 0LL	Public Open	287 sqm	Too small	n/a	n/a	n/a	Unsuitable
Mounton Close Open Space	Mounton Close Open Space, Chepstow, Monmouthshire, NP16 5EG	Public Open	881 sqm	881 sqm	n/a	n/a	n/a	Next stage
Mounton Drive Open Space	Mounton Drive Open Space, Chepstow, Monmouthshire, NP16 5EH	Public Open	1961 sqm	1961 sqm	n/a	n/a	Playing Fields	Unsuitable
Neddern Court Open Space(East)	Neddern Court Open Space(East), Neddern Way, Caldicot, Monmouthshire, NP26 4GX	Public Open	2013 sqm	2013 sqm	n/a	n/a	Playing Fields / Playground	Unsuitable
Neddern Court Open Space(West)	Neddern Court Open Space(West), Neddern Way, Caldicot, Monmouthshire, NP26 4GX	Public Open	4611 sqm	4611 sqm	n/a	n/a	Playing Fields / Playground	Unsuitable
Newport Road Public Open Space	Newport Road Public Open Space, Adj Westfield, Caldicot, Monmouthshire, NP26 4AE	Public Open	35 sqm	Too small	n/a	n/a	n/a	Unsuitable
Nightingale Close Public Open Space	Nightingale Close Public Open Space, Caldicot, Monmouthshire, NP26 5ES	Public Open	415 sqm	Too small	n/a	n/a	n/a	Unsuitable
Normandy Way Public Open Space	Normandy Way Public Open Space, Chepstow, Monmouthshire, NP16 5NB	Public Open	2 acres	2 acres	unknown	Sloped	n.a	Unsuitable
North East of Pwll Bach ( off A449), Land	North East of Pwll Bach ( off A449), Land, Llantrisant, Usk, Monmouthshire	Public Open Space	unknown	Too small	n/a	Woodland	n/a	Unsuitable

Access constrained

Access

Access

D  
O  
S  
E

Access

North of Newbridge on Usk Picnic site	North of Newbridge on Usk Picnic site (off A449), Land, Llantrisant, Usk, Monmouthshire	Public Open Space	Too small	n/a	Woodland	n/a	Unsuitable
Oak Close Open Space	Oak Close Open Space, Undy, Magor, Monmouthshire, NP26 3LR	Public Open Space	Too small	n/a	n/a	n/a	Unsuitable
Oak Grove Open Space	Oak Grove Open Space, Rockfield, Monmouth, Monmouthshire, NP25 5PY	Public Open	3003 sqm	3003 sqm	n/a	Topography unclear	Next stage
Oaklands Drive (11030 sq m) Open Space	Oaklands Drive (11030 sq m) Open Space, Monmouth, Monmouthshire, NP25 5DT	Public Open Space	2.38 acres	2.38 acres	Yes	n/a	Unsuitable
Oaklands Drive (274.1sqm) Public Open Space	Oaklands Drive (274.1sqm) Public Open Space, Monmouth, Monmouthshire, NP25 5DT	Public Open	274sqm	Too small	N/a	N/a	Unsuitable
Oakley Way, Land at rear	Oakley Way, Land at rear, Caldicot, Monmouthshire, NP26 4EA	Public Open	813 sqm	Irregular shape - Too small	n/a	n/a	Unsuitable
Orchard Close Amenity Land	Orchard Close Amenity Land, Skenfrith, Abergavenny, Monmouthshire, NP7 8UG	Public Open	256 sqm	Too small	n/a	n/a	Unsuitable
Orchid Drive Open Space	Orchid Drive Open Space, Undy, Magor, Monmouthshire, NP26 5GE	Public Open	3.4 acres	3.4 acres	unknown	n/a	childrens area on small area
Osprey Drive Open Space	Osprey Drive Open Space, Undy, Magor, Monmouthshire, NP26 5RL	Public Open	295 sqm	Too small	n/a	n/a	Unsuitable
Park Crescent & Hereford Road Open Space	Park Crescent & Hereford Road Open Space, Abergavenny, Lansdown, NP7 5TN	Public Open	476 sqm	Too small	n/a	n/a	Unsuitable
Park Crescent Open Space	Park Crescent Open Space, Abergavenny, Monmouthshire, NP7 5TN	Public Open	289 sqm	Too small	n/a	n/a	Unsuitable
Pembroke Court Open space	Pembroke Court Open space, Undy, Caldicot, Monmouthshire, NP26 3QD	Public Open	139 sqm	Too small	n/a	n/a	Unsuitable
Pennyfarthing Lane Open Space	Pennyfarthing Lane Open Space, Undy, Magor, Monmouthshire, NP26 3NU	Public Open	3.3 acres	3.3 acres	n/a	Vegetation/woodland	Unsuitable
Pentery Park (15940 sq m) Open Space	Pentery Park (15940 sq m) Open Space, Chepstow, Monmouthshire, NP16 5AZ	Public Open	15940 sqm	15940 sqm	n/a	Unfavourable topography	n.a
Pentery Park (383 sq m) Open Space	Pentery Park (383 sq m) Open Space, Chepstow, Monmouthshire, NP16 5AZ	Public Open	383sqm	Too small	N/a	N/a	Unsuitable
Phoenix Drive (329.3 sq m) Open Space	Phoenix Drive (329.3 sq m) Open Space, Chepstow, Monmouthshire, NP16 5TJ	Public Open	329sqm	Too small	N/a	N/a	Unsuitable
Plas Mynydd Open Space	Plas Mynydd Open Space, Llanfoist, Abergavenny, Monmouthshire, NP7 9FJ	Public Open	432 sqm	Too small	n/a	n/a	Unsuitable
Plover Crescent Open Space	Plover Crescent Open Space, Undy, Magor, Monmouthshire, NP26 5ET	Public Open	995 sqm	995 sqm	n/a	n/a	Next stage
Poorscript Lane Amenity Land	Poorscript Lane Amenity Land, Grosmont, Abergavenny, Monmouthshire, NP7 8LP	Public Open	528 sqm	528 sqm	n/a	Unclear	n/a
Poplar Close (376.7 sq m) Open Space	Poplar Close (376.7 sq m) Open Space, Rogiet, Caldicot, Monmouthshire, NP26 3TL	Public Open	376sqm	Too small	n/a	n/a	Unsuitable
Poplar Close (91.75 sq m) Open Space	Poplar Close (91.75 sq m) Open Space, Rogiet, Caldicot, Monmouthshire, NP26 3TL	Public Open	91sqm	Too small	n/a	n/a	Unsuitable
Port Mahon Close (111.4 sq m) Open Space	Port Mahon Close (111.4 sq m) Open Space, Monmouth, Monmouthshire, NP25 5DX	Public Open	111sqm	Too small	n/a	n/a	Unsuitable
Port Mahon Close (57.99 sq m) Open Space	Port Mahon Close (57.99 sq m) Open Space, Monmouth, Monmouthshire, NP25 5DX	Public Open	57sqm	Too small	n/a	n/a	Unsuitable
Port Mahon Close (88.51 sq m) Open Space	Port Mahon Close (88.51 sq m) Open Space, Monmouth, Monmouthshire, NP25 5DX	Public Open	88sqm	Too small	n/a	n/a	Unsuitable
Prince Charles Road (299.2 sq m) Open Space	Prince Charles Road (299.2 sq m) Open Space, Raglan, Usk, Monmouthshire, NP15 2FB	Public Open	299sqm	Too small	n/a	n/a	Unsuitable
Prince Charles Road Open Space	Prince Charles Road Open Space, Raglan, Monmouthshire, NP15 2FB	Public Open	3894 sqm	3894 sqm	n/a	n/a	Childrens Play Area
Priory Close Public Open Space	Priory Close Public Open Space, Chepstow, Monmouthshire, NP16 5ND	Public Open	81 sqm	Too small	n/a	n/a	Unsuitable
Quarry Rise Open Space	Quarry Rise Open Space, Undy, Magor, Monmouthshire, NP25 3JU	Public Open	1324 sqm	1324 sqm	n/a	Unfavourable topography	Unsuitable
Reade Street Open Space	Reade Street Open Space, Wyesham, Monmouth, Monmouthshire, NP25 3TJ	Public Open	1328 sqm	1328 sqm	n/a	Unfavourable topography	Unsuitable
Redbrook Road Amenity Land	Redbrook Road Amenity Land, Wyesham, Monmouth, Monmouthshire	Public Open	1351 sqm	1351 sqm	n/a	Unfavourable topography	Unsuitable
Rhyd y Meirch Open Space	Rhyd y Meirch Open Space, Llanover, Abergavenny, Monmouthshire, NP7 9EU	Public Open	1810 sqm	1810 sqm	n/a	n/a	Next stage
River View (289.7 sq m) Open Space	River View (289.7 sq m) Open Space, Chepstow, Monmouthshire, NP16 5AX	Public Open	289sqm	Too small	n/a	n/a	Unsuitable
River View (331.5 sq m) Open Space	River View (331.5 sq m) Open Space, Chepstow, Monmouthshire, NP16 5AX	Public Open	331sqm	Too small	n/a	n/a	Unsuitable
River View (560.9 sq m) Open Space	River View (560.9 sq m) Open Space, Chepstow, Monmouthshire, NP16 5AX	Public Open	560 sqm	Irregular shape - Too small	n/a	n/a	Unsuitable
Rockfield Grove (1022 sq m) Open Space	Rockfield Grove (1022 sq m) Open Space, Undy, Caldicot, Monmouthshire, NP26 3FB	Public Open	1022 sqm	1022 sqm	Attenuation?	n/a	Next stage
Rockfield Grove (483.6 sq m) Open Space	Rockfield Grove (483.6 sq m) Open Space, Undy, Caldicot, Monmouthshire, NP26 3FB	Public Open Space	Too small	Too small	n/a	n/a	Unsuitable
Rockfield View Open Space	Rockfield View Open Space, Undy, Magor, Monmouthshire, NP26 3FD	Public Open	1177sqm	1177 sqm	n/a	n/a	Childrens Play Area
Rockfield Way Open Space	Rockfield Way Open Space, Undy, Magor, Monmouthshire, NP26 3FD	Public Open	2139 sqm	Irregular shape - Too small	n.a	n/a	Unsuitable
Rocklea Open Space	Rocklea Open Space, Mitchell Troy, Monmouth, Monmouthshire, NP25 4JE	Public Open	0.74 acres	0.74 acres	unknown	n/a	Next stage
Rogiet Primary, Land adjacent (14384.4sqm) Open Space	Rogiet Primary, Land adjacent, Station Road, Rogiet, Monmouthshire, NP26 3SD	Public Open	14384 sqm	14384 sqm	n/a	School grounds	n/a
Rolls Avenue Open Space	Rolls Avenue Open Space, Monmouth, Monmouthshire, NP25 5AY	Public Open	354 sqm	too small	n/a	n/a	Unsuitable
Ross Road (9085 sq m) Open Space	Ross Road (9085 sq m) Open Space, Abergavenny, Monmouthshire, NP7 5LT	Public Open	2.24 acres	2.24 acres	Yes	Unfavourable topography	n.a
Rowan Drive (111.3 sq m) Open Space	Rowan Drive (111.3 sq m) Open Space, Chepstow, Monmouthshire, NP16 5RQ	Public Open	111sqm	Too small	n/a	n/a	Unsuitable
Rowan Drive (132.8 sq m) Open Space	Rowan Drive (132.8 sq m) Open Space, Chepstow, Monmouthshire, NP16 5RQ	Public Open	132sqm	Too small	n/a	n/a	Unsuitable
Rowan Drive (153.3 sq m) Open Space	Rowan Drive (153.3 sq m) Open Space, Chepstow, Monmouthshire, NP16 5RQ	Public Open	153sqm	Too small	n/a	n/a	Unsuitable
Rowan Drive (26.91 sq m) Open Space	Rowan Drive (26.91 sq m) Open Space, Chepstow, Monmouthshire, NP16 5RQ	Public Open	26sqm	Too small	n/a	n/a	Unsuitable
Rowan Drive (46.6 sq m) Open Space	Rowan Drive (46.6 sq m) Open Space, Chepstow, Monmouthshire, NP16 5RQ	Public Open	46sqm	Too small	n/a	n/a	Unsuitable
Rowan Drive (911.3 sq m) Open Space	Rowan Drive (911.3 sq m) Open Space, Chepstow, Monmouthshire, NP16 5RQ	Public Open	911 sqm	911 sqm	n/a	n/a	Next Stage
Rowing Club, Land adjacent	Rowing Club, Land adjacent, Monmouth, Monmouthshire, NP25 3DP	Public Open	4634 sqm	4634 sqm	Yes	n/a	n/a
Rushey Meadow Open Space (7518sqm)	Rushey Meadow Open Space (7518sqm), Monmouth, Monmouthshire, NP25 5BT	Public Open	7518 sqm	Irregular shape - Too small	n/a	n/a	Unsuitable
Rushey Meadow Public Open Space	Rushey Meadow Public Open Space, Monmouth, Monmouthshire, NP25 5BT	Public Open	?	Irregular shape - Too small	n/a	n/a	Unsuitable
Samuel Rodgers Crescent (155.8sqm)	Samuel Rodgers Crescent (155.8sqm) Open Space, Thornwell, Chepstow, Monmouthshire, NP16 5GB	Public Open	0.03	Too small	n/a	n/a	Unsuitable
Samuel Rodgers Crescent (162.8sqm)	Samuel Rodgers Crescent (162.8sqm) Open Space, Thornwell, Chepstow, Monmouthshire, NP16 5GB	Public Open	0.04	Too small	n/a	n/a	Unsuitable
Samuel Salter Close (342.3 sq m) Open Space	Samuel Salter Close (342.3 sq m) Open Space, Llanfoist, Abergavenny, Monmouthshire, NP7 9NZ	Public Open	342sqm	Too small	n/a	n/a	Unsuitable
Sarno Square (170705 sq m) Open Space	Sarno Square (170705 sq m) Open Space, Abergavenny, Monmouthshire, NP7 5JT	Public Open	42 acres	42 acres	n/a	n/a	Next stage
School Hill (153.6 sq m) Open Space	School Hill (153.6 sq m) Open Space, Chepstow, Monmouthshire, NP16 5BZ	Public Open	153sqm	Too small	n/a	n/a	Unsuitable
School Hill (30.10 sq m) Open Space	School Hill (30.10 sq m) Open Space, Chepstow, Monmouthshire, NP16 5BZ	Public Open	30sqm	Too small	n/a	n/a	Unsuitable
School Hill (368.3 sq m) Open Space	School Hill (368.3 sq m) Open Space, Chepstow, Monmouthshire, NP16 5BZ	Public Open	368sqm	Too small	n/a	n/a	Unsuitable
School Hill (399.5 sq m) Open Space	School Hill (399.5 sq m) Open Space, Chepstow, Monmouthshire, NP16 5BZ	Public Open	399 sqm	Too small	n/a	n/a	Unsuitable
School Hill (40.98 sq m) Open Space	School Hill (40.98 sq m) Open Space, Chepstow, Monmouthshire, NP16 5BZ	Public Open	40sqm	Too small	n/a	n/a	Unsuitable
School Hill (8.743 sq m) Open Space	School Hill (8.743 sq m) Open Space, Chepstow, Monmouthshire, NP16 5BZ	Public Open	8sqm	Too small	n/a	n/a	Unsuitable
Shakespeare Drive Open Space	Shakespeare Drive Open Space, Caldicot, Monmouthshire, NP26 4LW	Public Open	366 sqm	Too small	n/a	n/a	Unsuitable
Shelley Close Public Open Space	Shelley Close Public Open Space, Caldicot, Monmouthshire, NP26 4LQ	Public Open	1085 sqm	1085 sqm	unknown	unknown	unknown
Somerset Road Open Space	Somerset Road Open Space, Monmouth, Monmouthshire, NP25 5AJ	Public Open	206 sqm	Too small	n/a	n/a	Unsuitable
Somerset Way Open Space	Somerset Way Open Space, Chepstow, Monmouthshire, NP16 5NP	Public Open	300 sqm	Too small	n/a	n/a	Unsuitable
St Andrews Crescent Amenity Land (180.8 sqm)	St Andrews Crescent Amenity Land (180.8 sqm), Abergavenny, Monmouthshire, NP7 6HN	Public Open	180sqm	Too small	n/a	n/a	Unsuitable
St Andrews Crescent Amenity Land (2833sqm)	St Andrews Crescent Amenity Land (2833sqm), Abergavenny, Monmouthshire, NP7 6HN	Public Open	2833 sqm	Irregular shape - Too small	n/a	n.a	Unsuitable
St Andrews Crescent, Highways verge	St Andrews Crescent, Highways verge at, Abergavenny, Monmouthshire, NP7 6HN	Public Open	500 sqm	Irregular shape - Too small	n/a	n/a	Unsuitable
St Davids Crescent amenity land	St Davids Crescent amenity land, Llandewi Rhydyderch, Abergavenny, Monmouthshire, NP7 9TR	Public Open	1531 sqm	1531 sqm	n/a	n/a	Childrens Play Area
St Davids Road Amenity Land	St Davids Road Amenity Land, Abergavenny, Monmouthshire, NP7 6HD	Public Open	40 sqm	Too small	n/a	n/a	Unsuitable
St Davids Road Open Space	St Davids Road Open Space, Abergavenny, Monmouthshire, NP7 6HD	Public Open	42 sqm	Too small	n/a	n/a	Unsuitable
St Dials Wood Open Space	St Dials Wood Open Space, Castle Close, Monmouth, Monmouthshire, NP25 5UG	Public Open	1.31 acres	1.31 acres	unknown	unknown	n/a
St Dubricius Gardens (869.2 sq m) Open Space	St Dubricius Gardens (869.2 sq m) Open Space, Undy, Caldicot, Monmouthshire, NP26 3PN	Public Open	869 sqm	869 sqm	n/a	n/a	Next stage
St Faiths Close (319.5 sq m) Open Space	St Faiths Close (319.5 sq m) Open Space, Llanfoist, Abergavenny, Monmouthshire, NP7 9NJ	Public Open	319sqm	Too small	n/a	n/a	Unsuitable
St Faiths Close (512.9 sq m) Open Space	St Faiths Close (512.9 sq m) Open Space, Llanfoist, Abergavenny, Monmouthshire, NP7 9NJ	Public Open	512 sqm	512 sqm	n/a	n/a	Childrens Play Area
St Helens Road Open Space	St Helens Road Open Space, Abergavenny, Monmouthshire, NP7 5UU	Public Open	1139 sqm	1139 sqm	n/a	n/a	Next stage
St Kingsmark Avenue Public Open Space	St Kingsmark Avenue Public Open Space, Chepstow, Monmouthshire, NP16 5ND	Public Open	93 sqm	Too small	n/a	n/a	Unsuitable
St Lawrence Park (262 sq m) Open Space	St Lawrence Park (262 sq m) Open Space, Chepstow, Monmouthshire, NP16 6DP	Public Open	262sqm	Too small	n/a	n/a	Unsuitable
St Lawrence Park (297.2 sq m) Open Space	St Lawrence Park (297.2 sq m) Open Space, Chepstow, Monmouthshire, NP16 6DP	Public Open	297sqm	Too small	n/a	n/a	Unsuitable
St Lawrence Park (644.1 sq m) Open Space	St Lawrence Park (644.1 sq m) Open Space, Chepstow, Monmouthshire, NP16 6DP	Public Open Space	Irregular shape - Too small	Irregular shape - Too small	n/a	n/a	Unsuitable
St Lawrence Road Open Space (1205sqm)	St Lawrence Road Open Space (1205sqm), Bayfield, Chepstow, Monmouthshire, NP16 6DP	Public Open	0.29	Irregular shape - Too small	n/a	n/a	Unsuitable

Google maps shows encroachment or vehicles on site

Not visible on our plans - access constrained

Formal sitting area



St Lawrence Road Open Space (331.7sqm)	St Lawrence Road Open Space (331.7sqm), Bayfield, Chepstow, Monmouthshire, NP16 6DP	Public Open	0.08	too small	n/a	n/a	n/a	Unsuitable
St Stephens Place (166.5 sq m) Open Space	St Stephens Place (166.5 sq m) Open Space, Undy, Caldicot, Monmouthshire, NP26 3PR	Public Open	166sqm	Too small	n/a	n/a	n/a	Unsuitable
St Tysoi Close Public Open Space	St Tysoi Close Public Open Space, Llansoy, Usk, Monmouthshire, NP15 1EF	Public Open	2978 sqm	2978 sqm	unknown	n/a	n/a	Next stage
Stafford Road Public Open Space	Stafford Road Public Open Space, Caldicot, Monmouthshire, NP26 5DE	Public Open	?	Too small	n/a	n/a	n/a	Unsuitable
Starling Close Open Space	Starling Close Open Space, Rogiet, Caldicot, Monmouthshire, NP26 3UU	Public Open	16505 sqm	16505 sqm	Yes - half of site inside f	n/a	n/a	Next stage
Station Road Open Space	Station Road Open Space, Portskewett, Caldicot, Monmouthshire, NP26 5SF	Public Open	430 sqm	Too small	n/a	n/a	n/a	Unsuitable
Station Road Public Open Space	Station Road Public Open Space, Caldicot, Monmouthshire, NP26 4BU	Public Open	630 sqm	630 sqm	n/a	n/a	n/a	Next stage
Station Road, Land adjacent	Station Road, Land adjacent, Station Road, Rogiet, Caldicot, Monmouthshire, NP26 3UF	Public Open	Space	Too small	n/a	n/a	n/a	Unsuitable
Stephens Crescent Amenity Land	Stephens Crescent Amenity Land, Govilon, Abergavenny, Monmouthshire, NP7 9RL	Public Open	4696 sqm	4696 sqm	n/a	n/a	Childrens Play Area	Unsuitable
Stuart Avenue Public Open Space	Stuart Avenue Public Open Space, Chepstow, Monmouthshire, NP16 5NU	Public Open	316 sqm	Too small	n/a	n/a	n/a	Unsuitable
Summerhouse Lane Open Space	Summerhouse Lane Open Space, Chepstow, Monmouthshire, NP16 5SP	Public Open	858 sqm	858 sqm	n/a	n/a	Childrens Play Area	Unsuitable
Sycamore Avenue (1546 sq m) Open Space	Sycamore Avenue (1546 sq m) Open Space, Abergavenny, Monmouthshire, NP7 5JY	Public Open	0.38 acres	n/a	n/a	Woodland	n/a	Unsuitable
Sycamore Avenue (3210 sq m) Open Space	Sycamore Avenue (3210 sq m) Open Space, Abergavenny, Monmouthshire, NP7 5JY	Public Open	0.79 acres	0.79 acres	n/a	Woodland	n/a	Unsuitable
The Claypatch Public Open Space	The Claypatch Public Open Space, Claypatch Road, Wyesham, Monmouth, Monmouthshire	Public Open	0.39 acres	0.39 acres	unknown	Woodland	n/a	Unsuitable
The Cross Public Open Space	The Cross Public Open Space, Sandy Lane, Caldicot, Monmouthshire, NP26 4NR	Public Open	?	Too small	n/a	n/a	n/a	Unsuitable
The Dove Cote Public Open Space	The Dove Cote Public Open Space, Llanfair Discoed, Chepstow, Monmouthshire, NP16 6LX	Public Open	?	Too small	n/a	n/a	n/a	Unsuitable
The Headland (6145 sq m) Public Open Space	The Headland (6145 sq m) Public Open Space, Chepstow, Monmouthshire, NP16 5FA	Public Open	6145 sqm	Irregular shape - Too small	n/a	n/a	n/a	Unsuitable
The Island	The Island, Wyebridge, Monmouth, Monmouthshire, NP25 3LS	Public Open	Space	Too small	Yes	n/a	n/a	Unsuitable
The Limes Open Space	The Limes Open Space, Undy, Magor, Monmouthshire, NP26 3LU	Public Open	36 sqm	Too small	n/a	n/a	n/a	Unsuitable
The Mount, Land at	The Mount, Land at, Off Mount Way, Chepstow, Monmouthshire, NP16 5NF	Public Open	7232 sqm	7232 sqm	n/a	Unfavourable topography	n/a	Unsuitable
The Paddocks Public Open Space	The Paddocks Public Open Space, Undy, Magor, Monmouthshire, NP26 3TD	Public Open	1367 sqm	1367 sqm	n/a	Woodland	n/a	Unsuitable
The Plantation (7314sqm) Open Space	The Plantation (7314sqm) Open Space, Magor, Caldicot, Monmouthshire, NP26 3HR	Public Open	1.80 acres	1.80 acres	n/a	Woodland	n/a	Unsuitable
Toynbee Way Public Open Space	Toynbee Way Public Open Space, Osbaston, Monmouth, Monmouthshire, NP25 3NU	Public Open	780 sqm	780 sqm	unknown	n/a	n/a	Next stage
Tree Tops, Land adjacent	Tree Tops, Land adjacent, Vinegar Hill, Undy, Magor, Monmouthshire, NP26 3EJ	Public Open	282 sqm	Too small	n/a	n/a	n/a	Unsuitable
Trehonddu Open Space (East)	Trehonddu Open Space (East), Llanvihangel Crucorney, Abergavenny, Monmouthshire, NP7 8DG	Public Open	270 sqm	Too small	n/a	n/a	n/a	Unsuitable
Trehonddu Open Space (West)	Trehonddu Open Space (West), Llanvihangel Crucorney, Abergavenny, Monmouthshire, NP7 8DG	Public Open	120 sqm	Too small	n/a	n/a	n/a	Unsuitable
Trelawney Close Public Open Space	Trelawney Close Public Open Space, Usk, Monmouthshire, NP15 1SP	Public Open	0.79 acres	0.79 acres	Yes	Sloped	n/a	Unsuitable
Troy Gardens Open Space	Troy Gardens Open Space, Monmouth, Monmouthshire, NP25 5DB	Public Open	655 sqm	655 sqm	n/a	n/a	Unclear	Next stage
Tudor Road Amenity Land (212.8 sq m)	Tudor Road Amenity Land (212.8 sq m), Wyesham, Monmouth, Monmouthshire, NP25 3LF	Public Open	212sqm	Too small	n/a	n/a	n/a	Unsuitable
Tudor Road Amenity Land (327.5 sq m)	Tudor Road Amenity Land (327.5 sq m), Wyesham, Monmouth, Monmouthshire, NP25 3LF	Public Open	327sqm	Too small	n/a	n/a	n/a	Unsuitable
Tudor Road Amenity Land (90.35 sq m)	Tudor Road Amenity Land (90.35 sq m), Wyesham, Monmouth, Monmouthshire, NP25 3LF	Public Open	90sqm	too small	n/a	n/a	n/a	Unsuitable
Tudor Road Road Open Space	Tudor Road Road Open Space, Wyesham, Monmouth, Monmouthshire, NP25 3LF	Public Open	304 sqm	too small	n/a	n/a	n/a	Unsuitable
Usk View Amenity Land	Usk View Amenity Land, Govilon, Abergavenny, Monmouthshire, NP7 9PD	Public Open	400 sqm	Too Small	n/a	n/a	n/a	Unsuitable
Vauxhall Fields Recreation Area	Vauxhall Fields Recreation Area, Forge Road, Monmouth, Monmouthshire, NP25 3AX	Public Open	21.4 acres	21.4 acres	Yes	n/a	Playing Fields	Unsuitable
Victoria Way Open Space	Victoria Way Open Space, Undy, Magor, Monmouthshire, NP26 3NW	Public Open	Space	Irregular shape - Too small	n/a	n/a	n/a	Unsuitable
Wallis Close Public Open Space	Wallis Close Public Open Space, Osbaston, Monmouth, Monmouthshire, NP25 3NS	Public Open	952 sqm	952 sqm	unknown	n/a	n/a	Next Stage
Wallern Wood Open Space (5114sqm)	Wallern Wood Open Space (5114sqm), Bayfield, Chepstow, Monmouthshire, NP16 5TX	Public Open	5114 sqm	5114 sqm	n/a	n/a	Childrens Play Area	Unsuitable
Warren Slade (Part) Open Space	Warren Slade (Part) Open Space, Adj Denbigh Drive, Chepstow, Monmouthshire, NP16 5SU	Public Open	Space	30491 sqm	n/a	Woodland	n/a	Unsuitable
Warren Slade Open Space	Warren Slade Open Space, Bulwark, Chepstow, Monmouthshire, NP16 5NX	Public Open	Space	34291 sqm	n/a	Woodland	n/a	Unsuitable
Waterside Open Space	Waterside Open Space, Abergavenny, Monmouthshire, NP7 5LJ	Public Open	342 sqm	Too small	n/a	n/a	n/a	Unsuitable
Welsh Street & St Kingsmark (179 sq m)	Welsh Street & St Kingsmark (179 sq m) Public Open Space, Chepstow, Monmouthshire, NP16 5LN	Public Open	179sqm	Too small	n/a	n/a	n/a	Unsuitable
Welsh Street & St Kingsmark (355 sq m)	Welsh Street & St Kingsmark (355 sq m) Public Open Space, Chepstow, Monmouthshire, NP16 5LR	Public Open	355sqm	Too small	n/a	n/a	n/a	Unsuitable
Wentwood View (144 sq m) Open Space	Wentwood View (144 sq m) Open Space, Caldicot, Monmouthshire, NP26 4QH	Public Open	144sqm	Too small	n/a	n/a	n/a	Unsuitable
Wentwood View (162.6 sq m) Open Space	Wentwood View (162.6 sq m) Open Space, Caldicot, Monmouthshire, NP26 4QH	Public Open	162sqm	Too small	n/a	n/a	n/a	Unsuitable
Wentwood View (250.00 sq m) Open Space	Wentwood View (250.00 sq m) Open Space, Caldicot, Monmouthshire, NP26 4QH	Public Open	250sqm	Too small	n/a	n/a	n/a	Unsuitable
Wentwood View (340.6 sq m) Open Space	Wentwood View (340.6 sq m) Open Space, Caldicot, Monmouthshire, NP26 4QH	Public Open	340sqm	Too small	n/a	n/a	n/a	Unsuitable
Wentwood View (487.5 sq m) Open Space	Wentwood View (487.5 sq m) Open Space, Caldicot, Monmouthshire, NP26 4QH	Public Open	487sqm	Too small	n/a	n/a	n/a	Unsuitable
Wentwood View Caldicot Open Space	Wentwood View Caldicot Open Space, Caldicot, Monmouthshire, NP7 9DE	Public Open	10848 sqm	10848 sqm	n/a	n/a	n/a	RLDP CANDIDATE SITE
Westfield Open Space	Westfield Open Space, Caldicot, Monmouthshire, NP26 4HE	Public Open	177 sqm	too small	n/a	n/a	n/a	Unsuitable
Westfield Road Public Open Space	Westfield Road Public Open Space, Osbaston, Monmouth, Monmouthshire, NP25 3HX	Public Open	Space	Irregular shape - Too small	n/a	n/a	n/a	Unsuitable
Whitechapel Walk Open Space	Whitechapel Walk Open Space, Undy, Magor, Monmouthshire, NP26 3NS	Public Open	Space	Too small	n/a	n/a	n/a	Unsuitable
Willow Drive (404.6sqm) Public Open Space	Willow Drive (404.6sqm) Public Open Space, Monmouth, Monmouthshire, NP25 5DW	Public Open	404sqm	too small	n/a	n/a	n/a	Unsuitable
Willow Drive (4708 sq m) Open Space	Willow Drive (4708 sq m) Open Space, Monmouth, Monmouthshire, NP25 5DW	Public Open	4708 sqm	4708 sqm	Yes	na	n/a	Unsuitable
Windsor Close Open Space	Windsor Close Open Space, Magor, Monmouthshire, NP26 3PX	Public Open	475 sqm	Too small	n/a	n/a	na	Unsuitable
Windsor Park Open Space	Windsor Park Open Space, Magor, Monmouthshire, NP26 3NJ	Public Open	560 sqm	560 sqm	n/a	n/a	Childrens Play Area	Unsuitable
Woodland Crescent Open Space	Woodland Crescent Open Space, Woodland Crescent, Llanfoist, Abergavenny, Monmouthshire, NP7 9JZ	Public Open	933 sqm	933 sqm	n/a	n/a	n/a	Next Stage
Woodstock Way Public Open Space	Woodstock Way Public Open Space, Caldicot, Monmouthshire, NP26 5DB	Public Open	Space	Development Site	n/a	n/a	n/a	Unsuitable
Woolpitch Open Space (18390sqm)	Woolpitch Open Space (18390sqm), Bayfield, Chepstow, Monmouthshire, NP16 6DW	Public Open	4.5 acres	4.5 acres	n/a	Sloped - potential for small area	Playing Field	Unsuitable
Woolpitch Wood Open Space (520.2 sqm)	Woolpitch Wood Open Space (520.2 sqm), Bayfield, Chepstow, Monmouthshire, NP16 6DW	Public Open	Space	520 sqm	n/a	n/a	Childrens Play area	Unsuitable
Woolpitch Wood Open Space (54.99sqm)	Woolpitch Wood Open Space (54.99sqm), Chepstow, Monmouthshire, NP16 6DW	Public Open	54sqm	Too small	n/a	n/a	n/a	Unsuitable
Woolpitch Wood Open Space (583.6 sqm)	Woolpitch Wood Open Space (583.6 sqm), Bayfield, Chepstow, Monmouthshire, NP16 6DW	Public Open	Space	583 sqm	n/a	n/a	Childrens Play Area	Unsuitable
Woolpitch Wood Open Space (5846 sqm)	Woolpitch Wood Open Space (5846 sqm), Bayfield, Chepstow, Monmouthshire, NP16 6DW	Public Open	Space	5846 sqm	n/a	Sloped	Playing Fields	Unsuitable
Woolpitch Wood Open Space (59.5sqm)	Woolpitch Wood Open Space (59.5sqm), Chepstow, Monmouthshire, NP16 6DW	Public Open	59sqm	Too small	n/a	n/a	n/a	Unsuitable
Wyebridge Street, Land at	Wyebridge Street, Land at, Monmouth, Monmouthshire, NP25 3DL	Public Open	1642 sqm	1642 sqm	n/a	n/a	n/a	Next Stage
Wyesham Road Open Space	Wyesham Road Open Space, Wyesham, Monmouth, Monmouthshire, NP25 3JR	Public Open	2639 sqm	2639 sqm	n/a	n/a	n/a	Unsuitable
Yew Tree Rise (4972 sq m) Open Space	Yew Tree Rise (4972 sq m) Open Space, Rogiet, Caldicot, Monmouthshire, NP26 3TJ	Public Open	4972 sqm	4972 sqm	n/a	n/a	Childrens Play Area	Unsuitable
Undy Pt2 (0.20 acres)	Undy Pt2 (0.20 acres), Estates Section, @Innovation House P O Box 106, Caldicot, Monmouthshire, NP26 9AN		0.2 acres	0.2 acres	unknown	unknown	unknown	next stage

Planted

Cabinet report for housing development

Desired Size - 500sqm based on requirements for public sites. Pitch = capable of accomodating an amenity block, mobile home, caravan and parking for two vehicles.

Business Unit Name	Postal Address	Description	Area	Larger than 500sqm?	Inside Flood Zone	Constrained by topography?	Existing Play Space? Equipped Play Area or Pitch	Comments
Forge Road, Land adjacent to	Forge Road, Land adjacent to, Osbaston, Monmouth, Monmouthshire	Land	Thin area adjacent	Too small	n/a	n/a	n/a	Unsuitable
Blackrock Picnic Site & Car Park	Blackrock Picnic Site & Car Park, Black Rock Road, Sudbrook, Caldicot, Monmouthshire, NP26 3EJ	Land						
Picnic Site-Beech Hill	Picnic Site-Beech Hill, Chainbridge Road, Usk, Monmouthshire, NP15 1PP	Land	?	Too small	n/a	n/a	n/a	Unsuitable
Picnic Site-Newbridge on Usk	Picnic Site-Newbridge on Usk, Off A449, Llantrissant, Usk, Monmouthshire, NP7 0EB	Land	2.9 acres	2.9 acres	n/a	n/a	n/a	Unsuitable - woodland
Beech Road Playground	Beech Road Playground, Caldicot, Monmouthshire, NP26 4DY	Land	0.6 acres	0.6 acres	n/a	n/a	Childrens Play Area	Unsuitable
Blenheim Avenue Play area	Blenheim Avenue Play area, Magor, Caldicot, Monmouthshire, NP26 3NB	Public Open Space	1.5 acres	6070 sqm	Section of Zone 2 & 3 surface water in western corner		Childrens Play Area on portion of the site	Next stage
Carbonne Close Play Area	Carbonne Close Play Area, Monmouth, Monmouthshire, NP25 5EG	Public Open Space	1.5 acres	6070sqm	Defended Zone 2 rivers		Childrens Play Area on portion of site	Unsuitable - Flood Risk site
Children's play area St Stephens Cres	Children's play area St Stephens Crescent, Govilon, Abergavenny, Monmouthshire	Land	0.3 acres	0.3 acres	n/a	n/a	Childrens Play Area	Unsuitable
Chippenham Mead Playground	Chippenham Mead Playground, Monmouth, Monmouthshire, NP25 3UZ	Land	n/a	n/a	n/a	n/a	Childrens Play Area	Unsuitable
Goldwire Lane Playground	Goldwire Lane Playground, Monmouth, Monmouthshire, NP25 5BG	Land	0.09 acres	Too small	n/a	n/a	n/a	Unsuitable
Hendre Close Playground	Hendre Close Playground, Monmouth, Monmouthshire, NP25 5AX	Land	0.80 acres	0.80 acres	n/a	n/a	Childrens Play Area	Unsuitable
Lawrence Crescent Play area	Lawrence Crescent Play area, Caerwent, Caldicot, Monmouthshire, NP26 5NS	Public Open Space	0.55 acres	2225sqm	No		Childrens Play Area on portion of site	Next stage
Roman Park View Play Area	Roman Park View Play Area, Trelleck, Monmouth, Monmouthshire, NP25 4RB	Land	0.47 acres	0.47 acres	n/a	n/a	Childrens Play Area	Unsuitable
Strongbow Road Play Area	Strongbow Road Play Area, Chepstow, Monmouthshire	Public Open Space	2.1 acres	8498sqm	No		Adjoining allotments	Next Stage
Sycamore Terrace Play Area	Sycamore Terrace Play Area, Magor, Monmouthshire, NP26 3ET	Land	0.47 acres	0.47 acres	n/a	n/a	Childrens Play Area	Unsuitable
The Bryn Play Area	The Bryn Play Area, Abergavenny, Monmouthshire, NP7 9AH	Land	2.6 acres	2.6 acres	Yes	n/a	Childrens Play Area	Unsuitable
Underhill Playing Field Children's Play	Underhill Playing Field Children's Play Area, Abergavenny, Monmouthshire, NP7 6DT	Land		?	n/a	n/a	Childrens Play Area	Unsuitable
Union Road Playground	Union Road Playground, Abergavenny, Monmouthshire	Land	0.35 acres	0.35 acres	n/a	n/a	Childrens Play Area	Unsuitable
Woodland View Play Area	Woodland View Play Area, Monmouth, Monmouthshire, NP25 3JW	Land	0.59 acres	0.59 acres	n/a	n/a	Childrens Play Area.	Unsuitable
Belgrave Road Recreation Ground	Belgrave Road Recreation Ground, Abergavenny, Monmouthshire, NP7 7AD	Public Open Space	5.1 acres	20638sqm	Zone 2 Rivers		Childrens Play area on small portion of land	Unsuitable - Flood Risk of land
Bulwark Park	Bulwark Park, Rockwood Road, Chepstow, Monmouthshire, NP16 5JQ	Land	4.41 acres	4.41 acres	n/a	Sloped	Childrens Play Area	Unsuitable
Cross Ash Playing Field	Cross Ash Playing Field, Graig View, Cross Ash, Abergavenny, Monmouthshire, NP7 8PF	Land	0.6 acres	0.6 acres	n/a	Sloped	Playing Field	Unsuitable
Dingestow Playing Field	Dingestow Playing Field, Monmouth, Monmouthshire, NP25 4JH	Land	1.03 acres	1.03 acres	n/a	Sloped	Childrens Play Area	Unsuitable
Hardwick Recreation Ground	Hardwick Recreation Ground, Hardwick Avenue, Chepstow, Monmouthshire, NP16 5DJ	Land	4.5 acres	4.5 acres	n/a	n/a	Playing Field / Childrens Play Area	Unsuitable
Llanellen King George Playing Fields	Llanellen, Llanellen, Abergavenny, Monmouthshire, NP7 9HN	Land	1.82 acres	1.82 acres	n/a	n/a	Playing Fields	Unsuitable
Llangybi Play Ground	Llangybi Play Ground, St Cybi Avenue, Llangybi, Usk, Monmouthshire, NP15 1TT	Land	0.65 acres	0.65 acres	n/a	n/a	Childrens Play Area	Unsuitable
Llantillio Pertholey Recreation Ground	Llantillio Pertholey Recreation Ground, Off Gwent Road, Mardy, Abergavenny, Monmouthshire	Land	?	?	n/a	n/a	Childrens Play Area / Playing Field	Unsuitable
Llanvapley Recreation Ground	Llanvapley Recreation Ground, Abergavenny, Monmouthshire	Land	4.47 acres	4.47 acres	Yes	n/a	Playing Fields	Unsuitable
Magor Recreation Ground	Magor Recreation Ground, Near Sycamore Terrace, Magor, Monmouthshire	Land	1.49 acres	1.49 acres	Partially	n/a	n/a	Three Fields Site, therefore unsuitable
Main Road , Land at	Main Road , Land at, Undy, Magor, Monmouthshire, NP26 3EH	Land	n/a	n/a	n/a	n/a	n/a	Three Fields Site, therefore unsuitable
Old Hereford Road Playing Field	Old Hereford Road Playing Field, Abergavenny, Monmouthshire, NP7 6EL	Land	1.42 acres	1.42 acres	n/a	n/a	Childrens Play Area	Unsuitable
Penperlleni Recreation Ground	Penperlleni Recreation Ground, Abergavenny, Monmouthshire, NP4 0AJ	Land	1.09 acres	1.09 acres	n/a	n/a	Childrens Play Area	Unsuitable
Recreation area Llanfair Discoed	Recreation area Llanfair Discoed, Adj School Court, Llanvair Discoed, Caldicot, Monmouthshire, NP16 6LX	Land	375 sqm	Too small	n/a	n/a	n/a	Unsuitable
Severn Tunnel Junction, Land & former	Severn Tunnel Junction, Land & former sidings at, Rogiet, Caldicot, Monmouthshire, NP26 3WF	Land?	29 acres	29 acres	Yes - C1 Flood Zone	n/a	n/a	Unsuitable
The Quest Portskewett Playing Field	The Quest Portskewett Playing Field, Caldicot, Monmouthshire, NP26 5PR	Land	7443 sqm	7443 sqm	n/a	n/a	Childrens Play Area/Playing Field	Unsuitable
Thornwell Football Pitch	Thornwell Football Pitch, Denbigh Drive, Chepstow, Monmouthshire	Land	5.21 acres	5.21 acres	n/a	n/a	Playing Fields	Unsuitable
Cwm Clydach, Highway land at	Cwm Clydach, Highway land at, Heads of the Valley Road, Clydach, Abergavenny, Monmouthshire	Highway verge						
Cwm yr Hafod, Highway land at	Cwm yr Hafod, Highway land at, Main Road, Clydach, Abergavenny, Monmouthshire	Highway verge						
Alice Crescent Public Open Space 16	Alice Crescent Public Open Space 1668 sq m, Chepstow, Monmouthshire, NP16 5SW	Public Open Space	0.41 acres	1659sqm	No	Flat		Next stage
Apple Avenue Public Open Space	Apple Avenue Public Open Space, Undy, Caldicot, Monmouthshire, NP26 3QF	Public Open Space	384 sqm	Too small	n/a	n/a	n/a	Unsuitable
Ash Grove Public Open Space	Ash Grove Public Open Space, Caldicot, Monmouthshire, NP26 4NG	Public Open Space	0.22 acres	895 sqm	No	Flat		Next stage
Barnets Wood Open Space (408.7sqm)	Barnets Wood Open Space (408.7sqm), Bayfield, Chepstow, Monmouthshire, NP16 5TN	Public Open Space	0.1 acres	408 sqm	na	n/a	n/a	Unsuitable
Barnets Wood Open Space (530.1sqm)	Barnets Wood Open Space (530.1sqm), Bayfield, Chepstow, Monmouthshire, NP16 5TN	Public Open Space	530 sqm	Too small - irregular shape	n/a	n/a	n/a	Unsuitable
Bayfield Wood Close Open Space (15	Bayfield Wood Close Open Space (155.2 sqm), Bayfield, Chepstow, Monmouthshire, NP16 6FB	Public Open Space	0.03 acres	Too small	n/a	n/a	n/a	Unsuitable

Bayfield Wood Close Open Space (727.5 sqm)	Bayfield Wood Close Open Space (727.5 sqm), Bayfield, Chepstow, Monmouthshire, NP16 6FB	Public Open Space	727 sqm	727 sqm	n/a	n/a	Childrens Play Area	Unsuitable
Bayfield Wood playground & Open Space (6763sqm)	Bayfield Wood playground & Open Space (6763sqm), Bayfield, Chepstow, Monmouthshire, NP16 6FB	Public Open Space	1.6 acres	1.6 acres	n/a	n/a	Childrens Play Area	Unsuitable
Beaupreau Place Public Open Space	Beaupreau Place Public Open Space, Abergavenny, Monmouthshire, NP7 5LZ	Public Open Space	1.53 acres	6191sqm	Small area Zone 3 Rivers in northern section of site but could be excluded		Woodland	Next stage
Bigham Close Public Open Space	Bigham Close Public Open Space, Monmouth, Monmouthshire, NP25 5DP	Public Open Space	0.3	1278sqm	Approximately half of site is Zone 2 Rivers		Adjoins a Childrens Play Area	Next Stage
Bishops Close (4277 sq m) Public Open Space	Bishops Close (4277 sq m) Public Open Space, Chepstow, Monmouthshire, NP16 5TE	Public Open Space	1.05 acres	4229sqm	No	Sloped in various places. Potential for smaller plot to be created on portion		Next stage
Blenheim Avenue Public Open Space	Blenheim Avenue Public Open Space, Magor, Caldicot, Monmouthshire, NP26 3NB	Public Open Space	1.56 acres	1.56 acres	n/a	n/a	Play Area	Unsuitable
Blestium Drive Open Space, Usk, Monmouthshire	Blestium Drive Open Space, Usk, Monmouthshire	Public Open Space	445 sqm	Too small	n/a	n/a	n/a	Unsuitable
Burrium Gate Open Space	Burrium Gate Open Spce, Usk, Monmouthshire	Public Open Space	728 sqm	728 sqm	Yes	n/a	n/a	Unsuitable
Cae Derw Public Open Space (1130sqm)	Cae Derw Public Open Space (1130sqm), Gilwern, Abergavenny, Monmouthshire, NP7 0BJ	Public Open Space	0.27 acres	1092sqm	No			Next stage
Cae Derw Public Open Space (701 sqm)	Cae Derw Public Open Space (701 sqm), Gilwern, Abergavenny, Monmouthshire, NP7 0BJ	Public Open Space	0.17 acres	687sqm	No			Next stage
Cae Melin (1104 sq m) Open Space	Cae Melin (1104 sq m) Open Space, Little Mill, Pontypool, NP4 0HX	Public Open Space	0.27 acres	1104 sqm	n/a	n/a	Childrens Play Area	Unsuitable
Caerwent Lane (3615 sq m) Public Open Space	Caerwent Lane (3615 sq m) Public Open Space, Chepstow, Monmouthshire, NP16 5TQ	Public Open Space	0.89 acres	3601sqm	Zone 3 Surface Water on most of site		Woodland	Next Stage
Caerwent Lane (69.22 sqm) Open Space	Caerwent Lane (69.22sqm) Open Space, Thornwell, Chepstow, Monmouthshire, NP16 5TQ	Public Open Space	0.01 acres	Too small	n/a	n/a	n/a	Unsuitable
Cassia Drive Open Space	Cassia Drive Open Space, Usk, Monmouthshire	Public Open Space	0.5 acres	0.5 acres	n/a	n/a	Play Area	Unsuitable
Castle Wood Open Space (678.1sqm)	Castle Wood Open Space (678.1sqm), Bayfield, Chepstow, Monmouthshire, NP16 5TZ	Public Open Space	0.16 acres	678 sqm	n/a	n/a	Childrens Play Area	Unsuitable
Caxton Court Public Open Space	Caxton Court Public Open Space, Monmouth, Monmouthshire, NP25 5DJ	Public Open Space	305 sqm	Too small	n/a	n/a	n/a	Unsuitable
Chaucer Way Public Open Space	Chaucer Way Public Open Space, Osbaston, Monmouth, Monmouthshire, NP25 3NR	Public Open Space	144 sqm	Too small	n/a	n/a	n/a	Unsuitable
Church Rise Public Open Space	Church Rise Public Open Space, Undy, Caldicot, Monmouthshire, NP26 3NR	Public Open Space	91 sqm	Too small	n/a	n/a	n/a	Unsuitable
Church Road Public Open Space	Church Road Public Open Space, Church Road, Caldicot, Monmouthshire	Public Open Space	0.7 acres	2832sqm	Small area in Zone 3 Sea in eastern section of site but could be excluded			Next stage
Clearview Court (103.2 sq m) Public Open Space	Clearview Court (103.2 sq m) Public Open Space, Shirenewton, Chepstow, Monmouthshire	Public Open Space	0.02	Highways and too small	n/a	n/a	n/a	Unsuitable
Clearview Court (129.2 sq m) Public Open Space	Clearview Court (129.2 sq m) Public Open Space, Shirenewton, Chepstow, Monmouthshire	Public Open Space	0.03	Too small	n/a	n/a	n/a	Unsuitable
Clearview Court (14.09 sq m) Public Open Space	Clearview Court (14.09 sq m) Public Open Space, Shirenewton, Chepstow, Monmouthshire	Public Open Space	0.003	Too small	n/a	n/a	n/a	Unsuitable
Clearview Court (275.3 sq m) Public Open Space	Clearview Court (275.3 sq m) Public Open Space, Shirenewton, Chepstow, Monmouthshire	Public Open Space	0.06	Too small	n/a	n/a	n/a	Unsuitable
Clearview Court (321.9 sq m) Public Open Space	Clearview Court (321.9 sq m) Public Open Space, Shirenewton, Chepstow, Monmouthshire	Public Open Space	0.07	Too small	n/a	n/a	n/a	Unsuitable
Clearview Court (36.49 sq m) Public Open Space	Clearview Court (36.49 sq m) Public Open Space, Shirenewton, Chepstow, Monmouthshire	Public Open Space	0.008	Too small	n/a	n/a	n/a	Unsuitable
Clearview Court (39.31 sq m) Public Open Space	Clearview Court (39.31 sq m) Public Open Space, Shirenewton, Chepstow, Monmouthshire	Public Open Space	0.009	Too small	n/a	n/a	n/a	Unsuitable
Clearview Court (42.03 sq m) Public Open Space	Clearview Court (42.03 sq m) Public Open Space, Shirenewton, Chepstow, Monmouthshire	Public Open Space	0.009	Too small	n/a	n/a	n/a	Unsuitable
Clearview Court (204.7 sq m) Public Open Space	Clearview Court (204.7 sq m) Public Open Space, Shirenewton, Chepstow, Monmouthshire, NP16 6AX	Public Open Space	0.05	Too small	n/a	n/a	n/a	Unsuitable
Clos Alwen Public Open Space & Playground	Clos Alwen Public Open Space & Playground, Clos Alwen, Caldicot, Monmouthshire	Public Open Space	1000 sqm	1000sqm	n/a	n/a	Childrens Play Area	Unsuitable
Clos Rheidol Public Open Space	Clos Rheidol Public Open Space, Caldicot, Monmouthshire, NP26 4JD	Public Open Space	233 sqm	Too small	n/a	n/a	n/a	Unsuitable
Cobb Crescent Public Open Space	Cobb Crescent Public Open Space, Caldicot, Monmouthshire, NP26 5BY	Public Open Space	0.13 acres	551 sqm	No			Next stage
Cornford Close Public Open Space	Cornford Close Public Open Space, Osbaston, Monmouth, Monmouthshire, NP25 3NT	Public Open Space	560 sqm	560 sqm	?	Sloped? - no clear access	n/a	Unsuitable
Cornwallis Way Public Open Space	Cornwallis Way Public Open Space, Monmouth, Monmouthshire, NP25 5DN	Public Open Space	369 sqm	369 sqm	n/a	n/a	n/a	Unsuitable

Courthouse Road Public Open Space	Courthouse Road Public Open Space, Llanvair Discoed, Chepstow, Monmouthshire	Public Open Space	3400 sqm	3000 sqm but irregular shape	n/a	n/a	n/a	Unsuitable
Cresta Road (153.8 sq m) Open Space	Cresta Road (153.8 sq m) Open Space, Abergavenny, Monmouthshire, NP7 7AU	Public Open Space	0.03	Too small	n.a	n/a	n/a	Unsuitable
Cresta Road (321.5 sq m) Open Space	Cresta Road (321.5 sq m) Open Space, Abergavenny, Monmouthshire, NP7 7AU	Public Open Space	0.07	Too small	n.a	n/a	n/a	Unsuitable
Croesonen Gardens Open Space (104sqm)	Croesonen Gardens Open Space (104sqm), Abergavenny, Monmouthshire, NP7 6BJ	Public Open Space	0.02	Too small	n.a	n/a	n/a	Unsuitable
Croesonen Gardens Open Space (571sqm)	Croesonen Gardens Open Space (571sqm), Abergavenny, Monmouthshire, NP7 6BJ	Public Open Space	571 sqm	571 sqm - irregular shape	n/a	n/a	n/a	Unsuitable
Cybi Avenue Open Space	Cybi Avenue Open Space, Llangybi, Usk, Monmouthshire, NP15 1TU	Public Open Space		Too small	n/a	n/a	n/a	Unsuitable
Cybi Drive Open Space	Cybi Drive Open Space, Llangybi, Usk, Monmouthshire, NP15 1TU	Public Open Space	0.19 acres	796 sqm	No	Flat		Next stage
Cybi Rise Open Space	Cybi Rise Open Space, Llangybi, Usk, Monmouthshire, NP15 1TU	Public Open Space	0.16 acres	672 sqm	No	Flat		Next stage
Delafield Road (2007 sq m) Open Space	Delafield Road (2007 sq m) Open Space, Abergavenny, Monmouthshire, NP7 7AW	Public Open Space	0.49	2007 sqm	?	Unfavourable topography	n/a	Unsuitable
Delafield Road (2803 sq m) Open Space	Delafield Road (2803 sq m) Open Space, Abergavenny, Monmouthshire, NP7 7AW	Public Open Space	0.69	2803 sqm	?	Sloped, unfavourable topography in all but one small area, therefore unsuitable	n/a	Unsuitable
Delafield Road (47.01sq m) Open Space	Delafield Road (47.01sq m) Open Space, Abergavenny, Monmouthshire, NP7 7AW	Public Open Space	0.01	Too small	n/a	n/a	n/a	Unsuitable
Dunlin Avenue Public Open Space	Dunlin Avenue Public Open Space, Caldicot, Monmouthshire, NP26 5DL	Public Open Space	402 sqm	Too small	n/a	n/a	n/a	Unsuitable
Fedw Wood Open Space (3977sqm)	Fedw Wood Open Space (3977sqm), Bayfield, Chepstow, Monmouthshire, NP16 5TW	Public Open Space	0.98	0.98 acres	?	Area of woodland	n/a	Unsuitable
Ferney Cross Public Open Space	Ferney Cross Public Open Space, Longfellow Road, Caldicot, Monmouthshire, NP26 4QY	Public Open Space	0.79 acres	3200 sqm	Zone 3 Sea	Flat		Unsuitable - Flood Risk
Fountain Way (1478 sq m) Public Open Space	Fountain Way (1478 sq m) Public Open Space, Chepstow, Monmouthshire, NP16 5SZ	Public Open Space	0.365 acres	1478 sqm	No			Next stage
Green Moor Lane Public Open Space	Green Moor Lane Public Open Space, Magor, Caldicot, Monmouthshire, NP26 3NB	Public Open Space	70 sqm	Too small	n/a	n/a	n/a	Unsuitable
Greenlands Close Public Open Space	Greenlands Close Public Open Space, Wyesham, Monmouth, Monmouthshire, NP25 3LP	Public Open Space	1064 sqm	1064 sqm	?	Woodland	n/a	Unsuitable
Greenmeadow Crescent Public Open Space	Greenmeadow Crescent Public Open Space, Little Mill, Usk, Monmouthshire	Public Open Space	1048 sqm	1048 sqm	n/a	n/a	Childrens Play Area	Unsuitable
Hamilton Way Open Space (1244sqm)	Hamilton Way Open Space (1244sqm), Monmouth, Monmouthshire, NP25 5BY	Public Open Space	1244 sqm	1244 sqm	n/a	Woodland	n/a	Unsuitable
Heol Teifi Public Open Space & Playground	Heol Teifi Open Space & Playground (2 parcels) 15540sqm, Caldicot, Monmouthshire	Public Open Space	3.8	3.8 acres	n/a	n/a	Childrens Play Area	Unsuitable
Heol Teifi Public Open Space & Playground	Heol Teifi Public Open Space & Playground (2 parcels) 882.3 sqm, Heol Teifi, Caldicot, Monmouthshire	Public Open Space	0.21	0.21 acres	n/a	n/a	Childrens Play Area	Unsuitable
Heol Towy Public Open Space & Playground	Heol Towy Public Open Space & Playground, Heol Towy, Caldicot, Monmouthshire	Public Open Space	n/a	n/a	n/a	n/a	Childrens Play Area	Unsuitable
Jordans Way Public Open Space	Jordans Way Public Open Space, Monmouth, Monmouthshire, NP25 5EA	Public Open Space	397 sqm	397 sqm	n/a	n/a	n/a	Unsuitable
Kensington Park (415 sq m) Public Open Space	Kensington Park (415 sq m) Public Open Space, Magor, Caldicot, Monmouthshire, NP26 3QH	Public Open Space	0.1	Too small	n/a	n/a	n/a	Unsuitable
Kensington Park (729 sq m) Public Open Space	Kensington Park (729 sq m) Public Open Space, Magor, Caldicot, Monmouthshire, NP26 3QH	Public Open Space	0.18 acres	729 sqm	Zone 3 Sea Defended			Unsuitable - Flood Risk
Kingsmark Lane (222 sq m) Public Open Space	Kingsmark Lane (222 sq m) Public Open Space, Chepstow, Monmouthshire, NP16 5LZ	Public Open Space	0.05	Too Small	n.a	n/a	n/a	Unsuitable
Kingsmark Lane (242 sq m) Public Open Space	Kingsmark Lane (242 sq m) Public Open Space, Chepstow, Monmouthshire, NP16 5LZ	Public Open Space	0.06	Too Small	n/a	n/a	n/a	Unsuitable
Lancaster Way Public Open Space	Lancaster Way Public Open Space, Osbaston, Monmouth, Monmouthshire, NP25 3BE	Public Open Space	1.22 acres	4943 sqm	Zone 3 Surface Water running along northern boundary	Sloping - potential for smaller plot		Next stage
Levitsfield Close Open Space (1255sqm)	Levitsfield Close Open Space (1255sqm), Monmouth, Monmouthshire, NP25 5BZ	Public Open Space		Irregular shape - Too small	n/a	n/a	n/a	Unsuitable
Levitsfield Close Public Open Space	Levitsfield Close Public Open Space, Monmouth, Monmouthshire, NP25 5BZ	Public Open Space		Too small	n/a	n/a	n/a	Unsuitable
Linnet Road Public Open Space	Linnet Road Public Open Space, Caldicot, Monmouthshire, NP26 5DJ	Public Open Space	424 sqm	Too small	n/a	n/a	n/a	Unsuitable
Longfellow Close Public Open Space	Longfellow Close Public Open Space, Caldicot, Monmouthshire, NP26 4LD	Public Open Space	239 sqm	Too small	n/a	n/a	n/a	Unsuitable
Newport Road Public Open Space	Newport Road Public Open Space, Adj Westfield, Caldicot, Monmouthshire, NP26 4AE	Public Open Space	35 sqm	Too small	n/a	n/a	n/a	Unsuitable
Nightingale Close Public Open Space	Nightingale Close Public Open Space, Caldicot, Monmouthshire, NP26 5ES	Public Open Space	415 sqm	Too small	n/a	n/a	n/a	Unsuitable

Normandy Way Public Open Space	Normandy Way Public Open Space, Chepstow, Monmouthshire, NP16 5NB	Public Open Space	2 acres	2 acres	?	Sloped	n.a	Unsuitable
Orchid Drive Open Space	Orchid Drive Open Space, Undy, Magor, Monmouthshire, NP26 5GE	Public Open Space	3.4 acres	14,500 sqm	No		Childrens equipped play area on small area	Next stage
Plas Mynydd Open Space	Plas Mynydd Open Space, Llanfoist, Abergavenny, Monmouthshire, NP7 9FJ	Public Open Space	432 sqm	Too small	n/a	n/a	n/a	Unsuitable
Priory Close Public Open Space	Priory Close Public Open Space, Chepstow, Monmouthshire, NP16 5ND	Public Open Space	81 sqm	Too small	n/a	n/a	n/a	Unsuitable
Rushey Meadow Public Open Space	Rushey Meadow Public Open Space, Monmouth, Monmouthshire, NP25 5BT	Public Open Space	?	Irregular shape - Too small	n/a	n/a	n/a	Unsuitable
Samuel Rodgers Crescent (155.8sqm)	Samuel Rodgers Crescent (155.8sqm) Open Space, Thornwell, Chepstow, Monmouthshire, NP16 5GB	Public Open Space	0.03	Too small	n/a	n/a	n/a	Unsuitable
Samuel Rodgers Crescent (162.8sqm)	Samuel Rodgers Crescent (162.8sqm) Open Space, Thornwell, Chepstow, Monmouthshire, NP16 5GB	Public Open Space	0.04	Too small	n/a	n/a	n/a	Unsuitable
Shelley Close Public Open Space	Shelley Close Public Open Space, Caldicot, Monmouthshire, NP26 4LQ	Public Open Space	0.26 acres	1085 sqm	Zone 3 Sea			Unsuitable - Flood risk
St Kingsmark Avenue Public Open Space	St Kingsmark Avenue Public Open Space, Chepstow, Monmouthshire, NP16 5ND	Public Open Space	93 sqm	Too small	n/a	n/a	n/a	Unsuitable
St Lawrence Road Open Space (1205sqm)	St Lawrence Road Open Space (1205sqm), Bayfield, Chepstow, Monmouthshire, NP16 6DP	Public Open Space	0.29	Irregular shape - Too small	n/a	n/a	n/a	Unsuitable
St Lawrence Road Open Space (331.7sqm)	St Lawrence Road Open Space (331.7sqm), Bayfield, Chepstow, Monmouthshire, NP16 6DP	Public Open Space	0.08	too small	n/a	n/a	n/a	Unsuitable
St Tysoi Close Public Open Space	St Tysoi Close Public Open Space, Llansoy, Usk, Monmouthshire, NP15 1EF	Public Open Space	0.72 acres	2978 sqm	No		Trees covering site	Next stage
Stafford Road Public Open Space	Stafford Road Public Open Space, Caldicot, Monmouthshire, NP26 5DE	Public Open Space	?	Too small	n/a	n/a	n/a	Unsuitable
Station Road Public Open Space	Station Road, Caldicot	Public Open Space	0.15 acres	630 sqm	Zone 3 Sea			Unsuitable - Flood risk
Stuart Avenue Public Open Space	Stuart Avenue Public Open Space, Chepstow, Monmouthshire, NP16 5NU	Public Open Space	316 sqm	Too small	n/a	n/a	n/a	Unsuitable
The Claypatch Public Open Space	The Claypatch Public Open Space, Claypatch Road, Wyesham, Monmouth, Monmouthshire	Public Open Space	0.39 acres	0.39 acres	?	Woodland	n/a	Unsuitable
The Cross Public Open Space	The Cross Public Open Space, Sandy Lane, Caldicot, Monmouthshire, NP26 4NR	Public Open Space	?	Too small	n/a	n/a	n/a	Unsuitable
The Dove Cote Public Open Space	The Dove Cote Public Open Space, Llanfair Discoed, Chepstow, Monmouthshire, NP16 6LX	Public Open Space	?	Too small	n/a	n/a	n/a	Unsuitable
The Headland (6145 sq m) Public Open Space	The Headland (6145 sq m) Public Open Space, Chepstow, Monmouthshire, NP16 5FA	Public Open Space	6145 sqm	Irregular shape - Too small	n/a	n/a	n/a	Unsuitable
The Paddocks Public Open Space	The Paddocks Public Open Space, Undy, Magor, Monmouthshire, NP26 3TD	Public Open Space	1367 sqm	1367 sqm	n/a	Woodland	n.a	Unsuitable
Toynbee Way Public Open Space	Toynbee Way Public Open Space, Osbaston, Monmouth, Monmouthshire, NP25 3NU	Public Open Space	0.19 acres	780 sqm	No			Next stage
Trelawney Close Public Open Space	Trelawney Close Public Open Space, Usk, Monmouthshire, NP15 1SP	Public Open Space	0.79 acres	0.79 acres	Yes	Sloped	n/a	Unsuitable
Wallis Close Public Open Space	Wallis Close Public Open Space, Osbaston, Monmouth, Monmouthshire, NP25 3NS	Public Open Space	0.23 acres	952 sqm	No			Next Stage
Wallwern Wood Open Space (5114sqm)	Wallwern Wood Open Space (5114sqm), Bayfield, Chepstow, Monmouthshire, NP16 5TX	Public Open Space	5114 sqm	5114 sqm	n/a	n/a	Childrens Play Area	Unsuitable
Welsh Street & St Kingsmark (179 sq m)	Welsh Street & St Kingsmark (179 sq m) Public Open Space, Chepstow, Monmouthshire, NP16 5LN	Public Open Space	179sqm	Too small	n/a	n/a	n/a	Unsuitable
Welsh Street & St Kingsmark (355 sq m)	Welsh Street & St Kingsmark (355 sq m) Public Open Space, Chepstow, Monmouthshire, NP16 5LR	Public Open Space	355sqm	Too small	n/a	n/a	n/a	Unsuitable
Wentwood View (144 sq m) Open Space	Wentwood View (144 sq m) Open Space, Caldicot, Monmouthshire, NP26 4QH	Public Open Space	144sqm	Too small	n/a	n/a	n/a	Unsuitable
Wentwood View (162.6 sq m) Open Space	Wentwood View (162.6 sq m) Open Space, Caldicot, Monmouthshire, NP26 4QH	Public Open Space	162sqm	Too small	n/a	n/a	n/a	Unsuitable
Wentwood View (250.00 sq m) Open Space	Wentwood View (250.00 sq m) Open Space, Caldicot, Monmouthshire, NP26 4QH	Public Open Space	250sqm	Too small	n/a	n/a	n/a	Unsuitable
Wentwood View (340.6 sq m) Open Space	Wentwood View (340.6 sq m) Open Space, Caldicot, Monmouthshire, NP26 4QH	Public Open Space	340sqm	Too small	n/a	n/a	n/a	Unsuitable
Wentwood View (487.5 sq m) Open Space	Wentwood View (487.5 sq m) Open Space, Caldicot, Monmouthshire, NP26 4QH	Public Open Space	487sqm	Too small	n/a	n/a	n/a	Unsuitable
Westfield Road Public Open Space	Westfield Road Public Open Space, Osbaston, Monmouth, Monmouthshire, NP25 3HX	Public Open Space		Irregular shape - Too small	n/a	n/a	n/a	Unsuitable
Windsor Close Open Space	Windsor Close Open Space, Magor, Monmouthshire, NP26 3PX	Public Open Space	475 sqm	Too small	n/a	n/a	na	Unsuitable
Windsor Park Open Space	Windsor Park Open Space, Magor, Monmouthshire, NP26 3NJ	Public Open Space	560 sqm	560 sqm	n/a	n/a	Childrens Play Area	Unsuitable
Woodstock Way Public Open Space	Woodstock Way Public Open Space, Caldicot, Monmouthshire, NP26 5DB	Public Open Space		Development Site	n/a	n/a	n/a	Unsuitable

Woolpitch Open Space (18390sqm)	Woolpitch Open Space (18390sqm), Bayfield, Chepstow, Monmouthshire, NP16 6DW	Public Open Space	4.5 acres	4.5 acres	?	Sloped - potential for small area	Playing Field	Unsuitable
Woolpitch Wood Open Space (54.99sqm)	Woolpitch Wood Open Space (54.99sqm), Chepstow, Monmouthshire, NP16 6DW	Public Open Space	54sqm	Too small	n/a	n/a	n/a	Unsuitable
Woolpitch Wood Open Space (59.5sqm)	Woolpitch Wood Open Space (59.5sqm), Chepstow, Monmouthshire, NP16 6DW	Public Open Space	59sqm	Too small	n/a	n/a	n/a	Unsuitable
63 Tudor Street, Land adjacent to	Tudor Street, Land adjacent to 63, Abergavenny, Monmouthshire, NP7 5DL	Public Open Space	185 sqm	Too small	n/a	n/a	n/a	Unsuitable
A4077 Crickhowell Road (2849 sq m)	A4077 Crickhowell Road (2849 sq m), Land, Gilwern, Abergavenny, Monmouthshire, NP7 0EH	Public Open Space	2849 sqm	2849 sqm	n/a	Woodland	n/a	Unsuitable
Abergavenny Castle, Land adjacent	Abergavenny Castle, Land adjacent, Mill Street, Abergavenny, Monmouthshire	Public Open Space	?	Public site. Castle grounds	n/a	n/a	n/a	Unsuitable
Alcove Wood Open Space (1106 sqm)	Alcove Wood Open Space (1106 sqm), Bayfield, Chepstow, Monmouthshire, NP16 6DT	Public Open Space	1106 sqm	1106 sqm	n/a	na	Childrens Play Area	Unsuitable
Alcove Wood Open Space (670.6 sqm)	Alcove Wood Open Space (670.6 sqm), Bayfield, Chepstow, Monmouthshire, NP16 6DT	Public Open Space	670 sqm	670 sqm	n/a	n/a	Childrens Play Area	Unsuitable
Baker Street Open Space	Baker Street Open Space, Abergavenny, Monmouthshire, NP7 5BB	Public Open Space	372 sqm	Too small	n/a	na	n/a	Unsuitable
Barn Owl Road Open Space	Barn Owl Road Open Space, Rogiet, Caldicot, Monmouthshire, NP26 3UL	Public Open Space	731 sqm	Irregular shape - Too small	n/a	n/a	n/a	Unsuitable
Bay Tree Lane (4505 sq m) Open Space	Bay Tree Lane (4505 sq m) Open Space, Abergavenny, Monmouthshire, NP7 5JW	Public Open Space	4505 sqm	4505 sqm	n/a	n/a	Play Area	Unsuitable
Beaupreau Place Open Space	Beaupreau Place Open Space, Abergavenny, Monmouthshire, NP7 5LZ	Public Open Space	5493 sqm	5493 sqm	Yes	n/a	n/a	Unsuitable
Berryfield Close Open Space	Berryfield Close Open Space, Osbaston, Monmouth, Monmouthshire, NP25 3JG	Public Open Space	0.29 acres	1185 sqm	No			Next stage
Bigham Close (1233 sq m) Open Space	Bigham Close (1233 sq m) Open Space, Monmouth, Monmouthshire, NP25 5DP	Public Open Space	1233 sqm	1233 sqm	?	Planting	n/a	Unsuitable
Birbeck Road Open Space	Birbeck Road Open Space, Caldicot, Monmouthshire, NP26 4DX	Public Open Space	?	Too small. Residential street	n/a	n/a	n/a	Unsuitable
Birch Close Open Space	Birch Close Open Space, Undy, Magor, Monmouthshire, NP26 3LW	Public Open Space	160 sqm	Too small	n/a	n/a	n/a	Unsuitable
Blethyn Close Open Space	Blethyn Close Open Space, Shirenewton, Chepstow, Monmouthshire, NP16 6SW	Public Open Space	3.57 acres	14466 sqm	No			Next stage
Briar Close Open Space	Briar Close Open Space, Undy, Magor, Monmouthshire, NP26 3LQ	Public Open Space	308 sqm	Too small	n/a	n/a	n/a	Unsuitable
Broadstone Terrace/Rocks Close Open Space	Broadstone Terrace/Rocks Close Open Space, Catbrook, Monmouth, Monmouthshire, NP16 6NE	Public Open Space	?	Residential street	n/a	n/a	n/a	Unsuitable
Brookside Open Space	Brookside Open Space, Neddern Way, Caldicot, Monmouthshire, NP26 4NJ	Public Open Space	3.59 acres	14539 sqm	No			Next stage
Brynawr Estate, Filter Bed & Amenity Land	Brynawr Estate, Filter Bed & Amenity Land, Cwmyoy, Abergavenny, Monmouthshire, NP7 7ND	Public Open Space	3037 sqm	3037 sqm	n/a	Woodland	n/a	Unsuitable
Brynteg Place Amenity Land	Brynteg Place Amenity Land, Little Mill, Pontypool, Torfaen, NP4 OHA	Public Open Space	258 sqm	Too small	n/a	n/a	n/a	Unsuitable
Budden Crescent Open Space	Budden Crescent Open Space, Caldicot, Monmouthshire, NP26 4QB	Public Open Space	233 sqm	Too small	n/a	n/a	n/a	Unsuitable
Bulwark Road Open Space	Bulwark Road Open Space, Caldicot, Monmouthshire, NP16 5JQ	Public Open Space	457 sqm	Too small	n.a	n/a	n/a	Unsuitable
Bushy Close, Land at	Bushy Close, Land at, Portskewett, Caldicot, Monmouthshire, NP26 5TR	Public Open Space	1019 sqm	Irregular shape - Too small	n/a	n/a	n/a	Unsuitable
Buzzard Close Open Space	Buzzard Close Open Space, Monmouth, Monmouthshire, NP26 3UY	Public Open Space	456 sqm	Too small	n/a	n/a	n/a	Unsuitable
Cadoc Close (110.5 sq m) Open Space	Cadoc Close (110.5 sq m) Open Space, Caerwent, Caldicot, Monmouthshire, NP26 4QT	Public Open Space	110sqm	Too small	n/a	n/a	n/a	Unsuitable
Cadoc Close (82.74 sq m) Open Space	Cadoc Close (82.74 sq m) Open Space, Caerwent, Caldicot, Monmouthshire, NP26 4QT	Public Open Space	82sqm	Too small	na	n/a	n/a	Unsuitable
Cae-pen-y-dre Close, Land at	Cae-pen-y-dre Close, Land at, Abergavenny, Monmouthshire, NP7 5UR	Public Open Space	1422 sqm	1422 sqm	n/a	Sloped - planting	n/a	Unsuitable
Caldicot Levels, Land forming part of	Caldicot Levels, Land forming part of, Sudbrook, Caldicot, Monmouthshire, NP26 5TW	Public Open Space	23 acres	23 acres	Yes	n/a	n/a	Unsuitable
Cappers Place Amenity Land	Cappers Place Amenity Land, Monmouth, Monmouthshire, NP25 5AL	Public Open Space	499 sqm	Too small	n/a	n/a	n/a	Unsuitable
Castle Meadows, Land at	Castle Meadows, Land at, Abergavenny, Monmouthshire, NP7 7RZ	Public Open Space	49 acres	49 acres	?	n/a	n/a	Unsuitable
Castle Oak (1154 sq m) Open Space	Castle Oak (1154 sq m) Open Space, Usk, Monmouthshire, NP15 1SG	Public Open Space	1154 sqm	1154 sqm	Yes	n/a	n/a	Unsuitable
Castle Oak (842.9 sq m) Open Space	Castle Oak (842.9 sq m) Open Space, Usk, Monmouthshire, NP15 1SG	Public Open Space	0.20 acres	842 sqm	No			Next stage
Charles Edwards Close (661.4 sq m) Open Space	Charles Edwards Close (661.4 sq m) Open Space, Llanfoist, Abergavenny, Monmouthshire, NP7 9NQ	Public Open Space	661 sqm	Too small - footpath and bus	n/a	n/a	n/a	Unsuitable

Chepstow Road Open Space	Chepstow Road Open Space, Trellech, Monmouth, Monmouthshire, NP25 4PE	Public Open Space	253 sqm	Too small	n/a	n/a	n/a	Unsuitable
Chestnut Close open Space	Chestnut Close open Space, Magor, Caldicot, Monmouthshire, NP7 5JZ	Public Open Space	48 sqm	Too small	n/a	n/a	n/a	Unsuitable
Chestnut Drive (1270 sq m) Open Space	Chestnut Drive (1270 sq m) Open Space, Rogiet, Caldicot, Monmouthshire, NP7 5JZ	Public Open Space	0.31 acres	1270 sqm	Zone 3 Sea			Unsuitable - Flood risk
Chestnut Drive (1423 sq m) Open Space	Chestnut Drive (1423 sq m) Open Space, Abergavenny, Monmouthshire, NP7 5JZ	Public Open Space	1423 sqm	1423 sqm	n/a	Sloped	n/a	Unsuitable
Chestnut Drive (180 sq m) Open Space	Chestnut Drive (180 sq m) Open Space, Rogiet, Caldicot, Monmouthshire, NP7 5JZ	Public Open Space	180sqm	Too Small	n/a	n/a	n/a	Unsuitable
Chestnut Drive (268.2 sq m) Open Space	Chestnut Drive (268.2 sq m) Open Space, Rogiet, Caldicot, Monmouthshire, NP7 5JZ	Public Open Space	268sqm	Too Small	n/a	n/a	n/a	Unsuitable
Chestnut Drive (703 sq m) Open Space	Chestnut Drive (703 sq m) Open Space, Rogiet, Caldicot, Monmouthshire, NP7 5JZ	Public Open Space	0.17 acres	703 sqm	Zone 3 Sea & Zone 3 Surface Water			Unsuitable - Flood risk
Churchmead Open Space	Churchmead Open Space, Rogiet, Caldicot, Monmouthshire, NP26 3TG	Public Open Space	98 sqm	Too small	n/a	n/a	n/a	Unsuitable
Cinderhill Street Amenity Land	Cinderhill Street Amenity Land, Monmouth, Monmouthshire, NP25 5EY	Public Open Space	?	Too small	n/a	n/a	n/a	Unsuitable
Clos Croeso Amenity Land	Clos Croeso Amenity Land, Usk, Monmouthshire, NP15 1AZ	Public Open Space	167 sqm	Too small	n/a	n/a	n/a	Unsuitable
Clos Rheidol Public Open Space (4 parcels)	Clos Rheidol Open Space (4 parcels), Clos Rheidol, Caldicot, Monmouthshire	Public Open Space	450 sqm	Too small	n/a	n/a	n/a	Unsuitable
Clydach Villa, Land adjacent to	Clydach Villa, Land adjacent to, Church Road, Clydach, Abergavenny, Monmouthshire, NP7 0LF	Public Open Space	1367 sqm	1367 sqm	?	Unclear - appears to be woodland	n/a	Unsuitable
Conigar Crescent Open Space	Conigar Crescent Open Space, Usk, Monmouthshire, NP15	Public Open Space	1400 sqm	1400 sqm	?	n/a	n/a	Unsuitable
Cornpoppy Avenue (269.9 sq m) Open Space	Cornpoppy Avenue (269.9 sq m) Open Space, Monmouth, Monmouthshire, NP25 5SD	Public Open Space	269sqm	Too small	n/a	n/a	n/a	Unsuitable
Courtfield Close (117.9 sq m) Open Space	Courtfield Close (117.9 sq m) Open Space, Monmouth, Monmouthshire, NP25 5ED	Public Open Space	117sqm	Too small	n/a	n/a	n/a	Unsuitable
Cowleaze Open space	Cowleaze Open space, Magor, Monmouthshire, NP26 3LE	Public Open Space	450 sqm	Too small	n/a	n/a	n/a	Unsuitable
Croeson Parc Public Open Space	Croeson Parc Public Open Space, Abergavenny, Monmouthshire, NP7 6PF	Public Open Space	1.95 acres	7891 sqm	Small area of zone 3 surface water			Next stage
Croeson Cottages, Land adjacent to	Croeson Cottages, Land adjacent to, Abergavenny, Monmouthshire, NP7 6BJ	Public Open Space	72 sqm	Too small	n/a	n/a	n/a	Unsuitable
De Cantelupe Close Open Space	De Cantelupe Close Open Space, Abergavenny, Monmouthshire, NP7 9JB	Public Open Space	12350 sqm	12350 sqm	?	Largely sloped topography	n/a	Unsuitable
Deans Hill Open Space	Deans Hill Open Space, Chepstow, Monmouthshire, NP16 5AT	Public Open Space	1209 sqm	1209 sqm	n/a	Unclear - appears to be sloped	n/a	Unsuitable
Deepweir Open Space (189.3 sq m)	Deepweir Open Space (189.3 sq m), Caldicot, Monmouthshire, NP26 5JG	Public Open Space	189sqm	Too small	n/a	n/a	n/a	Unsuitable
Deepweir Open Space (27.07) sq m	Deepweir Open Space (27.07) sq m, Caldicot, Monmouthshire, NP26 5JG	Public Open Space	27sqm	Too small	n/a	n/a	n/a	Unsuitable
Deepweir Open Space 137.5 sq m	Deepweir Open Space 137.5 sq m, Caldicot, Monmouthshire, NP26 5JG	Public Open Space	137sqm	Too small	n/a	n/a	n/a	Unsuitable
Deepweir Open Space 184.1sq m	Deepweir Open Space 184.1sq m, Caldicot, Monmouthshire, NP26 5JG	Public Open Space	184sqm	Too small	n/a	n/a	n/a	Unsuitable
Deepweir Open Space 75.32 sq m	Deepweir Open Space 75.32 sq m, Caldicot, Monmouthshire, NP26 5JG	Public Open Space	75sqm	Too small	n/a	n/a	n/a	Unsuitable
Deri View Open Space	Deri View Open Space, Charles Close, Abergavenny, Monmouthshire, NP7 6AX	Public Open Space	4936 sqm	4936 sqm	n/a	Car Park	n/a	Unsuitable
Derwen Way Open Space	Derwen Way Open Space, Abergavenny, Monmouthshire, NP7 6BP	Public Open Space		Too small	n/a	n/a	n/a	Unsuitable
Drybridge Park Open Space	Drybridge Park Open Space, Monmouth, Monmouthshire, NP25 5AS	Public Open Space	6.42 acres	6.42 acres	?	n/a	Skate Park	Unsuitable
Elan Way (26.65 sq m) Open Space	Elan Way (26.65 sq m) Open Space, Caldicot, Monmouthshire, NP26 4PZ	Public Open Space	26sqm	Too small	n/a	n/a	n/a	Unsuitable
Elan Way (303.4 sq m) Open Space	Elan Way (303.4 sq m) Open Space, Caldicot, Monmouthshire, NP26 4PZ	Public Open Space	303sqm	Too small	n/a	n/a	n/a	Unsuitable
Elan Way (334.3 sq m) Open Space	Elan Way (334.3 sq m) Open Space, Caldicot, Monmouthshire, NP26 4PZ	Public Open Space	334sqm	Too small	n/a	n/a	n/a	Unsuitable
Elan Way (45.9 sq m) Open Space	Elan Way (45.9 sq m) Open Space, Caldicot, Monmouthshire, NP26 4PZ	Public Open Space	45sqm	Too small	n/a	n/a	n/a	Unsuitable
Elan Way (6.386 sq m) Open Space	Elan Way (6.386 sq m) Open Space, Caldicot, Monmouthshire, NP26 4PZ	Public Open Space	6.3 sqm	Too small	n/a	n/a	n/a	Unsuitable
Elan Way (81.81 sq m) Open Space	Elan Way (81.81 sq m) Open Space, Caldicot, Monmouthshire, NP26 4PZ	Public Open Space	81sqm	Too small	n/a	n/a	n/a	Unsuitable
Elstob Way (196.5 sq m) Open Space	Elstob Way (196.5 sq m) Open Space, Monmouth, Monmouthshire, NP25 5ET	Public Open Space	196sqm	Too small	n/a	n/a	n/a	Unsuitable

Elstob Way (228.3 sq m) Open Space	Elstob Way (228.3 sq m) Open Space, Monmouth, Monmouthshire, NP25 5ET	Public Open Space	228sqm	Too small	n/a	n/a	n/a	Unsuitable
Elstob Way (285.6 sq m) Open Space	Elstob Way (285.6 sq m) Open Space, Monmouth, Monmouthshire, NP25 5ET	Public Open Space	285sqm	Too small	n/a	n/a	n/a	Unsuitable
Elstob Way (370.2 sq m) Open Space	Elstob Way (370.2 sq m) Open Space, Monmouth, Monmouthshire, NP25 5ET	Public Open Space	370sqm	Too small	n/a	n/a	n/a	Unsuitable
Elstob Way (375.4 sq m) Open Space	Elstob Way (375.4 sq m) Open Space, Monmouth, Monmouthshire, NP25 5ET	Public Open Space	375sqm	Too small	n/a	n/a	n/a	Unsuitable
Elstob Way (58.13 sq m) Open Space	Elstob Way (58.13 sq m) Open Space, Monmouth, Monmouthshire, NP25 5ET	Public Open Space	58sqm	Too small	n/a	n/a	n/a	Unsuitable
Elstob Way (strip) Open Space	Elstob Way (strip) Open Space, Monmouth, Monmouthshire, NP25 5ET	Public Open Space		Too small	n/a	n/a	n/a	Unsuitable
Ethley Drive (5608 sq m) Open Space	Ethley Drive (5608 sq m) Open Space, Raglan, Usk, Monmouthshire, NP26 2FB	Public Open Space	5608 sqm	5608 sqm	Yes	n/a	n/a	Unsuitable
Fitzroy Close Open Space (Clawddu)	Fitzroy Close Open Space (Clawddu), Monmouth, Monmouthshire, NP25 5BJ	Public Open Space	1605 sqm	Irregular shape - Too small	n/a	n/a	n/a	Unsuitable
Forest Hill Open Space	Forest Hill Open Space, Gilwern, Abergavenny, Monmouthshire, NP7 0DY	Public Open Space	560 sqm	560 sqm	n/a	Unfavourable topography	n/a	Unsuitable
Forest View Amenity Land	Forest View Amenity Land, The Narth, Monmouth, Monmouthshire, NP25 4QQ	Public Open Space	270 sqm	Too small	n/a	n/a	n.a	Unsuitable
Former Railway Usk, Land comprising	Former Railway Usk, Land comprising 7 parcels, Usk, Monmouthshire, NP15	Public Open Space	1.82 acres	1.82 aces	?	Unfavourable topography	n/a	Unsuitable
Garthi Close Open Space	Garthi Close Open Space, Mitchel Troy, Monmouth, Monmouthshire, NP25 4JN	Public Open Space	1.56 acres	6318 sqm	No			Next stage
Garvey Close (158.5 sq m) Public Open Space	Garvey Close (158.5 sq m) Public Open Space, Chepstow, Monmouthshire, NP16 5TD	Public Open Space	158sqm	Too small	n/a	n/a	n/a	Unsuitable
Garvey Close (296.5 sq m) Public Open Space	Garvey Close (296.5 sq m) Public Open Space, Chepstow, Monmouthshire, NP16 5TD	Public Open Space	296sqm	Too small	n/a	n/a	n/a	Unsuitable
Geoffrey Drive Open Space	Geoffrey Drive Open Space, Monmouth, Monmouthshire, NP25 5TR	Public Open Space	6027 sqm	6027 sqm	n/a	n/a	Childrens Play Area	Unsuitable
Gethin Place Amenity Land	Gethin Place Amenity Land, Llanfair Kilgeddin, Abergavenny, Monmouthshire, NP7 9EA	Public Open Space	423 sqm	Too small	n.a	n/a	n/a	Unsuitable
Glan Gavenny Open Space	Glan Gavenny Open Space, Abergavenny, Monmouthshire, NP7 6NQ	Public Open Space	4024 sqm	Irregular shape - Too small	Yes	n/a	n/a	Unsuitable
Goldwire Lane Amenity Land	Goldwire Lane Amenity Land, Monmouth, Monmouthshire, NP25 5AL	Public Open Space	277 sqm	Too small	n.a	n/a	n/a	Unsuitable
Goldwire Lane Open Space	Goldwire Lane Open Space, Monmouth, Monmouthshire, NP25 5AQ	Public Open Space	0.37 acres	1509 sqm	Defended Zone 3 Rivers			Unsuitable - Flood Risk
Granville Street, Land at	Granville Street, Land at, Monmouth, Monmouthshire, NP25 3DR	Public Open Space	0.15 acres	630 sqm	Zone 2 Rivers			Unsuitable - Flood risk
Grosmont Close (4691 sq m) Open Space	Grosmont Close (4691 sq m) Open Space, Monmouth, Monmouthshire, NP25 5UF	Public Open Space	1.15 acres	4691 sqm	Defended Zone 3 Rivers			Unsuitable - Flood Risk
Hadnock Road & River Wye, Land between	Hadnock Road & River Wye, Land between, Monmouth, Monmouthshire, NP25	Public Open Space	5400 sqm	Irregular shape - Too small	n/a	n/a	n/a	Unsuitable
Hastings Close Open Space	Hastings Close Open Space, Abergavenny, Monmouthshire, NP7 9JD	Public Open Space	1.28 acres	1.28 acres	n/a	n/a	Playing Fields	Unsuitable
Hawthorn Close (264.3 sq m) Open Space	Hawthorn Close (264.3 sq m) Open Space, Chepstow, Monmouthshire, NP16 5RG	Public Open Space	264sqm	Too small	n/a	n/a	n/a	Unsuitable
Heol Sirhowy Open Space	Heol Sirhowy Open Space, Heol Sirhowy, Caldicot	Public Open Space	4900 sqm	4900 sqm	n/a	n/a	Childrens Play Area / Playing Field	Unsuitable
High Beech Lane Open Space	High Beech Lane Open Space, Chepstow, Monmouthshire, NP16 5BQ	Public Open Space	0.27 acres	1095 sqm	No			Next stage
Highfield Amenity Land	Highfield Amenity Land, Goytre, Abergavenny, Monmouthshire, NP4 0AQ	Public Open Space	426 sqm	Too small	n/a	n/a	n/a	Unsuitable
Highfield Communal Area	Highfield Communal Area, Goetre, Abergavenny, Monmouthshire, NP4 0BH	Public Open Space	467 sqm	Too small	n/a	n/a	n/a	Unsuitable
Highmeadow Open Space	Highmeadow Open Space, Wyesham, Monmouth, Monmouthshire, NP25 3TB	Public Open Space	107 sqm	Too small	n/a	n/a	n/a	Unsuitable
Hill Barn View Open Space	Hill Barn View Open Space, Portskewett, Caldicot, Monmouthshire, NP26 5SE	Public Open Space	0.32 acres	1294 sqm	No			Next stage
Holly Close (126.5 sq m) Open Space	Holly Close (126.5 sq m) Open Space, Chepstow, Monmouthshire, NP16 5RP	Public Open Space	126sqm	Too small	n/a	n/a	n/a	Unsuitable
Holly Close (28.16 sq m) Open Space	Holly Close (28.16 sq m) Open Space, Chepstow, Monmouthshire, NP16 5RP	Public Open Space	28sqm	Too small	n/a	n/a	n/a	Unsuitable
Holly Close (34.86 sq m) Open Space	Holly Close (34.86 sq m) Open Space, Chepstow, Monmouthshire, NP16 5RP	Public Open Space	34sqm	Too small	n/a	n/a	n/a	Unsuitable
Holly Close (445.8 sq m) Open Space	Holly Close (445.8 sq m) Open Space, Chepstow, Monmouthshire, NP16 5RP	Public Open Space	445sqm	Too small	n/a	n/a	n/a	Unsuitable
Holywell Close (376.2 sq m) Open Space	Holywell Close (376.2 sq m) Open Space, Monmouth, Monmouthshire, NP25 5EU	Public Open Space	376sqm	Too small	n/a	n/a	n/a	Unsuitable



Holywell Close (423.5 sq m) Open Space	Holywell Close (423.5 sq m) Open Space, Monmouth, Monmouthshire, NP25 5EU	Public Open Space	423sqm	Too small	n/a	n/a	n/a	Unsuitable
Holywell Crescent Open Space	Holywell Crescent Open Space, Abergavenny, Monmouthshire, NP7 5LG	Public Open Space	0.22 acres	919 sqm	No			Next stage
Kemeys Road Amenity Land & Sewerage Works	Kemeys Road Amenity Land & Sewerage Works, Llanccayo, Usk, Monmouthshire, NP15 1JA	Public Open Space	0.85 acres	3462 sqm	Zone 23 Rivers & Zone 3 Surface Water			Unsuitable - Flood risk
Kemys Craig Wood, Land at	Kemys Craig Wood, Land at, Llantrisant, Usk, Monmouthshire	Public Open Space		?	n.a	Woodland	na	Unsuitable
Kings Fee Open Space	Kings Fee Open Space, Monmouth, Monmouthshire, NP25 5BW	Public Open Space		3652 sqm	n/a	n/a	Childrens Play Area	Unsuitable
Laburnam Way (113.1 sq m) Open Space	Laburnam Way (113.1 sq m) Open Space, Chepstow, Monmouthshire, NP16 5RF	Public Open Space	113sqm	Too small	n/a	n/a	n/a	Unsuitable
Laburnam Way (521.6 sq m) Open Space	Laburnam Way (521.6 sq m) Open Space, Chepstow, Monmouthshire, NP16 5RF	Public Open Space	521sqm	Irregular shape - Too small	n/a	n/a	n/a	Unsuitable
Landau Close (136.8) Open Space	Landau Close (136.8) Open Space, Undy, Magor, Monmouthshire, NP26 3NT	Public Open Space	136sqm	Too small	n/a	n/a	n/a	Unsuitable
Landau Close (351.7) Open Space	Landau Close (351.7) Open Space, Undy, Magor, Monmouthshire, NP26 3NT	Public Open Space	351sqm	Too small	n/a	n/a	n/a	Unsuitable
Lapwing Avenue Open Space	Lapwing Avenue Open Space, Undy, Magor, Monmouthshire, NP26 5RN	Public Open Space	614 sqm	614 sqm	Irregular shape - too small	n/a	n/a	Unsuitable
Laurel Close Open Space	Laurel Close Open Space, Undy, Magor, Monmouthshire, NP26 3NP	Public Open Space	100 sqm	Too small	n.a	n.a	n.a	Unsuitable
Laurel Close Open Space	Laurel Close Open Space, Undy, Magor, Monmouthshire, NP26 3NP	Public Open Space	112 sqm	Too small	n/a	n.a	n/a	Unsuitable
Limetree Avenue Amenity Land	Limetree Avenue Amenity Land, Wyesham, Monmouth, Monmouthshire, NP25 3LA	Public Open Space	356 sqm	Too small	n/a	n/a	n/a	Unsuitable
Llanellen Road Amenity Land	Llanellen Road Amenity Land, Llanfoist, Abergavenny, Monmouthshire, NP7 9LY	Public Open Space	0.42 acres	1711 sqm	No			Next stage
Llanvair Road Open Space	Llanvair Road Open Space, Caerwent, Caldicot, Monmouthshire, NP26 5NY	Public Open Space	0.33 acres	1356 sqm	No			Next stage
LLwyn Melin Open Space	LLwyn Melin Open Space, Clydach, Abergavenny, Monmouthshire, NP7 0LJ	Public Open Space	Too small	Too small	n/a	n/a	n/a	Unsuitable
Maesy Llawydd ( 1086sqm) Open Space	Maesy Llawydd ( 1086sqm) Open Space, Abergavenny, Monmouthshire, NP7 5LQ	Public Open Space		1086 sqm	n.a	Unfavourable topography	n/a	Unsuitable
Maesy Llawydd ( 653.4sqm) Open Space	Maesy Llawydd ( 653.4sqm) Open Space, Abergavenny, Monmouthshire, NP7 5LQ	Public Open Space	653 sqm	653 sqm	n/a	n/a	Childrens Play Area	Unsuitable
Main Road (264.9 sq m) Open Space	Main Road (264.9 sq m) Open Space, Magor, Caldicot, Monmouthshire, NP26 3HN	Public Open Space	264sqm	Too small	n/a	n/a	n/a	Unsuitable
Manor Wood Open Space (259.6 sqm)	Manor Wood Open Space (259.6 sqm), Bayfield, Chepstow, Monmouthshire, NP16 6DS	Public Open Space	259sqm	Too small	n/a	n/a	n/a	Unsuitable
Manson Heights Amenity Land	Manson Heights Amenity Land, Monmouth, Monmouthshire, NP25 5QX	Public Open Space	0.19 acres	775 sqm	No			Next stage
Maple Avenue (109.3 sq m) Open Space	Maple Avenue (109.3 sq m) Open Space, Chepstow, Monmouthshire, NP16 5RG	Public Open Space	109sqm	too small	n/a	n/a	n/a	Unsuitable
Maple Avenue (120.1 sq m) Open Space	Maple Avenue (120.1 sq m) Open Space, Chepstow, Monmouthshire, NP16 5RG	Public Open Space	120sqm	too small	n/a	n/a	n/a	Unsuitable
Maple Avenue (171.6 sq m) Open Space	Maple Avenue (171.6 sq m) Open Space, Chepstow, Monmouthshire, NP16 5RG	Public Open Space	171 sqm	too small	na	na	na	Unsuitable
Maple Avenue (56.64 sq m) Open Space	Maple Avenue (56.64 sq m) Open Space, Chepstow, Monmouthshire, NP16 5RG	Public Open Space	56sqm	too small	n/a	n/a	n/a	Unsuitable
Maple Avenue (674.1 sq m) Open Space	Maple Avenue (674.1 sq m) Open Space, Chepstow, Monmouthshire, NP16 5RG	Public Open Space	674 sqm	674 sqm	n/a	n/a	Playing Fields	Unsuitable
Martin Close Open Space	Martin Close Open Space, Rogiet, Caldicot, Monmouthshire, NP26 3UG	Public Open Space	715 sqm	715 sqm	n/a	n/a	Childrens Play Area	Unsuitable
Mary De Bohun Close ( 708.6 sq m) Open Space	Mary De Bohun Close ( 708.6 sq m) Open Space, Monmouth, Monmouthshire, NP25 5UB	Public Open Space	0.17 acres	708 sqm	Defended Zone 2 Rivers			Unsuitable - Flood Risk
Mayfield Lodge, Land adjacent	Mayfield Lodge, Land adjacent, Usk, Monmouthshire, NP15	Public Open Space	1.95 acres	1.95 acres	Yes	n/a	n/a	Unsuitable
Meadow Rise (115.1 sq m) Open Space	Meadow Rise (115.1 sq m) Open Space, Undy, Magor, Monmouthshire, NP26 3JW	Public Open Space	115sqm	Too small	N/a	N/a	N/a	Unsuitable
Meadow Rise (132.1 sq m) Open Space	Meadow Rise (132.1 sq m) Open Space, Undy, Magor, Monmouthshire, NP26 3JW	Public Open Space	132sqm	Too small	N/a	N/a	N/a	Unsuitable
Merlin Close Open Space	Merlin Close Open Space, Monmouth, Monmouthshire, NP26 3UX	Public Open Space	368 sqm	Irregular shape - Too small	n/a	n/a	n/a	Unsuitable
Mill Common Open Space	Mill Common Open Space, Magor, Caldicot, Monmouthshire, NP26 3JH	Public Open Space	7.6 acres	7.6 acres	?	Planting/Woodland	n/a	Unsuitable
Mill Reen ( 564 sq m) Open Space	Mill Reen ( 564 sq m) Open Space, Magor, Caldicot, Monmouthshire, NP26 3JP	Public Open Space	564 sqm	564 sqm	Yes	n/a	n/a	Unsuitable
Mill Reen (425.6 sq m) Open Space	Mill Reen (425.6 sq m) Open Space, Magor, Caldicot, Monmouthshire, NP26 3JP	Public Open Space	425sqm	Too small	N/a	N/a	N/a	Unsuitable

Millfield Park Open Space	Millfield Park Open Space, Magor, Caldicot, Monmouthshire, NP26 3LF	Public Open Space		Too small	n/a	n/a	n/a	Unsuitable
Mount Pleasant Open Space	Mount Pleasant Open Space, Main Road, Clydach, Abergavenny, Monmouthshire, NP7 0LL	Public Open Space	287 sqm	Too small	n/a	n/a	n/a	Unsuitable
Mounton Close Open Space	Mounton Close Open Space, Chepstow, Monmouthshire, NP16 5EG	Public Open Space	0.21 acres	881 sqm	No			Next stage
Mounton Drive Open Space	Mounton Drive Open Space, Chepstow, Monmouthshire, NP16 5EH	Public Open Space	1961 sqm	1961 sqm	n/a	n/a	Playing Fields	Unsuitable
Nedderm Court Open Space(East)	Nedderm Court Open Space(East), Nedderm Way, Caldicot, Monmouthshire, NP26 4GX	Public Open Space	2013 sqm	2013 sqm	n/a	n/a	Playing Fields / Playground	Unsuitable
Nedderm Court Open Space(West)	Nedderm Court Open Space(West), Nedderm Way, Caldicot, Monmouthshire, NP26 4GX	Public Open Space	4611 sqm	4611 sqm	n/a	n/a	Playing Fields / Playground	Unsuitable
North East of Pwll Bach (off A449), Land	North East of Pwll Bach (off A449), Land, Llantrisant, Usk, Monmouthshire	Public Open Space		Too small	n/a	Woodland	n/a	Unsuitable
North of Newbridge on Usk Picnic site	North of Newbridge on Usk Picnic site (off A449), Land, Llantrisant, Usk, Monmouthshire	Public Open Space		Too small	n/a	Woodland	n/a	Unsuitable
Oak Close Open Space	Oak Close Open Space, Undy, Magor, Monmouthshire, NP26 3LR	Public Open Space		Too small	n/a	n/a	n/a	Unsuitable
Oak Grove Open Space	Oak Grove Open Space, Rockfield, Monmouth, Monmouthshire, NP25 5PY	Public Open Space	0.74 acres	3003 sqm	No			Next stage
Oaklands Drive (11030 sq m) Open Space	Oaklands Drive (11030 sq m) Open Space, Monmouth, Monmouthshire, NP25 5DT	Public Open Space		2.38 acres	Yes	n/a	n/a	Unsuitable
Oaklands Drive (274.1sqm) Public Open Space	Oaklands Drive (274.1sqm) Public Open Space, Monmouth, Monmouthshire, NP25 5DT	Public Open Space	274sqm	Too small	N/a	N/a	N/a	Unsuitable
Oakley Way, Land at rear	Oakley Way, Land at rear, Caldicot, Monmouthshire, NP26 4EA	Public Open Space	813 sqm	Irregular shape - Too small	n/a	n/a	n/a	Unsuitable
Orchard Close Amenity Land	Orchard Close Amenity Land, Skenfrith, Abergavenny, Monmouthshire, NP7 8UG	Public Open Space	256 sqm	Too small	n/a	n/a	n.a	Unsuitable
Osprey Drive Open Space	Osprey Drive Open Space, Undy, Magor, Monmouthshire, NP26 5RL	Public Open Space	295 sqm	Too small	n/a	n/a	n/a	Unsuitable
Park Crescent & Hereford Road Open Space	Park Crescent & Hereford Road Open Space, Abergavenny, Lansdown, NP7 5TN	Public Open Space	476 sqm	Too small	n/a	n/a	n/a	Unsuitable
Park Crescent Open Space	Park Crescent Open Space, Abergavenny, Monmouthshire, NP7 5TN	Public Open Space	289 sqm	Too small	n/a	n/a	n/a	Unsuitable
Pembroke Court Open space	Pembroke Court Open space, Undy, Caldicot, Monmouthshire, NP26 3QD	Public Open Space	139 sqm	Too small	n/a	n/a	n/a	Unsuitable
Pennyfarthing Lane Open Space	Pennyfarthing Lane Open Space, Undy, Magor, Monmouthshire, NP26 3NU	Public Open Space	3.3 acres	3.3 acres	n/a	Vegetation/woodland	n/a	Unsuitable
Penterry Park (15940 sq m) Open Space	Penterry Park (15940 sq m) Open Space, Chepstow, Monmouthshire, NP16 5AZ	Public Open Space	15940 sqm	15940 sqm	n/a	Unfavourable topography	n.a	Unsuitable
Penterry Park (383 sq m) Open Space	Penterry Park (383 sq m) Open Space, Chepstow, Monmouthshire, NP16 5AZ	Public Open Space	383sqm	Too small	N/a	N/a	N/a	Unsuitable
Phoenix Drive (329.3 sq m) Open Space	Phoenix Drive (329.3 sq m) Open Space, Chepstow, Monmouthshire, NP16 5TJ	Public Open Space	329sqm	Too small	N/a	N/a	N/a	Unsuitable
Plover Crescent Open Space	Plover Crescent Open Space, Undy, Magor, Monmouthshire, NP26 5ET	Public Open Space	0.24 acres	995 sqm	No			Next stage
Poorscript Lane Amenity Land	Poorscript Lane Amenity Land, Grosmont, Abergavenny, Monmouthshire, NP7 8LP	Public Open Space	0.13 acres	528 sqm	No			Next stage
Poplar Close (376.7 sq m) Open Space	Poplar Close (376.7 sq m) Open Space, Rogiet, Caldicot, Monmouthshire, NP26 3TL	Public Open Space	376sqm	Too small	n/a	n/a	n/a	Unsuitable
Poplar Close (91.75 sq m) Open Space	Poplar Close (91.75 sq m) Open Space, Rogiet, Caldicot, Monmouthshire, NP26 3TL	Public Open Space	91sqm	Too small	n/a	n/a	n/a	Unsuitable
Port Mahon Close (111.4 sq m) Open Space	Port Mahon Close (111.4 sq m) Open Space, Monmouth, Monmouthshire, NP25 5DX	Public Open Space	111sqm	Too small	n/a	n/a	n/a	Unsuitable
Port Mahon Close (57.99 sq m) Open Space	Port Mahon Close (57.99 sq m) Open Space, Monmouth, Monmouthshire, NP25 5DX	Public Open Space	57sqm	Too small	n/a	n/a	n/a	Unsuitable
Port Mahon Close (88.51 sq m) Open Space	Port Mahon Close (88.51 sq m) Open Space, Monmouth, Monmouthshire, NP25 5DX	Public Open Space	88sqm	Too small	n/a	n/a	n/a	Unsuitable
Prince Charles Road (299.2 sq m) Open Space	Prince Charles Road (299.2 sq m) Open Space, Raglan, Usk, Monmouthshire, NP15 2FB	Public Open Space	299sqm	Too small	n/a	n/a	n/a	Unsuitable
Prince Charles Road Open Space	Prince Charles Road Open Space, Raglan, Monmouthshire, NP15 2FB	Public Open Space	3894 sqm	3894 sqm	n/a	n/a	Childrens Play Area	Unsuitable
Quarry Rise Open Space	Quarry Rise Open Space, Undy, Magor, Monmouthshire, NP25 3JU	Public Open Space	1324 sqm	1324 sqm	n/a	Unfavourable topography	n/a	Unsuitable
Reade Street Open Space	Reade Street Open Space, Wyesham, Monmouth, Monmouthshire, NP25 3TJ	Public Open Space	1328 sqm	1328 sqm	n/a	Unfavourable topography	n/a	Unsuitable
Redbrook Road Amenity Land	Redbrook Road Amenity Land, Wyesham, Monmouth, Monmouthshire	Public Open Space	1351 sqm	1351 sqm	n/a	Unfavourable topography	n/a	Unsuitable
Rhyd y Meirch Open Space	Rhyd y Meirch Open Space, Llanover, Abergavenny, Monmouthshire, NP7 9EU	Public Open Space	0.44 acres	1810 sqm	No			Next stage

River View (289.7 sq m) Open Space	River View (289.7 sq m) Open Space, Chepstow, Monmouthshire, NP16 5AX	Public Open Space	289sqm	Too small	n/a	n/a	n/a	Unsuitable
River View (331.5 sq m) Open Space	River View (331.5 sq m) Open Space, Chepstow, Monmouthshire, NP16 5AX	Public Open Space	331sqm	Too small	n/a	n/a	n/a	Unsuitable
River View (560.9 sq m) Open Space	River View (560.9 sq m) Open Space, Chepstow, Monmouthshire, NP16 5AX	Public Open Space	560 sqm	Irregular shape - Too small	n/a	n/a	n.a	Unsuitable
Rockfield Grove (1022 sq m) Open Space	Rockfield Grove (1022 sq m) Open Space, Undy, Caldicot, Monmouthshire, NP26 3FB	Public Open Space	0.25 acres	1022 sqm	Flood Zone 3 Sea and Zone 2 Sea covering access to site			Unsuitable - Flood risk
Rockfield Grove (483.6 sq m) Open Space	Rockfield Grove (483.6 sq m) Open Space, Undy, Caldicot, Monmouthshire, NP26 3FB	Public Open Space		Too small	n/a	n/a	n/a	Unsuitable
Rockfield View Open Space	Rockfield View Open Space, Undy, Magor, Monmouthshire, NP26 3FD	Public Open Space	1177sqm	1177 sqm	n/a	n/a	Childrens Play Area	Unsuitable
Rockfield Way Open Space	Rockfield Way Open Space, Undy, Magor, Monmouthshire, NP26 3FD	Public Open Space	2139 sqm	Irregular shape - Too small	n.a	n/a	n/a	Unsuitable
Rocklea Open Space	Rocklea Open Space, Mitchell Troy, Monmouth, Monmouthshire, NP25 4JE	Public Open Space	0.74 acres	3035 sqm	Surface Water Zone 2 & 3 around the edge of the site.			Next stage
Rogiet Primary, Land adjacent (14384 sq m)	Rogiet Primary, Land adjacent, Station Road, Rogiet, Monmouthshire, NP26 3SD	Public Open Space	14384 sqm	14384 sqm	n/a	School grounds	n/a	Unsuitable
Rolls Avenue Open Space	Rolls Avenue Open Space, Monmouth, Monmouthshire, NP25 5AY	Public Open Space	354 sqm	too small	n/a	n/a	n/a	Unsuitable
Ross Road (9085 sq m) Open Space	Ross Road (9085 sq m) Open Space, Abergavenny, Monmouthshire, NP7 5LT	Public Open Space	2.24 acres	2.24 acres	Yes	Unfavourable topography	n.a	Unsuitable
Rowan Drive (111.3 sq m) Open Space	Rowan Drive (111.3 sq m) Open Space, Chepstow, Monmouthshire, NP16 5RQ	Public Open Space	111sqm	Too small	n/a	n/a	n/a	Unsuitable
Rowan Drive (132.8 sq m) Open Space	Rowan Drive (132.8 sq m) Open Space, Chepstow, Monmouthshire, NP16 5RQ	Public Open Space	132sqm	Too small	n/a	n/a	n/a	Unsuitable
Rowan Drive (153.3 sq m) Open Space	Rowan Drive (153.3 sq m) Open Space, Chepstow, Monmouthshire, NP16 5RQ	Public Open Space	153sqm	Too small	n/a	n/a	n/a	Unsuitable
Rowan Drive (26.91 sq m) Open Space	Rowan Drive (26.91 sq m) Open Space, Chepstow, Monmouthshire, NP16 5RQ	Public Open Space	26sqm	Too small	n/a	n/a	n/a	Unsuitable
Rowan Drive (46.6 sq m) Open Space	Rowan Drive (46.6 sq m) Open Space, Chepstow, Monmouthshire, NP16 5RQ	Public Open Space	46sqm	Too small	n/a	n/a	n/a	Unsuitable
Rowan Drive (911.3 sq m) Open Space	Rowan Drive (911.3 sq m) Open Space, Chepstow, Monmouthshire, NP16 5RQ	Public Open Space	0.22 acres	911 sqm	No			Next Stage
Rowing Club, Land adjacent	Rowing Club, Land adjacent, Monmouth, Monmouthshire, NP25 3DP	Public Open Space	4634 sqm	4634 sqm	Yes	n/a	n/a	Unsuitable
Rushey Meadow Open Space (7518sqm)	Rushey Meadow Open Space (7518sqm), Monmouth, Monmouthshire, NP25 5BT	Public Open Space	7518 sqm	Irregular shape - Too small	n/a	n/a	n/a	Unsuitable
Samuel Salter Close (342.3 sq m) Open Space	Samuel Salter Close (342.3 sq m) Open Space, Llanfoist, Abergavenny, Monmouthshire, NP7 9NZ	Public Open Space	342sqm	Too small	n/a	n/a	n/a	Unsuitable
Sarno Square (170705 sq m) Open Space	Sarno Square (170705 sq m) Open Space, Abergavenny, Monmouthshire, NP7 5JT	Public Open Space	42 acres	16,9967 sqm	No			Next stage
School Hill (153.6 sq m) Open Space	School Hill (153.6 sq m) Open Space, Chepstow, Monmouthshire, NP16 5BZ	Public Open Space	153sqm	Too small	n/a	n/a	n/a	Unsuitable
School Hill (30.10 sq m) Open Space	School Hill (30.10 sq m) Open Space, Chepstow, Monmouthshire, NP16 5BZ	Public Open Space	30sqm	Too small	n/a	n/a	n/a	Unsuitable
School Hill (368.3 sq m) Open Space	School Hill (368.3 sq m) Open Space, Chepstow, Monmouthshire, NP16 5BZ	Public Open Space	368sqm	Too small	n/a	n/a	n/a	Unsuitable
School Hill (399.5 sq m) Open Space	School Hill (399.5 sq m) Open Space, Chepstow, Monmouthshire, NP16 5BZ	Public Open Space	399 sqm	Too small	n/a	n/a	n/a	Unsuitable
School Hill (40.98 sq m) Open Space	School Hill (40.98 sq m) Open Space, Chepstow, Monmouthshire, NP16 5BZ	Public Open Space	40sqm	Too small	n/a	n/a	n/a	Unsuitable
School Hill (8.743 sq m) Open Space	School Hill (8.743 sq m) Open Space, Chepstow, Monmouthshire, NP16 5BZ	Public Open Space	8sqm	Too small	n/a	n/a	n/a	Unsuitable
Shakespeare Drive Open Space	Shakespeare Drive Open Space, Caldicot, Monmouthshire, NP26 4LW	Public Open Space	366 sqm	Too small	n/a	n/a	n/a	Unsuitable
Somerset Road Open Space	Somerset Road Open Space, Monmouth, Monmouthshire, NP25 5AJ	Public Open Space	206 sqm	Too small	n/a	n/a	n/a	Unsuitable
Somerset Way Open Space	Somerset Way Open Space, Chepstow, Monmouthshire, NP16 5NP	Public Open Space	300 sqm	Too small	n/a	n.a	n.a	Unsuitable
St Andrews Crescent Amenity Land (180.8 sqm)	St Andrews Crescent Amenity Land (180.8 sqm), Abergavenny, Monmouthshire, NP7 6HN	Public Open Space	180sqm	Too small	n/a	n/a	n/a	Unsuitable
St Andrews Crescent Amenity Land (2833sqm)	St Andrews Crescent Amenity Land (2833sqm), Abergavenny, Monmouthshire, NP7 6HN	Public Open Space	2833 sqm	Irregular shape - Too small	n/a	n.a	n/a	Unsuitable
St Andrews Crescent, Highways verge	St Andrews Crescent, Highways verge at, Abergavenny, Monmouthshire, NP7 6HN	Public Open Space	500 sqm	Irregular shape - Too small	n/a	n/a	n/a	Unsuitable
St Davids Crescent amenity land	St Davids Crescent amenity land, Llandewi Rhydderch, Abergavenny, Monmouthshire, NP7 9TR	Public Open Space	1531 sqm	1531 sqm	n/a	n/a	Childrens Play Area	Unsuitable

St Davids Road Amenity Land	St Davids Road Amenity Land, Abergavenny, Monmouthshire, NP7 6HD	Public Open Space	40 sqm	Too small	n.a	n/a	n/a	Unsuitable
St Davids Road Open Space	St Davids Road Open Space, Abergavenny, Monmouthshire, NP7 6HD	Public Open Space	42 sqm	Too small	n/a	n/a	n/a	Unsuitable
St Dials Wood Open Space	St Dials Wood Open Space, Castle Close, Monmouth, Monmouthshire, NP25 5UG	Public Open Space	5301 sqm	1.31 acres	Defended Zone 3 River & Zone 2& 3 surface water			Unsuitable - Flood Risk
St Dubricius Gardens (869.2 sq m) Open Space	St Dubricius Gardens (869.2 sq m) Open Space, Undy, Caldicot, Monmouthshire, NP26 3PN	Public Open Space	0.21 acres	869 sqm	No			Next stage
St Faiths Close (319.5 sq m) Open Space	St Faiths Close (319.5 sq m) Open Space, Llanfoist, Abergavenny, Monmouthshire, NP7 9NJ	Public Open Space	319sqm	Too small	n/a	n/a	n/a	Unsuitable
St Faiths Close (512.9 sq m) Open Space	St Faiths Close (512.9 sq m) Open Space, Llanfoist, Abergavenny, Monmouthshire, NP7 9NJ	Public Open Space	512 sqm	512 sqm	n/a	n/a	Childrens Play Area	Unsuitable
St Helens Road Open Space	St Helens Road Open Space, Abergavenny, Monmouthshire, NP7 5UU	Public Open Space	0.28 acres	1139 sqm	Surface Water Zone 2 & 3			Next stage
St Lawrence Park (262 sq m) Open Space	St Lawrence Park (262 sq m) Open Space, Chepstow, Monmouthshire, NP16 6DP	Public Open Space	262sqm	Too small	n/a	n/a	n/a	Unsuitable
St Lawrence Park (297.2 sq m) Open Space	St Lawrence Park (297.2 sq m) Open Space, Chepstow, Monmouthshire, NP16 6DP	Public Open Space	297sqm	Too small	n/a	n/a	n/a	Unsuitable
St Lawrence Park (644.1 sq m) Open Space	St Lawrence Park (644.1 sq m) Open Space, Chepstow, Monmouthshire, NP16 6DP	Public Open Space		Irregular shape - Too small	n/a	n/a	n/a	Unsuitable
St Stephens Place (166.5 sq m) Open Space	St Stephens Place (166.5 sq m) Open Space, Undy, Caldicot, Monmouthshire, NP26 3PR	Public Open Space	166sqm	Too small	n/a	n/a	n/a	Unsuitable
Starling Close Open Space	Starling Close Open Space, Rogiet, Caldicot, Monmouthshire, NP26 3UU	Public Open Space	4.07 acres	16505 sqm	Zone 3 Sea & small section of Zone 2 & 3 Surface Water			Unsuitable - Flood risk
Station Road Open Space	Station Road Open Space, Portskewett, Caldicot, Monmouthshire, NP26 5SF	Public Open Space	430 sqm	Too small	n/a	n/a	n/a	Unsuitable
Station Road, Land adjacent	Station Road, Land adjacent, Station Road, Rogiet, Caldicot, Monmouthshire, NP26 3UF	Public Open Space		Too small	n/a	n/a	n/a	Unsuitable
Stephens Crescent Amenity Land	Stephens Crescent Amenity Land, Govilon, Abergavenny, Monmouthshire, NP7 9RL	Public Open Space	4696 sqm	4696 sqm	n/a	n/a	Childrens Play Area	Unsuitable
Summerhouse Lane Open Space	Summerhouse Lane Open Space, Chepstow, Monmouthshire, NP16 5SP	Public Open Space	858 sqm	858 sqm	n/a	n/a	Childrens Play Area	Unsuitable
Sycamore Avenue (1546 sq m) Open Space	Sycamore Avenue (1546 sq m) Open Space, Abergavenny, Monmouthshire, NP7 5JY	Public Open Space	0.38 acres	n/a	n/a	Woodland	n/a	Unsuitable
Sycamore Avenue (3210 sq m) Open Space	Sycamore Avenue (3210 sq m) Open Space, Abergavenny, Monmouthshire, NP7 5JY	Public Open Space	0.79 acres	0.79 acres	n/a	Woodland	n/a	Unsuitable
The Island	The Island, Wyebridge, Monmouth, Monmouthshire, NP25 3LS	Public Open Space		Too small	Yes	n/a	n/a	Unsuitable
The Limes Open Space	The Limes Open Space, Undy, Magor, Monmouthshire, NP26 3LU	Public Open Space	36 sqm	Too small	n/a	n/a	n/a	Unsuitable
The Mount, Land at	The Mount, Land at, Off Mount Way, Chepstow, Monmouthshire, NP16 5NF	Public Open Space	7232 sqm	7232 sqm	n/a	Unfavourable topography	n/a	Unsuitable
The Plantation (7314sqm) Open Space	The Plantation (7314sqm) Open Space, Magor, Caldicot, Monmouthshire, NP26 3HR	Public Open Space	1.80 acres	1.80 acres	n/a	Woodland	n.a	Unsuitable
Tree Tops, Land adjacent	Tree Tops, Land adjacent, Vinegar Hill, Undy, Magor, Monmouthshire, NP26 3EJ	Public Open Space	282 sqm	Too small	n.a	n.a	n/a	Unsuitable
Trehonddu Open Space (East)	Trehonddu Open Space (East), Llanvihangel Crucorney, Abergavenny, Monmouthshire, NP7 8DG	Public Open Space	270 sqm	Too small	n/a	n.a	n.a	Unsuitable
Trehonddu Open Space (West)	Trehonddu Open Space (West), Llanvihangel Crucorney, Abergavenny, Monmouthshire, NP7 8DG	Public Open Space	120 sqm	Too small	n/a	n.a	n/a	Unsuitable
Troy Gardens Open Space	Troy Gardens Open Space, Monmouth, Monmouthshire, NP25 5DB	Public Open Space	0.16 acres	655 sqm	No			Next stage
Tudor Road Amenity Land (212.8 sq m)	Tudor Road Amenity Land (212.8 sq m), Wyesham, Monmouth, Monmouthshire, NP25 3LF	Public Open Space	212sqm	Too small	n/a	n/a	n/a	Unsuitable
Tudor Road Amenity Land (327.5 sq m)	Tudor Road Amenity Land (327.5 sq m), Wyesham, Monmouth, Monmouthshire, NP25 3LF	Public Open Space	327sqm	Too small	n/a	n/a	n/a	Unsuitable
Tudor Road Amenity Land (90.35 sq m)	Tudor Road Amenity Land (90.35 sq m), Wyesham, Monmouth, Monmouthshire, NP25 3LF	Public Open Space	90sqm	too small	n/a	n/a	n/a	Unsuitable
Tudor Road Road Open Space	Tudor Road Road Open Space, Wyesham, Monmouth, Monmouthshire, NP25 3LF	Public Open Space	304 sqm	too small	n/a	n/a	n/a	Unsuitable
Usk View Amenity Land	Usk View Amenity Land, Govilon, Abergavenny, Monmouthshire, NP7 9PD	Public Open Space	400 sqm	Too Small	n/a	n.a	n/a	Unsuitable
Vauxhall Fields Recreation Area	Vauxhall Fields Recreation Area, Forge Road, Monmouth, Monmouthshire, NP25 3AX	Public Open Space	21.4 acres	21.4 acres	Yes	n/a	Playing Fields	Unsuitable
Victoria Way Open Space	Victoria Way Open Space, Undy, Magor, Monmouthshire, NP26 3NW	Public Open Space		Irregular shape - Too small	n/a	n/a	n/a	Unsuitable
Warren Slade (Part) Open Space	Warren Slade (Part) Open Space, Adj Denbigh Drive, Chepstow, Monmouthshire, NP16 5SU	Public Open Space		30491 sqm	n/a	Woodland	n/a	Unsuitable
Warren Slade Open Space	Warren Slade Open Space, Bulwark, Chepstow, Monmouthshire, NP16 5NX	Public Open Space		34291 sqm	n/a	Woodland	n/a	Unsuitable

Waterside Open Space	Waterside Open Space, Abergavenny, Monmouthshire, NP7 5LJ	Public Open Space	342 sqm	Too small	n/a	n/a	n/a	Unsuitable
Wentwood View Caldicot Open Space	Wentwood View Caldicot Open Space, Caldicot, Monmouthshire, NP7 9DE	Public Open Space	10848 sqm	10848 sqm	n/a	n/a	n/a	RLDP CANDIDATE SITE
Westfield Open Space	Westfield Open Space, Caldicot, Monmouthshire, NP26 4HE	Public Open Space	177 sqm	too small	n/a	n/a	n/a	Unsuitable
Whitechapel Walk Open Space	Whitechapel Walk Open Space, Undy, Magor, Monmouthshire, NP26 3NS	Public Open Space		Too small	n/a	n/a	n/a	Unsuitable
Willow Drive (404.6sqm) Public Open	Willow Drive (404.6sqm) Public Open Space, Monmouth, Monmouthshire, NP25 5DW	Public Open Space	404sqm	too small	n/a	n/a	n/a	Unsuitable
Willow Drive (4708 sq m) Open Space	Willow Drive (4708 sq m) Open Space, Monmouth, Monmouthshire, NP25 5DW	Public Open Space	4708 sqm	4708 sqm	Yes	na	n/a	Unsuitable
Woodland Crescent Open Space	Woodland Crescent Open Space, Woodland Crescent, Llanfoist, Abergavenny, Monmouthshire, NP7 9JZ	Public Open Space	0.23 acres	933 sqm	Flood Zone 2 Surface Water on small section of southern edge of site. Boundary could exclude it			Next Stage
Woolpitch Wood Open Space (520.2 sqm)	Woolpitch Wood Open Space (520.2 sqm), Bayfield, Chepstow, Monmouthshire, NP16 6DW	Public Open Space		520 sqm	n/a	n/a	Childrens Play area	Unsuitable
Woolpitch Wood Open Space (583.6 sqm)	Woolpitch Wood Open Space (583.6 sqm), Bayfield, Chepstow, Monmouthshire, NP16 6DW	Public Open Space		583 sqm	n/a	n/a	Childrens Play Area	Unsuitable
Woolpitch Wood Open Space (5846 sqm)	Woolpitch Wood Open Space (5846 sqm), Bayfield, Chepstow, Monmouthshire, NP16 6DW	Public Open Space		5846 sqm	n/a	Sloped	Playing Fields	Unsuitable
Wyebridge Street, Land at	Wyebridge Street, Land at, Monmouth, Monmouthshire, NP25 3DL	Public Open Space	0.40 acres	1642 sqm	Flood Zone 2 River			Unsuitable - Flood risk
Wyesham Road Open Space	Wyesham Road Open Space, Wyesham, Monmouth, Monmouthshire, NP25 3JR	Public Open Space	2639 sqm	2639 sqm	n/a	n/a	n/a	Unsuitable
Yew Tree Rise (4972 sq m) Open Space	Yew Tree Rise (4972 sq m) Open Space, Rogiet, Caldicot, Monmouthshire, NP26 3TJ	Public Open Space	4972 sqm	4972 sqm	n/a	n/a	Childrens Play Area	Unsuitable
Chippenham & Beech Close Allotments	Chippenham & Beech Close Allotments, Beech Road, Monmouth, Monmouthshire, NP25 3EQ	Allotments		Allotments				
Llanfoist Allotments	Llanfoist Allotments, Merthyr Road, Llanfoist, Abergavenny, Monmouthshire, NP7 9NX	Allotments		Allotments				
Sandy Lane Allotments	Sandy Lane Allotments, Caldicot, Monmouthshire	Allotments		Allotments				
Strongbow Road Allotments	Strongbow Road Allotments, Strongbow Road, Chepstow, Monmouthshire	Allotments		Allotments				
Sycamore Terrace Allotments	Sycamore Terrace Allotments, Sycamore Terrace, Undy, Magor, Monmouthshire	Allotments		Allotments				
Usk Allotments	Usk Allotments, Monmouth Road, Usk, Monmouthshire	Allotments		Allotments				
Forge Hammer Inn, Land near	Forge Hammer Inn, Land near, Heads of the Valley Road, Gilwern, Abergavenny, Monmouthshire, NP7	Land?	?	Too small	n/a	n/a	n/a	Unsuitable
Grosvenor Road, Land at	Grosvenor Road, Land at, Abergavenny, Monmouthshire, NP7 6AH	Land	?	Too Small	n/a	n/a	n/a	Unsuitable
Old Abergavenny Road, Land at	Old Abergavenny Road, Land at, Pencroesoped, Abergavenny, Monmouthshire, NP7 9EL	Land	?	Too Small	n/a	n/a	n/a	Unsuitable
Chippenham Mead Village Green	Chippenham Mead Village Green, Monmouth, Monmouthshire, NP25 3EQ	Land	0.11km	0.11km	Yes	n/a	Playing Fields	Unsuitable
Drybridge Nature Park	Drybridge Nature Park, Rockfield Road, Monmouth, Monmouthshire	Land	15383 sqm	15383sqm	C1 Flood Risk	n/a	Playing Fields	Unsuitable
Lawrence Crescent Amenity Land	Lawrence Crescent Amenity Land, Caerwent, Caldicot, Monmouthshire, NP26 5NS	Land	2234 sqm	2234 sqm	n/a	n/a	Childrens Play Area	Unsuitable
Linda Vista Gardens	Linda Vista Gardens, Tudor Street, Abergavenny, Monmouthshire, NP7 5DL	Land	12097sqm	12097sqm	AN 2 Flood Zone	n/a	N/A	Unsuitable
Former Clydach School, land adjacent	Former Clydach School, land adjacent, Off Heads of the Valley Road, Clydach, Monmouthshire, NP& 0LL	Land		Irregular shape - Too small	n/a	n/a	n/a	Unsuitable
Portal Road, Land at	Portal Road, Land at, Monmouth, Monmouthshire	Land. Declared surplus and on the market.	1.29 acres	Development Site. Declared	n/a	n/a	n/a	Unsuitable
1.85 acres at Dancing Hill, Undy	1.85 Caled Llawr, Dancing Hill, Undy, CALDICOT, NP26 3BY	Agricultural, Bare Land	1.85 acres	7486 sqm	No			Next stage
10/11/12/Pt13/34/9 Leechpool	Leechpool 10/11/12/Pt13/34/9, Rear of 9 Leechpool Holdings, Crick, Caldicot, Monmouthshire, NP26 5TZ	Agricultural, Bare Land	34.5 acres	34.5 acres	n/a	n/a	n/a	CORE ESTATE
12 acres of land South of Trelleck	12 acres of South of Trelleck, Trelleck, Monmouth, Monmouthshire, NP25 4PF	Agricultural, Bare Land	12 acres	48,562 sqm	Flood Zone 3 Rivers on edge of site but boundary could exclude			Next stage
2A/2B Caldicot	Caldicot 2A/2B, Slough Farm, Caerwent, Caldicot, Monmouthshire, NP26 5NW	Agricultural, Bare Land	53 acres	53 acres	n/a	n/a	n/a	CORE ESTATE
42 Leechpool	Leechpool 42, Lower Leechpool Farm, Portskewett, Caldicot, Monmouthshire, NP26 5UB	Agricultural, Bare Land	37.7 acres	37.7 acres	n/a	n/a	n/a	CORE ESTATE
5 Llanfair Discoed	Llanfair Discoed 5, Llanfair Farm, Llanfair Discoed, Chepstow, Monmouthshire, NP16 6LX	Agricultural, Bare Land	14 acres	14 acres	n/a	n/a	n/a	CORE ESTATE
7.27 acres at Dancing Hill, Undy	7.27 , Magor, CALDICOT	Agricultural, Bare Land	7.27 acres	29,420 sqm	Western boundary in Zones 2 & 3 Sea and Zone 2 River but boundary could be amended to exclude			Next stage

8/9/4 Undy	Undy 8/9/4, Oaklands Farm, Llanfair Discoed, Chepstow, Monmouthshire, NP16 6LX	Agricultural, Bare Land	58.5 acres	58.5 acres	n/a	n/a	n/a	CORE ESTATE
Caerwent 10	Caerwent 10, Slough Farm, Caerwent, Caldicot, Monmouthshire, NP26 5NW	Agricultural, Bare Land	11 acres	11 acres	n/a	n/a	n/a	CORE ESTATE
Caerwent 3A	Caerwent 3A, Slough Farm, Caerwent, Caldicot, Monmouthshire, NP26 5NW	Agricultural, Bare Land	11.3 acres	11.3 acres	n/a	n/a	n/a	CORE ESTATE
OS 4594 at Ifton Hill	OS 4594 at Ifton Hill, Ifton Hill, Caldicot, NP26 5TU	Agricultural, Bare Land	10.77 acres	10.77 acres	Partially	n/a	n/a	CORE ESTATE
OS 5223 at Ty Mawr	OS 5223 at Ty Mawr, Gilwern, Abergavenny, Monmouthshire	Agricultural, Bare Land	8.4 acres	8.4 acres	n/a	n/a	n.a	CORE ESTATE
Pt10/13 Llanfair Discoed	Llanfair Discoed Pt10/13, Lower House Farm, Kemys Commander, Usk, Monmouthshire, NP15 1JU	Agricultural, Bare Land	33.3 acres	33.3 acres	n/a	n/a	n/a	CORE ESTATE
Ty Mawr School Farm	Ty Mawr School Farm, Gilwern, Abergavenny, Monmouthshire, NP7 0EB	Agricultural, Bare Land	29.6 acres	29.6 acres	n/a	n/a	n/a	CORE ESTATE
3 Brooks Farm	3 Brooks Farm, Raglan, Usk, Monmouthshire, NP15 2HX	Agricultural, Dairy	1112 acres	1112 acres	Partially	n/a	n/a	CORE ESTATE
4 Hayesgate Lane	4 Hayesgate Lane, Mathern, Chepstow, Monmouthshire, NP16 6LJ	Agricultural, Dairy	94 acres	94 acres	n/a	n/a	n/a	CORE ESTATE
4 Llanddewi Court	4 Llanddewi Court, Llanddewi Skirrid, Abergavenny, Monmouthshire, NP7 8AL	Agricultural, Dairy	103 acres	104 acres	n/a	Sloped	n/a	CORE ESTATE
5 Llanddewi Court	5 Llanddewi Court, Llanddewi Skirrid, Abergavenny, Monmouthshire, NP7 8AL	Agricultural, Dairy	137 acres	138 acres	n/a	Sloped	n.a	CORE ESTATE
Greenmeadow Farm	Greenmeadow Farm, Greenmeadow Fm, Hayesgate, Mathern, Chepstow, Monmouthshire, NP16 6LL	Agricultural, Dairy	89.9 acres	89.9 acres	n/a	n/a	n/a	CORE ESTATE
Ifton Hill Farm	Ifton Hill Farm, Ifton Hill Farm, Portskewett, Caldicot, Monmouthshire, NP26 5TT	Agricultural, Dairy	137 acres	137 acres	n/a	n/a	n/a	CORE ESTATE
Lower House Farm	Lower House Farm, Lower House Farm, Llanfair Discoed, Chepstow, Monmouthshire, NP16 6LY	Agricultural, Dairy	117 acres	117 acres	n/a	n/a	n/a	CORE ESTATE
Lower Leechpool Farm	Lower Leechpool Farm, Lower Leechpool Farm, Portskewett, Caldicot, Monmouthshire, NP26 5UB	Agricultural, Dairy	80.1 acres	80.1 acres	n/a	n/a	n/a	CORE ESTATE
Old Llanishen Farm	Old Llanishen Farm, Old Llanishen Farm, Llangovan, Monmouth, Monmouthshire, NP25 4BU	Agricultural, Dairy	88 acres	89 acres	n/a	n/a	n/a	CORE ESTATE
Penarth Farm	Penarth Farm, Penarth Farm, Llanishen, Monmouth, Monmouthshire, NP16 6QH	Agricultural, Dairy	69.9 acres	69.9 acres	n/a	n/a	n.a	CORE ESTATE
Rodge Farm	Rodge Farm, Rodge Farm, Caerwent, Caldicot, Monmouthshire, NP26 5PB	Agricultural, Dairy	164.5 acres	164.5 acres	n/a	n/a	n/a	CORE ESTATE
Slough Farm	Slough Farm, Slough Farm, Caerwent, Caldicot, Monmouthshire, NP26 5NW	Agricultural, Dairy	57.2 acres	57.2 acres	n/a	n/a	n/a	CORE ESTATE
3 Llanddewi Court	3 Llanddewi Court, Llanddewi Skirrid, Abergavenny, Monmouthshire, NP7 8AL	Agricultural, Equestrian Training School	37.6 acres	37.6 acres	n/a	n/a	n/a	CORE ESTATE
0.81 acre at Dancing Hill	0.81 , Undy, Magor, Monmouthshire	Agricultural, Grazing	0.81 acres	3277 sqm	No			Next stage
1.24 hectares at Lower House Farm	1.24 , Llanfair Discoed, Chepstow, NP16 6LX	Agricultural, Grazing	3.06 acres	3.06 acres	n/a	n/a	n/a	CORE ESTATE
5.79 acres at rear of Langley Close M	5.79 , Magor, Monmouthshire	Agricultural, Grazing	5.79 acres	23,431 sqm	No			Next stage
Central Farm, 6.02 hectares at	Central Farm, 6.02 hectares at, Greenmeadow Fm, Hayesgate, Mathern, Chepstow, Monmouthshire, NP16 6LL	Agricultural, Grazing	14.8 acres	14.8 acres	n/a	n/a	n/a	CORE ESTATE
Central Farm, 9.51 hectares at	4 Hayesgate Lane, Mathern, Chepstow, Monmouthshire, NP16 6LJ	Agricultural, Grazing	23.49 acres	23.49 acres	n/a	n/a	n/a	CORE ESTATE
Central Farm, 9.92 hectares at	Central Farm, 9.92 hectares at, Slough Farm, Caerwent, Caldicot, Monmouthshire, NP26 5NW	Agricultural, Grazing	24.5 acres	24.5 acres	n/a	n/a	n/a	CORE ESTATE
Land adj Indian Empire restaurant	Land adj Indian Empire restaurant, Portskewett, Caldicot, NP26 5UT	Agricultural, Grazing	1.9 acres	1.9 acres	n/a	n/a	n/a	CORE ESTATE
OS6954 - 1.64 acres at Caerwent	OS6954 - 1.64 acres at Caerwent, Caerwent, CALDICOT, NP26 5PB	Agricultural, Grazing	1.64 acres	Too Small	n/a	n/a	n/a	Unsuitable
OS8959 adjacent The Cayo	OS8959 adjacent The Cayo, Red House Lane, Shirenewton, CHEPSTOW, NP16 6RL	Agricultural, Grazing	0.1 acres	Too small	n/a	n/a	n/a	Unsuitable
Penyffyddlwn Farm	Penyffyddlwn Farm, Llanelly Hill, Abergavenny, Monmouthshire	Agricultural, Grazing	???	n/a	n/a	Unfavourable topography	n/a	Unsuitable
Racecourse Farm, Land at	Racecourse Farm, Land at, Llanfoist, Abergavenny, Monmouthshire, NP7 9HE	Agricultural, Grazing	42.9 acres	42.9 acres	Yes	n/a	n/a	CORE ESTATE
Ty Mawr	Ty Mawr, Gilwern, Abergavenny, Monmouthshire, NP25 4RN	Agricultural, Grazing	8.4 acres	8.4 acres	n/a	n/a	n/a	CORE ESTATE
Chepstow Road Raglan MUGA	Brooks Farm 2, Brooklands, Raglan, Usk, Monmouthshire, NP15 2HX	Agricultural, Horticultural	3.62 acres	3.62 acres	n/a	MUGA - therefore unsuitable	n/a	Unsuitable
Crown Hill Nursery	Crown Hill Nursery, Crown Hill Nursery, Portskewett, Caldicot, Monmouthshire, NP26 5UU	Agricultural, Horticultural	14.1 acres	14.1 acres	n/a	n/a	n/a	CORE ESTATE

Gemini Nursery	14 Leechpool, Portskewett, Caldicot, Monmouthshire, NP26 5TX	Agricultural, Horticultural	13.2 acres	13.2 acres	n/a	n/a	n/a	CORE ESTATE
Windrush Nursery	Windrush Nursery, Windrush Nursery, Portskewett, Caldicot, Monmouthshire, NP26 5UU	Agricultural, Horticultural	7 acres	8 acres	n/a	n/a	n/a	CORE ESTATE
15/16 Portskewett	Portskewett 15/16, The Close, Portskewett, Caldicot, Monmouthshire, NP26 5SN	Agricultural, Grazing land	3.56 acres	3.56 acres	n/a	n/a	Recreation Area	Unsuitable
4 Caldicot	Caldicot 4, The Pill, Caldicot, Monmouthshire, NP26 5XG	Agricultural, Grazing land	20.2 acres	20.2 acres	Yes	n/a	n/a	Unsuitable
Great House Farm, Land at Caerwent	Great House Farm, Caerwent, Great House Farm 2, Caerwent, Caldicot, NP26 5AS	Agricultural, Grazing land	12.4 acres	12.4 acres	n/a	n/a	n/a	CORE ESTATE
Great House Farm, Land to the North	Great House Farm, Caerwent, Caerwent, Monmouthshire, NP26 5AS	Agricultural, Grazing land	0.5 acres	0.5 acres	n/a	n/a	n/a	CORE ESTATE
Undy Pt2 (0.20 acres)	Undy Pt2 (0.20 acres), Estates Section, @Innovation House P O Box 106, Caldicot, Monmouthshire, NP26 9AN	Public Open Space	0.2 acres	800sqm	Flood Zone 3 Sea on whole site and Surface Water on northern part of site.			Unsuitable - Flood Risk

Site Name and Address	Description on Asset Register	Area	Larger than 600sqm?	Inside Flood Zone 2 or 3 surface water in western corner	Within or adjoining a Settlement boundary	Greenfield/Brownfield	Surrounded by built development/privacym/amenity issues	Within BBNP or AONB	Within Green Wedge or Potential Green Belt	Within Phosphates Catchment Area	Adopted LDP DES2 Allocation	DES2 in Review Recommendation	Within/Adjacent to Conservation Area or Historic Park & Garden	Within ASA	Heritage designations (i.e. Con Area, Historic Park & Garden, ASA and SAs) (state if within and what the designation is, state what is within 500 metres of the site)	Ecological Designation on whole or part of site (SSSI, SAC, RAMSAR, national nature reserves)	Ecology (state if within SSSI or SINC or SAC or RAMSAR or National/Local Nature Reserve; note if within 500 metres of one of these designations)	Landscape sensitivity (state classification on Landscape Sensitivity Study)	Mineral safeguarding (state if within current adopted LDP safeguarding area)	Proximity to 'bad neighbours' (distance from dual carriageway road, trunk road, motorway, railway, industrial estate)	Contamination (viability of remediation) (state from MonMaps)	School proximity (state distance to catchment primary and secondary schools)	Medical facility proximity (state distance to nearest GP surgery)	Proximity to other amenities (e.g. shops) (state distance to nearest Main Town, Government Settlement or Rural secondary Settlement as identified in Sustainable Settlements RLPD Paper)	Public transport proximity (as set out in SSA) - Medium frequency service between 10 - 30 minutes; Low frequency service between 31 - 60 minutes; Daily frequency more than hourly (at least one in the morning and one in the afternoon)	Constrained by topography?	Vehicle Access (site specific checks later)	Ability to provide utility infrastructure (complete later)	Permanence (21 years) (later)	Scope for future expansion (if needed later)	Other Comments	
Blenheim Avenue Play area, Magor, Caldicot, NP26 3NB	Public Open Space	1.5 acres	6070 sqm	Section of Zone 2 & 3 surface water in western corner	Yes	Greenfield	Yes	No	No	No	DES2 Amenity land - Children's Play Area on portion of site	Retain with boundary amended to include second play area.	No	Yes	Listed buildings within 150m; within Gwent Levels ASA	No	No	None	Within settlement boundary of Magor	No	Residential area	None	Magor VA CIW Primary - 0.3 miles; Caldicot Comp - 4.6 miles	0.6 miles	Within 150m to Magor Town Centre	Low and daily frequency bus services available. Train services available from Severn Tunnel					Children's Play Area on portion of the site	
Lawrence Crescent Play area, Caerwent, Caldicot, NP26 5NS	Public Open Space	0.55 acres	2225sqm	No	Yes	Greenfield	No - residential development to south and west. C/S to north and east	No	Potentially Green Belt	No	50% DES2 Amenity land situated outside the development boundary. Children's Play Area on portion of site	Retain with boundary amendment to include the whole site.	No	Yes	Caerwent ASA; Listed Buildings within 300m; Scheduled Ancient Monument within 350m	No	No	Within 250m of SINC	Half the site within the development boundary and half outside. Landscape Sensitivity Study treats whole site as within settlement boundary	No	Edge of residential area; Caerwent MOD site within 300m	None	Rogiet Primary 3.6 miles; Chepstow Comp 5.7 miles	3.5 miles	Approx. 3 miles to Caldicot Town Centre	Low frequency bus service available					Children's Play Area on portion of site	
Strongbow Road Play Area, Chepstow	Public Open Space	2.1 acres	8498sqm	No	Yes	Greenfield	No - Allotments and woodland to east of site	No	No	No	DES2 Amenity land	Retain DES2 designation.	No	No	Listed Building within 450m; Scheduled Ancient Monument within 350m	No	No	Within 100m of group TPO; within 150m of SINC	Within development boundary of Chepstow	No	Residential area, train line within 200m	None	Pembroke Primary - 0.2 miles; Chepstow Comprehensive - 1.1 miles	0.6 miles	Approx. 150m to Bulwark Neighbourhood Shopping Centre	Low and daily bus services available. Chepstow train station and services available.					Adjoining allotments	
Alice Crescent Public Open Space 1668 sq m, Chepstow, NP16 5SW	Public Open Space	0.41 acres	1659sqm	No	Yes	Greenfield	Yes	No	No	No	DES2 Amenity land	Retain DES2 designation.	No	No	10m to Schedule Ancient Monument; Listed Building within 142m	No	No	Within 100m of group TPO; within 235m of SINC	Within development boundary of Chepstow	No	Residential area, within 300m of M48	None	Thornwell Primary - 0.6 miles; Chepstow Comp - 3 miles	2.4 miles	Approx. 150m to Thornwell Neighbourhood Shopping Centre	Low and daily bus services available. Chepstow train station and services available.	Flat					
Ash Grove Public Open Space, Caldicot, NP26 4NG	Public Open Space	0.22 acres	895 sqm	No	Yes	Greenfield	Yes	No	No	No	DES2 Amenity land	Designate as DES2	No	No	Within 500m of Dewstow House Historic Parks and Garden	No	No	None	Within development boundary of Caldicot	No	Residential area, within 300m of M48	None	Dewstow Primary - 0.3 miles; Caldicot Comprehensive - 1 mile	0.9 miles	Approx. 500m to Caldicot Town Centre	Low frequency bus service available. Caldicot train and services available.	Flat					
Beaupreau Place Public Open Space, Abergavenny, NP7 5LZ	Public Open Space	1.53 acres	6191sqm	Small area Zone 3 Rivers in northern section of site but could be excluded	Yes	Greenfield - woodland	Residential development to east and south; site and land to north are woodland.	No	No	River Usk Catchment	DES2 Amenity Land	Retain DES2 designation with boundary amendment to exclude residential curtilages.	Yes	No	Within 200m of Bailey Park Historic Parks and Gardens; Listed Building within 85m; adjacent to ASA; within Abergavenny Pen-y-Fal Conservation Area	No	Yes	Site covered by group TPO; SINC River Gaverenni / Woodland	Within development boundary of Abergavenny	No	Residential area	Cemetery or Graveyard Contaminated Land Plint on site	Deer View Primary - 1.7 miles; King Henry VIII Comprehensive - 1.4 miles	0.5 miles	Approx. 300m to Abergavenny Town Centre	Low and daily bus services available. Abergavenny train station and service available.					Woodland	
Bigham Close Public Open Space, Monmouth, NP25 5DP	Public Open Space	0.3	1278sqm	Approximately half of site is Zone 2 Rivers	Yes	Greenfield	Yes	No	No	River Wye Catchment	DES2 Amenity Land	Designate as DES2 as part of larger Kingswood Road designation.	No	No	None	No	No	Within 100m to group TPO; 318m to SINC	Within development boundary of Monmouth	No	Residential area	None	Overmonnow Primary - 0.5 miles; Monmouth Comprehensive 1.5 miles	1 mile	Approx. 0.5 miles to Monmouth Town Centre	Daily frequency bus service available.					Adjoins a Childrens Play Area	
Bishops Close (4277 sq m) Public Open Space, Chepstow, NP16 5TE	Public Open Space	1.05 acres	4229sqm	No	Yes	Greenfield	Yes	No	No	No	DES2 Amenity Land	Designate as DES2.	No	No	Within 120m of Scheduled Ancient Monument	No	Yes	Group TPO on site; 220m to SINC / Woodland	Within development boundary of Monmouth	No	Residential area, within 350m of railway line	None	Thornwell Primary - 0.6 miles; Chepstow Comprehensive - 3 miles	2.4 miles	Approx. 150m to Thornwell Neighbourhood Shopping Centre	Low and daily bus services available. Chepstow train station and services available.	Sloped in various places. Potential for smaller plot to be created on portion					Woodland on large portion of site
Cae Denw Public Open Space (1130sqm), Gilwern, Abergavenny, NP7 0BJ	Public Open Space	0.27 acres	1092sqm	No	Yes	Greenfield	Residential to north, south and west. Fields to east.	Brecon Beacons National Park	No	River Usk Catchment	No	BBNP LPA - not part of review.	No	No	None	No	No	None	Within settlement of Gilwern; BBNP	No	Residential area	None	Gilwern Primary - 0.5 miles; King Henry VIII Comp - 4.9 miles	0.4 miles	Approx. 0.5 miles to Main Road, Gilwern	Rural - Gilwern not in the SSA						
Cae Denw Public Open Space (701 sqm), Gilwern, Abergavenny, NP7 0BJ	Public Open Space	0.17 acres	687sqm	No	Yes	Greenfield	Yes	Brecon Beacons National Park	No	River Usk Catchment	No	BBNP LPA - not part of review.	No	No	None	No	No	None	Within settlement of Gilwern; BBNP	No	Residential area	None	Gilwern Primary - 0.5 miles; King Henry VIII Comp - 4.9 miles	0.4 miles	Approx. 0.5 miles to Main Road, Gilwern	Rural - Gilwern not in the SSA						
Caerwent Lane (3615 sq m) Public Open Space, Chepstow, NP16 5TQ	Public Open Space	0.89 acres	3601sqm	Zone 3 Surface Water on most of site	Yes	Greenfield	Residential to north and east. M48 to south and Beaufort Park employment site to west.	No	No	No	No	Not reviewed/no change	No	No	Scheduled Ancient Monument within 120m	No	No	None	Within development boundary of Chepstow	No	Opposite Beaufort Park Employment site; adjacent to M48; Residential area to north and east of site	Contaminated Land Line running across southern section of site	Thornwell Primary - 0.4 miles; Chepstow Comp - 2.7 miles	2.3 miles	Approx. 150m to Thornwell Neighbourhood Shopping Centre	Low and daily bus services available. Chepstow train station and services available.						
Church Road Public Open Space, Church Road, Caldicot	Public Open Space	0.7 acres	2832sqm	Small area in Zone 3 Sea in eastern section of site but could be excluded	Yes	Greenfield	Yes	No	No	No	DES2 Amenity Land	Designate as DES2 (Llantrisy Secunda Manor)	No	No	Scheduled Ancient Monument within 300m; Listed Building opposite site	No	No	SSSI within 250m	Within development boundary of Caldicot	No	Residential area	None	Castle Park Primary - 0.4 miles; Caldicot Comp - 1 mile	0.7 miles	Approx. 0.5 miles to Caldicot Town Centre	Low and daily bus services available. Caldicot train station and services available.						
Cobb Crescent Public Open Space, Caldicot, NP26 5BY	Public Open Space	0.13 acres	551 sqm	No	Yes	Greenfield	Yes	No	No	No	DES2 Amenity Land	Should not be designated as DES2.	No	No	None	No	No	None	Within development boundary of Caldicot	No	Residential area	None	Durand Primary - 0.2 miles; Caldicot Comp - 0.3 miles	0.3 miles	Approx. 350m to West End Neighbourhood Centre; approx 400m to Caldicot Town Centre	Low and daily bus services available. Caldicot train station and services available.						
Cybi Drive Public Open Space, Llanybi, Usk, NP15 1TU	Public Open Space	0.19 acres	796 sqm	No	Yes	Greenfield	Yes	No	Potentially Green Belt	River Usk Catchment	No	Not reviewed/no change	No	No	Listed Building within 200m	No	No	None	Within village boundary of Llanybi	No	Residential area	None	Usk CV - 3.4 miles; Monmouth Comp - 17.3 miles	3.2 miles	Rural Secondary Settlement Usk - approx 3 miles	Daily frequency bus service available.	Flat					
Cybi Rise Open Space, Llanybi, Usk, NP15 1TU	Public Open Space	0.16 acres	672 sqm	No	Yes	Greenfield	Yes	No	Potentially Green Belt	River Usk Catchment	No	Should not be designated as DES2.	No	No	Listed Building within 200m	No	No	None	Within village boundary of Llanybi	No	Residential area	None	Usk CV - 3.4 miles; Monmouth Comp - 17.3 miles	3.2 miles	Rural Secondary Settlement Usk - approx 3 miles	Daily frequency bus service available.	Flat					
Fountain Way (1478 sq m) Public Open Space, Chepstow, NP16 5SZ	Public Open Space	0.365 acres	1478 sqm	No	Yes	Greenfield	Yes	No	No	No	DES2 Amenity Land	Designate as DES2.	No	No	Scheduled Ancient Monument on site and also within 500m	No	No	Approx 400m away from SINC	Within development boundary of Chepstow	No	Residential area, approx 200m from M48	None	Thornwell Primary - 0.3 miles; Chepstow Comp - 2 miles	2 miles	200m to Thornwell Neighbourhood Centre; approx 1.3 miles to Chepstow Town Centre	Low and daily bus frequency services available. Chepstow train station and services available.						
Lancaster Way Public Open Space, Osbaston, Monmouth, NP25 3BE	Public Open Space	1.22 acres	4943 sqm	Zone 3 Surface Water running along northern boundary	Adjoining	Greenfield	Residential to east and west. Fields to north and west.	No	No	River Wye Catchment	DES2 Amenity land	Retain as DES2.	No	No	None	No	No	None	Within LLCA M05 - High/medium sensitivity to residential development	No	Edge of residential area and countryside	None	Osbaston CIW Primary - 0.2 miles; Monmouth Comp - 1.2 miles	1.1 miles	1 mile to Monmouth Town Centre	Daily frequency bus service available.	Sloping - potential for smaller plot					
Orchid Drive Open Space, Caldicot, NP26 5GE	Public Open Space	3.4 acres	14,500 sqm	No	Adjoining	Greenfield	Residential to north, east and west. Railway line and Gwent Levels to south.	No	No	No	DES2 Amenity land. Children's Play Area on part of site.	Retain as DES2 with boundary amendments to exclude houses and road.	No	No	Scheduled Ancient Monument within 500m	No	Yes	Western half of site is SINC; within 200m of SSSI	Treated as within the development boundary for the Landscape Sensitivity Study; adjoins LLCA CA05 - high/medium sensitivity to housing	No	15m from mainline railway to south; residential area to north and west; Severn Bridge Employment site adjoining eastern boundary	Contaminated Land Poly on western half of site	Durand Primary - 0.8 miles; Caldicot Comp - 0.8 miles	1.2 miles	0.5 miles to Caldicot Town Centre	Low and daily frequency bus service available. Train services available from Severn Tunnel Junction					Childrens equipped play area on small area	
St Tysol Close Public Open Space, Llansoy, Usk, NP15 1EF	Public Open Space	0.72 acres	2978 sqm	No	No	Greenfield	Yes	No	No	River Usk Catchment	No	Designate as DES2.	No	No	Within 200m of Listed Buildings	No	No	Within 100m of SINC	Sensitivity not specified in Updated Landscape Study.	No	Residential Village	None	Shirenewton Primary - 7.4 miles; Chepstow Comp - 8.5 miles	5.5 miles	5.5 miles to Usk Town Centre	Included in Llansoy in SSA - Daily frequency bus service					Trees covering site	
Toynbee Way Public Open Space, Osbaston, Monmouth NP25 3NU	Public Open Space	0.19 acres	780 sqm	No	Yes	Greenfield	Yes	No	No	River Wye Catchment	No	Not reviewed/no change	No	No	Within 100m of Monmouth Conservation Area	No	No	Within 200m of SINC	Within development boundary of Monmouth	No	Residential area	None	Osbaston CIW Primary - 0.2 miles; Monmouth Comp - 0.8 miles	0.8 miles	0.8 miles to Monmouth Town Centre	Daily frequency bus service available.						
Walls Close Public Open Space, Osbaston, Monmouth, NP25 3NS	Public Open Space	0.23 acres	952 sqm	No	Yes	Greenfield	Yes	No	No	River Wye Catchment	No	Not reviewed/no change	No	No	Within 500m of Monmouth Conservation Area	No	No	Within 300m of SINC	Within development boundary of Monmouth	No	Residential area	None	Osbaston CIW Primary - 0.3 miles; Monmouth Comp - 0.9 miles	0.9 miles	0.9 miles to Monmouth Town Centre	Daily frequency bus service available.						
Berryfield Close Open Space, Osbaston, Monmouth, NP25 3JG	Public Open Space	0.29 acres	1185 sqm	No	Yes	Greenfield	Yes	No	No	River Wye Catchment	No	Not reviewed/no change	No	No	None	No	No	None	Within development boundary of Monmouth	No	Residential area	None	Osbaston CIW Primary 0.8 miles; Monmouth Comp - 1.3 miles	1.2 miles	1.5 miles to Monmouth Town Centre	Daily frequency bus service available.					Large tree in centre of site	
Blethyn Close Open Space, Mynydd Bach, Shirenewton, Chepstow, NP16 6SW	Public Open Space	3.57 acres	14466 sqm	No	Adjoining	Greenfield	Residential to north and east. Fields to south and west.	No	Green Belt	No	DES2 Amenity Land	Retain as DES2	No	No	None	No	No	None directly - SINC to immediate south & west	Sensitivity not specified in Updated Landscape Study.	No	None	None	Shirenewton Primary - 0.3 miles; Chepstow Comp - 3.5 miles	4 miles	3 miles to Chepstow Town Centre	Daily frequency bus service available.						
Brookside Open Space, Neddem Way, Caldicot, NP26 4NJ	Public Open Space	3.59 acres	14539 sqm	No	Adjoining	Greenfield	Residential to east, south and west. Woodland/buffer and M48 to north.	No	No	No	DES2 Amenity Land	Delete this part of the DES2 designation (Sandy Lane 8).	No	No	Within 400m of Scheduled Ancient Monument	No	No	Within 300m of SINC	LLCA CA03 - High/medium sensitivity to residential development	Limestone Mineral Safeguarding Area	M48 within 50m	None	Castle Park Primary - 0.4 miles; Caldicot Comp - 1.2 miles	1.2 miles	1.3 miles to Caldicot Town Centre	Low and daily frequency bus service available. Train services available from Severn Tunnel Junction						
Castle Oak (842.9 sq m) Open Space, Usk, NP15 1SG	Public Open Space	0.20 acres	842 sqm	No	Yes	Greenfield	Yes	No	No	River Usk Catchment	No	Not reviewed/no change	No	No	Within 300m of Usk Conservation Area and ASA	No	No	Within 100m of SINC	Within development boundary of Usk	No	Residential area	None	Usk CV Primary - 0.4 miles; Monmouth Comp - 15 miles	0.7 miles	0.7 miles to Usk Town Centre	Daily frequency bus service available.						
Crossconen Parc Public Open Space, Abergavenny, NP7 6PF	Public Open Space	1.95 acres	7891 sqm	Small area of zone 3 surface water	Adjoining	Greenfield	Residential to west. Open space/woodland to other boundaries.	No	No	River Usk Catchment	No	Designate as DES2.	No	No	None	No	No	SINCs immediately adjacent. Cwm Mill SSSI within 500m; Group TPO covering site	LLCA A01 - High/medium sensitivity to residential development	No	A465 and railway line within 300m. Allocated employment site within 300m.	Contaminated Land Poly on adjacent land	Deer View Primary - 0.8 miles; King Henry VIII Comp - 1.1 miles	0.8 miles	0.3 miles to Rother Avenue Neighbourhood Centre; 0.7 miles to Abergavenny Town Centre	Frequent bus services. Train station with frequent services within Abergavenny.						
Garth Close Open Space, Mitchel Troy, Monmouth, NP25 4JN	Public Open Space	1.56 acres	6318 sqm	No	No	Greenfield	Residential to north, east and south. Fields to west.	Wye Valley AONB	No	River Wye Catchment	No	Not reviewed/no change	No	No	Listed building within 500m	No	No	SINCs within 500m	Adjacent to LCA MT01 which is identified as high/medium sensitivity	No	Edge of Minor Village of Mitchel Troy	None	Kymin Primary 5.1 miles; Monmouth Comp - 3.4 miles	3.4 miles	2.8 miles to Monmouth Town Centre	Daily frequency bus service available.						
High Beech Lane Open Space, Chepstow, NP16 5BQ	Public Open Space	0.27 acres	1095 sqm	No	Yes	Greenfield	Yes	No	No	No	DES2 Amenity Land	Not reviewed/no change	No	No	Wyetlands Historic Park and Garden and Mathern CA within 500m of the site	No	No	None	Within development boundary of Chepstow	No	Residential area. Approx. 250m to Wye Valley Link Road. AQMA within 500m. Protected Employment Site within 500m (Bulwark Road)	Contaminated Land Poly within 100m	Pembroke Primary - 0.4 miles; Chepstow Comp - 1.2 miles	0.6 miles	400m to Bulwark Neighbourhood Centre; 0.7 miles to Chepstow Town Centre	Low and daily bus frequency services available. Chepstow train station and services available.						





Site Name and Address	Description on Asset Register	Area	Larger than 500sqm?	Inland Flood Zone	Within or adjoining a Settlement boundary	Greenfield/brownfield	Surrounded by built development/privacy/amenity issues	Within BBNP or AONB	Within Green Wedge or potential Green Belt	Within Phosphates Catchment Area	DES2 Allocation	DES2 in Review Recommendation	Within/adjacent to Conservation Area or Historic Park & Garden	Within ASA	Heritage designations (LB, Con Area, Historic Park & Garden, ASA and SAs) (note if within and what the designation is)	Ecological Designation on whole or part of site (SSSI, SAC, RAMSAR)	Ecology (state if within SSSI or SINC or SAC or RAMSAR or National/Local Nature Reserve, note if within 500 metres of one of these)	Landscape sensitivity (state classification on Landscape Sensitivity Study)	Mineral safeguarding (state if within current adopted LDP safeguarding area)	Proximity to 'bad neighbours' (distance from dual carriageway road, trunk road, motorway, railway, industrial estate)	Contamination (viability of remediation) (state from MonMaps)	School proximity (state distance to catchment primary and secondary schools)	Medical facility proximity (state distance to nearest GP surgery)	Proximity to other amenities (e.g. shops) (state distance to nearest Main Town, Seaside Settlement or Rural Settlement)	Public transport proximity and frequency (as set out in SSA) - Medium frequency - services between 10 - 30 minutes; Low frequency bus services available	Constrained by topography?	Access (site specific checks later)	Ability to provide utility infrastructure (check later)	Permanent (21 years+)	Scope for future expansion (if needed later)	Other Comments	
Lawrence Crescent Play Area, Caerwent, Caldicot, NP26 5NS	Public Open Space	0.55 acres	2225sqm	No	Yes	Greenfield	No - residential development to south and west. C/S to north and east	No	Potentially Green Belt	No	50% DES2 Amenity land situated outside the development boundary. Children's Play Area on portion of site	Retain with boundary amendment to include the whole site.	No	Yes	Caerwent ASA; Listed Buildings within 300m; Scheduled Ancient Monument within 350m	No	No	Within 250m of SINC	No	Edge of residential area; Caerwent MOD site within 300m	None	Rogier Primary 3.6 miles; Chepstow Comp 5.7 miles	3.5 miles	Approx. 3 miles to Caldicot Town Centre	Low frequency bus service available					Childrens Play Area on portion of site		
Strongbow Road Play Area, Chepstow	Public Open Space	2.1 acres	8498sqm	No	Yes	Greenfield	No - Allotments and woodland to east of site	No	No	No	DES2 Amenity land	Retain DES2 designation.	No	No	Listed Building within 450m; Scheduled Ancient Monument within 350m	No	No	Within 100m of group TPO; within 150m of SINC	No	Residential area, train line within 200m	None	Pembroke Primary - 0.2 miles; Monmouth Comprehensive - 1.1 miles	0.6 miles	Approx. 150m to Bulwark Neighbourhood Shopping Centre	Low and daily bus services available. Chepstow train station and services available.					Adjoining allotments		
Beauveau Place Public Open Space, Abergavenny, NP7 5LZ	Public Open Space	1.53 acres	6191sqm	Small area Zone 3 Rivers in northern section of site but could be excluded	Yes	Greenfield - woodland	Residential development to east and south; site and land to north are woodland.	No	No	River Usk Catchment	DES2 Amenity Land	Retain DES2 designation with boundary amendment to exclude residential curtilages.	Yes	No	Within 200m of Bailey Park Historic Parks and Gardens; Listed Building within 85m; adjacent to ASA; within Abergavenny Pen-y-Fal Conservation Area	No	Yes	Site covered by group TPO; SINC River Gaverini / Woodland	No	Residential area	Cemetery or Graveyard Contaminated Land Plonk on site	Deri View Primary - 1.7 miles; King Henry VIII Comprehensive - 1.4 miles	0.5 miles	Approx. 300m to Abergavenny Town Centre	Low and daily bus services available. Abergavenny train station and service available.					Woodland		
Cae Derw Public Open Space (1130sqm), Gilwern, Abergavenny, NP7 0BJ	Public Open Space	0.27 acres	1062sqm	No	Yes	Greenfield	Residential to north, south and west. Fields to east.	Brecon Beacons National Park	No	River Usk Catchment	No	BBNP LPA - not part of review.	No	No	None	No	No	None	Within settlement of Gilwern; BBNP	No	Residential area	None	Gilwern Primary - 0.5 miles; Monmouth Comp - 4.9 miles	0.4 miles	Approx 0.5 miles to Main Road, Gilwern	Rural - Gilwern not in the SSA						
Caerwent Lane (3615 sq m) Public Open Space, Chepstow, NP16 5TQ	Public Open Space	0.89 acres	3601sqm	Zone 3 Surface Water on most of site	Yes	Greenfield	Residential to north and east. M48 to south and Beaufort Park employment site to west.	No	No	No	No	Not reviewed/no change	No	No	Scheduled Ancient Monument within 120m	No	No	None	Within development boundary of Chepstow	No	Opposite Beaufort Park Employment site; adjacent to M48; Residential area to north and east of site	Contaminated Land Line running across southern section of site	Thornwell Primary - 0.4 miles; Chepstow Comp - 2.7 miles	2.3 miles	Approx 150m to Neighbourhood Shopping Centre	Low and daily bus services available. Chepstow train station and services available.						
Lancaster Way Public Open Space, Osbaston, Monmouth, NP25 3BE	Public Open Space	1.22 acres	4943 sqm	Zone 3 Surface Water running along northern boundary	Adjoining	Greenfield	Residential to east and west. Fields to north and west.	No	No	River Wye Catchment	DES2 Amenity land	Retain as DES2.	No	No	None	No	No	None	Within LLCA M05 - High/medium sensitivity to residential development	No	Edge of residential area and countryside	None	Osbaston CIW Primary - 0.2 miles; Monmouth Comp - 1.2 miles	1.1 miles	1 mile to Monmouth Town Centre	Daily frequency bus service available.	Sloping - potential for smaller plot					
Orchid Drive Open Space, Caldicot, NP26 5GE	Public Open Space	3.4 acres	14,500 sqm	No	Adjoining	Greenfield	Residential to north, east and west. Railway line and Gwent Levels to south.	No	No	No	DES2 Amenity land. Children's Play Area on part of site.	Retain as DES2 with boundary amendments to exclude houses and road.	No	No	Scheduled Ancient Monument within 500m	No	Yes	Western half of site is SINC; within 200m of SSSI	Treated as within the development boundary for the Landscape Sensitivity Study; adjoins LLCA CA05 - high/medium sensitivity to housing	No	15m from mainline railway to south; residential area to north and west; Severn Bridge Employment site adjoining eastern boundary	Contaminated Land Poly on western half of site	Durand Primary - 0.8 miles; Caldicot Comp - 0.8 miles	1.2 miles	0.5 miles to Caldicot Town Centre	Low and daily frequency bus services available. Train services available from Severn Tunnel Junction					Childrens equipped play area on small area	
Blethyn Close Open Space, Shirenewton, Chepstow, NP16 6SW	Public Open Space	3.57 acres	14486 sqm	No	Adjoining	Greenfield	Residential to north and east. Fields/c/s to south and west.	No	Green Belt	No	DES2 Amenity Land	Retain as DES2	No	No	None	No	No	None directly - SINC to immediate south & west	Sensitivity not specified in Updated Landscape Study.	No	None	Shirenewton Primary - 0.3 miles; Chepstow Comp - 3.5 miles	4 miles	3 miles to Chepstow Town Centre	Daily frequency bus service available.							
Brookside Open Space, Neddern Way, Caldicot, NP26 4NJ	Public Open Space	3.59 acres	14539 sqm	No	Adjoining	Greenfield	Residential to east, south and west. Woodland/buffer and M48 to north.	No	No	No	DES2 Amenity Land	Delete this part of the DES2 designation (Sandy Lane 6).	No	No	Within 400m of Scheduled Ancient Monument	No	No	Within 300m of SINC	LLCA CA03 - High/medium sensitivity to residential development	Limestone Mineral Safeguarding Area	M48 within 50m	None	Castle Park Primary - 0.4 miles; Caldicot Comp - 1.2 miles	1.2 miles	1.3 miles to Caldicot Town Centre	Low and daily frequency bus services available. Train services available from Severn Tunnel Junction.						
Croesonen Parc Public Open Space, Abergavenny, NP7 6PF	Public Open Space	1.95 acres	7891 sqm	Small area of zone 3 surface water	Adjoining	Greenfield	Residential to west. Open space/woodland to other boundaries.	No	No	River Usk Catchment	No	Designate as DES2.	No	No	None	No	No	SINCs immediately adjacent. Cwm Mill SSSI within 500m; Group TPO covering site	LLCA A01 - High/medium sensitivity to residential development	No	A465 and railway line within 300m. Allocated employment site within 300m.	Contaminated land poly on adjacent land	Deri View Primary - 0.8 miles; King Henry VIII Comp - 1.1 miles	0.8 miles	0.3 miles to Rother Avenue Neighbourhood Centre; 0.7 miles to Abergavenny Town Centre	Frequent bus services. Train station with frequent services within Abergavenny.						
Garth Close Open Space, Mitchel Troy, Monmouth, NP25 4JN	Public Open Space	1.56 acres	6318 sqm	No	No	Greenfield	Residential to north, east and south. Fields to west.	Wye Valley AONB	No	River Wye Catchment	No	Not reviewed/no change	No	No	Listed building within 500m	No	No	SINCs within 500m	Adjacent to LCA MT01 which is identified as high/medium sensitivity	No	Edge of cluster of homes forming Mitchel Troy Common	None	Kymin Primary 5.1 miles; Monmouth Comp - 3.4 miles	3.4 miles	2.8 miles to Monmouth Town Centre	Daily frequency bus service available.						
Llanvair Road Open Space, Caerwent, Caldicot, NP26 5NY	Public Open Space	0.33 acres	1356 sqm	No	Adjoining	Greenfield	Residential to south and east. MOD fields to north and west. Backland development with residential properties abutting the site.	No	Potentially Green Belt	No	No	Not reviewed/no change	No	Yes	Caerwent ASA, SAM Caerwent Roman Town within 200m	No	No	None	Sensitivity not specified in Updated Landscape Study.	No	Residential area, adjacent to MOD, within 150m of A48	None	Castle Park Primary - 2.7 miles; Caldicot Comp - 3.7 miles	3.2 miles	Approx 3 miles to Caldicot Town Centre	Low frequency bus service available						
Manson Heol Amenity Land, Monmouth, NP25 9DQ	Public Open Space	0.19 acres	775 sqm	No	No	Greenfield	Row of residential properties to south, fields/c/s to all other boundaries.	No	No	River Wye Catchment	No	Not reviewed/no change	No	No	Listed buildings within 300m.	No	No	Cross Wood SINC within 500m.	LLCA M05 - High/medium sensitivity to residential development	No	Outside Monmouth development boundary; 250m to A466	Contaminated land point in northern part of site.	Osbaston Primary 1.3 miles; Monmouth Comp - 1.7 miles	1.5 miles	Approx 1.8 miles to Monmouth Town Centre	Bus services to/from Monmouth.						
Oak Grove Open Space, Rockfield, Monmouth, NP25 5PY	Public Open Space	0.74 acres	3003 sqm	No	No	Greenfield	Residential to north and east, open space/c/s to south and west.	No	No	River Wye Catchment	No	Not reviewed/no change	Yes	No	Within Rockfield CA. Historic park and garden within 500m. Listed buildings within close proximity.	No	No	River Monnow and Black Wood SINC within 100m	Sensitivity not specified in Updated Landscape Study	No	Adjacent to residential properties	None	Overmonnow Primary - 1.8 miles; Monmouth Comp - 3.1 miles	2.4 miles	Approx 2.4 miles to Monmouth Town Centre	Infrequent bus services from Rockfield.	Topography unclear					
Poorscript Lane Amenity Land, Grosmont, Abergavenny, NP7 8LP	Public Open Space	0.13 acres	528 sqm	No	Yes	Greenfield	Residential to east and west. Fields to north and west.	No	No	River Wye Catchment	No	Not reviewed/no change	Yes	Yes	Within 50m of Grosmont Conservation Area; within 200m of Grosmont Castle SAM; within Grosmont ASA; Listed Buildings approx 200m	No	No	Within 500m of River Monnow SINC	Within Grosmont Main Village	No	Within Grosmont Village Boundary, adjacent to housing allocation SAH11(v)	None	Cross Ash Primary - School - 3.5 miles; King Henry VIII Comp - 10.5 miles	3.6 miles	Approx 11 miles to Abergavenny Town Centre	Grass Routes bus service available	Unclear					
Rocklea Open Space, Mitchell Troy, Monmouth, NP25 4JE	Public Open Space	0.74 acres	3035 sqm	Surface Water Zone 2 & 3 around the edge of the site.	No	Greenfield	Residential to south	Wye Valley AONB	No	River Wye Catchment	No	Not reviewed/no change	No	No	None	No	No	SINC within 500m	Partially within MT03 LLCA - High/medium sensitivity	No	Edge of cluster of homes forming Mitchel Troy Common	None	Overmonnow Primary - 3 miles; Monmouth Comp - 3.5 miles	3.3 miles	Approx 3 miles to Monmouth Town Centre	Daily frequency bus service available.						
Sarno Square (170705 sq m) Open Space, Abergavenny, NP7 5JT	Public Open Space	42 acres	16,967 sqm	No	Yes	Greenfield	Residential to east, south and west. Open space/woodland to north.	No	No	River Usk Catchment Area	No	Not reviewed/no change	Yes	No	Close proximity to several Listed buildings; within Abergavenny Pen-y-Fal Conservation Area	No	Yes	TPOs on site, potentially SINC on part	Within development boundary of Abergavenny	No	Within 200m from A465 and railway line	Contaminated land poly (hospitals - housing with gardens)	Deri View Primary School - 1.5 miles; King Henry Comp 1.4 miles	0.5 miles	Approx 1 mile to Abergavenny Town Centre	Low and daily bus services available. Abergavenny train station and service available.						
Troy Gardens Open Space, Monmouth, NP25 5DB	Public Open Space	0.16 acres	655 sqm	No	Yes	Greenfield	Residential to west. Fields to north, east and south.	No	No	River Wye Catchment Area	No	Not reviewed/no change	No	No	None	No	No	Adjoining a SINC - Troy Station, within 200m from AONB boundary	Partially within settlement boundary and partially within LLCA M11 - High sensitivity to residential development	No	Residential area, within 200m of A40	Contaminated Land Poly - Railway Land	Overmonnow Primary - 1.1 miles; Monmouth Comp - 2 miles	0.7 miles	Approx 1 mile to Monmouth Town Centre	Daily frequency bus service available.					Play area on part of site?	
1.85 acres at Dancing Hill, Caled Llawr, Dancing Hill, Undy, CALDICOT, NP26 3BY	Agricultural, Bare Land	1.85 acres	7486 sqm	No	Adjoining	Greenfield	Residential to south, M4 to north.	No	No	No	DES2 Amenity Land	Should not be designated DES2.	No	No	No	No	Yes	TPO on northern boundary; within 100m from SINC	Within MA05 LLCA - medium sensitivity to residential development	Mineral Safeguarding Area	Whole site within 150m of M4, closest part of site within 40m of M4	EA Historic Landfill. Contaminated Landfill	Magor CIW Primary School - 0.6 miles; Caldicot Comp - 4.3 miles	0.6 miles	Approx 0.4 miles to Magor Village Centre	Low frequency bus service available. Train station and service available at Severn Tunnel Junction						
12 acres of South of Trelleck, Trelleck, Monmouth, NP25 4PF	Agricultural, Bare Land	12 acres	48,562 sqm	Flood Zone 3 Rivers on edge of site but boundary could exclude	No	Greenfield	Two residential properties surrounded by site. Fields/c/s to all other boundaries.	Wye Valley AONB	No	River Usk Catchment	No	Should not be designated DES2.	Yes	No	Trelleck Conservation Area adjacent to site; Scheduled Ancient Monuments within 350 m; Listed Buildings near by	No	Yes	SINC on part of site	TRO1 LLCA - High sensitivity	No	Rural setting	None	Trelleck Primary - 0.6 miles; Monmouth Comp - 6.5 miles	0.6 miles	Approx 6 miles to Monmouth Town Centre	Daily frequency bus service available						
7.27 acres at Dancing Hill , Magor, CALDICOT	Agricultural, Bare Land	7.27 acres	29,420 sqm	Western boundary in Zones 2 & 3 Sea and Zone 2 River but boundary could be amended to exclude	Adjoining	Greenfield	Residential to south, M4 to north.	No	No	No	DES2 Amenity Land	Should not be designated DES2.	No	No	No	No	Yes	SINC	Within MA05 LLCA - medium sensitivity to residential development	Mineral Safeguarding Area	Whole site within 150m of M4, closest part of site within 40m of M4	Contaminated Land Line running through part of site	Undy Primary School - 0.8 miles; Caldicot Comp - 4.3 miles	0.6 miles	Approx 0.4 miles to Magor Village Centre	Low frequency bus service available. Train station and service available at Severn Tunnel Junction						
0.81 acres at Dancing Hill , Undy, Magor	Agricultural, Grazing	0.81 acres	3277 sqm	No	Adjoining	Greenfield	Residential to south, M4 to north.	No	No	No	DES2 Amenity Land	Should not be DES2	No	No	No	No	No	Within 200m from SINC	Within MA05 LLCA - medium sensitivity to residential development	Mineral Safeguarding Area	Whole site within 150m of M4, closest part of site within 70m of M4	None	Undy Primary School - 0.8 miles; Caldicot Comp - 4.3 miles	0.6 miles	Approx 0.4 miles to Magor Village Centre	Low frequency bus service available. Train station and service available at Severn Tunnel Junction						
5.79 acres at rear of Langley Close , Magor	Agricultural, Grazing	5.79 acres	23,431 sqm	No	Adjoining	Greenfield	Residential to south, M4 to north.	No	No	No	DES2 Amenity Land	Should not be DES2	No	No	Within 200m from a Listed Building	No	No	Within 200m from SINC on eastern boundary.	Within MA05 LLCA - medium sensitivity to residential development	Mineral Safeguarding Area	Whole site within 150m of M4, closest part of site within 40m of M4	None	Magor CIW Primary - 1.3 miles; Caldicot Comp - 5 miles	0.4 miles	Approx 1.2 miles to Magor Village Centre	Low frequency bus service available. Train station and service available at Severn Tunnel Junction.					M4 Safeguarding route	

Site Name and Address	Description on Asset Register	Area	Larger than 500sqm?	Inside Flood Zone (NRW Development Advice Maps)	Within or adjoining a Settlement boundary (as defined in adopted LDP)	Greenfield / brownfield (as defined by Planning Policy Wales)	Surrounded by built development / privacy or amenity issues	Within BBNP or AONB	Within Green Wedge (as identified in adopted LDP) or within potential Green Belt	Within Phosphates Catchment Area	DES2 Allocation (as designated in adopted LDP)	DES2 in Review Recommendation	Within/adjacent to Conservation Area or Historic Park & Garden	Within Area of Archaeological Sensitivity	Heritage designations (LB, Con Area, Historic Park & Garden and SAMs) (state if within and what the designation is, state what is within 500 metres of the site)	Ecology Local Designations (SINC, Local Nature Reserves, TPO)	Ecology National Designations (state if within SSSI or SAC or RAMSAR or National Nature Reserve, note if within 500 metres of one of these designations)	Landscape sensitivity (state classification on Landscape Sensitivity Study)	Mineral safeguarding (state if within current safeguarding area identified in Adopted LDP)	Proximity to 'bad neighbours' (distance from dual carriageway road, trunk road, motorway, railway, industrial estate)	Contamination (state if within remediation) (state from MonMaps)	School proximity (state distance to catchment primary and secondary schools)	Medical facility proximity (state distance to nearest GP surgery)	Proximity to other amenities (e.g. shops) (state distance to nearest Main Town, Severnside Settlement or Rural secondary Settlement as identified in Sustainable Settlements RLDP Paper)	Public transport proximity and frequency (as set out in SSA) - Medium frequency - service between 10 - 30 minutes; Low frequency service between 31 - 60 minutes; Daily frequency - less than hourly (at least one in the morning and one in the afternoon)	Constrained by topography	Vehicular Access (site specific checks later)	Ability to provide utility infrastructure (complete later)	Permanency (21 years+ later)	Scope for future expansion (if needed later)	Considerations following officer site visit - should site progress for further consideration?	
Lawrence Crescent Play area, Caerwent, Caldicot, NP26 5NS	Public Open Space	0.55 acres	2225sqm	No	Part within, part adjoining	Greenfield	Residential development to south and west. Countryside to north and east. Equipped play area on eastern half.	No	Potentially Green Belt	No	50% DES2 Amenity and situated outside the development boundary. Children's Play Area on portion of site.	Potentially delete 100% of site as DES2.	No	Yes	Listed Buildings within 300m. Scheduled Ancient Monument within 350m.	Within 100m of SINC and TPO woodland.	No	Half the site within the development boundary and half outside. Landscape Sensitivity Study treats whole site as within settlement boundary.	No	Edge of residential area; Caerwent MOD site within 300m.	None	Rogiet Primary 3.6 miles; Chepstow Comp 5.7 miles	3.5 miles	Approx. 3 miles to Caldicot Town Centre	Low frequency and daily frequency bus services available. Train station with frequent services at Caldicot and Severn Tunnel Junction.	Flat site	Access off Lawrence Crescent			via	In accordance with siting criteria equipped play area has been removed. This leaves a patch of land sandwiched between residential property and a children's play area raising amenity and privacy issues. The site should therefore be removed from the process.	
Strongbow Road Play Area, Chepstow	Public Open Space	2.1 acres	8498sqm	No	Within	Greenfield	Allotments and woodland to east of site. Residential to south and west.	No	No	No	DES2 Amenity land	Potentially retain DES2 designation.	No	No	Listed Building within 450m. Scheduled Ancient Monument within 350m.	Within 100m of group TPO within 150m of SINC	No	Within development boundary of Chepstow	No	Residential area, train line within 200m	None	Pembroke Primary - 0.2 miles; Chepstow Comprehensive - 1.1 miles	0.6 miles	Approx. 150m to Bulwark Neighbourhood Shopping Centre	Low frequency and daily bus services available. Train station with frequent services available at Chepstow.	Sloping	Access off Strongbow Road between two properties.			via	Informal open space of high value. Access via a narrow road between two houses. Site should be removed from the process.	
Caerwent Lane (3615 sq m) Public Open Space, Chepstow, NP16 5TQ	Public Open Space	0.89 acres	3801sqm	Zone 3 Surface Water on most of site	Within	Greenfield	Residential to north and east. M48 to south and Beaufort Park employment site to west.	No	No	No	No	Not reviewed / no change expected	No	No	Scheduled Ancient Monument within 120m	No	River Wye SSSI and SAC 500m away	Within development boundary of Chepstow	No	Opposite Beaufort Park Employment site; adjacent to M48. Residential area to north and east of site	Contaminated Land Line running across southern section of site	Thornwell Primary - 0.4 miles; Chepstow Comp - 2.7 miles	2.3 miles	Approx 150m to Thornwell Neighbourhood Shopping Centre	Low frequency and daily bus services available. Train station with frequent services available at Chepstow.	Site slopes into the centre of the site	Access off Caerwent Lane			via	Topography not appropriate with significant changes in levels across the site, with water water course running through. Site should be removed from the process. Potential ecological value.	
Lancaster Way Public Open Space, Osbaston, Monmouth, NP25 3BE	Public Open Space	1.22 acres	4943 sqm	Zone 3 Surface Water running along northern boundary	Adjoining	Greenfield	Residential to east and west. Fields to north and west.	No	No	Upper River Wye Catchment	DES2 Amenity land	Potentially retain as DES2.	No	No	None	No	No	Within LLCA M05 - High/medium sensitivity to residential development	No	Edge of residential area and countryside	None	Osbaston CW Primary - 0.2 miles; Monmouth Comp - 1.2 miles	1.1 miles	Approx. 1 mile to Monmouth Town Centre	Daily frequency bus service available.	Part of site slopes steeply to the west towards a stream	Access off Lancaster Way			via	Informal open space of value. Topography not appropriate. Site should be removed from the process.	
Orchid Drive Open Space, Caldicot, NP26 5GE	Public Open Space	3.4 acres	14,500 sqm - western half 6,600 sqm; eastern half 7,900 sqm	No	Adjoining	Greenfield	Residential to north, east and west. Railway line and Gwent Levels to south.	No	No	No	DES2 Amenity land. Children's Play Area on part of site.	Potentially retain as DES2 with boundary amendments to exclude houses and road.	No	No	Scheduled Ancient Monument within 500m	Western half of site is a SINC	Within 200m of SSSI and within 300m of RAMSAR sites and SAC	Treated as within the development boundary for the Landscape Sensitivity Study; adjoins LLCA CA05 - high/medium sensitivity to housing	No	10m from mainline railway to south; Severn Bridge Employment site adjoining western boundary	Contaminated Land Poly on western half of site	Durand Primary - 0.8 miles; Caldicot Comp - 0.8 miles	1.2 miles	Approx. 0.5 miles to Caldicot Town Centre	Low frequency and daily frequency bus services available. Train station with frequent services at Caldicot and Severn Tunnel Junction.	Flat site	Access off Orchard Drive			via	Site is made up of two distinct parcels of land - western half is a community garden and unimproved nature area. DES2 amenity land and SINC. Eastern half is a maintained open space with equipped play provision on part of the site and industrial area immediately to the east. Site should be removed from the process.	
Blethyn Close Open Space, Shirenewton, NP16 6SW	Public Open Space	3.57 acres	14466 sqm	No	Adjoining	Greenfield	Residential to north and east. Fields/countryside to south and west.	No	Within existing Green Wedge, potentially Green Belt	No	DES2 Amenity Land	Potentially retain as DES2	No	No	None	SINC to immediate south & west. TPO trees on western boundary.	The site is located less than 250m from the Mynglodda Myrnydd Bach SSSI which is an important hibernation roost for lesser horseshoe bats.	Sensitivity not specified in Updated Landscape Study.	No	Edge of residential area and countryside	None	Shirenewton Primary - 0.3 miles; Chepstow Comp - 3.5 miles	4 miles	Approx. 3 miles to Chepstow Town Centre	Daily frequency bus service available.	Relatively flat site	Access off Blethyn Close. Section immediately alongside site is unadopted.				Some scope for future expansion depending on number of pitches initially provided and consideration of maximum desirable size limit.	Informal open space of value but no other significant constraints. Site should progress to the next stage of the process for further consideration.
Brookside Open Space, Neddern Way, Caldicot, NP26 4NJ	Public Open Space	3.59 acres	14530 sqm	No	Adjoining	Greenfield	Residential to east, south and west. Woodland/buffer and M48 to north.	No	No	No	DES2 Amenity Land	Potentially delete part of the DES2 designation (Sandy Lane 8).	No	No	Within 400m of Scheduled Ancient Monument	Within 300m of SINC	Within 500m of Neddern Wetland SSSI	LLCA CA03 - High/medium sensitivity to residential development	No	M48 within 50m	None	Castle Park Primary - 0.4 miles; Caldicot Comp - 1.2 miles	1.2 miles	Approx. 1.3 miles to Caldicot Town Centre	Low frequency and daily frequency bus services available. Train station with frequent services at Caldicot and Severn Tunnel Junction.	Flat site	No obvious vehicular access to the site			Some scope for future expansion depending on number of pitches initially provided and consideration of maximum desirable size limit.	Informal open space of value and no obvious vehicular access to the site. Site should progress to the next stage of the process for further consideration.	
Crossen Parc Public Open Space, Abergavenny, NP7 6PF	Public Open Space	1.95 acres	7891 sqm	Small area of zone 3 surface water	Adjoining	Greenfield	Residential to west. Open space/woodland to other boundaries.	No	No	Upper River Usk Catchment	No	Potentially designate as DES2.	No	No	None	SINC immediately adjacent. Group TPO to eastern boundary.	Cwm Mill SSSI within 500m	LLCA A01 - High/medium sensitivity to residential development	No	A465 and railway line within 300m. Allocated employment site within 300m.	Contaminated land poly on adjacent land	Den View Primary - 0.8 miles; King Henry VIII Comp - 1.1 miles (moving to King Henry VIII 3-19 - 1.1 miles)	0.8 miles	Approx. 0.3 miles to Rother Avenue Neighbourhood Centre; 0.7 miles to Abergavenny Town Centre	Low frequency and daily frequency bus services available. Train station with frequent services within Abergavenny.	Flat site, steeply sloping wooded edge but this would not be developed	Access of residential cul-de-sac			No scope for future expansion	Flat site with good access. Informal open space of value but no other significant constraints. Site should progress to the next stage of the process for further consideration.	
Garth Close Open Space, Mitchell Troy, NP25 4JN	Public Open Space	1.56 acres	6318 sqm	No	Not adjoining settlement as defined in adopted LDP	Greenfield	Residential to north, east and south. Fields to west.	Within Wye Valley ACNB	No	Upper River Wye Catchment	No	Not reviewed / no change likely	No	No	Listed building within 500m	SINCs within 200m	No	Adjacent to LCA MT01 which is identified as high/medium sensitivity	No	Edge of cluster of homes forming Mitchell Troy Common	None	Kymin Primary 5.1 miles; secondary Monmouth - 3.4 miles	3.4 miles	Approx. 2.8 miles to Monmouth Town Centre	Daily frequency bus service available.	Site slopes from north to south	Existing field access.			Some scope for future expansion depending on number of pitches initially provided and consideration of maximum desirable size limit.	Site should progress to the next stage of the process for further consideration.	
Llanvair Road Open Space, Caerwent, Caldicot, NP26 5NY	Public Open Space	0.33 acres	1356 sqm	No	Adjoining	Greenfield	Residential to south and east. MOD fields to north and west. Very constrained site due to size and shape. Backland development with residential properties abutting the site.	No	Potentially Green Belt	No	No	Not reviewed / no change likely	No	Yes	SAM Caerwent Roman Town within 200m	No	No	Sensitivity not specified in Updated Landscape Study.	No	Residential area; adjacent to MOD; within 150m of A48	None	Castle Park Primary - 2.7 miles; Caldicot Comp - 3.7 miles	3.2 miles	Approx 3 miles to Caldicot Town Centre	Low frequency and daily frequency bus services available. Train station with frequent services at Caldicot and Severn Tunnel Junction.	Flat site	Access off Llanvair Road but constrained at northern end of site, requiring a right turn onto the main part of the site.			via	Inadequate access and site is an awkward shape. Development would represent a form of backland development causing amenity/privacy issues for future tenants and occupiers of immediately adjoining properties. The site should be removed from the process.	
Manson Heights Amenity Land, Monmouth, NP25 5QX	Public Open Space	0.19 acres	775 sqm	No	Not adjoining settlement as defined in adopted LDP	Greenfield	Row of residential properties to south, fields/countryside to all other boundaries.	No	No	Upper River Wye Catchment	No	Not reviewed / no change likely	No	No	Listed buildings within 300m.	Cross Wood SINC within 350m.	No	LLCA M05 - High/medium sensitivity to residential development	No	Outside Monmouth development boundary; 250m to A466	Contaminated land point in northern part of site.	Osbaston Primary 1.3 miles; Secondary Monmouth - 1.7 miles	1.5 miles	Approx 1.8 miles to Monmouth Town Centre	Low frequency bus service available	Flat site	Access is via a single track from the A466.			No scope for future expansion	Access arrangement raise concerns. Site should progress to the next stage for further consideration.	
Rocklea Open Space, Mitchell Troy, NP25 4JE	Public Open Space	0.74 acres	3035 sqm	No	Not adjoining settlement as defined in adopted LDP	Greenfield	Residential to south	Within Wye Valley ACNB	No	Upper River Wye Catchment	No	Not reviewed / no change likely	No	No	None	SINCs within 500m	No	Adjacent to Mitchell Troy Common - no settlement status within adopted LDP. Partially within MTO3 LLCA which is identified as high/medium sensitivity.	No	Edge of cluster of homes forming Mitchell Troy Common	None	Overmonnow Primary - 3 miles; secondary Monmouth - 3.5 miles	3.3 miles	Approx 3 miles to Monmouth Town Centre	Daily frequency bus service available.	Flat site but elevated above road	No existing vehicular access but potential for new access off Common Road. NB levels difference between road and site.			Some scope for future expansion depending on number of pitches initially provided and consideration of maximum desirable size limit.	No vehicular access identified but potential for new access off Common Road should be explored. Site should progress to next stage. For further consideration.	

Troy Gardens Open Space, Mornmouth, NP25 5DB	Public Open Space	0.16 acres	655 sqm	No	Adjoining	Greenfield	Residential to west. Fields to north, east and south.	Within 200m of ACNB	No	Upper River Wye Catchment	No	Not reviewed / no change likely	No	None	None	Adjoining a SNC (S051 - Neutral Grassland, Calcareous Grassland, Post-Industrial Land), TPO tree near northern boundary	No	Partially within settlement boundary and partially within LLCA M11 - High sensitivity to residential development	Residential area, within 200m of A40	Contaminated Land Poly - Railway Land	Oversomrow Primary - 1.1 miles, Mornmouth Comp - 2 miles	0.7 miles	Approx 1 mile to Mornmouth Town Centre	Daily frequency bus service available.	Flat site	Access from Troy Gardens			Site	Equipped Play Area on site. Siting criteria removes such sites from the process. The remaining site is below the minimum required 500 sqm site area. The site should be removed from the process.
Land west of Grange Road, Dancing Hill (Caled Lawr, Dancing Hill, Magor with Undy, CALDICOT, NP26 3BY) (1.85 acres)	Agricultural, Bare Land	1.85 acres	7486 sqm	No	Adjoining	Greenfield	Residential to south and east (on opposite side of road), M4 to north.	No	No	No	Moisty DES2 Amenity Land	Likely to delete DES2 designation as not publicly accessible	No	None	None	Group TPO to northwest of site, adjacent to SNC (W neutral grassland)	No	Within MA05 LLCA - medium sensitivity to residential development	Mineral Safeguarding Area	Whole site within 150m of M4, closest part of site within 40m of M4	EA Historic Landfill Contaminated Landfill	Magor CW Primary School - 0.6 miles, Undy Primary School - 0.8 miles, secondary Caldicot - 4.3 miles	0.6 miles	Approx 0.4 miles to Magor Village Centre	Low frequency and daily frequency bus services available. Train station with frequent services at Caldicot and Severn Tunnel Junction.	Flat site	Access would be through the adjoining Dancing Hill site (1.85 acres) or new access off Dancing Hill/Grange Road		Some scope for future expansion depending on number of pitches initially provided and consideration of maximum desirable size limit.	Site should progress to next stage of assessment process.
Land west of Grange Road, Dancing Hill, Magor with Undy, CALDICOT NP26 3BY (7.27 acres)	Agricultural, Bare Land	7.27 acres	29,420 sqm	Western edge in Zones 2 & 3 Sea and Zone 2 River due to Mill Brook but site boundary could be amended to exclude this area	Adjoining	Greenfield	Residential to south and east (on opposite side of road), M4 to north.	No	No	No	Moisty DES2 Amenity Land	Likely to delete DES2 designation as not publicly accessible	No	None	None	Western part of site is a SNC (H4 neutral grassland), Group TPO to east of site.	No	Within MA05 LLCA - medium sensitivity to residential development	Mineral Safeguarding Area	Whole site within 150m of M4, closest part of site within 40m of M4	Contaminated Land Line running through part of site	Magor CW Primary School - 0.6 miles, Undy Primary School - 0.8 miles, secondary Caldicot - 4.3 miles	0.6 miles	Approx 0.4 miles to Magor Village Centre	Low frequency and daily frequency bus services available. Train station with frequent services at Caldicot and Severn Tunnel Junction.	Site slopes from east to west.	Access off Grange Road		Site is much larger than needed. Scope to expand in the future if needed subject to consideration of maximum desirable size limit.	Site has a number of constraints including flood risk on part of the site, access issues and part is a designated SNC. Site should progress to the next stage with the exclusion of the western half covered by SNC and flood risk. Combine northern strip of land with Dancing Hill (1.85 acres) site to form one site.
Land east of Grange Road, Dancing Hill, Magor with Undy CALDICOT, NP26 3BY (0.81 acres)	Agricultural, Grazing	0.81 acres	3277 sqm	No	Adjoining	Greenfield	Residential to north and south, M4 further to north.	No	No	No	DES2 Amenity Land	Likely to delete DES2 designation as not publicly accessible	No	None	None	Within 200m from SNC	No	Within MA05 LLCA - medium sensitivity to residential development	Mineral Safeguarding Area	Whole site within 150m of M4, closest part of site within 70m of M4	No	Magor CW Primary School - 0.6 miles, Undy Primary School - 0.8 miles, secondary Caldicot - 4.3 miles	0.6 miles	Approx 0.4 miles to Magor Village Centre	Low frequency and daily frequency bus services available. Train station with frequent services at Caldicot and Severn Tunnel Junction.	Flat site	Access off Grange Road		No scope for future expansion in isolation, but scope if considered alongside the adjacent Dancing Hill site	Site should progress to the next stage of the process for further consideration.
Land at rear of Langley Close, Magor with Undy	Agricultural, Grazing	5.79 acres	23,431 sqm	No	Adjoining	Greenfield	Residential to south and east (on opposite side of road), M4 to north.	No	No	No	0.1ha of site DES2 on western boundary.	Likely to delete DES2 designation as not publicly accessible	No	None	Listed building within 200m of western end of site - site could be reduced in size to avoid impact	Within 200m of SNC (H4 neutral grassland), 2x TPO trees on/over southern boundary	No	Within MA05 LLCA - medium sensitivity to residential development	Mineral Safeguarding Area	Whole site within 150m of M4, closest part of site within 40m of M4	No	Magor CW Primary - 1.3 miles, secondary Caldicot - 5 miles	0.4 miles	Approx 1.2 miles to Magor Village Centre	Low frequency and daily frequency bus services available. Train station with frequent services at Caldicot and Severn Tunnel Junction.	Flat site	Access off St Bride's Road		Site is much larger than needed. Scope to expand in the future if needed and still leave a buffer to the listed Building, but subject to consideration of maximum desirable size limit.	Site should progress to the next stage of the process for further consideration.

Site Name and Address	Description on Asset Register	Area	Larger than 50sqm?	Inside Flood Zone (NRW Developments & Advice Maps)	Within or adjoining a settlement boundary (as defined in adopted LDP)	Greenfield (as defined by Planning Policy Wales)	Surrounded by built development / privacy or amenity issues	Within BBNP or AONB	Within Green Wedge (as identified in adopted LDP)	Within Phosphates Catchment Area	DES2 Allocation (as designated in adopted LDP)	DES2 in Review Recommendation	Within/Adjacent to Conservation Area or Historic Park & Garden	Within Area of Archaeological Sensitivity	Heritage designations (S.B. Con Area, Historic Park & Garden and DMA) (state if within and what the designation is, state what is within 500 metres of the site)	Ecology Local Designations (SINC, Local Nature Reserves, TPO)	Ecology National Designations (SSSI or SAC or RAMSAR or National Nature Reserve, note if within 500 metres)	Landscape sensitivity (state classification on Landscape Sensitivity Study)	Mineral Safeguarding (state if within current safeguarding area identified in Adopted LDP)	Proximity to 'bad neighbours' (distance from dual carriageway road, railway, industrial estate)	Contamination (viability of remediation) (state from MonMaps)	School proximity (state distance to nearest primary and secondary schools)	Medical facility proximity (state distance to nearest GP surgery)	Proximity to other amenities (e.g. shops) (state distance to nearest Main Town, Services Settlement or Rural Secondary Settlement as identified in Sustainable Settlements RLP Paper)	Public transport proximity and frequency (as set out in SSA) - (state frequency of service between 10-30 minutes; Low frequency service between 31-60 minutes; Daily frequency - less than hourly (at least one in the morning and one in the afternoon))	Constrained by topography	Vehicle Access (state specific checks later)	Ability to provide utility infrastructure (complete later)	Permanency (21 years) (state)	Scope for future expansion if needed	Considerations following officer site visit - should site progress for further consideration?	Highways Comments	Active Travel Comments	ENH/Protection Comments	Floods/SUDs Comments	GI Comments	Ecology Comments	ALC predicted grade
Blethyn Close Open Space, Shrewnston, NP16 6DW	Public Open Space	3.57 acres	1446 sqm	No	Adjoining	Greenfield	Residential to north and east. Fields/countryside to south and west.	No	Within existing Green Wedge potential Green Belt	No	DES2 Adversely Land	Potentially delete part of the DES2 designation (Sandy Lane B)	No	No	None	SINC to immediate south & west. TPO tree on western boundary.	The site is located less than 250m from the Mynydd Bach SSSI which is an important Nattergalion roost for lesser horseshoe bats.	Sensitivity not specified in Updated Landscape Study.	No	Edge of residential area and countryside	None	Shrewnston Primary - 0.3 miles; Chepstow Comp - 3.6 miles	1.4 miles	Approx. 3 miles to Chepstow Town Centre	Daily frequency bus service available.	Relatively flat site	Access of Blethyn Close Section immediately alongside site is unobstructed.	No	Some scope for future expansion depending on number of pitches initially provided and consideration of maximum desirable size limit.	Informal open space of value but no other significant constraints. Site should progress to the next stage of the process for further consideration.	Proposed for up to 28 pitches. Above Route C17.18 (Blethyn Close) and Route C11.11 (Chepstow Hill) are a residential street. Due to the size, scale, and type of development the traffic impact is considered to be minimal to the site. The adjacent local residential network in particular Route C17.11 (Chepstow Hill) is not capable of accommodating the numbers, type and size of vehicles associated with the proposed development. Site is poorly located in an undesirable location about the local Primary school is within 350 metres. Poor sustainable transport site.	Outside of locally sensitive area. Near A70M route - MCC-033A	No former development of the land. No objection.	No known issues. Four sewer crossing are well managed as per DES2. It is a designated green residential street. Due to the size, scale, and type of development the traffic impact is considered to be minimal to the site. The adjacent local residential network in particular Route C17.11 (Chepstow Hill) is not capable of accommodating the numbers, type and size of vehicles associated with the proposed development. Site is poorly located in an undesirable location about the local Primary school is within 350 metres. Poor sustainable transport site.	Based on the location, impact on sewer crossing are well managed as per DES2. It is a designated green residential street. Due to the size, scale, and type of development the traffic impact is considered to be minimal to the site. The adjacent local residential network in particular Route C17.11 (Chepstow Hill) is not capable of accommodating the numbers, type and size of vehicles associated with the proposed development. Site is poorly located in an undesirable location about the local Primary school is within 350 metres. Poor sustainable transport site.	The site is adjacent to Shrewnston Meadows SINC and located in an area of high quality ecological features. Proximity to high quality ecological features makes the site unsuitable for the proposed development.	2	
Brookside Open Space, Nodden Way, Caldicot, NP26 6NJ	Public Open Space	3.59 acres	1423 sqm	No	Adjoining	Greenfield	Residential to east, south and west. Woodland/buffer and M48 to north.	No	No	No	DES2 Adversely Land	Potentially delete part of the DES2 designation (Sandy Lane B)	No	No	Within 400m of Scheduled Ancient Monument	Within 300m of SINC	Within 500m of Nodden Wetland SSSI	LLCA LAD3 - High/medium sensitivity to residential development	Mineral Safeguarding (state if within current safeguarding area identified in Adopted LDP)	M48 within 50m	None	Caldicot Primary - 0.4 miles; Caldicot Comp - 1.2 miles	1.2 miles	Approx. 1.3 miles to Caldicot Town Centre	Low frequency and daily frequency bus services available. Train station with frequent services at Caldicot and Severn Tunnel Junction.	Flat site	No existing vehicular access to the site.	No	Some scope for future expansion depending on number of pitches initially provided and consideration of maximum desirable size limit.	Informal open space of value and no obvious vehicular access to the site. Site should progress to the next stage of the process for further consideration.	Proposed for up to 28 pitches. No current vehicular access to the site. Scale, and type of development the impact of the development is considered to be minimal to the site. The adjacent local residential network in particular Route C17.11 (Chepstow Hill) is not capable of accommodating the numbers, type and size of vehicles associated with the proposed development. Site is poorly located in an undesirable location about the local Primary school is within 350 metres. Poor sustainable transport site.	Designated locally. Caldicot On route MCC-033B. National Cycle Network route runs through site.	No former development of the land. No objection.	No known issues. DCWW mains and sewer crossing are well managed as per DES2. It is a designated green residential street. Due to the size, scale, and type of development the traffic impact is considered to be minimal to the site. The adjacent local residential network in particular Route C17.11 (Chepstow Hill) is not capable of accommodating the numbers, type and size of vehicles associated with the proposed development. Site is poorly located in an undesirable location about the local Primary school is within 350 metres. Poor sustainable transport site.	Flat site with good access. Informal open space of value but no other significant constraints. Site should progress to the next stage of the process for further consideration.	The site comprises grassland which is being managed as part of the Nature Park. The site is located less than 250m from the Mynydd Bach SSSI which is an important Nattergalion roost for lesser horseshoe bats. Proximity to high quality ecological features makes the site unsuitable for the proposed development.	3b	
Croswen Parc Public Open Space, Abergavenny, NP7 6PF	Public Open Space	1.86 acres	7891 sqm	Small area of surface water	Adjoining	Greenfield	Residential to west. Open space/woodland to other boundaries.	No	No	Upper River Wye Catchment	No	Potentially delete part of the DES2 designation (Sandy Lane B)	No	No	None	SINC immediately adjacent. Group TPO to eastern boundary.	Cwm M1 SSSI within 500m	LLCA AD1 - High/medium sensitivity to residential development	No	M48 and railway line within 300m. Allocated employment site within 300m.	Contaminated land point on adjacent land	Dist. View Primary - 0.8 miles; King Henry VIII Comp - 1.1 miles (existing to King Henry V8 3-11 - 1.3 miles)	0.8 miles	Approx. 0.3 miles to Rother Avenue Neighbourhood Centre, 0.7 miles to Abergavenny Town Centre	Low frequency and daily frequency bus services available. Train station with frequent services at Abergavenny.	Flat site, steeply sloping wooded edge but this would not be developed	Access of residential cul-de-sac	No	Some scope for future expansion depending on number of pitches initially provided and consideration of maximum desirable size limit.	Flat site with good access. Informal open space of value but no other significant constraints. Site should progress to the next stage of the process for further consideration.	Proposed for up to 15 pitches. Well located and accessible. Former sewage works (1977) near site. Increase in traffic can be accommodated with little or no improvements. Sustainable location. TA would be required.	Designated locally. Nearest route MCC-A12A	No former development of the land. No objection.	No known issues. DCWW mains and sewer crossing are well managed as per DES2. It is a designated green residential street. Due to the size, scale, and type of development the traffic impact is considered to be minimal to the site. The adjacent local residential network in particular Route C17.11 (Chepstow Hill) is not capable of accommodating the numbers, type and size of vehicles associated with the proposed development. Site is poorly located in an undesirable location about the local Primary school is within 350 metres. Poor sustainable transport site.	The site comprises grassland which is being managed as part of the Nature Park. The site is located less than 250m from the Mynydd Bach SSSI which is an important Nattergalion roost for lesser horseshoe bats. Proximity to high quality ecological features makes the site unsuitable for the proposed development.	3b		
Garth Close Open Space, Mitchell Tro, NP25 4JN	Public Open Space	1.56 acres	6318 sqm	No	Not adjoining settlement as defined in adopted LDP	Greenfield	Residential to north, east and south. Fields to west.	No	Within Wye Valley AONB	Upper River Wye Catchment	No	Not reviewed / no change likely	No	No	Listed building within 500m	SINCs within 200m	No	Adjacent to LCA M101 which is identified as high/medium sensitivity	No	Edge of cluster of homes facing Mitchell Troy Common	None	Kymn Primary 0.1 miles; secondary Monmouth - 3.4 miles	3.4 miles	Approx. 2.8 miles to Monmouth Town Centre	Daily frequency bus service available.	Site slopes from north to south	Existing field access off unadopted lane.	No	Some scope for future expansion depending on number of pitches initially provided and consideration of maximum desirable size limit.	Site should progress to the next stage of the process for further consideration.	Proposed for up to 15 pitches. No private drive and about Route C47.3 Common Road near Route C47.1 Common Road 500 metres from Route R48, Mitchell Troy Road to the North and 1.4 km from the B4293 Monmouth Road to the South. Due to the size, scale, and type of development the traffic impact of the development is considered negligible but off-site improvements may be needed. The existing access requires improvement to the existing shared private drive and field gate access. However, if needed a new access is achievable directly off Route C47.3 Common Road but will result in considerable loss of the existing boundary hedge.	Outside of locally sensitive area. Nearest route MCC-A12B	No former development of the land. No objection based on information available.	No known issues. DCWW mains and sewer crossing are well managed as per DES2. It is a designated green residential street. Due to the size, scale, and type of development the traffic impact is considered to be minimal to the site. The adjacent local residential network in particular Route C17.11 (Chepstow Hill) is not capable of accommodating the numbers, type and size of vehicles associated with the proposed development. Site is poorly located in an undesirable location about the local Primary school is within 350 metres. Poor sustainable transport site.	The site is an open grassland area within the open countryside. The site is located less than 250m from the Mynydd Bach SSSI which is an important Nattergalion roost for lesser horseshoe bats. Proximity to high quality ecological features makes the site unsuitable for the proposed development.	23b		
Manson Heights Amenity Land, Monmouth, NP25 6XQ	Public Open Space	0.19 acres	775 sqm	No	Not adjoining settlement as defined in adopted LDP	Greenfield	Row of residential properties to south, fields/countryside to all other boundaries.	No	No	Upper River Wye Catchment	No	Not reviewed / no change likely	No	No	Listed buildings within 300m.	Cross Wood SINC within 350m.	LLCA M05 - High/medium sensitivity to residential development	No	Outside Monmouth development boundary 250m to A466	Contaminated land point in northern part of site.	Osleston Primary 1.3 miles; Secondary Monmouth - 1.7 miles	1.5 miles	Approx. 1.8 miles to Monmouth Town Centre	Low frequency bus service available.	Flat site	Access is via a single track from the A466.	No	Some scope for future expansion depending on number of pitches initially provided and consideration of maximum desirable size limit.	Access arrangement noise concerns. Site should progress to the next stage for further consideration.	Proposed for 5 pitches. Due to the size, scale and type of development the traffic impact would be negligible. Route C518.7 and C518.8 Manson Lane although narrow single lane rural lanes are considered capable of accommodating the significant increase in vehicle movements associated with the proposed development. No objection on safety and capacity of the adjacent highway network, however, the location is not considered to be a sustainable transport location.	Outside of locally sensitive area. Nearest route MCC-A12B	No former development of the land. No objection based on information available.	No known issues. DCWW mains and sewer crossing are well managed as per DES2. It is a designated green residential street. Due to the size, scale, and type of development the traffic impact is considered to be minimal to the site. The adjacent local residential network in particular Route C17.11 (Chepstow Hill) is not capable of accommodating the numbers, type and size of vehicles associated with the proposed development. Site is poorly located in an undesirable location about the local Primary school is within 350 metres. Poor sustainable transport site.	Enclosed by mature species hedge with trees and accessed via a narrow lane with veteran / over mature oak trees. The quality of habitats is unknown without surveys but it is likely that the habitats will meet priority criteria and there is potential for priority grassland. There are no statutory designated areas within 10m. Hedgerow loss would provide access to the site. Hedgerow loss would make the site unsuitable for the proposed development.	2			
Rocklea Open Space, Mitchell Troy, NP25 4JE	Public Open Space	0.74 acres	3030 sqm	No	Not adjoining settlement as defined in adopted LDP	Greenfield	Residential to south	No	Within Wye Valley AONB	Upper River Wye Catchment	No	Not reviewed / no change likely	No	No	None	SINCs within 500m	Partially within M103 LLCA - High/medium sensitivity	No	Edge of cluster of homes facing Mitchell Troy Common	None	Ovemonnow Primary - 3 miles; secondary Monmouth - 3.5 miles	3.3 miles	Approx. 3 miles to Monmouth Town Centre	Daily frequency bus service available.	Flat site but elevated above road	No existing vehicular access but potential for new access off Common Road. NB levels difference between road and site.	No	Some scope for future expansion depending on number of pitches initially provided and consideration of maximum desirable size limit.	No vehicular access identified but potential for new access off Common Road should be explored. Site should progress to next stage. For further consideration.	Proposed for 5 pitches. Due to the size, scale and type of development the traffic impact of the development is considered negligible but off-site improvements may be needed. The existing access requires improvement to the existing shared private drive and field gate access. However, if needed a new access is achievable directly off Common Road but will result in considerable loss of the existing boundary hedge. Not considered to be a sustainable transport location.	Outside of locally sensitive area. Nearest route MCC-A12B	No former development of the land. An operational sewer works north west has no identified impact on residents of the site. May be necessary to south west would require access across multiple third party land holdings.	No known issues. DCWW mains and sewer crossing are well managed as per DES2. It is a designated green residential street. Due to the size, scale, and type of development the traffic impact is considered to be minimal to the site. The adjacent local residential network in particular Route C17.11 (Chepstow Hill) is not capable of accommodating the numbers, type and size of vehicles associated with the proposed development. Site is poorly located in an undesirable location about the local Primary school is within 350 metres. Poor sustainable transport site.	The site is bounded by mature species hedge with trees and accessed via a narrow lane with veteran / over mature oak trees. The quality of habitats is unknown without surveys but it is likely that the habitats will meet priority criteria and there is potential for priority grassland. There are no statutory designated areas within 10m. Hedgerow loss would provide access to the site. Hedgerow loss would make the site unsuitable for the proposed development.	23b			

Land west of Grange Road, Dancing Hill (amended to include northern section of land - 3.87 acres), Magor with Undy CALDICOT, NP26 5BY	Agricultural, part grazing part bare land	3.14 acres	12,726 sign	No	Adjoining	Greenfield	Residential to south and east (on opposite side of road), M4 to north.	No	No	No	Roughly 60% DES2 Amenity Land	Likely to delete DES2 designation as not publicly accessible	No	No	None	Small TPO along eastern side of site adjacent to SINC (M4 neutral grassland)	No	Within MAGS LLCA - medium sensitivity to residential development	Mineral Safeguarding Area	Whole site within 150m of M4, closest part of site within 40m of M4	EA Historic Landfill, Contaminated Landfill	Magor C/W Primary School - 0.6 miles; Undy Primary School - 0.3 miles; secondary Caldicot - 4.3 miles	0.6 miles	Approx 0.4 miles to Magor Village Centre	Low frequency and daily frequency bus services available. Train station with frequent services at Caldicot and Severn Tunnel Junction.	Relatively flat site	New access off Grange Road			Some scope for future expansion depending on number of pitches initially provided and consideration of maximum desirable size limit.	Site should progress to next stage of assessment process.	Proposed for 14 sites (1440 plots). Landfill gas monitoring works to provide forage on western side, road narrowing and priority give ways ongoing to accommodate LDP housing development. Existing field access. Grange Road can accommodate the traffic flows arising from the size and scale of the proposal but the field access location conflicts with the road narrowing works and as such the development would compromise the safe use of Grange Road and free flow of traffic calming through the one way priority narrowing. An alternative access can be provided towards the north-east corner of the site.	Designated locality: Magor and Undy. Near route MCC-S13A	Normal use of site (1440 plots). Landfill gas monitoring works to provide forage on western side, road narrowing and priority give ways ongoing to accommodate LDP housing development. Existing field access. Grange Road can accommodate the traffic flows arising from the size and scale of the proposal but the field access location conflicts with the road narrowing works and as such the development would compromise the safe use of Grange Road and free flow of traffic calming through the one way priority narrowing. An alternative access can be provided towards the north-east corner of the site.	No real flood risk. S4B approval. Nearby historic surface water flooding issues should be considered at design stage.	Northern edge of Undy. Relatively flat fields bounded by hedge to three sides and residential to south. Partly DES2 but currently grassed. Buffer to M4. Small group of TPO trees. Bounds the Grange Road SINC to the west. Part of the site is indicated as being an historic landfill site. Would need to ensure the DES2 area is still a publicly accessible area as part of the overall design. Space for tree planting to the western and eastern boundaries would limit visual impact. Overall suitable subject to an appropriate scheme.	Site comprises low-lying grassed fields with a central hedge with one veteran oak mature tree, and borders the M4 woodland corridor to the north. The site is adjacent to Grange Road SINC used for neutral grassland, and is less than 10m from Gwent Levels SSSI. The woodland along the M4 corridor is likely to support dormouse, other species that may be present include bats (including roosts in trees), reptiles and nesting birds. It is recommended that the proximity to ecological features of high quality makes the site unsuitable for the proposed development.	26
Land east of Grange Road, Dancing Hill, Magor with Undy CALDICOT, NP26 5BY (0.81 acres)	Agricultural, Grazing	0.81 acres	2077 sign	No	Adjoining	Greenfield	Residential to north and south, M4 further to north.	No	No	No	DES2 Amenity Land	Likely to delete DES2 designation as not publicly accessible	No	None	Within 200m from SINC	No	Within MAGS LLCA - medium sensitivity to residential development	Mineral Safeguarding Area	Whole site within 150m of M4, closest part of site within 70m of M4	EA Historic Landfill, Contaminated Landfill	Magor C/W Primary School - 0.6 miles; Undy Primary School - 0.3 miles; secondary Caldicot - 4.3 miles	0.6 miles	Approx 0.4 miles to Magor Village Centre	Low frequency and daily frequency bus services available. Train station with frequent services at Caldicot and Severn Tunnel Junction.	Flat site	Access off Grange Road			No scope for future expansion in isolation, but scope if considered alongside the adjacent Dancing Hill site	Site should progress to the next stage of the process for further consideration.	Proposed for 6 pitches. Access Route C279.5 Grange Road Works to provide forage on western side, road narrowing and priority give ways ongoing to accommodate LDP housing development. Existing field access. Grange Road can accommodate the traffic flows arising from the size and scale of the proposal but the field access location conflicts with the road narrowing works and as such the development would compromise the safe use of Grange Road and free flow of traffic calming through the one way priority narrowing. An alternative access is not considered achievable.	Designated locality: Magor and Undy. Near route MCC-S13A	No former use shown on historic maps but construction of the adjacent M4 could have affected this land. The site should be investigated, and if necessary remediated prior to introducing a receptor. Air quality and noise assessments are required due to proximity to the M4.	No real flood risk. S4B approval. Nearby historic surface water flooding issues should be considered at design stage.	Site located to northern edge of Undy. Relatively flat fields bounded by surface water flooding issues to south and new development under construction to east. Currently DES2 but in boundary settlement and M4. Suitable for proposed development subject to an appropriate scheme.	Site comprises low-lying grassed fields. The site is less than 200m from Grange Road SINC and less than 10m from Gwent Levels SSSI. Protected species that may be present include bats (including roosts in trees), reptiles and nesting birds. Surveys will be required to establish presence/absence of priority habitats and protected species. The layout would require appropriate buffer and protection between ecological features identified on site.	U	
Land at rear of Langrey Close, Magor with Undy	Agricultural, Grazing	5.79 acres	23,431 sign	No	Adjoining	Greenfield	Residential to south and east (on opposite side of road), M4 to north.	No	No	No	0.1% of site DES2 on eastern boundary.	Likely to delete DES2 designation as not publicly accessible	No	Listed building within 200m of western end of site - site could be reduced in size to avoid impact	Within 200m of SINC (M4 neutral grassland). 2x TPO trees on/near southern boundary	No	Within MAGS LLCA - medium sensitivity to residential development	Mineral Safeguarding Area	Whole site within 150m of M4, closest part of site within 40m of M4	EA Historic Landfill, Contaminated Landfill	Magor C/W Primary - 1.3 miles; secondary Caldicot - 5 miles	0.4 miles	Approx 1.2 miles to Magor Village Centre	Low frequency and daily frequency bus services available. Train station with frequent services at Caldicot and Severn Tunnel Junction.	Flat site	Access off St Brides Road			Site is much larger than needed. Scope to expand to the future if needed and still leave a buffer to the listed building, but subject to consideration of maximum desirable size limit.	Site should progress to the next stage of the process for further consideration.	Proposed for up to 40 pitches. Due to size, scale and type of development the proposal will have a significant impact on the safety and capacity of the immediate local network in particular Route R133 St Brides Road and its junction with the B4045. On-site improvements are likely over the site's heritage with St Brides Rd. Existing access is not suitable, new access is achievable directly off St Brides Rd but will result in considerable loss of the existing boundary hedge. Will be located and accessible site. Public transport within 400m. TA would be required.	Designated locality: Magor and Undy. Near route MCC-S17C	No former use shown on historic maps but construction of the adjacent M4 could have affected this land. The site should be investigated, and if necessary remediated prior to introducing a receptor. Air quality and noise assessments are required due to proximity to the M4.	No real flood risk. S4B approval.	Site is relatively flat. Small fields bounded by hedges, trees (TPOs) and wooded areas to the north. Site not highly visible due to topography and vegetation. Sufficient space for tree planting to limit impact, incorporate SUDs and biodiversity net gain. Suitable for proposed development subject to an appropriate scheme.	The site comprises low-lying grassed fields surrounded by trees which may include veteran and over mature trees. The site is less than 200m from Grange Road SINC and less than 10m from Gwent Levels SSSI. The adjacent site was identified as priority grassland during the Monmouthshire LDP assessment (2010); surveys would be required to establish if the site meets priority grassland criteria. The woodland along the M4 corridor is likely to support dormouse, other species that may be present include bats (including roosts in trees), reptiles and nesting birds.	3a/3b	



Site Name and Address	Description on Asset Register	Area	Larger than 500sqm?	Inside Flood Zone (NRW Development Advice Maps)	Within or adjoining a Settlement boundary (as defined in adopted LDP)	Greenfield brownfield (as defined by Planning Policy Wales)	Surrounded by built development / privacy or amenity issues	Within BBNP or AONB	Within Green Wedge (as identified in adopted LDP) or within potential Green Belt	Within Phosphates Catchment Area	DES2 Allocation (as designated in adopted LDP)	DES2 in Review Recommendation	Within/adjacent to Conservation Area or Historic Park & Garden	Within Area of Archaeological Sensitivity	Heritage designations (LB, Con Area, Historic Park & Garden and SAMs) (state if within and adjacent)	Ecology Local Designations (SINC, Local Nature Reserves, TPO)	Ecology National Designations (state if within SSSI or SAC or RAMSAR or National Nature Reserve)	Landscape sensitivity (state classification on Landscape Sensitivity Study)	Mineral safeguarding (state if within current safeguarding area identified in Adopted LDP)	Proximity to 'bad neighbours' (distance from dual carriageway road, trunk road, motorway)	Contamination (viability of remediation) (state from MonMaps)	School proximity (state distance to catchment primary and secondary schools)	Medical facility proximity (state distance to nearest GP surgery)	Proximity to other amenities (e.g. shops) (state distance to nearest Main Town, Severnside)	Public transport proximity and frequency (SSA) - Medium frequency -	Constrained by topography	Vehicular Access (site specific checks later)	Ability to provide utility infrastructure (complete later)	Permanency (21 years+) (later)	Scope for future expansion if needed (later)	Considerations following site visit - should site progress for further consideration?	Highways Comments	Active Travel Comments	EHF/Public Protection Comments	Floods/SUDS Comments	GI Comments	Ecology Comments	Agricultural Land Classification	Generic Feedback from Gypsy and Traveller community	Travelling Ahead comments	Officer recommendation
Garth Close Open Space, Mitchell Troy, NP25 4JN	Public Open Space	1.56 acres	6318 sqm	No	Not adjoining settlement as defined in adopted LDP	Greenfield	Residential to north, east and south. Fields to west.	Within Wye Valley AONB	No	Upper River Wye Catchment	No	Not reviewed / no change likely	No	No	Listed building within 500m	SINCs within 200m	No	Adjacent to LCA MTD1 which is identified as high/medium sensitivity	No	Edge of cluster of homes forming Michel Troy Common	None	Kymin Primary 5.1 miles; secondary Monmouth - 3.4 miles	3.4 miles	Approx. 2.8 miles to Monmouth Town Centre	Daily frequency bus service available.	Site slopes from north to south	Existing field access of unadopted lane.		Yes - MCC owned	Some scope for future expansion depending on number of pitches initially provided and consideration of maximum desirable size limit.	Site should progress to the next stage of the process for further consideration.	Proposed site for up to 12 pitches. Accessed via private drive and abuts Route C47.3 Garrow Road near Route C47.1 Common Road 520 metres from Route R48, Mitchell Troy Road to the North and 1.45 km from the B4293 Monmouth Road to the South. Due to the size, scale, and type of development the traffic impact of the development is considered negligible but off-site improvements may be needed. The existing access routes are	Outside of locality. Nearest route MCC-M26B	No former development on the land. No objection based on information available.	No real flood risk to the site. Would require SAB if infiltration does not work the site has no identified surface water outfall easily achievable - watercourse to south-west would require access across existing hedge, would need to be removed. Based on the proposed	Site is an open square shaped area with existing hedges within the countryside, bounded by tree and hedge on all four sides. Several trees within the site. Site slopes from south to north. The area has a mix of architectural form, of single and two storey development and a mix of existing hedges. To create suitable access it appears a section of existing hedge would need to be removed. Based on the proposed	The site is bounded by native species hedge. Concern that part of the hedgerow will need to be removed to permit access. The quality of the habitats is unknown without surveys but it is likely that the hedgerow will meet priority criteria and there is potential for a mix of habitats near to the site. There are no statutory designated sites within 1km. Hedgerow access would make this site	2/3b	Generic feedback about rural sites. Travelling Ahead spoke to five households. Of these families, three commented on rural sites. Rural sites are considered to be easier to get planning permission due to fewer neighbours and less hostility. Putting sites near to settled community doesn't work. Feeling mutual of not wanting to live near each other (ie Travellers and the settled population).	Positive that it's not close to many existing homes and there is scope to develop the north/western side of the site and create a good margin. This site shouldn't go forward together with the Rocklea site. Site more preferable than Rocklea site. Being a sizeable site creates flexibility	Garrow Road is accessed via a steep, single track lane off a private lane with limited opportunities for improvement. The site is considered to be poorly located, the immediate area is not a sustainable location in terms of attractors and amenities and is considered to be too far outside of Monmouth to encourage walking and cycling. It is recommended that the site is not progressed further.
Manson Heights Amenity Land, Monmouth, NP25 5QX	Public Open Space	0.19 acres	775 sqm	No	Not adjoining settlement as defined in adopted LDP	Greenfield	Row of residential properties to south, fields/countryside to all other boundaries.	No	No	Upper River Wye Catchment	No	Not reviewed / no change likely	No	No	Listed buildings within 300m.	Cross Wood SINC within 350m.	No	LLCA M05 - High/medium sensitivity to residential development	No	Outside Monmouth development boundary; 250m to A466	Contaminated land point in northern part of site.	Obiston Primary 1.3 miles; Secondary Monmouth - 1.7 miles	1.5 miles	Approx. 1.8 miles to Monmouth Town Centre	Low frequency bus service available	Flat site	Access is via a single track from the A466.		Yes - MCC owned	No scope for future expansion	Access arrangement raise concerns. Site should progress to the next stage for further consideration.	Proposed for 1 pitch. Due to the size, scale and type of development the traffic impact would be negligible. Route C518.7 and C518.6 Manson Lane although narrow single lane rural lanes are considered capable of accommodating the insignificant increase in vehicle movements associated with the proposed development. No objection on safety and capacity of the adjacent highway network, however, the location is	Outside of locality with no routes nearby.	No former development on the parcel of land however former isolation (Infectious Disease) Hospital 30 metres south 1905-1964. No objection based on information available.	No real flood risk to require SAB. If infiltration does not work site has no identified surface water outfall easily achievable - water course to south west would require access across multiple third party land holdings.	Relatively well screened by native species hedge with trees and hedges. The general character of development within Manson and setting is rural with gardens, driveways, hedging and low walls to curtilage frontages and boundaries. Based on the proposed scale of development the site is potentially suitable, subject to an appropriate breeding birds and potentially reptiles and dormice. Layout would require appropriate	2	Generic feedback about rural sites. Travelling Ahead spoke to five households. Of these families, three commented on rural sites. Rural sites are considered to be easier to get planning permission due to fewer neighbours and less hostility. Putting sites near to settled community doesn't work. Feeling mutual of not wanting to live near each other (ie Travellers and the settled population).	Not suitable as too close to existing homes. Existing screening on two elevations is good. The provision of just one pitch isn't considered to be poor located, the immediate area is not considered the most sustainable location in terms of attractors and amenities and is considered to be too far outside of Monmouth to encourage walking and cycling. The site is accessed via two narrow single track lanes, the second of which has no	Having considered comments received from internal consultees, in particular the Highway Authority, officers consider the site to be poorly located, the immediate area is not considered the most sustainable location in terms of attractors and amenities and is considered to be too far outside of Monmouth to encourage walking and cycling. The site is accessed via two narrow single track lanes, the second of which has no	
Rocklea Open Space, Mitchell Troy, NP25 4JE	Public Open Space	0.74 acres	3035 sqm	No	Not adjoining settlement as defined in adopted LDP	Greenfield	Residential to south	Within Wye Valley AONB	No	Upper River Wye Catchment	No	Not reviewed / no change likely	No	No	None	SINCs within 500m	No	Partially within MTO3 LLCA - High/medium sensitivity	No	Edge of cluster of homes forming Michel Troy Common	None	Overmonnow Primary - 3 miles; secondary Monmouth - 3.5 miles	3.3 miles	Approx 3 miles to Monmouth Town Centre	Daily frequency bus service available.	Flat site but elevated above road	No existing vehicular access but potential for new access off Common Road. NB levels difference between road and site.		Yes - MCC owned	Some scope for future expansion depending on number of pitches initially provided and consideration of maximum desirable size limit.	No vehicular access identified but potential for new access off Common Road should be explored. Site should progress to next stage. For further consideration.	Proposed for 5 pitches. Directly abuts Route C47.1 Common Road, 720 metres from Route R48, Mitchell Troy Road a classified un-numbered road to the North and 1.25 km from the B4293 Monmouth Road to the South. Due to the size, scale, and type of development the traffic impact would be negligible. Site does not appear to benefit from an independent means of access. Access is potentially achievable directly off	Outside of locality. Nearest route MCC-M26B	No former development on the land. An operational sawmill 100m northwest has potential to impact on residents of site. May be necessary to request a noise impact assessment.	No real flood risk to the site. Likely to require SAB approval. If infiltration does not work site has no identified surface water outfall easily achievable. Watercourse to south west would require access across multiple third party land holdings.	Site is slightly elevated. The rural landscape rises to the west of the site and to the east is field and woodland associated with Garth Close. The area has a mix of architectural form, of single and two storey development and a mix of boundary treatments. To create a suitable visibility splay a significant section of existing hedge, trees and ground would need to be removed. This would not be acceptable from a	The site is bounded by native species hedge, part of the hedgerow will need to be removed to permit access. The quality of the habitats is unknown without surveys but it is likely that the hedgerow will meet priority criteria and there is potential for a mix of habitats near to the site. There are no statutory designated sites within 1km. It is recommended that the hedgerow loss would make this site unsuitable for proposed	2/3b	Generic feedback about rural sites. Travelling Ahead spoke to five households. Of these families, three commented on rural sites. Rural sites are considered to be easier to get planning permission due to fewer neighbours and less hostility. Putting sites near to settled community doesn't work. Feeling mutual of not wanting to live near each other (ie Travellers and the settled population).	Very close to existing homes. Although there is scope to develop the northern part of the site to create a margin, that impacts on the capacity and economical viability of the site. Current screening is generally good. Shouldn't be developed if the Garth Close site proceeds. The Gati Close site is considered more suitable than this site.	The site does not have an existing means of access. An access that accords with current design standard could be achieved directly off Route C47.1 Common Road but the lane is at a lower level and a new opening would result in considerable loss of the existing hedgerow to accommodate the means of access and visibility splays etc. and would also reduce the capacity of the site. The site is not



Land west of Grange Road, Dancing Hill (amended to include northern section of land - 3.87 acres), Dancing Hill, Magor with Undy, CALDICOT, NP26 3BY	Agricultural, Bare Land	3.14 acres	12,738 sqm	No	Adjoining	Greenfield	Residential to south and east (on opposite side of road), M4 to north.	No	No	No	No	Roughly 50% DES2 Amenity Land	Likely to delete DES2 designation as not publicly accessible	No	No	None	Group TPO along centre of site, adjacent to SINC (H4 neutral grassland)	No	Within MA05 LLCA - medium sensitivity to residential development	Mineral Safeguarding Area	Whole site within 150m of M4, closest part of site within 40m of M4	EA Historic Landfill Contaminated Landfill	Magor CW Primary School - 0.6 miles; Undy Primary School - 0.8 miles; secondary Caldicot - 4.3 miles	0.6 miles	Approx 0.4 miles to Magor Village Centre	Low frequency and daily frequency bus services available. Train station with frequent services at Caldicot and Severn Tunnel Junction.	Relatively flat site	New access off Grange Road	Yes - MCC owned	Some scope for future expansion depending on number of pitches initially provided and consideration of maximum desirable size limit.	Site should progress to next stage of assessment process.	Proposal for 14 pitches. Abuts Route C279.5 Grange Road. Works to provide footway on western side, road narrowing and priority give ways ongoing to accommodate a LDP housing development. Existing field access. Grange Road can accommodate the traffic flows arising from the size and scale of the proposal but the field access location conflicts with the road narrowing works and as such the development would.	Designated locally: Magor and Undy. Near route MCC-S13A	Former landfill site (1940-1960). Landfill gas monitoring undertaken in 1991 and 1992 250m away - did not find any landfill gas. Classified as high risk for human health in our contamination of land prioritisation list. Development of this land could not be undertaken without further planning conditions requiring contaminated land site investigation and remediation. TAN11 noise assessment required due to proximity to M4.	No real flood risk. Likely to require SAB approval. Nearby historic surface water flooding issues should be considered at design stage.	Northern edge of Undy. Relatively flat fields bounded by hedge to three sides and residential to south. Partly DES2 but currently grazed. Buffer to M4. Small group of TPO trees. Bounds the Grange Road SINC to the west. Part of the site is indicated as being an historic landfill site. Would need to ensure the DES2 area is still a publicly accessible area as part of the design. Space for tree planting.	Site comprises horse-grazed grassland with a central hedge with one veteran tree and borders the M4 wooded corridor to the north. The site is adjacent to Grange Road SINC noted for neutral grassland, and it is less than 1km from Gwent Levels SSSI. The woodland along the M4 corridor is likely to support dormouse, other species that may be present include bats (including roosts in trees).	3b	Generic feedback about semi-rural/edge of urban sites: Travelling Ahead spoke to five households. Of these families, three commented on semi-rural or urban sites. Semi-rural sites are considered to benefit from good transport links (needed for work purposes), supermarket deliveries and taxis. Being near shops is helpful but not so near that kids can walk off into town on their own and get into trouble. Urban sites are	Not considered suitable as too close to existing properties and close to M4 in terms of noise and pollution, although if any development this should be pushed to an acceptable margin from existing homes.	The site is suitable for residential development subject to a noise assessment due to proximity to the M4, subject to contamination remediation, and subject to an acceptable new access being provided on the bend of Grange Road. Better options are available.
Land at rear of Langley Close, Magor with Undy	Agricultural, Grazing	5.79 acres	23,431 sqm	No	Adjoining	Greenfield	Residential to south and east (on opposite side of road), M4 to north.	No	No	No	0.1ha of site DES2 on eastern boundary.	Likely to delete DES2 designation as not publicly accessible	No	No	Listed building within 200m of western end of site - site could be reduced in size to avoid impact	Within 200m of SINC (H4 neutral grassland). 2x TPO trees on eastern southern boundary	No	Within MA05 LLCA - medium sensitivity to residential development	Mineral Safeguarding Area	Whole site within 150m of M4, closest part of site within 40m of M4	No	Magor CW Primary - 1.3 miles; secondary Caldicot - 5 miles	0.4 miles	Approx 1.2 miles to Magor Village Centre	Low frequency and daily frequency bus services available. Train station with frequent services at Caldicot and Severn Tunnel Junction.	Flat site	Access off St Bride's Road	Yes - MCC owned	Site is much larger than needed. Scope to expand in the future if needed and still leave a buffer to the listed Building, but subject to consideration of maximum desirable size limit.	Site should progress to the next stage of the process for further consideration.	Proposal for up to 46 pitches. Due to size, scale and type of the proposal will have a significant impact on the safety and capacity of the immediate local network in particular Route R133 St Brides Road and its junction with the B4245. Off-site improvements are likely over the site's frontage with St Brides Rd. Existing access is not suitable, new access is achievable directly off St Brides Rd but will result in considerable loss of the	Designated locally: Magor with Undy. Near route MCC-S17C.	No former use shown on historic maps but construction of the adjacent M4 could have affected this land. The site should be investigated, and if necessary remediated prior to introducing a receptor. Air quality and noise assessments are required due to proximity to the M4.	No real flood risk. Likely to require SAB approval.	Site is relatively flat. 3 small fields bounded by hedge, trees and wooded buffer to the north with two storey residential to south. Partly DES2. Buffer to M4. Site not highly visible due to topography and vegetation. Sufficient space for tree planting to limit impact, incorporate SUDs and biodiversity net gain. Suitable for proposed development subject to an appropriate scheme.	The site comprises horse-grazed grassland surrounded by hedge, trees and wooded area which may include veteran and over mature trees. The site is less than 250m from Grange Road SINC and less than 1km from Gwent Levels SSSI. The adjacent area is identified as priority grassland during the Monmouthshire LDP assessment (2010); surveys would be required to establish if the site meets priority grassland criteria. The woodland	3a/3b	Generic feedback about semi-rural sites: Travelling Ahead spoke to five households. Of these families, three commented on semi-rural or urban sites. Semi-rural sites are considered to benefit from good transport links (needed for work purposes), supermarket deliveries and taxis. Being near shops is helpful but not so near that kids can walk off into town on their own and get into trouble. Urban sites are	Although close to existing homes, considered a possible option due to the ability to create a sizeable site to benefit from good transport links (needed for work purposes), supermarket deliveries and taxis. Being near shops is helpful but not so near that kids can walk off into town on their own and get into trouble. Urban sites are	The site is suitable for residential development subject to a noise assessment due to proximity to the M4. Contamination assessments could be undertaken as a precaution. The site is large enough to site 5-6 pitches well away from the Listed Building.	
CS00071 Slough Farm	Agricultural Land - RLDP Candidate Site	18.5 acres	7500 sqm	Small area of flooding Zone 2 total can be avoided	Adjoining	Greenfield	Residential to west, agricultural land to east and south and brownfield land to north on opposite side of A48 (MOD site)	No	No	No	No	Not reviewed / no change likely	No 160m to the west	No	Within 200m of SAM MM151 Crick Round Barrow	No	Within 200m of SSSI to the south of the site	High/Medium Sensitivity	No	Edge of Caerwent, working farmyard to western boundary	No	Catchment Primary Rogiet 3.3 miles Secondary Caldicot 2.6 miles	2.3 miles	Caldicot 2.4 miles	Daily frequency bus service available.	Flat site	Access directly off A48	Yes - MCC owned	Large site capable of expansion	The A48 is a strategic route and is considered more than capable of accommodating the additional traffic movements associated with a development of the size and scale proposed. However, creating a safe access off the dual carriageway will require a significantly re-engineered junction even though the proposal is for only 5-6 pitches.	The following comments were provided in relation to the RLDP candidate site: The site sits within a designated locality and within the Active Travel strategic focus distance of 3 miles to key destinations (education, health, employment and shopping). Good walking links are made out of the site and off-road provision is given to walkers and wheelers.	None.	The following comments were provided in relation to the RLDP candidate site: Not in flood zone. Need to consider water drainage as part of scheme	The following comments were provided in relation to the RLDP candidate site: It is considered from a Landscape and GI perspective that development of the proposed scale will have an adverse visual impact on Monmouthshire's wider landscape however the retention of existing boundaries with a well designed visual connection between existing settlement edge and	2/3a	Further consultation with Highways colleagues clarified that a significant re-engineered junction would be required on the A48. These works would be disproportionate in scale and it is recommended that the site is not progressed further.					

CS00067 Land East & West of Church Road	Agricultural Land - RLDLP Candidate Site	6.1 acres	24800 sqm	No	Adjoining	Greenfield	Residential to south, M48 to north, woodland areas east and west	No	No	No	Yes - land west of Church Road is DES2	Not known	No	Yes - land east of Church Road	No	No	Eastern site within 50m of SSSI	High/Medium Sensitivity	Mineral Safeguarding Area	Whole site within 150m of M48, closest part of site within 40m of M48	No	Catchment Primary Castle Park 0.7 miles, secondary Caldicot 1.1 miles	1.3 miles	0.75 miles to Caldicot Town Centre	Daily frequency bus service available.	Flat sites	Access off Church Road to eastern site. Access to western site problematic.	Yes - MCC owned	Large site capable of expansion	The following comments were provided in relation to the RLDLP candidate site: The highway authority considers that the site can be developed for the intended purpose, any mitigation and improvements will be subject to further review and analysis submitted in support of any future submission (Transport Assessment etc)	The following comments were provided in relation to the RLDLP candidate site: The highway authority considers that the site can be developed for the intended purpose, any mitigation and improvements will be subject to further review and analysis submitted in support of any future submission (Transport Assessment etc)	The following comments were provided in relation to the RLDLP candidate site: The highway authority considers that the site can be developed for the intended purpose, any mitigation and improvements will be subject to further review and analysis submitted in support of any future submission (Transport Assessment etc)	The following comments were provided in relation to the RLDLP candidate site: The highway authority considers that the site can be developed for the intended purpose, any mitigation and improvements will be subject to further review and analysis submitted in support of any future submission (Transport Assessment etc)	The following comments were provided in relation to the RLDLP candidate site: The highway authority considers that the site can be developed for the intended purpose, any mitigation and improvements will be subject to further review and analysis submitted in support of any future submission (Transport Assessment etc)	The following comments were provided in relation to the RLDLP candidate site: The highway authority considers that the site can be developed for the intended purpose, any mitigation and improvements will be subject to further review and analysis submitted in support of any future submission (Transport Assessment etc)	The following comments were provided in relation to the RLDLP candidate site: The highway authority considers that the site can be developed for the intended purpose, any mitigation and improvements will be subject to further review and analysis submitted in support of any future submission (Transport Assessment etc)	No - ALC for candidate site confirms no BMV	The site to the west of Church Road cannot provide an adequate vehicular access. The site to the east of Church Road offers little scope to provide a buffer between existing homes and the pitches on one side, and the M48 and pitches on the other side. Better options are available.
CS00221 Land at Penarth Farm, Llanishen	Agricultural Land - RLDLP Candidate Site	0.25 acres	1000 sqm	No	Adjoining	Greenfield	Agricultural fields to northwest, residential properties to other sides	Within AONB	No	Upper River Wye Catchment	No	Not reviewed / no change likely	No	No	No	No	No	High/Medium Sensitivity	No	Within village boundary of Llanishen, working farmyard to eastern boundary	No	Catchment Primary Trelech 2.3 miles, secondary Monmouth 8.5 miles	8.8 miles	Raglan 4.2 miles	Daily frequency bus service available.	Relatively flat site	Highways raised concerns	Yes - MCC owned	Limited size of site two pitches	The following comments were provided in relation to the RLDLP candidate site: The highway authority think that the size and scale of the development will have an impact on the immediate local highway network and the required level of mitigation and improvements is not achievable to support the proposed development although any future submission will be subject to detailed analysis and review undertaken	The following comments were provided in relation to the RLDLP candidate site: The highway authority think that the size and scale of the development will have an impact on the immediate local highway network and the required level of mitigation and improvements is not achievable to support the proposed development although any future submission will be subject to detailed analysis and review undertaken	None.	The following comments were provided in relation to the RLDLP candidate site: Not in flood zone need to consider from a surface water drainage as part of scheme	The following comments were provided in relation to the RLDLP candidate site: Not in flood zone need to consider from a surface water drainage as part of scheme	No comments	2	An acceptable access cannot be provided. It is recommended that the site is not progressed further.	
CS00211 Rockfield Farm Undy	Agricultural Land - RLDLP Candidate Site	6.7 acres	27000 sqm	No	Adjoining	Greenfield	Residential to south, M4 to north, agricultural fields east, housing development site to west	No	No - Green Wedge to East	No	No	Not reviewed / no change likely	No	No	Within 300m of SAM	No	No	High/Medium Sensitivity	Mineral Safeguarding Area	Whole site within 150m of M4 and M48 sliproad, closest part of site within 40m of M4 and M48 sliproad	No	Catchment Primary Undy Primary 1 mile Secondary Caldicot 3.0 miles	1.5 miles	Magor 1.4 miles away	Daily frequency bus service available.	Sloping site	Access directly off The Elms	Yes - MCC owned	Large site capable of expansion	The following comments were provided in relation to the RLDLP candidate site: The highway authority considers that the site can be developed for the intended purpose, any mitigation and improvements will be subject to further review and analysis submitted in support of any future submission (Transport Assessment etc)	The following comments were provided in relation to the RLDLP candidate site: The highway authority considers that the site can be developed for the intended purpose, any mitigation and improvements will be subject to further review and analysis submitted in support of any future submission (Transport Assessment etc)	The following comments were provided in relation to the RLDLP candidate site: The highway authority considers that the site can be developed for the intended purpose, any mitigation and improvements will be subject to further review and analysis submitted in support of any future submission (Transport Assessment etc)	The following comments were provided in relation to the RLDLP candidate site: The highway authority considers that the site can be developed for the intended purpose, any mitigation and improvements will be subject to further review and analysis submitted in support of any future submission (Transport Assessment etc)	The following comments were provided in relation to the RLDLP candidate site: The highway authority considers that the site can be developed for the intended purpose, any mitigation and improvements will be subject to further review and analysis submitted in support of any future submission (Transport Assessment etc)	The following comments were provided in relation to the RLDLP candidate site: The highway authority considers that the site can be developed for the intended purpose, any mitigation and improvements will be subject to further review and analysis submitted in support of any future submission (Transport Assessment etc)	27% Grade	The site is suitable for residential development subject to a noise assessment due to proximity to the M4. Contamination assessments could be undertaken as a precaution. The site is large enough to site 5-6 pitches well away from the Listed Building.	

Oakgrove Farm to the east of Bradbury Farm	Agricultural land	1.97 acres (total Candidate site)	2567 sqm (proposed Gypsy & Traveller site)	No	Not adjoining settlement as defined in adopted LDP	Greenfield	Agricultural land not currently surrounded by development however candidate site to form Caldicot East in RLDP. Scattered residential properties adjacent to parts of the wider candidate site.	No	No	No	No	No	No	No	No	No	High/Medium Sensitivity	Mineral Safeguarding Area	Open countryside.	No	Catchment Primary Archbishop Rowan Williams VA School in Portskewett which is located within 1.2 miles secondary Caldicot 1.2 miles	1.7 miles	1.5 miles to Caldicot centre	Daily frequency bus service available.	Relatively flat	Access directly off B4245	Yes - MCC owned	Large site capable of expansion	The following comments were provided in relation to the adjacent RLDP candidate site: The highway authority considers that the site can be developed for the intended purpose, any mitigation and improvements will be subject to further detailed review and analysis submitted in support of any future submission (Transport Assessment etc)	The following comments were provided in relation to the adjacent RLDP candidate site: From an environmental perspective the site is suitable to be developed for its intended purpose as submitted, or with appropriate mitigation and further dialogue with the LPA	The following comments were provided in relation to the adjacent RLDP candidate site: Not in flood zone need to consider surface water drainage as part of scheme	The following comments were provided in relation to the adjacent RLDP candidate site: It is considered from a landscape and GI perspective that a development of the proposed scale will have a significant adverse visual impact on monmouthshire valued landscape. The proposed site is detached from existing settlement and would appear to coalesce with Caldicot and Crick. The	The following comments were provided in relation to the adjacent RLDP candidate site: Site close / adjacent to a SAC/SPA/Ramsar/SSSI/LWS/SINCA SNW. Part of the site includes habitats that meet LWS / SINC threshold. Presence of Priority Habitat (Section 7) within the candidate site (except hedgerow). The Veteran / over mature tree(s) present. Site of existing value for connecting semi-natural habitats in the	Grade 2		The site is suitable for residential development. Its size means two sites of 5-6 pitches each could be provided.	
CS0251 Bradbury Farm	Agricultural Land - RLDP Candidate Site	4.38 acres (total Candidate site)	2500 sqm (proposed Gypsy & Traveller site)	No	Not adjoining settlement as defined in adopted LDP	Greenfield	Agricultural land not currently surrounded by development however candidate site to form Caldicot East in RLDP. Scattered residential properties adjacent to parts of the wider candidate site.	No	No	No	No	No	No	Within 55m of Mount Ballan House a Grade II Listed Building & 250m of SAM The Bernies Mound & Bailey Castle	Within 225m of SINC to the west	No	High/Medium Sensitivity	Mineral Safeguarding Area	Open countryside, north-west boundary is adjacent to the IM48 but development in this area can be avoided	No	Catchment Primary Archbishop Rowan Williams VA School in Portskewett which is located within 1.2 miles secondary Caldicot 1.2 miles	1.5 miles	0.75 miles to Caldicot Town Centre	Daily frequency bus service available.	Sloping site in parts, relatively flat in others.	Access directly off Crick Road or B4245	Yes - MCC owned	Large site capable of expansion	The following comments were provided in relation to the RLDP candidate site: The highway authority considers that the site can be developed for the intended purpose, any mitigation and improvements will be subject to further detailed review and analysis submitted in support of any future submission (Transport Assessment etc)	The following comments were provided in relation to the RLDP candidate site: The site sits within a designated locality and within the Active Travel strategic focus intended distance of 3 miles to key destinations (education, health, employment and shopping). Good walking links are made out of the site and off-road provision is given to walkers and wheelers.	The following comments were provided in relation to the RLDP candidate site: From an environmental perspective the site is suitable to be developed for its intended purpose as submitted, or with appropriate mitigation and further dialogue with the LPA	The following comments were provided in relation to the RLDP candidate site: Not in flood zone need to consider surface water drainage as part of scheme	The following comments were provided in relation to the RLDP candidate site: It is considered from a landscape and GI perspective that a development of the proposed scale will have a significant adverse visual impact on monmouthshire valued landscape. The proposed site is detached from existing settlement and would appear to coalesce with Caldicot and Crick. The	The following comments were provided in relation to the RLDP candidate site: Site close / adjacent to a SAC/SPA/Ramsar/SSSI/LWS/SINCA SNW. Part of the site includes habitats that meet LWS / SINC threshold. Presence of Priority Habitat (Section 7) within the candidate site (except hedgerow). The Veteran / over mature tree(s) present. Site of existing value for connecting semi-natural habitats in the	96.4% Grade 2 (34.7ha)		The site is suitable for residential development. Its size means two sites of 5-6 pitches each could be provided.
CS0222 Land at Penarth Farm Llanishen (Solar)	Agricultural Land - RLDP Candidate Site	21.25 acres	86005 sqm	No	Not adjoining settlement as defined in adopted LDP	Greenfield		Within AONB	No	Upper River Wye Catchment	No	No	No	No	Yes - TPOS onsite	No	High/Medium Sensitivity	No	Open countryside	No	Catchment Primary Trelech 2.3 miles Secondary Monmouth 8.5 miles	8.8 miles	Raglan 4.2 miles	Daily frequency bus service available.	Sloping site	Concerns over access to fields	Yes - MCC owned	Large site capable of expansion							60% Grade 2 16.4% Grade 3a 23.5% Grade 3b		Isolated site in open countryside - Not a sustainable site for residential use. It is recommended that the site is not progressed further.
CS0259 Bridge Farm Portskewett	Agricultural Land - RLDP Candidate Site	39.5 acres	84750 sqm	No	Not adjoining settlement as defined in adopted LDP	Greenfield	Agricultural land not surrounded by development however candidate site to form Caldicot East	No	No	No	No	No	Yes	Within 150m of Listed Building to west and 34m of Registered Garden St Pierre Park	No	Within 500m of SSSI	High/Medium Sensitivity	Partially Mineral Safeguarding Area	Open countryside	No	1.8 miles to ABW, 3.2 miles to Caldicot School	1.8 miles	1.8 miles to store in Portskewett, 4.0 miles to Caldicot	Daily frequency bus service available.	Flat site	Access off highway network	Yes - MCC owned							2		Isolated site in open countryside - Not a sustainable site for residential use. It is recommended that the site is not progressed further.	
CS0066 Bridge View Farm adj Nantgavenny Business Park	Agricultural Land - RLDP Candidate Site	1.5 acres	8125 sqm	No	Adjoining	Greenfield	Business units to north, residential development to east, care home to south, woodland to east	No	No	Upper River Usk Catchment	No	No	No	No	Adjacent to ancient woodland	Adjacent to SINC		No	Business units to north	No	King Henry VIII 3-19 school 1.1 miles	1.8 miles	1.4 miles to Abergavenny town centre	Medium frequency bus service on Hereford Road, Abergavenny train station	Relatively flat site	Site accessed via business / light industrial park. Not suitable for residential development	Yes - MCC owned	Some scope for future expansion depending on number of pitches initially provided and consideration of maximum desirable size limit.									Site would be accessed via business / light industrial park. Not suitable for residential development. It is recommended that the site is not progressed further.

CS0069 Raglan Enterprise Park, Raglan	Agricultural Land - RLDP Candidate Site	31.6 acres	128000 sqm	No	Not adjoining settlement as defined in adopted LDP	Greenfield	Employment units to east, residential to north	No	No	Upper River Usk Catchment	No	Not reviewed / no change likely	No	No	340m to Listed Building to North of site	No	No	High/Medium Sensitivity	No	Sewage works	Yes small area contaminat ed due to sewerage works	360m to Raglan Church in Wales Primary , Secondary School Monmouth 7.5 miles	0.2 miles	450m to Raglan	Daily frequency bus service available.	Sloping site	Access directly to Chespstow road		Yes - MCC owned	Large site capable of expansion								98% Grade 3a			Reputed site in open countryside - Not a sustainable site for residential use. It is recommend ed that the site is not progressed further.
---	--	------------	------------	----	---	------------	---	----	----	---------------------------------	----	---------------------------------------	----	----	---	----	----	----------------------------	----	-----------------	---	--	-----------	-------------------	---	--------------	--	--	--------------------	---------------------------------------	--	--	--	--	--	--	--	-----------------	--	--	--

## Appendix 4

### Minutes of Cabinet 4<sup>th</sup> October 2024

That Cabinet accept the recommendations as set out below:

Ratification of the proposal to remove the following sites from the site identification process as per the statement made to Cabinet on the 26th of July 2023 by the then Cabinet Member for Inclusive Communities:

- Manson Heights, Monmouth
- Garrow Road, Mitchel Troy
- Rocklea, Mitchel Troy.

Following further consideration of feedback from the Place Scrutiny Committee on the 19th of July 2023 and the wider Magor and Undy community, ratification of the proposal to remove Dancing Hill West, Magor from the list of potential sites, as per the reasons stated in paragraph 3.9.

Following a review of Council owned 'Candidate sites', to put forward two sites of up to 6 pitches each at the Caldicot East strategic site identified within the Replacement Local Development Plan Preferred Strategy.

The commencement of a public consultation exercise on the following Council owned sites (site summary profiles provided in Appendix 1), for the potential provision of up to six Gypsy, Roma and Traveller pitches each:

- Bradbury Farm, Crick, Caldicot
- Oak Grove Farm, Crick, Caldicot
- Langley Close, Magor.

Inclusion in the public consultation, any suitable sites brought forward through the public call for sites, that the owner is willing to sell or lease long term to the Council.

Further exploration of the 19th July Place Scrutiny Committee's request to support households wishing to self-serve on existing sites which, subject to the necessary permissions, would reduce the number of new pitches needed.

To approve the attached FAQs (Appendix 2), an iterative document which will be displayed and regularly updated on the Council's website.

This page is intentionally left blank



## Gypsy and Traveller

Consultation report

## Monmouthshire

Monmouthshire County Council

# Contents

---

1. Executive Summary .....	3
2. Introduction .....	4
Overview .....	4
Overview of consultation process .....	4
3. Background .....	5
Process of allocating Gypsy and Traveller sites .....	5
Council's Gypsy and Traveller Accommodation Assessment .....	5
Identifying sites .....	5
4. Consultation tools .....	9
Webpage .....	9
Feedback form .....	9
Media release .....	9
Poster .....	10
Social media toolkit .....	10
Drop in events .....	11
5. Feedback summary .....	14
6. Feedback from drop in events .....	16
7. Feedback from key stakeholders .....	20
8. Feedback from the Gypsy & Traveller community .....	54
9. Feedback from survey responses .....	55
Langley Close .....	60
Bradbury Farm and Oak Grove Farm .....	64
10. Summary and conclusion .....	68
Statement from the Council .....	69
11. Appendices .....	70
Appendix 1 Consultation programme .....	70
Appendix 2 Feedback form (paper) .....	71
Appendix 3 Consultation launch media release .....	79
Appendix 4 Drop in events poster advert .....	80
Appendix 5 Social media toolkit .....	81
Appendix 6 Exhibition boards .....	84
Appendix 7 Photos to support the consultation .....	93



# 1. Executive Summary

---

- 1.1 This consultation report details the findings for Monmouthshire County Council's Gypsy and Traveller consultation and the key issues raised by residents and stakeholders during the consultation.
- 1.2 The consultation delivered was in accordance with the consultation plan which can be found in **Appendix 1**.
- 1.3 The key headlines include:
- 410 people provided feedback to this consultation, via completing a paper or online feedback form, email, or telephone.
  - The consultation was reached by more than 30,000 social media users and there were almost 1,500 total views to the webpage.
  - Feedback on sites range from concerns about noise and pollution to road safety and impact of neighbourhoods.

## 2. Introduction

---

### Overview

2.1 Monmouthshire County Council (MCC) has a legal and moral duty to ensure everyone has access to good quality homes. The Council recognises that safe, culturally appropriate accommodation is necessary for individuals to flourish in other parts of their lives.

2.2 The Council's Gypsy and Traveller Accommodation Assessment (GTAA) has identified a need for an additional 13 pitches for the Gypsy and Traveller families already living in Monmouthshire.

2.3 Three Council-owned sites in Monmouthshire have been identified as potentially suitable to meet the current needs for the Gypsy and Traveller community:

- Oak Grove Farm, Crick
- Bradbury Farm in Crick
- Langley Close in Magor.

### Overview of consultation process

2.4 A six-week consultation was launched on 9th November 2023 seeking feedback from the community about the proposals. This is being run by Grasshopper Communications on MCC's behalf. The closing date for feedback was 22nd December 2023.

2.5 This consultation report and accompanying appendices provides an overview of the consultation undertaken and a summary of the feedback received and responses.

## 3. Background

---

### Process of allocating Gypsy and Traveller sites

3.1 The process of allocating Gypsy and Traveller sites is a lengthy process and can take several years before sites can be developed. The following steps are currently being implemented and at each stage there will be public engagement:



### Council's Gypsy and Traveller Accommodation Assessment

3.2 The Council is required to undertake a Gypsy and Traveller Accommodation Assessment (GTAA) every five years. This is a legal obligation under the Housing (Wales) Act 2014. The [Council's 2021 GTAA](#) identified the need for 13 pitches for families already living in Monmouthshire. Where a pitch need is identified, the Council is also required under the Housing (Wales) Act 2014 to meet that need.

3.3 The Council is required to allocate land to meet its housing needs, including the identified need for the Gypsy and Traveller sites in its Replacement Local Development Plan (LDP). The current LDP was adopted in 2014 and is now being reviewed. The preparation of the Replacement LDP 2018-2033 is now underway and will identify the proposed sites for Gypsy and Traveller communities.

### Identifying sites

3.4 Work commenced on considering the Council's broad approach to identifying land for Gypsy & Traveller pitch provision in 2018. But the more concentrated activity has taken place since the completion of the Gypsy and Traveller Assessment 2021.

- 3.5 The aim of the process has been to identify and shortlist parcels of land that are potentially suitable for providing Gypsy, Roma and Traveller pitches that will meet the Council's need, which the Council can then consult upon. Following consultation, a decision will be made on the most suitable sites, these sites will then be included in the Replacement Local Development Plan.
- 3.6 To help develop the Council's site identification process and to explain the Council's legal responsibilities, a schedule of both informal and formal meetings has taken place to capture the knowledge and views of local elected Council Members and to help inform the site identification process.
- 3.7 The Council's site identification process has reviewed and evaluated all of the Council's 1500 Council assets. The core of the site identification process was a broad five staged exercise to sift out/remove unsuitable land using site evaluation criteria, the aim being to identify a short-list of land with potential suitability for development as Gypsy, Roma and Traveller pitch provision, which would then be consulted upon.
- 3.8 This staged exercise to sift out unsuitable assets has been recorded and evidenced in a document, referred to as the [RAG document](#) (a spreadsheet that utilises a traffic-light system of red, amber and green to colour code evaluation findings and provide a more visual indication/overview). This staged process and the RAG document informed the original proposal on the Cabinet agenda on [26th July 2023](#).
- 3.9 Throughout this process, Council Officers have regularly consulted with Scrutiny Members on progress. Full details of these meetings can be found here:
- [Report to Joint Select Committee to scrutinise Gypsy and Traveller Assessment, 10/12/2020 10:00 \(monmouthshire.gov.uk\)](#)
  - [Report to Adults Select Committee to scrutinise site identification, 21/09/2021 10:00 \(monmouthshire.gov.uk\)](#)
  - [Report to Adult Select Committee to include process in forward work programme, participate in workshops, scrutinise methodology for evaluation, invite support from Travelling Ahead, 20/07/2022 10:00 \(monmouthshire.gov.uk\)](#)
  - [Report to Cabinet to approve and adopt Gypsy and Traveller Assessment, 06/01/2021 14:00 \(monmouthshire.gov.uk\)](#)
- 3.10 At the People Scrutiny Committee held on the 19th of July, the Committee was asked to consider the following recommendations from the [Report to People Scrutiny Committee 19th July 2023](#) to scrutinise proposal to consult on four sites and undertake investigative work on a fifth site.

The Scrutiny Committee made a recommendation to reject the four recommendations presented and to recommend that the Members put out a

public call to landowners to come forward with parcels of land, which is in line with recommendation 2.3 of the Cabinet report and that the selection process begin again.

3.11 The report put to [Cabinet 26th July 2023](#) recommended "the commencement of a consultation exercise to look at the following Council owned sites for the potential development of Gypsy and Traveller pitch provision namely:

- Manson Heights, Monmouth
- Rocklea, Mitchel Troy
- Garthi Close, Mitchel Troy
- Langley Close, Magor

Agree that further evaluation is undertaken on an additional piece of Council owned land, to further inform possible suitability and if applicable, (subject to findings) future consultation.

- Dancing Hill, Undy (west of Dancing Hill)

Agree to a 'call' for landowners who may wish to suggest parcels of land to come forward for consideration and further consultation."

The decision taken by Cabinet on 26th July 2023 was to "*Defer consideration of the report to allow officers to undertake further work.*" The then Cabinet Member also advised that three sites be removed from the site identification process due to unsuitability namely Manson Heights, Monmouth; Rocklea, Mitchel Troy Common and Garthi Close, Mitchel Troy Common.

In addition, officers were tasked with the following:

- Review site evaluation work and the RAG document;
- Incorporate and review Council owned candidate sites put forward for potential allocation in the RLDP for development [nine areas of land]. These were previously sifted out on the basis of the potential future development considerations;
- Invite the public to put potential land forward for consideration; and,
- Continue to seek to address need wherever possible on existing private Gypsy, Roma and Traveller sites subject to the necessary permissions.

3.12 Further to the Cabinet meeting of the 26th July 2023, the following work has taken place and conclusions drawn:

- a. The site identification RAG document has been reviewed by officers to ensure comments and RAG ratings are robust and consistent. The most recent version of the RAG document can be viewed [here](#). Given a combination of the known historic land contamination, possible noise

issues, access issues and location immediately adjacent to a Site of Importance for Nature Conservation (SINC), officers recommend that Dancing Hill West is removed from the process as alternatives are available.

- b. Officers have further reviewed Council owned 'Candidate sites' put forward for potential inclusion in the RLDP. These nine sites are now included in the most recent version of the RAG document.
- c. Following the 'Candidate' site review, two sites at the RLDP strategic Caldicot East site have been identified for up to 6 pitches each; one at Bradbury Farm and one at Oak Grove Farm.
- d. The 'public call' for sites was a positive exercise which resulted in 17 pieces of land being suggested for use. 14 of the sites put forward were discounted following the same approach as the sifting of MCC land or due to inadequate information to identify the location. Three suitable pieces of land have been assessed using the RAG. The Council has written to the owners of the three suitable sites to determine if there is any interest in selling or leasing this land to the Council.
- e. Discussions are ongoing with existing Monmouthshire households wishing to self-serve on existing sites, in respect of meeting their own need subject to the necessary permissions.

3.13 The outcome of this work and conclusions were reported to Cabinet on [4th October 2023](#) and informed a revised proposal to consult on three sites. It was agreed to start the public consultation exercise on three sites as well as including any suitable sites brought forward through the public call for sites, that the owner is willing to sell or lease long term to the Council.

3.14 The Cabinet decision was subject to a Call-in request which was considered by Place Scrutiny on 23rd October and referred to County Council on 26th October. County Council agreed to proceed with the consultation on the three identified sites.

## 4. Consultation tools

---

- 4.1 The consultation on the emerging proposals took place between 9th November and 22nd December 2023.
- 4.2 A variety of consultation tools were used to encourage participation in the consultation from stakeholders and the local community which are set out below. This level of participation is consistent with the need for pitches identified by the Gypsy and Traveller Accommodation Assessment.

### Webpage

- 4.3 A webpage was set up to provide information about the consultation and included further information on the process of allocating Gypsy and Traveller sites, the Council's Gypsy and Traveller Accommodation Assessment, the proposed Gypsy and Traveller sites, consultation events, feedback mechanisms and contact details so local communities and stakeholders can find out more and comment on the emerging proposals:  
<https://www.monmouthshire.gov.uk/gypsy-roma-traveller-sites-consultation/>.
- 4.4 976 unique visitors accessed the website during this consultation process: 969 to the English version and 7 to the Welsh version. Overall, there were 1,557 total visits to the English page and 31 to the Welsh page (combined total of 1,589).

### Feedback form

- 4.5 An online feedback form was produced to gather feedback during the consultation. This was made available on project website at the start of the consultation at <https://www.monmouthshire.gov.uk/gypsy-roma-traveller-sites-consultation/>.
- 4.6 Hard copies were available at the face-to-face events and returned to the Caldicot Hub (located in Caldicot Library, Woodstock Way, Caldicot, NP 26 5DB); or posted to Housing & Communities, Monmouthshire County Council, County Hall, The Rhadyr, Usk, NP15 1GA. A copy of the feedback form is attached at **Appendix 2**.

### Media release

- 4.7 A media release was sent to local media to introduce the project and publicise the consultation on 8 November. It was released two days earlier than the consultation launch to coincide with the South Wales Argus's weekly printing date (see **Appendix 3**).
- 4.8 Press coverage during the consultation included:

Date	Paper	Headline and link
7/11/23	Monmouthshire Council	<a href="#">Gypsy and Traveller pitches in Monmouthshire</a>
9/11/23	News, Wales	<a href="#">Drop-in sessions organised by Monmouthshire County Council to discuss Gypsy Traveller site plans</a>
9/11/23	Monmouthshire Beacon	<a href="#">Proposed Monmouthshire gypsy pitches up for consultation</a>
9/11/23	Herald Wales	<a href="#">MONMOUTHSHIRE: Gypsy consultation events</a>
12/12/23	South Wales Argus	<a href="#">Monmouthshire Gypsy Traveller sites consultation deadline</a>
12/12/23	Nation Cymru	<a href="#">Gypsy traveller site consultation deadline looms</a>
12/12/23	News.Wales	<a href="#">Residents urged to have their say on potential gypsy traveller sites in Monmouthshire</a>
14/12/23	The Forest of Dean and Wye Valley Review	<a href="#">Drop-in day deadline for Monmouthshire gypsy site consultation</a>

## Poster

4.9 An A4 poster was displayed locally, to advertise the events (see **Appendix 4**).

## Social media toolkit

4.10 A social media toolkit was prepared (refer to **Appendix 5**) to help raise awareness of the project and publicise the consultation events and how to give feedback. It was issued to Monmouthshire County Council to use on its Facebook and Twitter/X pages channels.



4.11 Combined, in total, these posts reached 33,683 users and were engaged with 90 times (29 reactions, 2 comments and 59 shares).

## Travelling Ahead

4.12 The consultation was promoted by Travelling Ahead in a number of ways. This included promoting it through Travelling Ahead's Facebook and Twitter social media accounts. Travelling Ahead also made contact directly with members of their network including members of the Gypsy & Traveller community and specific agencies. Travelling Ahead's engagement with the Gypsy & Traveller Community involved taking consultation documents to people's homes.

## Other

4.13 Outside of the Council's mechanisms it is also known that the consultation was informally promoted by some of the Council's elected members through their own networks, detailing how residents can get involved and reminders of deadlines and meeting dates.

## Drop in events

4.14 The purpose of the drop in events was to give the local community an opportunity to discuss the project with the project team and raise any concerns they may have.

4.15 The following drop in events took place:

Date	Time	Venue	Number of attendees
<b>Wednesday 22nd November 2023</b>	4pm to 7pm	Portskewett Church Hall, Portskewett, NP26 5UL	117
<b>Thursday 23rd November 2023</b>	4pm to 7pm	Magor and Undy Hub, Main Road, Caldicot, NP26 3GD	88

4.16 Portskewett Church Hall and Magor and Undy Hub were chosen because they were geographically very close to the proposed sites. The halls were large which enabled everyone who attended to view the exhibition materials with ease. They also had good disabled access, adequate public transport links, and free parking onsite or on road.

4.17 There were nine English and nine Welsh exhibition boards with the following information:

- **Welcome** – Introducing attendees to the drop-in event and contact information is provided.
- **Process** – Explaining the GTAA and proposed next steps after this consultation period.
- **Site map** – Pinpointing the location of the three proposed sites in one map. It also clearly indicates the location of the proposed land submitted for RLDP Caldicot East.
- **Feedback** – Showing ways of providing feedback during this consultation process.
- **Profile: Langley Close** – Describing the Langley Close site, including site size and pitch capacity.
- **Profile: Oak Grove Farm** – Describing the Oak Grove Farm site, including site size and pitch capacity.
- **Profile: Bradbury Farm** – Describing the Bradbury Farm site, including site size and pitch capacity.
- **Vision** – Highlighting the Council's moral and legal duty to meet the pitch needs for Gypsy and Traveller communities in Monmouthshire.
- **Key documents for download** – Showing QR codes of RAG, the Gypsy and Traveller Assessment, Welsh Government guidance and planning, frequently asked questions, and the consultation website.

4.18 The boards were produced and displayed in English and Welsh at each of the venues and were available to download as a PDF from the project website from the day of the first drop-in event. The exhibition boards are attached as **Appendix 6**.

## Targeted Gypsy and Traveller drop-in event

4.19 A further drop-in event targeting the Gypsy and Traveller community was held to provide a safe space to support their engagement in the process and ask questions specific to their needs.

Date	Time	Venue	Attendees
------	------	-------	-----------

<b>Tuesday 5th December 2023*</b>	4pm to 7pm	Monmouthshire County Council, County Hall, Rhadyr, Usk, NP15 1GA	3
-----------------------------------	------------	--	---

4.20 Three individuals attended the event at County Hall, of which one was a known member of the local Gypsy and Traveller community who represented a number of households. Travelling Ahead also directly engaged with the Gypsy and Traveller community about the consultation and encouraged participation.

4.21 It is recognised that engagement with the Gypsy & Traveller community can be difficult because members of the community may not feel confident nor comfortable participating, possibly in part due to a lack of trust. It is equally recognised that building trust and relationships necessary for effective engagement can take time. In addition, the fact that the known Gypsy & Traveller community in Monmouthshire is very small will also be of relevance. The Council is keen to continue engaging and developing relationships with the Gypsy & Traveller community.

4.22 It is Travelling Ahead's view that the low participation is absolutely no reflection of the lack of need for land to be identified for meeting future pitch need.

## 5. Feedback summary

---

### Drop in events

5.1 A total of 206 residents and stakeholders attended the three drop in events:

Date	Venue	Attendees
<b>Wednesday 22nd November 2023</b>	Portskewett Church Hall	117
<b>Thursday 23rd November 2023</b>	Magor and Undy Hub	88
<b>Tuesday 5th December 2023</b>	County Hall, Usk	3
<b>Total</b>		<b>208</b>

5.2 The summary of the feedback received at these events is provided in section 6 of this report.

### Emails / telephone enquiries

5.3 A total of **17 emails** were received during the non-statutory consultation with:

- 12 of these were emails from local residents, to which their feedback is embedded into the survey responses in section 9 of this report.
- Five of these were received from elected representatives, feedback is summarised in section 7.
- A number of photographs and one video were submitted by email to illustrate certain comments made.

5.4 **Two telephone** enquiries were received.

### Feedback forms

5.5 During the consultation, **389 feedback forms** were completed online or returned using the freepost address, two of which were in the Welsh language. Forms that were sent originally by email were later submitted online and form part of the 389 figure. Of these:

- 338 provided feedback on Langley Close.
- 243 provided feedback on Bradbury Farm.

- 232 provided feedback on Oak Grove Farm.
- 223 provided additional comments regarding all three sites.
- 282 provided feedback on Monmouthshire County Council's vision.
- 220 provided additional comments about the consultation.

5.6 A total of 374 of the 389 people responded to the question “How useful was the information received during this consultation?”. Of those that responded, 27% found the information ‘very useful’ or ‘useful’ while 37% either found it ‘not very useful’ or ‘not useful at all’:

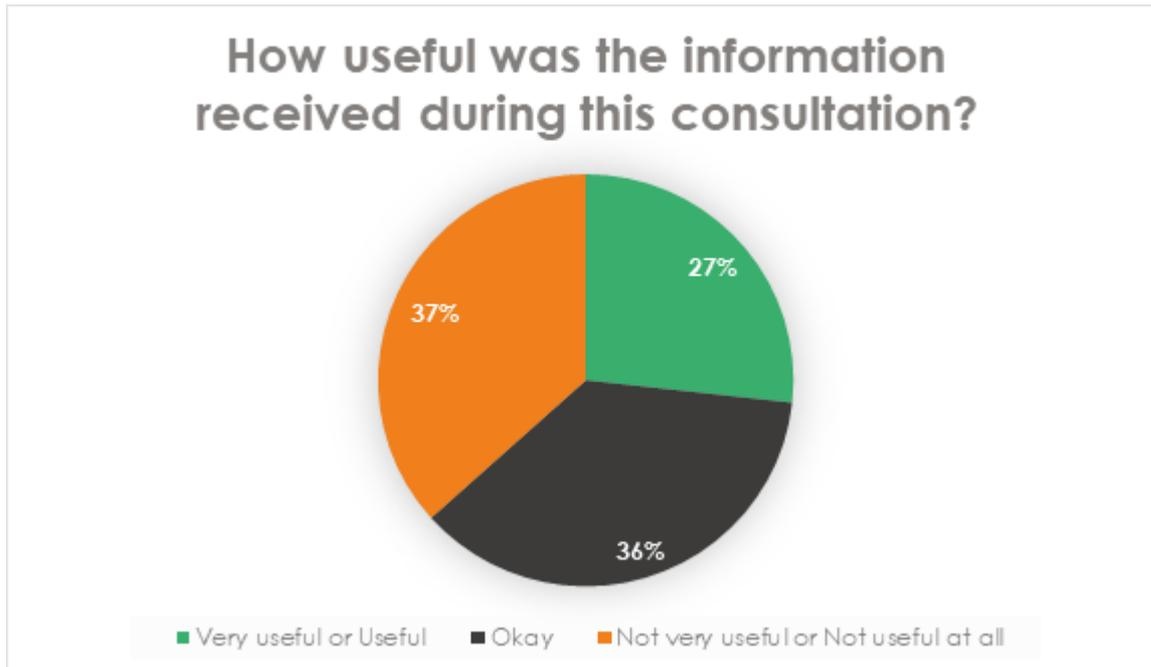

## E-Petitions

5.7 Three e-petitions were submitted by members of the general public, one was prior to the consultation period while the other two were submitted during the consultation period. One of the e-petitions was rejected because it contained intemperate, inflammatory, abusive, or provocative language so has not been included in this report.

5.8 **Petition 1 (before consultation): Save our Green Open Areas** ‘We the undersigned petition the Monmouthshire County Council to acknowledge the result of the scrutiny committee and to withdraw the proposals to develop both the Langley Close and Dancing Hill sites due to their unsuitability and the further loss of the limited remaining ecologically rich green areas within our village and community.’ **1,256 people signed this petition.**

5.9 **Petition 2: Protecting Open Space** ‘We the undersigned believe the two sites proposed are unsuitable for development of any kind, including as sites for the gypsy traveller community and we call on the County Council to withdraw them.’ **678 people signed this e-petition.**

# 6. Feedback from drop in events

---

6.1 The key issues raised during the drop in events were:

## Event one: Portskewett Church Hall

- Location of Oak Grove** – Attendees raised various issues in relation to the proposed Oak Grove Gypsy and Traveller site including:
  - Traffic speed is too fast and accidents or near misses are considered common.
  - The site is too windy for caravans.
  - Concerns that the reflected heat from the solar panels will be intolerable.
  - Poor accessibility relating to lack of pavements and street-lighting.
- Location of Bradbury Farm** – People raised various issues in relation to the proposed Bradbury Farm Gypsy and Traveller site including:
  - The site is located on an S bend making access potentially dangerous.
- Road safety** – Some attendees highlighted that Oakgrove and Bradbury Farms are located on roads with the national speed limit (60mph), making it potentially unsafe for those living there. Some stated that the amount of traffic on the roads is likely to increase with new developments e.g. MOD and Treetops.
- Overdevelopment** – Some attendees stated that there are a couple of significant housing developments in the Crick/Portskewett area; one that is near completion while the other is yet to be submitted for planning permission. They raised concerns about too much development in southern part of Monmouthshire and the potential impact of these developments on local infrastructure and community services (roads, public transport, schools, dentists, doctors etc).
- Providing homes for all** – Queries were raised about why provision is being made for the Gypsy and Traveller community, when there is a housing crisis for all with many young people not being able to access housing in the area. They felt more should be done to shorten the current waiting list for social housing and there should be greater provision for homeless people in Monmouthshire.
- Views about Gypsy and Traveller communities** – In those few cases where the views expressed were discriminatory in nature, they have been discounted.
- Consistency of planning decisions** – The proposal for the Gypsy and Traveller sites is inconsistent with previous planning decisions for housing development which had been refused. There was a query as to why these sites would be considered suitable for this type of accommodation.

8. **Site names** – Bradbury Farm, according to some of the residents, is named inaccurately as it is further down that road which is causing some confusion.
9. **Management of sites** - Some views and comments were received about a risk of possible site management implications, for example, unauthorised use. Queries were also received about whether rent would be charged to utilise the site. In those few cases where the views expressed were discriminatory in nature, they have been discounted.
10. **Property values** – Some residents were concerned about the impact on their property values if a Gypsy and Traveller site was located in the area. One attendee had been advised by an estate agent that their property value has been affected and people are declining to view because of the possibility and uncertainty regarding a potential Gypsy and Traveller site.
11. **Cost of sites** – There were queries around who would be paying for the development of the sites.
12. **Other local Gypsy and Traveller sites** – Some attendees made comments about a privately owned site in the County, speculating that appropriate planning approvals were not in place. They felt Monmouthshire County Council is not dealing with it effectively.
13. **Loss of agricultural land** – Concerns were raised about loss of agricultural land and the impact on the local food supply.
14. **Consultation feedback** – Attendees raised that the link to the on-line feedback form wasn't working.
15. **Cost of consultation** – Queries were raised about the cost of the consultation.
16. **Other issues** – Some who attended used the event raised other issues not related to the Gypsy and Traveller consultation including complaints about the Welsh Government policy to introduce a 20mph speed limits in residential areas.

## Event two: Magor and Undy Hub

1. **Location of Langley Close** – People raised various issues in relation to the proposed Gypsy and Traveller site behind Langley Close including:
  - Noise levels (being in close proximity to the M4). They raised the fact that properties near the M4 have received compensation and have had triple glazing is an indication that Langley Close is an inappropriate location for mobile homes.

- Light pollution and privacy issues impacting on properties.
  - Too close to residents (some identified that they thought it was a requirement/preference that Gypsy and Traveller communities for sites should not be close to other residential properties).
  - Poor accessibility stating that part of the road is very narrow and there is no footpath. St Brides Road is a blind bend and is a narrow road through a residential area which would be inappropriate for regular large vehicles, Lorries already get stuck there. See **Appendix 7** for photos.
  - Attendees felt that the site is not urban.
  - Issue of highway flooding – see **Appendix 7** for photos.
2. **Traffic impacts** – Attendees raised that the increase in traffic is a concern which is further compounded by the current development of the Andrews logistics depot, Magor.
  3. **Overdevelopment** – Concerns were raised about too much development in this part of Monmouthshire and the potential impact of these developments on local infrastructure, community services (roads, public transport, schools, dentists, doctors etc). These close-knit communities fear their loss of community identity.
  4. **Lack of green space in Magor** - Attendees raised the lack of community sports facilities as well as lack of dog walking areas locally.
  5. **Property values** – Some residents were concerned about the impact on their property values if a Gypsy and Traveller site was located at Langley Close.
  6. **Council risk of litigation** – Some residents claimed if the site was developed, the Council would be at risk of litigation due to the issue of pollution.
  7. **Process** – There were perceptions that the proposed sites were a ‘done deal’ and a decision about allocating the sites had already been made. Some attendees felt that completing the feedback surveys alongside the consultation was too late to inform the consultation.
  8. **Consultation publicity** – People raised concerns that the consultation had not been promoted adequately. Some residents in and around Langley Close were not happy about the promotion of the consultation, some of whom were informed of this event a lot later than others. Many had not seen the press release and did not use social media. They had not seen posters or received any newsletter. Many had only heard of the consultation through word of mouth.
  9. **Views about Gypsy and Traveller communities** – There were a number of discriminatory views expressed through the events. These comments have not been included and have been discounted.



10. **Proposed timeline** – Some expressed surprise about how long it can take for the sites to be built, should they be approved.

### **Event three: Monmouthshire County Hall**

The household attending this drop-in was supported by Travelling Ahead. The household verbally advised that they welcomed that the Council was seeking to identify sites for Gypsy & Traveller households.

# 7. Feedback from key stakeholders

## Elected representative responses

7.1 Responses were provided by the following elected representatives:

Name	
Role	
Medium of response	Feedback received
<p><b>David TC Davies MP</b> MP for Monmouth</p> <p><b>Email</b></p>	<p>There is a great deal of local concern about the suitability of the three sites in question. Langley Close, which is next to the M4, has been questioned by both the public and councillors about the health impacts of potential air pollution. It is also very close to existing homes. Indeed, feedback from the gypsy traveller community was they did not wish to be sited in close proximity to built-up areas.</p> <p>Although the other two sites are identified as being in Crick, the proposed Bradbury Farm site will be located on the northern perimeter of the farm in the Portskewett ward – while the Oak Grove Farm site is situated on land alongside Severn Farm in Leechpool, Portskewett. The council has said the gypsy traveller sites need to accommodate a combined total of 13 pitches and that a pitch is around 320 square metres, so 13 pitches across the entire county requires just over an acre of land. The county has 200,000 acres, yet the only sites deemed “suitable” are all within the Severnside area.</p> <p>The council's own scrutiny committee recommended going back to the drawing board following a review of previously earmarked land, which saw sites dropped at Mitchel Troy Common and Manson Heights in Monmouth. But instead, two new sites have been identified in Portskewett. I am doubtful that any officers or cabinet members have visited either of the sites as the one referred to as Oakgrove</p>
	<p>Farm in Crick is 2.4 miles away from Oakgrove Farm in Caerwent. Incorrectly identifying Portskewett ward as Caldicot East is misleading. If the council cannot accurately pinpoint a site location,</p>

	<p>it raises questions as to whether a thorough assessment has been carried out.</p> <p>In the Severnside corner of Monmouthshire, there are already well-founded overdevelopment concerns. An area the local authority has dubbed Caldicot East, which also encompasses the adjoining village of Portskewett, could see up to 2,609 new homes built by 2033. The sites proposed at Bradbury Farm and Oak Grove Farm are inappropriate due to the volume of houses that have already been built and the 750 to 1,400 houses Portskewett could be allocated in the future, risking its identity as a village. It is all too much in an area that is becoming overdeveloped.</p> <p>Finally, I echo local road safety fears. The two locations in Portskewett are located on 50mph roads with blind bends. The B4245 is dangerous to pull out on, let alone walk along. I do not believe they are suitable for the gypsy traveller community or for development of any kind. There are no safe routes to access local amenities and children will not be able to safely walk to school.</p>
<p><b>Peter Fox</b> <b>MS</b></p> <p>MS for Monmouth</p> <p><b>Feedback form</b></p>	<p><b>On the vision:</b> As a recent, long-standing Leader of Monmouthshire County Council I understand well the need for the council to have a clear vision and aspirations for the Gypsy &amp; Traveller community. As in recent past, small sites would seem to be most suitable. Of course, as with any development they should be well designed, fit in with the landscape and surrounds, and be subject to the same planning and development conditions as required for any other development that would be applied for though the planning system. What is important is that proposed sites should be genuinely considered from the Gypsy &amp; Traveller perspective as well as from the settled community perspective. The convenience of the council, i.e. utilising their own land holdings should not be the driver for proposed site selection albeit I can see why the council may see that utilising their own land would be convenient and desirable.</p>
	<p><b>On Langley Close's advantages:</b> This site isn't in my constituency however as a past MCC councillor I know it relatively well. There are few, advantages of this site. I feel it has been put forward due to it being a spare piece of land that is conveniently located on the boundaries of the village of Magor and as such would have access to local facilities such as schools, village centre etc. This rationale may carry some merit however I would argue that should those factors be the driver over the wider needs of gypsy traveller families? The</p>

convenience of the location should be very much a secondary consideration and should not cloud the view of decision makers.

**On Langley Close's disadvantages:** This site isn't in my constituency, but I know it relatively well from my past councillor role. The site is located very close to several established residential houses. For sufficient space to ensure both the Gypsy and Traveller community and the local residents to have their respective privacy, it would seem that proposed area of the site would require the pitches to be located very near to the motorway, one would have to ask if this would be fair to the Gypsy / Traveller families? They would be located to such a potentially undesirable spot with additional noise and pollution and possible safety concerns. Would the planning system view a proposed, western position of the site, indeed any of the site, being in such close proximity to a motorway and subject to the concerns I raised? Would it be seen as suitable for permanent residential use? I feel the site would almost traps any new gypsy and traveller families between the motorway and settled homes, forcing the two communities together which I doubt would be desirable by either.

**On Bradbury Farm's advantages:** The site is located close to surrounding villages and Caldicot and it is accessible.

**On Bradbury Farm's disadvantages:** This site would be highly visible from Crick Road it is a relatively exposed site there would be no safe walking routes to the local amenities or schools. Crick Road is a busy road as it links the A48 to the B4245 and is used as heavily by traffic. Indeed, I would not walk myself along that stretch and certainly would not want children to try walk it. Safe walking routes should be a fundamental consideration for any new development and that should include for our Gypsy Traveller sites. Again, I feel the perceived convenience of this site by decision makers has allowed this site to come forward without deeper consideration. I was also surprised to see the council bring this site forward recognising an accepted position agreed by both the gypsy and traveller community and the planning authority where it is seen that gypsy and traveller sites should not be located closely to settled communities. I state this as the MCC proposed Local Development Plan has identified large areas of land, adjacent to this site for large scale new housing developments. Clearly if these proposals are seen as sound in a final LDP and are developed I would ask how would this proposed site be conducive with the wider residential aspirations of the council? There seems to have been little consideration of this conflict in policy. The location of a gypsy traveller site here could jeopardise future development and vice versa.

**On Oak Grove Farm's advantages:** Firstly, this proposed site is not part of Oak Grove farm, it is situated as part of what was Severn Farm and now farmed by the tenants of Parkwall Farm. I was the County Councillor covering this area for some 25 years and I can hand on heart say this site has absolutely no strengths or advantages. The only thing I can see that might have made it desirable was that it has an established gateway, again I sadly have to state that I feel that this site was put forward due to that simple fact which isn't a deep enough rationale for something so important.

**On Oak Grove Farm's disadvantages:** As previously stated I know this site exceptionally well as was the county councillor for the ward for 25 years, I was also on the community council for a similar time. I was amazed to see this proposed site coming forward and can only assume it was chosen as it has a convenient gateway that is set back from the B4245. If that gateway wasn't there this site would just be another field like the hundreds of others in the area that border roads such as the A48 or in this case the B4245 but haven't been considered. I strongly believe that there should be a far stronger rationale to bring a site forward other than in this case a convenient access. The reasons I believe this site is so wrong are firstly based on safety. I would argue that the B4245 is one of the busiest roads in Monmouthshire. As local housing developments have been delivered along Severnside we have seen a huge increase in traffic volume. The B4245 is used not only by cars but large volumes of heavy goods vehicles who use it to access local industry sites. Indeed, the traffic has got so bad it has become extremely dangerous for existing residents to access the road from their own residential drives. Over many years I have witnessed a vast number of accidents and near misses. The community council and I as a past local member have lobbied for reduced speed to prevent accidents, but to no avail, yet traffic now is increasing exponentially. To locate any further residence, either Gypsy Traveller, or regular residential, would be madness. To require gypsy traveller families to live there would be so unfair on them. The danger for them and especially their children would be significant. I genuinely believe that regular access from the proposed site onto the B4245 would result in the loss of life at some point and should be resisted at all cost. I say this as a local resident myself who knows well what conditions are like there and who has seen things get worse. There are also no safe walking routes along the B4245 to enable children and parents to access local schools and facilities. All new residential developments of any nature should have appropriate pedestrian access. Aside from my main concerns about the safety of the site, it would also be very exposed and would be highly visible from both, the A48 and the B4245. In planning terms, I believe this site would be totally

	<p>unacceptable on so many grounds that I'm surprised political leaders brought it forward.</p> <p><b>Further comments:</b> As a local Senedd Member and a past Council Leader and long-standing councillor. I have been disappointed to see how the county council's Cabinet has gone about conducting this process and choosing potential sites. Initially there was a lack of consultation albeit it these latter stages lessons seem to have been learnt and there has been engagement. I strongly believe that the needs and desires of the Gypsy and Traveller have not been thought out properly and that decision makers have been driven to bring forward their proposals due to other factors such as availability of their own land and superficial considerations such as convenient access opportunities. It seems little consideration, certainly on two of the sites, has been given to children safety, safe walking routes and future planning considerations. I would also point out that little consideration has been given to the already approved Gypsy Traveller sites, or those in long term use such as Usk or Llancayo. How should these be viewed in terms of the Gypsy and Traveller needs assessment? If they haven't been included in the overall Gypsy and Traveller considerations should they be?</p>
<p><b>Natasha Asghar MS</b></p> <p>Regional MS for South Wales East</p> <p><b>Email</b></p>	<p>Natasha believes that there does need to be housing somewhere and that everyone deserves a place to live.</p> <p>It is vital all residents are consulted and inform their local Councillors of their views. Ultimately Monmouthshire should be a safe and lovely place to live for everybody. Natasha is sure that with the opinions of residents heard, the Council will make the right decision.</p>
<p><b>Cllr Frances Taylor</b></p> <p>Councillor for Magor West</p> <p><b>Email</b></p>	<p><b>Introduction</b></p> <p>I would like to formally submit my consultation response in respect of the Gypsy Traveller Pitch Provision for both Langley Close and Dancing Hill. I am aware that Cabinet has currently ruled Dancing Hill out as per paragraph 3.9 of the cabinet report of 4<sup>th</sup> October 2023.</p> <p>3.9 Given a combination of the known historic land contamination, possible noise issues, access issues and location immediately adjacent to a Site of Importance for Nature Conservation (SINC), officers recommend that Dancing Hill West is removed from the process as alternatives are available.</p> <p><b>General comment on Magor with Undy</b></p>

Magor with Undy has just been designated a Town in the boundary changes. This is for no other reason than the disproportionate growth Magor with Undy has seen. In the 1980's /90's Magor with Undy was one of the fastest growing settlements in Europe. However, little or no regard was paid to creating sustainable, connected communities. There is no civic footprint in respect of libraries, leisure provision, tourist information, civic buildings etc.

There is a general feeling in the community that Monmouthshire Council and its predecessor councils has not sought protect and enhance its natural and historic assets such as outdoor amenity space, Wilcrick Hill Fort, Medieval Orchard, Mill Common's ancient woodland and the Gwent Levels and the SSSI's to name but a few important features.

### Process

I believe that both sites are unsuitable and would request that this is acknowledged. However, the fact that Cabinet further ruled out the Dancing Hill site, whilst the right decision provides further evidence that the process has been flawed from the outset. This is because all the facts that ruled 4 of the 5 sites out were known at the outset.

Therefore, how can one have confidence in a process which would serve up 5 sites and then rule 4 of them out without any further investigation?

For the record, I have repeatedly made representations concerning the process which Monmouthshire Council has followed. I continue to believe that process is flawed and not fit for purpose. In Pre-decision scrutiny, the People Scrutiny committee of 19<sup>th</sup> July, supported Option 3, not to recommend any of the sites to Cabinet to be formally consulted upon but instead to recommend that Cabinet returns to the drawing board. The Council proposed 5 pieces of land for consultation in July. Of the 5 pieces of land proposed all were rejected by scrutiny. Cllr Jackie Strong, Labour member and vice chair of the People select committee described the proposals as "a pig in a poke".

If the process was robust, accurate and objective – why have four of the five original sites been ruled out? I feel that this provides further evidence that the original process is irrevocably flawed.

However, the Cabinet's attachment to these sites and unwillingness to consider the evidence base has served to undermine confidence in the process and also in the wider RLDP.

There were and still appear to be inaccuracies, inconsistencies and erroneous information in the site assessment and RAG process.

### **Initial Inaccuracies and Inconsistencies**

The report advises that at stages 1, 2 and 3 land was removed where it was,

- Covered by a ground lease – Langley Close is currently leased/licensed.
- County Farm Holdings- both Langley Close and Dancing Hill are County Farm Holdings
- Woodland areas – Both Langley Close and Dancing hill are bounded by wooded areas and adjacent to what we understand to be ancient woodland
- Within and adjacent to conservation areas - Both Langley Close and Dancing hill are adjacent to Magor Conservation area.
- Enclosed/surrounded by built environment and amenity/placemaking – Both Langley Close and Dancing hill are enclosed and surrounded by the built environment and amenity space. It is axiomatic that matters of privacy and amenity would be significant factors for all parties. Magor Town Council along with the Council are embarking on placemaking plans which include considerations of amenity space and active travel corridors.
- National ecological designations/Landscape designation – Both Langley Close and Dancing hill are within 70 m of a SINIC and are within 500m of Landevenny and Redwick SSSI
- Listed Buildings – Langley close is bounded by Woodland House to the Western Boundary. Woodland House, the former Vicarage is a Grade 2 listed building designed by the same architect as Tyntesfield, the National Trust Property (John Norton). The building is habitat for known protected species and this was documented during the M4 public inquiry.
- Proximity to “bad neighbours” – The sites are in placed within 25 -50 Metres of the M4
- Access - Access, St. Brides Road is a national speed limit road which is single track and now much more heavily trafficked



due to the 20 MPH. It is also unsuitable for HGV's. The Highway assessment advises that the current access is unsuitable, and the size and scale of development will have a significant impact on the safety and capacity of the immediate local network and that the existing access is unsuitable. A new access would result in significant loss of the ancient boundary hedge.

- Mineral Safeguarding – Langley close is a Mineral Safeguarding area.
- Designated amenity space - Both Langley Close and Dancing hill contain designated amenity space, which is vital to the communities of Magor with Undy.
- Greenfield - Langley Close is considered a greenfield site in the officer assessment – it was only recently drawn to officer attention that this may require some investigation of the land due to proximity to the M4 and historic potential for tipping during its construction. Dancing hill is believed to formerly be a landfill site and will it seems require some potentially significant investigation.

In general site descriptions remain poor and inaccurate with arbitrary detail. Similar features are not described consistently. For example, Langley close only makes mention of properties on the Southern Boundaries but as above, it is bounded to the north west by Grade 2 listed Woodland House, to the south west by Langley Close and Newport Road and to the east by St. Brides Road and Langley Villa and to the North by an oversection of the M4 and slip roads for Junction 23.

During the scrutiny committee, officers did offer the view that there is an inherent level of subjectivity in the descriptions and argued that no site is perfect. However, I would suggest that there are many factors associated with these (and the other sites) which are not a matter of interpretation or subjectivity or indeed balance. For example, the site is either bounded by properties or it is not. There is either a listed building in close proximity or there is not. These are not a matter of subjective interpretation but a matter of fact.

- GI and Ecology. One small example is that other sites recognise clear GI features, e.g. bounded by native species hedgerow and that to create a suitable visibility splay would require removal of existing hedgerow and trees – in some sites this is RAG rated green and in others red.
- Despite recognising the potential for protected species, the proximity from the SINC and the SSSI and the adjacent site

DES 2 as recognised as priority grassland, the ecological features of the sites do not seem adequately described in the assessment.

The site descriptions seem to lack detailed local knowledge and the RAG Rating Framework seems subjective, arbitrary and has been inconsistently applied. Additionally, Gypsy and Traveller Family comments appear to suggest that none of the sites under consideration are helpful, in respect particularly of proximity to existing built environment.

In the report pack it is advised that the workshop on 4th July 2023 'considered 9 remaining sites and whether to leave in process and recommend consulting on possible development or remove from process.' No recommendation is in the agenda but somewhere, either in this meeting or afterwards, 4 have been removed and only 5 sites are being presented at the People's Scrutiny Committee. This member workshop appears to have been used to "filter out" sites, where members were asked for their views. Members will not necessarily have the local knowledge necessary to fully appraise sites and as above the information on each site seemed inconsistent and arbitrary.

Equally, member workshops are in my experience only ever used as a means of providing members with information, training and knowledge and sometimes seeking member feedback. They are not decision-making fora and this does not accord with my understanding of Monmouthshire Council's constitution. Just preceding the workshop on 4<sup>th</sup> July is the first-time members have received any documentation. Officers confirmed this at the scrutiny meeting.

### **Deficit in Outdoor Space**

Magor with Undy has a significant deficit in outdoor space. I raised particular concern about the Langley Close site. Over the past 7 years I have been at pains to get the council to firstly identify Council owned sites in Magor with Undy which could be considered in particular for outdoor formal sport provision. I have been working with officers and local sport groups to persuade the Council to allocate land for recreation and outdoor sport. In the end, there were only 3 flat, drained sizeable sites in the Council's ownership in Magor with Undy, which were thought to be possible for consideration. Langley close was one of the sites. I visited the site with the Council's Community Infrastructure Co-ordinator when we were considering options. At the time the land was not tenanted. I have been working with Magor Rugby club to make a change of use application on one of the other identified sites at Knollbury, the

Rose Cottage site. The Rose Cottage site was selected in preference because it is larger.

It is my firm belief that as there are no other identified drained land in council ownership which is large enough for outdoor recreation and formal sport provision, the Langley close site should not be lost to any other uses – whatever they might be.

I have also been approached by Undy AFC as they are saturated and cannot take other young players without further pitch allocation. Yet Undy AFC has growing demand in new player interest from our expanding local population. Undy is fortunate to have a well-engaged & enthusiastic volunteer capacity, and also a good governance structure. Undy AFC has achieved FAW's platinum accreditation for the club, which is the highest level possible for a grassroots club. The club has 350 junior players, male & female, making Undy one of the biggest clubs in the region. There are 7 senior teams, including 2 women's teams. The age range of players at the club is 2 to over 60, and the club would love to be able to do more but are now limited by pitch space. Undy is doing great things with the ongoing growth of female football, but still only have room for 4 girls' teams, when the mixed/boys teams are currently numbering 15 - they still have some way to go. Undy also other local community sporting groups, but again these are limited due to capacity.

<b>Typology</b>	<b>Current level of provision (hectares per 1000 people)</b>	<b>Current level of provision (hectares)</b>	<b>Standard per 1000 population (hectares)</b>	<b>Open space required to meet standard (hectares)</b>	<b>Surplus or deficiency (hectares)</b>
Public open space	0.37	2.25	0.4	2.44	0.19 (deficiency)
Outdoor sport	0.64	3.92	1.6	9.75	5.83 (deficiency)
Natural and semi-natural green space	2.72	16.58	2.0	12.18	4.40 (surplus)

Equipped play spaces	0.09	0.57	0.3	1.82	1.25 (deficiency)
Informal play spaces	0.37	2.25	0.5	3.05	0.80 (deficiency)
Allotments	0.07	0.40	0.25	1.52	1.12 (deficiency)

The Town Council MUGA (formerly tennis courts) is saturated, and council has considered (and applied for via the Council's Community Infrastructure co-ordinator) funding for further court provision to meet the needs and desires of the community.

The Ashley Godfrey open spaces report from 2008, prepared as a support document for the current LDP – and below is the surplus/deficiency table of provision. The slight inaccuracy of this relates to allotments - only the Greenmoor Lane and Sycamore Terrace allotments were included and there are allotments in Undy which will bring us closer to sufficiency in pure standard per 1000 population terms. However, at the time of writing, the Town Council has 50 people on a waiting list for an allotment.

There is a current deficiency of 5.83 hectares (14.41 acres) of Outdoor Sports provision when the standard of 1.6 hectares per 1000 population is applied.

Current provision amounts to 3.92 hectares compared to a requirement of 9.75 hectares.

The Rose Cottage site measures 4.52 hectares so, if and when this site is brought into use for outdoor sports provision, it will reduce the deficit to 1.31 hectares.

The Langley Close site measures 2.34 hectares and ought to be retained as farmland with the option to use in the future for open space use and in particular outdoor sport.

There have been several completions on Rockfield Farm and Vinegar Hill which were not reflected in the census date. There are many further completions due at Rockfield Farm and Vinegar Hill. There are also further residential candidate sites in the new Replacement LDP, and consideration must be given to population growth and the needs of future generations.

### **Further material planning considerations**

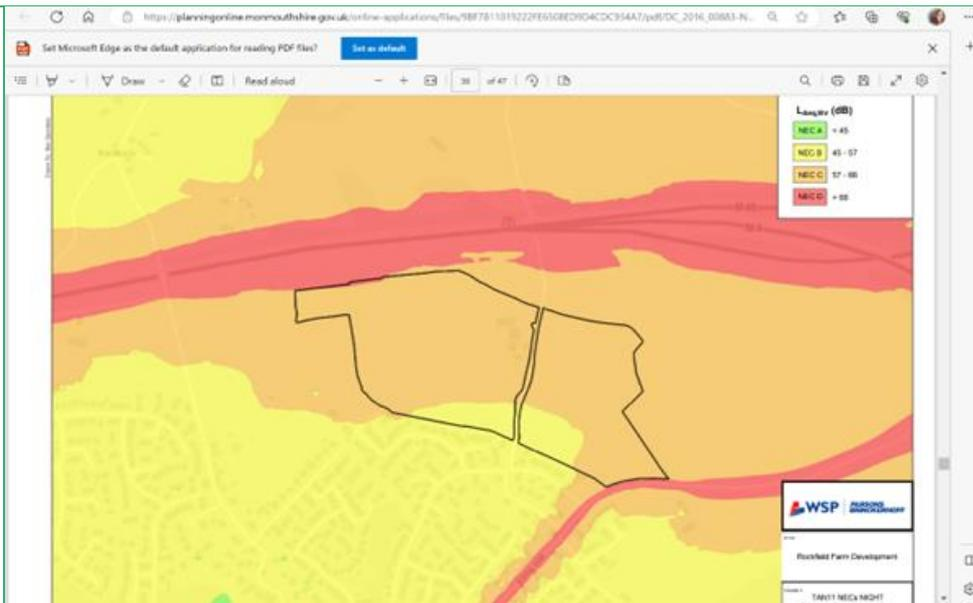

### Noise Pollution

Both sites are adjacent to the M4 motorway and raised slip road to Junction 23A. According to the Dept for Transport, traffic has increased by 21% since the tolls were abolished in 2018 (actual counts).

Noise pollution is a key concern and going back to the noise studies for Rockfield Farm for comparison, I anticipate they are similar if not worse. You will note that most of Rockfield Farm fall into NEC category C (TAN 11).

NEC C - Planning permission should not normally be granted. Where it is considered that permission should be granted, for example because there are no alternative quieter sites available, conditions should be imposed to ensure a commensurate level of protection against noise.

Below are night-time noise levels from a study conducted for the Rockfield Farm Masterplan in 2016.

As above, planning permission ought generally not be granted. Traffic levels have grown exponentially. and the matter worsened. One anticipates that this pattern is replicated at Dancing Hill. It is likely worse at Langley close where the M4 is raised and there are also the on and off slips for Junction 23.

- **Pollution and Contamination**

It is noted that the Dancing Hill site is a potential Landfill site. Additionally, it is true to say that many sites alongside the M4 are potentially contaminated with unregulated tipping carried out

during construction works during the 1960's. Both sites would need appropriate testing.

Air pollution levels are extremely high as shown by the National Atmospheric Emissions Inventory, below.

The current greenfield sites at Langley Close and Dancing Hill provides a buffer between the M4 and current residential areas. This attenuates some of the noxious air pollution. Equally, Welsh Government Document, 'Designing Gypsy and Traveller Sites May 2015', para 3.21 states: *'If a location is considered inappropriate for conventional housing use, on the grounds of health and safety, then it should also be considered inappropriate for a Gypsy and Traveller site. A Gypsy and Traveller site should not be located in areas which will have a detrimental effect on the general health and well-being of the residents.'*

#### AIR POLLUTANTS

DATA RETRIEVED FROM THE NATIONAL ATMOSPHERIC EMISSIONS INVENTORY (NAEI) WEB SITE. PART FUNDED BY THE WELSH GOVERNMENT.

THE NAEI COMPILES ESTIMATES OF EMISSIONS TO THE ATMOSPHERE FROM UK SOURCES SUCH AS CARS, TRUCKS, POWER STATIONS AND INDUSTRIAL PLANTS. THE FOLLOWING HAZARDOUS AIR POLLUTANTS ARE ALL IN THE RED CATEGORY IN THE AREA BETWEEN JUNCTION 23A AND LANGLEY CLOSE:

- ARSENIC
- CADMIUM
- CHROMIUM
- CO2 AS CARBON
- COPPER
- HYDROGEN CHLORIDE
- LEAD
- MERCURY
- NICKEL
- PARTICULATE MATTER 10 AND 2.5
- VANADIUM AND ZINC.

A NUMBER OF THESE AIR POLLUTANTS CAUSE RESPIRATORY DAMAGE, KIDNEY AND BONE DAMAGE WITH HIGH LEAD LEVELS KNOWN TO CAUSE LEARNING DIFFICULTIES.

NAEI, UK National Atmospheric Emissions Inventory  
<https://naei.beis.gov.uk>

#### ● Designated Amenity Space

Dancing Hill and part of Langley Close are both Designated Amenity Space (DES2). We have already lost sections of designated amenity space due to the Rockfield Farm development. As above Magor with Undy is underprovided with open space. Planning Policy mitigates against the loss of DES2 land. I note that the RAG Assessment proposes to remove DES2 Area of Amenity Importance status from the Langley Close and Dancing Hill sites. From the community's perspective it is not clear how or why the existing designated area of amenity importance can be considered to be less important than it was previously, to a degree which would remove these policy protections and actively promote development within the area. Indeed, the area of DES 2 has been curtailed to

allow for the M4 safeguarded route. Now this designation has been removed, the whole area should return to DES2 status.

- **Flood Risk**

The Langley close site as a green field provides a natural soakaway for surface water. The Mill Reen is a main river and St. Brides Road is subject to both surface water and run off from the Mill. Any development could reduce the natural soakaway resulting in more surface water run off onto St Brides Road.

- **Green Infrastructure and Ecology**

Very little has been made of the Green Infrastructure at Langley close and Dancing Hill, but it forms part of an important green corridor with mature native species. Removal of hedgerow to create a visibility splay would damage the landscape and character. Despite recognising (in the rag rating) the potential for protected species, the proximity from the SINIC, the SSSI and the adjacent site DES 2 as recognised as priority grassland, the ecological features of the sites do not seem adequately described in the assessment. There are active badger setts at Langley Close.

- **Highway Access**

Neither Langley close of Dancing Hill have suitable access or safe highway arrangements for active travel. St. Brides Road is a national speed limit road which is single track and now much more heavily trafficked due to the 20 MPH. It is also unsuitable for HGV's. St. Brides Road is less than 3.2 metres wide and has a series of blind bends.

The Highway assessment advises that the current access is unsuitable, and the size and scale of development will have a significant impact on the safety and capacity of the immediate local network and that the existing access is unsuitable. A new access would result in significant loss of the boundary hedge.

Visibility from any new site entrance / exit will be restricted and non-compliant with highway safety regulations.

Welsh Government Document, 'Designing Gypsy and Traveller Sites May 2015', para 3.24' states:

'Good quality roads which are capable of withstanding heavy vehicles should be constructed. Normally concrete or tar macadam on a suitable sub-base appropriate to soil conditions is preferable. Roads should be wide enough to allow mobile homes access on low loader vehicles and yet not encourage on road parking. Roads

	<p>should be a minimum of 5.5 metres wide and accommodate vehicles towing caravans up to 10 metres long.'</p> <p>One of the Dancing Hill sites has been filtered out due to access, yet the remaining site (which is opposite) has been assessed as having potential for a further improved access at the widest point of Grange Road, which is also a dangerous bend and would be in close proximity to the Vinegar Hill development access.</p> <p><b>Other factors</b></p> <p><b>Economic factors</b></p> <ul style="list-style-type: none"> <li>• It appears that some other sites have been ruled out on economic grounds. The Welsh Government capital grant would fund the capital cost of constructing a site. However, it will the feasibility studies such required ecology, contamination studies, noise studies, traffic assessments. It should be noted that the contamination study proposed are only desktop based and further work could be required.</li> </ul>
<p><b>Cllr John Crook</b></p> <p>Councillor for Magor East and Undy</p> <p><b>Email</b></p>	<p><b>It's the last day for the Consultation with regards to the Langley Close site in Magor.</b></p> <p>As you both are aware I have made several objections to this proposed site and have asked for it to be withdrawn from the process.</p> <p><b>However I am asking again for this site to be removed from the process in question, as it's a very poor third choice when you look at the other Two sites in the mix.</b></p> <ol style="list-style-type: none"> <li>1. As I understand the Gypsy Travellers do not want to occupy this site, if this is so maybe you can confirm that this is the case?</li> <li>2. If this is the case as per the above, then why are we pursuing the site (Langley Close) as an option!</li> <li>3. The Weaknesses outweigh the Strengths by far which sorely must be taken into consideration!</li> <li>4. Threats / Risks are a problem going forward!</li> <li>5. The Key Internal Feedback Comments – Highways are not good reading!</li> </ol>



	<p>Therefore, with all this in mind I am asking you to remove this proposed site from the mix as it really is a Very Poor Third option.</p>
<p>Magor with Undy Town Council</p> <p><b>Email</b></p>	<p>Magor with Undy Town Council Understands the Monmouthshire Council's duty to address the identified needs for Roma, Gypsy and Traveller Pitch Provision.</p> <p>The Town Council notes that Dancing Hill has been removed from the process by the Cabinet Member for Sustainable Economy and then formally at the Cabinet meeting of 4th October 2023. However, the Council has commented on the suitability of Dancing Hill as the reasons provided in the Cabinet report are almost identical to the issues at Langley Close and furthermore the report states one of the reasons for removal is that other sites are available. To this end, should any of the other sites be ruled out, the Town Council would not wish to see Dancing Hill ruled in. The Town Council believes that both sites are wholly unsuitable for Gypsy and Traveller accommodation. The Cabinet report of 4th October contains the following paragraph.</p> <p>3.9 Given a combination of the known historic land contamination, possible noise issues, access issues and location immediately adjacent to a Site of Importance for Nature Conservation (SINC), officers recommend that Dancing Hill West is removed from the process as alternatives are available.</p> <p>Furthermore, the Town Council wishes to draw attention to the process, which it has found wholly unsatisfactory. The identification process appears extremely subjective, and the level of inconsistency and error suggests that those involved were not familiar with either Langley Close or Dancing Hill during the selection process. The Town Council noted with interest that the cross-group Pre-decision scrutiny meeting concluded that all the sites were unsuitable for Gypsy and Traveller accommodation. The People Scrutiny committee of 19th July, chaired by Cllr Crook resolved to support Option 3, not to recommend any of the sites to Cabinet to be formally consulted upon but instead to recommend that Cabinet returns to the drawing board.</p> <p>The Town Council has sought to inform and engage residents in the land identification process. The Council has also engaged with Travelling Ahead.</p>

### **Submission to object to potential candidate allocation sites for Gypsy and Traveller pitches, at Langley Close, Magor**

1. Magor with Undy Town Council has approved this submission which seeks the removal of the following sites from consideration for allocation for development of gypsy and traveller pitches in the review of the Monmouthshire Replacement Local Development Plan (MRLDP). The sites in question are as follows:  
Land off Langley Close, Magor  
Land off Dancing Hill, Magor
2. In support of this submission, a number of separate points are made under headings in the sections which follow.

#### **Site identification and Assessment Process**

3. It is understood that no Candidate Sites for Gypsy and Traveller Accommodation were put forward in the Monmouthshire Council's initial or second call for sites exercise. In accordance with Welsh Government Guidance, the council is investigating the potential of providing the accommodation identified as required through the Gypsy and Traveller Accommodation Assessment, on land it owns.
4. An initial assessment of 1500 sites filtered out sites which could not meet a minimum area requirement of 500 square metres, were located in areas of flood risk and which were County Farm holdings, and other criteria. This led to the retention of 70 sites. A second assessment updated the consideration of flood risk in accordance with updated TAN15, with 50 sites remaining.
5. Throughout, sites with uncertain inputs were carried forward to the next stage. 17 sites were subject to a RAG assessment and five have been put forward to members of Monmouthshire County Council for consideration and a decision on whether to proceed to consultation on potential allocation for the development of Gypsy and Traveller accommodation.
6. Within Magor with Undy, two sites have been included in the final five. The first site is land off Dancing Hill and the second site is Land off Langley Close. On the traffic light (RAG)

assessment of 35 (assessed) criteria, more than one third are yellow or red for each site.

### **Consideration of farming activity and agricultural land quality**

7. It is suggested that, if following the assessment methodology used in earlier stages of the MCC land evaluation, the presence of land in active farming use should have led to the land at Dancing Hill and at Langley Close to be removed from the assessment at Stage 2 or earlier.
8. Having reviewed the RAG assessment for both sites they currently have tenants who use the land for agricultural process and that re-development of the land will require serving of eviction notices. This will result in not only loss of agricultural land contrary to both the Planning Policy Wales and the adopted Local Plan but also loss of livelihood to the tenants.
9. Separately, the Planning Policy Wales identifies that agricultural land of Class 1, 2 and 3a should be protected and this should be considered within the local development plan. Presumably, this should also apply to the allocation of Gypsy and Traveller Sites with the local development plan.
10. A consideration of the potential loss of Best and Most Versatile Agricultural Land is a key criterion in Stage 3A of the Candidate Sites Assessment but is absent from the MCC Land Evaluation for Gypsy and Traveller Sites. It would be appropriate to consider the loss of this resource in the land evaluation alongside the presence of active farming activities on land under consideration.
11. Land at Langley Close is considered to contain best and most versatile agricultural land, designated as Class 3A (Good Value). There is a presumption within the Planning Policy Wales against loss of agricultural land, which is also reiterated in paragraph 6.2.25 of the Adopted Local Plan. Specifically, the ALP requires that agricultural land is protected from inappropriate development. Clearly non-agricultural built development fails the obligations of both the PPW and ALP.

### **Reported feedback from RAG assessment of shortlisted sites**

12. The 19 July 2023 MCC Scrutiny Committee Report on 'Meeting Gypsy and Traveller pitch needs – land identification' includes a table of sites after paragraph 3.3. The summary/main conclusion for the Langley Close site in this table indicates 'no significant feedback received to suggest the site's suitability shouldn't be considered further'.
13. In fact, clear concerns are raised in the RAG over the placement of Gypsy and Traveller pitches in proximity to the M4 motorway on both the Langley Close and Dancing Hill Sites (on noise and air quality grounds). Additional objections to Dancing Hill are raised by the EHO in relation to introducing human receptors onto the old landfill site. On Ecology, there are clear recommendations within the RAG Assessment to not proceed further with this site. At Langley Close, there are also concerns about ecological impacts.
14. In short, the summary of RAG assessment significantly underplays the constraints on Langley Close and on Dancing Hill. At Dancing Hill, to address some constraints would appear mutually exclusive, for example addressing concerns about amenity (leading to considering of a buffer between new development and existing residents to the south, and health (leading to not developing gypsy and traveller pitches right next to the motorway to the north). The site is only 90m across from the boundary of adjacent houses to the motorway hard shoulder. This is before ecological corridor and important hedgerow (which bisects the northern part of the site) considerations come into play.
15. At Langley Close, similar conundrums are present. The site is an irregular shape, dissected by 2 ancient hedgerows which split the site into 3 smaller sites. This reduces the useable space in the eastern triangle to 1.72 acres, the western area to 1.9 acres and the northern area to 0.24 acres. Much of the Langley Close site is within 50 metres of the M4 motorway. At the narrowest point, the site is 50 metres from neighbouring houses to the tree buffer and the Junction 23 off slip. The creation of any buffer would render much of the site unusable. A new on-site access road will reduce useable space further. There are also setting considerations for the nearby listed buildings, a similar requirement to locate away from existing housing and yet also

away from the M4 motorway adjacent and ecological constraints which are part of the same issues raised at Dancing Hill – these two sites exist within an open nature corridor between the built settlement of Magor and Undy, and the M4. Development within it will compromise its function. Langley Close site is also located around 70m from a local SINC. Proximity to the SINC along with the other constraints ought to have seen the sites removed at an earlier decision point.

16. Whilst marked green in the RAG, the Langley Close site is 1km from shops, schools and community facilities – the bus service is infrequent. Access considerations for the suitability of Candidate Sites in the call for sites exercise revolve around reducing the need to travel to access essential services. 1km is considered too far for regular walking trips to access essential services on a daily basis. Whilst the site at Dancing Hill is closer to town (around 700m, at the more distant end of a walkable neighbourhood) this has a gradient.
17. The RAG shows both sites as designated DES2 amenity land. Development within these locations is not supported. This is a matter of principle and should be sufficient to remove the sites from consideration.
18. Travelling Ahead comments in the RAG rejected the Dancing Hill site on grounds of proximity to the M4 and to existing residents. Comments on Langley Close raised concern over the proximity of the site to the M4.
19. In summary, it should be evident from the RAG alone that significant doubt exists over the viability, deliverability and sustainability of the Langley Close and Dancing Hill sites such that it would seem prudent to exclude them from further consideration. The starting point for any potential application on the sites would be subject to these significant doubts and requiring costly technical assessments for significant matters including land contamination, air quality, noise, ecology, highways, landscape and heritage. Potential mitigations (should these be considered possible are likely to be costly, eg for site remediation, noise impact mitigation, landscaping and access works.

20. Some of the matters raised in the RAG and discussed above are explored in more detail below to illustrate the significant barriers to delivery of a development on the sites at Langley Close and Dancing Hill.

### **Noise Conditions**

21. The noise conditions likely to exist at the Langley Close and Dancing Hill sites can be illustrated through review of technical reports submitted in support of the approved development of 155 dwellings at Vinegar Hill (DM/2019/01937) is located adjacent to the M4 motorway, 150 metres to the east of the site at Dancing Hill. An Environmental Noise Assessment was submitted to discharge conditions 25 and 40 of the planning permission (in relation to parcel B). This indicated that environmental noise conditions arising from M4 motorway traffic (based on a 2018 noise survey undertaken for the original application) were between 60.2 and 61.1 dB during daytime hours (07:00-23:00 hours) and between 56.9 and 58dB during night-time hours (23:00-07:00 hours) at a survey position approximately 90 metres from the motorway – a 3db difference between daytime and night-time. (The 90m distance approximates to the distance between the southern boundary of the Dancing Hill Site, to the hard shoulder of the M4 Motorway to the north).

22. According to British Standard 8233:2014, noise levels inside living rooms should aim (there is a 5dB leeway) to be no higher than 35dB during the daytime period and no higher than 30dB in bedrooms during the night-time period, so surveyed noise levels were well above acceptable levels. However, through modelling of noise levels, the noise attenuation effects of three-dimensional buildings and structures were considered, as were the noise attenuation properties of building facades. For the nighttime, if an open-window would produce higher noise levels inside bedrooms, then acoustic glazing and trickle vents to provide air-flow could be incorporated into building design and this was considered to be acceptable.

23. Noise levels in outside garden spaces should not exceed 50dB – the effect of noise attenuation through the development orientation and layout ensures can be achieved (though some leeway is allowed in guidance for the 'convenience and

benefit' of living next to a motorway, the implication being that there are all sorts of services and facilities which go along with strategic transport infrastructure that make this a consideration worthy of living with more traffic noise).

24. The above process through which a seemingly difficult noise environment can be made to work for a development would be much harder to address for a gypsy and traveller accommodation site next to the M4 motorway. This is simply due to many of the development characteristics of a housing site being absent – there is not an extensive fixed layout of substantial 3D Structures to dampen and absorb noise – caravans are not fixed but come and go. The noise attenuation abilities of caravan facades are significantly lower than traditional houses. The design mitigations required to make internal noise levels in bedrooms during the night-time cannot be controlled through a planning permission as the caravans are likely to already exist and may not possess the required features – the noise environment has to be suitable without caravan design mitigation. Finally, people living in caravans (which is small accommodation in terms of available internal floorspace) tend to live life outdoors to a greater extent and so the treatment of noise in outdoor spaces becomes more important.
25. In order to achieve a suitable separation from adjacent housing on both Dancing Hill and at Langley Close, it is highly likely that development would need to occur closer to the motorway.
26. In summary, sites adjacent to the M4 motorway should not be considered suitable for Gypsy and Traveller Accommodation owing to a negative noise environment which cannot be mitigated through building design and owing to the operational aspects of such sites which create more exposure of site users to high levels of noise.
27. Noise impacts should be indicated as a 'red' in the RAG assessments of the Langley Close and Dancing Hill site. It is contended that further survey work would only confirm this position or at best indicate an extremely marginal noise environment position which, in the forward planning of gypsy and travellers sites, should not be considered further. There is

significant noise pollution risk and both sites are highly likely to fall into Noise Exposure Category C or D (TAN 11). This means that planning permission for residential dwellings should not normally be granted (C) or should be refused (D).

### **Air Quality**

28. Previous modelling to assess the impacts of the consented development at Vinegar Hill assessed the impact from existing traffic and from proposed development in relation to emissions for NO<sub>2</sub>, PM<sub>10</sub>, or PM<sub>2.5</sub>. One property on Grange Road (Receptor 2) was located approximate to the northernmost part of the Dancing Hill site, across the road to the east. With development and sensitivity variables factored in, this location was shown in the range 36.5µg/m<sup>3</sup> to 39.2µg/m<sup>3</sup> in relation to the annual mean objective of 40µg/m<sup>3</sup> for Nitrogen Dioxide. A further receptor (receptor 3) located to the south along Grange Road approximated to the southern extent of the Dancing Hill sites and emissions levels projected here were lower.
29. The Welsh Government has set objectives to lower air pollution and this means reducing impacts from development to levels well below Air Quality Objective levels, given the potential for negative health effects to occur even with lower emissions. Active forward planning of allocation of sites should ensure that sites that would introduce sensitive human receptors in locations with air quality conditions close to the Objective Levels are not considered further.
30. The assessment at the above site was based on predicted traffic for 2018 projected to 2021 and through the decade. Air Quality Assessment outcomes in relation to existing receptors (such as the Dancing Hill site) in this location are highly sensitive to traffic levels on the M4. Since 2018, significant events have occurred with relevance to traffic flows on the M4, including the COVID-19 Pandemic (which might reduce or alter flows as more people now work from home) and the removal of tolls on the Severn Bridge (which it is predicted have boosted traffic flows going over the bridge).
31. At this stage of consideration, further work to assess air quality would be required to determine whether any development



can take place at Dancing Hill and Langley Close given the potential for impacts on health to arise from traffic on the M4. Air Quality impacts should be indicated as red in a RAG Assessment of this site.

### **Site Access, access routes and proximity of services**

32. The Dancing Hill Site would be accessed from Grange Road. At present there is a gate providing access off Grange Road into a northern field separated from the southern field in the land parcel by a hedge. There is no formal access from Grange Road through the gate and this location would be unlikely to be considered acceptable given its position to the north of the site close to the bend.
33. The road leading up to the site at Dancing Hill has priority given to northbound traffic – the road is narrow between existing housing. Access to the site would be from a southerly direction through the narrow section of road. Other routes via Grange Road require the use of narrow country lanes for onward travel to the wider main road network. Going south, Grange Road turns into Dancing Hill which connects with the B4245, providing a route into Magor and out to the wider road network east and west.
34. The suitability of the route to the site, and the potential for the creation of a workable access into it, will depend on the scale of proposed development and traffic generated from this. There is a question mark over suitability of the upper part of the route approaching the site, for regular use by vehicles towing caravans.
35. The same roads south provide a pedestrian route across the B4245 to the village centre and local schools, around 600m to the shops and pubs and 700m to the schools. The route runs downhill to town centre and uphill to the Dancing Hill Site. The gradient might discourage cycling to and from the site. The site is toward the limits of what would be considered walkable on a daily basis.
36. The site is located outside the settlement edge of the village, close to the motorway. There are immediate neighbouring houses, but the overall position is that the site is relatively

distant from local services when the gradient of the hill is considered as a potential barrier to movement on foot or by bicycle.

37. In vehicle access terms, with regard to road routes to and from the site to the wider road network, these exist in one direction and are technically constrained for caravans near to the site. The access route should be regarded as Red in a RAG assessment.

38. Access to services is at the limit of acceptability for walking given the topography and should be regarded as Yellow also in a RAG assessment.

39. Access to the Langley Close Site would require a new access from St. Bride's Road, necessitating the removal of ancient hedgerow. St. Brides Road is narrow and a single-track road adjacent to the proposed site for allocation. In relation to the possible allocation for a Travellers site, guidance prepared by the Welsh Government titled "Designing Gypsy and Traveler Sites" states that access road to the site should be at least 5.5m and be able to accommodate vehicles of up-to 10m length. St Brides Road does not meet these requirements. Welsh Government guidance also states that a footpath of at least 0.9m wide is required. This is absent from the Langley Close site. Therefore, the Langley site fails to achieve minimum access requirement provided by Welsh Government and should be screened out. It is understood that this is consistent with the consultation response given by the Traveller Community via the People Scrutiny Committee. The Council's Highways Engineer has stated in the RAG Document that the development at Langley Close will have a significant impact on the safety and capacity of the immediate local network, the existing access is unsuitable and a new access to the site will need to be created. Access limitations for both sites fail the obligations under Policy H8 of the ALP.

40. Whilst there is an existing stub off St Brides Road this appears to connect to residential gardens and a new access will be required. St Brides Road is on a bend at this point with no real opportunity for creation of a suitable visibility splay to allow safe access and egress from vehicles entering Magor from the North.

### **Leisure Corridor**

41. The Dancing Hill and Langley Close sites are located within a buffer of undeveloped land running between the northern edge of Magor and Undy and the M4 motorway. The Dancing Hill site is located at a point where the buffer connects to woodland running south through Magor. Land further to the east was also buffer, but is now under construction for housing.
42. The designated public footpath network in the area has a missing link across the Dancing Hill site, needed to make a connection from footpaths to the west with those to the east, across the northern edge of Magor and Undy. The Dancing Hill site crossed by walkers to continue a west-east, using paths which are not formally designated public rights of way.
43. Development of any kind at this location has the potential to disrupt the site's function in facilitating a leisure corridor and connection.
44. The Monmouthshire Green Infrastructure Strategy (2019) recognises the range of scales and connectivity through which green infrastructure functions and is provided. At neighbourhood scale, important green infrastructure resources include amenity greenspaces (such as land designated under policy DES2) and urban woodlands (such as that extending into the heart of the settlement from the Dancing Hill site and wider buffer gap to the north of the settlement. Important connections include pedestrian paths and rights of ways, green links and corridors, such as those provided at and through the sites at Langley Close and Dancing Hill. The development of these sites would impact on functioning, designated green infrastructure resources important to the local community.
45. The function and value of land south of the M4, sitting between it and the edge of Magor, is already recognised in the adopted local plan. Policy DES2 designates areas of amenity importance. These are designated in recognition of the value of land in providing amenity space where it might otherwise be lacking.

46. DES2 sets criteria for development to be considered acceptable within Areas of Amenity Importance. The policy states that there should be no unacceptable adverse effect on any of the following:

47. ***Visual and environmental amenity of the area, including important strategic gaps, vistas, frontages and open spaces.***

The Monmouthshire Landscape Sensitivity and Capacity Study (Oct 2009) identifies both the Dancing Hill site and the Langley Close Site within Site MA05. The candidate sites are part of an important buffer (gap) between the settlement and the M4 motorway. Dancing Hill site is in a narrow gap between the settlement and the motorway and is elevated providing a vista from the west to the east and from the settlement edge. Development of the site would intrude into this vista. The Langley Close site is considered to be high to medium sensitivity owing to its more positive relationship between the settlement and the countryside, afforded by public rights of way links. This would be highly sensitive to development. Landscape sensitivity might be considered medium directly adjacent to the motorway, but then this would be unacceptable from an amenity and health impacts perspective. An update to the above assessment was carried out in 2020 and this confirmed the sensitivity of the areas discussed to new development. It said that should development be considered, the mitigation discussed would involve significant and heavy screens of tree planting. It is contended that this would remove one of the essential features of this area which is the vistas it affords. This would be a significant disbenefit to users of this important amenity area.

48. ***The relationship of the area of amenity importance to adjacent or linked areas of green infrastructure in terms of its contribution to the character of the locality and/or its ability to relieve the monotony of the built form.***

If development intrudes into the gap between the settlement edge and the M4 motorway to the north of Magor and Undy then an essential rural village characteristic of the settlement will be eroded and lost. Without the gap, development will spread to the M4 motorway, providing a hard unpleasant edge to the settlement which currently is buffered by agricultural land for the most part. Access to countryside to the north will only be possible by travelling under or over the M4 in a few places.

Bearing in mind that the railway to the south of the settlement severs Magor and Undy from the levels to the south, access for local people to amenity areas and countryside is already constrained. For this reason, development in the countryside to the north of the settlement should be avoided.

49. ***The role of the area as a venue for formal and informal sport, general recreation and as community space, expressed in terms of actual usage and facilities available as well as its relationship to general open space requirements as set out in policy CRF2.*** The sites at Dancing Hill and Langley Close are within an area which is extensively used for walking via formal public rights of way and informal pathways. These link the settlement to the countryside and provide opportunities for users to experience views and vistas and escape the urban settlement without crossing the motorway. The dancing hill site sits at an important fulcrum of paths extending west and south. The site affords east west informal walking paths. Development of the site would adversely impact this important resource. The Langley Close site is more sensitive to development for the same reason in that the site provides a positive link between settlement and countryside as identified by the landscape sensitivity and capacity study.
50. ***The cultural amenity of the area, including places and features of archaeological, historic, geological and landscape importance.*** The Langley Close site lies within the setting of a listed building and both this and the Dancing Hill site are identified as have high to medium sensitivity to new development in landscape assessment terms, as discussed above.
51. ***The nature conservation interest of the area, through damage to, or the loss of, important habitats of natural features (policy NR1 applies).*** In response to the RAG assessment, the ecology officer from Monmouthshire County Council has raised concerns over both Langley Close and Dancing Hill in terms of the impacts of development of these sites on wildlife and habitats. This is discussed further below.
52. It is noted that the RAG Assessment proposes to remove DES2 Area of Amenity Importance status from the Langley Close and Dancing Hill sites. From a local community perspective it is

not clear how or why the existing designated area of amenity importance can be considered to be less important than it was previously, to a degree which would remove these policy protections and actively promote development within the area.

### **Ecology and Wildlife**

53. Should the sites be developed, the new access will be required with loss of existing trees and hedgerows. The removal of the ancient and ecologically rich hedge will cause environmental damage and fails the obligations under Policy S13 of the Adopted Local Plan.
54. Both sites contain areas of trees and woodland which can support wild life. In addition, their greenfield nature and location creates a green corridor which supports and allows movement of wildlife so creating a green corridor between the M4 Motorway and the urban development of Magor and Undy.
55. Ecological Connectivity Assessment of Settlements in Monmouthshire Report produced by Gwent Ecology looked at opportunities to strengthen existing habitat connectivity. Including Pg 42 paragraph 2) "Strengthen the St Brides Brook Mill Reed Corridor, the main semi natural corridor through the urban zone of Magor and Undy". This will be further eroded by the proposed development not improved.
56. Monmouthshire County Council declared a Climate Emergency one of the key actions is to embed biodiversity throughout decision-making; reduce key pressures on species and habitats; supporting landscape scale nature recovery projects and partnerships to enhance ecosystem resilience. Construction of built development on either site contravenes these obligations and commitments.
57. Policy GI 1 of the Adopted Local Plan requires planning to maintain, protect and enhance green infrastructure networks. There are also requirements within Planning Policy Wales to providing resilience in the eco system, halting and reversing loss of biodiversity, management and enhancement of green

infrastructure. Construction of built development on either site contravenes these obligations.

58. The proposed allocation of the site for built development risks damage to nature conservation interest of the area, through damage to, or the loss of, important habitats or natural features and is therefore contrary to policy NE1 of the Adopted Local Plan.

### **Neighbours and Amenity**

59. The Dancing Hill Site has neighbouring residential properties along the southern boundary, and across Grange Road to the east in the northeast part of the site. The Langley Close Site is an irregular shape and is bounded on four sides by residential properties on St. Brides Road, Langley Close, Newport Road and by Grade 2 listed Woodland House. Given the matters raised about the strong potential for noise impacts and air quality impacts on the occupants of both sites, it is highly likely that, should either site be developed for Gypsy and Traveller accommodation, the need for a buffer between the development and the M4 might compromise land use and a suitable landscaped buffer from existing residential development.

60. We understand that the identification of sites and progression of proposal to potential site allocations for Gypsy and Traveller Sites should be undertaken in consultation with the Gypsy and Traveller community. In this instance, we understand that consultation has taken place and that the response from the Gypsy and Traveller community was that neither the Langley Close site were considered suitable owing to the poor noise and air quality environment and because of proximity to neighbouring development. Whilst the issue of proximity is difficult, because a clear aim in policy is to improve integration and reduce isolation in these communities, the response from the Gypsy and Traveller community in these cases indicates significant environmental constraints with the sites, potentially perceived to affect health. The response also indicates a concern about exposure of the sites to potential conflict in land uses (referring to the role of this land in providing a buffer and leisure walking routes).

61. The noise and environmental conditions are likely to result in a need to place the development in the areas furthest from the motorway, close to existing homes. A significant buffer may not be possible.

### **Conclusion**

62. Whilst the need to identify sites for gypsy and traveller accommodation is recognised, the identification of sites at Dancing Hill and Langley Close are considered to be ill-suited for the purpose, because they are too close to the motorway, giving rise to significant potential amenity and health concerns. Any mitigation of such impact (considered that these would be unsuccessful would in any case rely on moving the development closer to existing residential development and to other receptors (listed building). Development in these spaces would intrude into sites which are used for leisure and recreation purposes and cause landscape sensitivity impacts. Development in an important buffer to the north of the settlement will erode it and lead, eventually, to the settlement extending to the edge of the motorway. Site accessibility by vehicles is constrained by the local road networks. One site is a former landfill with potentially significant remediation requirements. From a constraints perspective, these sites are significantly constrained and there is a low level of likelihood that these can be overcome through technical assessments and mitigation measures.

63. Apart from this, both sites are considered isolated from local community surveys through a combination of distance (1km from Langley Close site to local schools) and topography (Dancing Hill is elevated and 700m distant from the school). Public transport is limited to an infrequent local bus service.

64. Magor with Undy Town Council strongly recommend the removal of sites at Langley Close and Dancing Hill from further assessment and consideration, so that they remain free from development and retain their important functions.



<p>Portskewett Community Council</p> <p><b>Feedback form</b></p>	<p><b>On Bradbury Farm and Oak Grove Farm's disadvantages:</b> The site would be adjacent to a busy road and there are no footpaths or cycle paths near the site. There is no public bus service which could service the site. Current infrastructure i.e. school, doctors, dentist, in the area are already oversubscribed. There are no shops near the site, Caldicot town being the nearest, to which access would be difficult given the lack of bus service and safe walking/cycling routes. A large housing development is planned near the site which wouldn't be akin to the rural environment normally preferred by gypsies/travellers.</p> <p><b>Further comments:</b> "The current provision of gypsy/traveller sites in Monmouthshire are in Portskewett, other areas of Monmouthshire are lacking provision. By locating all sites in the south of the county no choice is being offered to gypsies/travellers who may prefer to be located in other areas within Monmouthshire."</p>
<p>Caerwent Community Council</p> <p><b>Email</b></p>	<p>Crick is a small hamlet with just over 60 houses. Crick falls within the Ward of Caerwent Community Council (CCC) but the Bradbury Farm site which is within a few hundred yards of Crick falls under Portskewett Community Council due to the electoral boundaries. In view of this we feel it is appropriate to comment on the two proposed traveller sites at Bradbury Farm Crick and Oakgrove Farm at Leechpool which would directly affect the residents we represent.</p> <p>Please see our concerns below:-</p> <p><b>1. Clustering of Traveller Sites</b></p> <p>The hamlet of Crick currently has one private traveller needs site with a park home and multiple static and touring caravans with associated vehicles. This is on the boundary of the hamlet of Crick, is less than 100 yards from a Grade 2 listed building and lies within the village boundary as defined by the 'Crick' road sign on the A48. The proposed Bradbury Farm site would lie within a few hundred yards of the hamlet on Crick Road. There is no mention of this pre-existing traveller site in any of MCCs documentation, (RAG) Report etc. It seems unusual that the small settlement of Crick should be put into the position of having two traveller's sites 0.3 miles apart, both immediately adjacent to it and lying on two of the three roads entering the hamlet. One Crick property will look from their front garden, across the A48 into the existing traveller site and, if it</p>

proceeds, from their back garden across a single field to the proposed Bradbury Farm site.

In addition, there is a second pre-existing site for travellers needs already further up Crick Road 0.3 miles from the proposed Bradbury Farm site (and 0.8 miles from the proposed Oak Grove site).

It is unclear why MCC are proposing to cluster traveller sites in this way. Welsh Government guidance that clustering such as this can lead to problems.

## **2. Road and Pedestrian Access**

The Bradbury Farm site lies on an S bend of Crick Road, and it is difficult to see how this is considered a safe access point for a multi occupancy site given the limited visibility, even with a reduction from the current unrestricted speed limit. A local resident in a nearby house was told by MCC it would not be safe to have a driveway opening on to Crick Road near this point.

The Oak Grove site would open onto the B4245 another busy road.

Neither site has suitable pedestrian access. It is suggested that this will follow future development as planned with the RLDP, but this may take some considerable time for this to be taken forward, yet we are told these traveller sites are needed as a priority. So, the sites either must be delayed or will not have safe pedestrian access, street lighting, etc and residents from the 2 sites will be reliant on their vehicles for travel. Active Travel would be dangerous, especially for children.

## **3. Amenities**

Crick has no shop or other public amenities for residents of the Bradbury Farm site to use or to act as a means to integrate into the settled community. The bus service is very limited, and the development of a site is not likely to lead to any change. Crick does not have any mains drainage.

Oak Grove Farm is also a long way from any local amenity.

## **4. Health and Wellbeing of Travellers**

The Bradbury Farm site is adjacent to the M48 with resulting noise and air pollution.

## **5. Impact on Character and Appearance**

	<p>The proposed site at Bradbury Farm along with plans in the RLDP will significantly change the nature and character of the hamlet of Crick.</p>
--	---

	<p>The Oak Grove site will have a negative visual impact, including at night, with the area being highly visible including from the A48.</p>
--	--

## Other stakeholders

7.2 Responses were provided from relevant persons relating to external organisations.

- A local sports club.
- Road Chef, Magor.

# 8. Feedback from the Gypsy & Traveller community

---

8.1 According to the data, **two feedback form submissions** were provided by those who identified as Gypsy & Traveller.

8.2 Key feedback raised:

- Both agreed to the Council's vision, acknowledge that safe sites were needed and were supportive of the process.
- Both raised concerns that Langley Close site was too close to other homes and the motorway.
- Both agreed that Bradbury Farm and Oak Grove Farm were 'nice' site locations as they offered lots of space.

8.3 It is possible further responses may have been received from the Gypsy & Traveller community, but their identify was not disclosed on their feedback forms.

8.4 **Two additional verbal responses were received.** One Gypsy and Traveller provided feedback by phone, pledging support to the proposals and all three sites and one welcomed the Council's proposal to identify potential sites.

# 9. Feedback from survey responses

## Who responded to survey?

9.1 This section of the report gives an overview of the demographic of respondents in comparison with the local and national statistics from the census data. The feedback form is to help determine whether the engagement is in line with the local community. See below map of the locations considered for this:

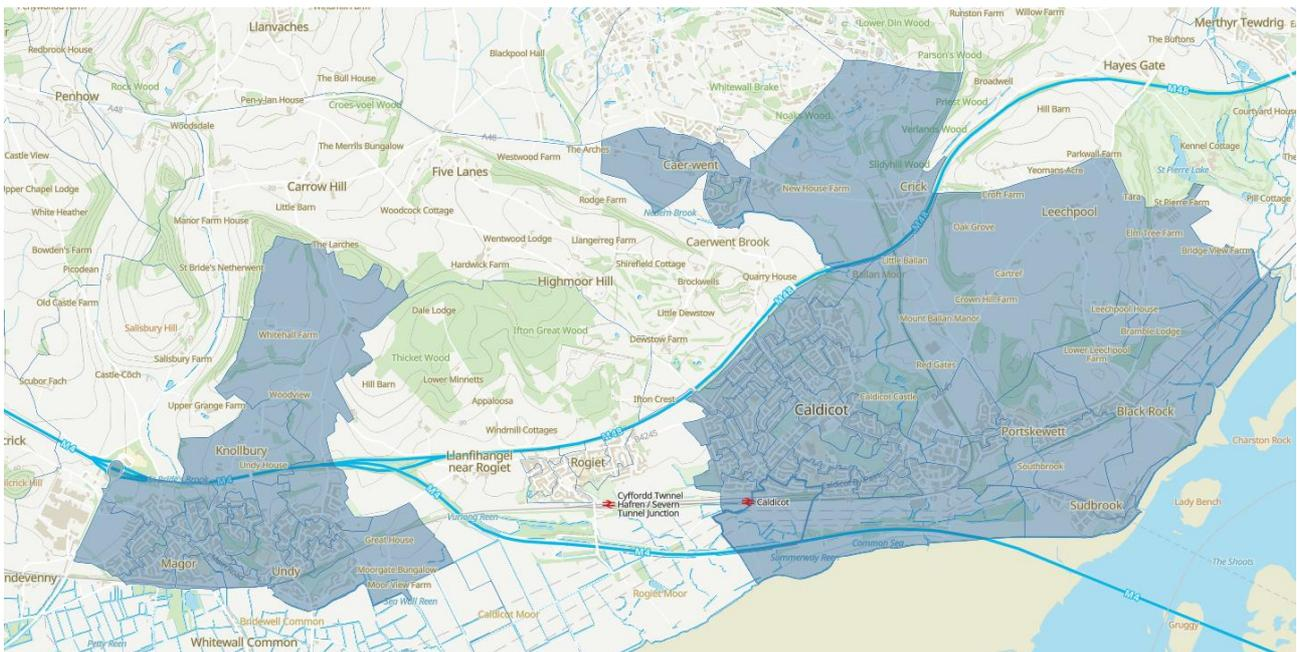

## Age

9.2 A total of 381 of 389 respondents provided an answer to what age group they belonged with, 23 of whom chose 'prefer not to say'. Those who were above the age of 55 were the most active in terms of feeding back (192) compared to those who were younger (166). A significantly higher percentage of people in the 55-64 age group contributed to the consultation compared to the local community average.

Option	Total	Total %*	Local community average %
0-15	0	0.0%	16.3%
16-24	6	1.7%	9.6%
25-34	46	12.9%	11.7%
35-44	64	17.9%	11.1%
45-54	50	14.0%	13.9%
55-64	97	27.1%	14.7%
65+	95	26.5%	22.6%
Prefer not to say	23	-	-
<b>Total</b>	<b>381</b>		

\*=Percentages exclude 'Prefer not to say' figure.

## Gender

9.3 A total of 379 of 389 respondents provided an answer to what age group they belonged with, 18 of whom chose 'prefer not to say'.

Option	Total	Total %*	Local community average %
Female	179	49.6%	51.3%
Male	182	50.4%	48.7%
Other gender identity	0	0%	0%
Prefer not to say	18	-	-
<b>Total</b>	<b>379</b>		

\*=Percentages exclude 'Prefer not to say' figure.

## Ethnicity

9.4 A total of 380 of 389 respondents provided an answer to what ethnic group they belonged to, 19 of whom chose 'prefer not to say'. 97.2% of respondents reported themselves as White: Welsh, English, Scottish, Northern Irish, British or Other, which is nearly in line with the local community average.

9.5 Please note: Table below shows the ethnic identities of those who contributed to consultation.

Option	Total	Total %*	Local community average %
<b>White: Welsh, English, Scottish, Northern Irish, British and Other</b>	351	97.2%	97.3%
<b>White: Gypsy, Roma or Irish Traveller</b>	2	0.6%	-
<b>Asian, Asian Welsh or Asian British</b>	2	0.6%	1.0%
<b>Black, Black British, Black Welsh, Caribbean or African</b>	0	0.0%	0.1%
<b>Mixed or multiple ethnic groups</b>	2	0.6%	1.3%
<b>Other</b>	4	1.1%	0.2%
<b>Prefer not to say</b>	19	-	-
<b>Total</b>	380		

\*=Percentages exclude 'Prefer not to say' option.

9.6 Statistics above do not include Black, Black Welsh, Black British, Caribbean, or African (0.9% of the Welsh population) as they did not submit feedback to this consultation.

## Disability

9.7 A total of 379 of 389 respondents provided an answer to what age group they belonged with, 24 of whom chose 'prefer not to say'. A higher percentage of those without a disability contributed to the consultation compared to the local community average.



Option	Total	Total %*	Local community average %
Yes	25	7.0%	18.3%
No	330	93.0%	81.7%
Prefer not to say	24	-	-
<b>Total</b>	<b>379</b>		

## Location

9.8 Of the 389 survey respondents, 367 provided their postcode in full, 307 (84%) of whom were from the postcode areas of NP26 3 (local to Langley Close) or the postcode areas of NP26 5 (local to Bradbury Farm and Oak Grove Farm). Feedback was also provided from a number of people residing away from Monmouthshire, notably in Cardiff, Bridgend, Ebbw Vale, Bristol, and Ascot in Berkshire.



**Figure 1: Pinpointed postcodes of all survey respondents who shared this information.**

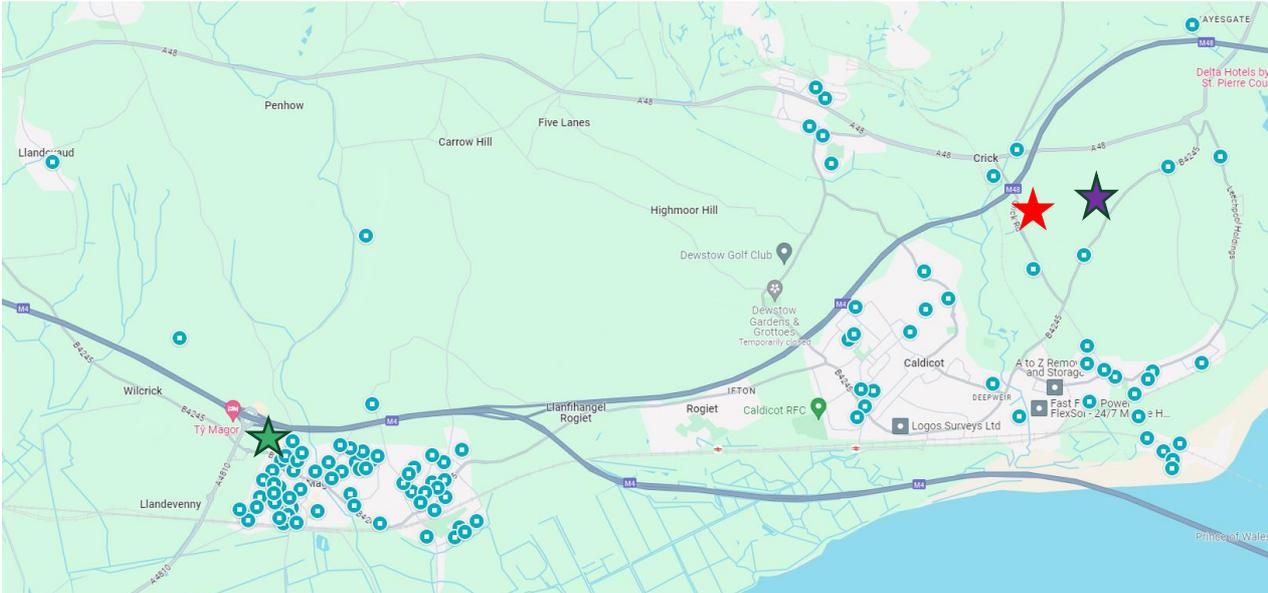

★ **Langley Close**

★ **Bradbury Farm**

★ **Oak Grove Farm**

**Figure 2: Pinpointed postcodes local to proposed site locations**

9.9 **Please note:** These pinpoints do not point to specific properties, but the centre of a given postcode.

## Feedback on the Gypsy and Traveller sites

9.10 This section of the report sets out a summary of the responses from the feedback form and emails in relation to the three proposed sites.

9.11 We have discounted any individual feedback which contains discriminatory language or stereotyping towards the Gypsy and Traveller communities. This was clearly stated at the start of the consultation process on the feedback form.

9.12 It is also worth noting that much of the feedback provided for all the sites are replicated from materials and notes created by campaigners who are against the proposals.

## Langley Close

9.13 **Advantages/strengths – 53 responses, summarised below:**

- It is very close to the community to which could give Gypsies and Travellers the opportunity to integrate more with society.
- Within walking distance of local amenities.
- Active travel and community engagement will be possible.

- Off road isn't as busy as the two locations proposed in Crick, so risk is reduced.
- While also seen as a disadvantage, feedback suggests that its close proximity to the M4 is also an advantage, so that trailers can easily access the motorway.
- Some have expressed preference of sites that aren't in Caldicot, so prefer Langley Close site for that reason.
- It is a council-owned site not being used or occupied.
- Plenty of open land and not too much development expected residentially.
- The site is nearer to mains electricity and mains sewage therefore would require less infrastructure and money to make the area suitable.
- The visual impact of the site is much lower than the other two proposed sites.
- The area is surrounded by a tree belt to give both communities privacy.

#### 9.14 Disadvantages/weaknesses:

##### **Principle of location – 126 responses:**

- Manson Heights and Mitchel Troy sites were removed on grounds of access. There are however significant accessibility challenges for the proposed Langley Close site. The site exits on to St Bride's via a blind bend on to a heavily trafficked, national speed limit narrow country lane that lacks footways.
- This is a greenfield site. It has an important biodiversity which should be respected and cared for.
- The Council's Highways Engineer has stated in the RAG Document that the development will have a significant impact on the safety and capacity of the immediate local network.
- Some respondents mistakenly suggested that the site was used for sustainable farming and food production and is part of the Council's local food initiative.
- ...

##### **Green and open spaces – 111 responses:**

- This is one of the last remaining Magor with Undy green open spaces, forming a buffer between the current residential developments and the M4. Reinstating the Public Right of Way (PROW) from Dancing Hill westwards and across the Langley Close site to join the existing PROW to the west of the site would provide much needed recreation space, including dog walking. The latter point is particularly important if the community field at Sycamore Terrace is taken away by MCC and given to Magor CIW primary school as a school field,

as residents would not be able to let their dogs off the lead or use this space for safe dog-walking (as is currently used).

- There was concern that the current tenant of the land would potentially lose their licence, which may detrimentally impact on the tenant's income and family.
- There is a misunderstanding that the tenant produces sustainably sourced local food for the local community on this land.

#### **Traffic and road safety – 102 responses:**

- There is also only one road in and out of Magor and Undy which comes to a standstill any time something happens on the motorway or when local bridges are closed.
- The site is adjacent to the M4 motorway and raised slip road to Junction 23A.
- There are concerns about lack of footpaths/ narrow footpaths and poor visibility for all residents especially for children walking to/from school buses. This increase traffic will mean even more of a challenge for all pedestrians to navigate the roads safely.
- Visibility from the site is restricted and non-compliant with highway safety regulations.

#### **Noise – 153 responses:**

- Noise pollution levels are extremely high - exceeding 75 decibels on much of the site (any noise exceeding 70 dB is considered harmful and disturbing and could result in hearing loss over time).
- Noise and air pollution from the adjacent motorway would be detrimental to health and well-being and negligence to adhere to such issues would be a breach of the Council's duty. According to the Department for Transport, traffic has reportedly increased by 21% since the tolls were abolished.

#### **Impact on existing neighbourhoods – 146 responses:**

- The site backs onto many longstanding, existing houses and both sites would be overlooked. This would compromise both visual and acoustic privacy for both the current residents and Gypsy development.

#### **Scale of site and pitches – 46 responses:**

- The site is an irregular shape, dissected by two ancient hedgerows which split the site into three smaller sites. This reduces the useable space in the eastern triangle to 1.72 acres, the western area to 1.9 acres and the northern area to 0.24 acres. A new on-site access road will reduce this further. Unless the Council is intending to remove the ancient, protected hedgerows which contain

protected species, the remaining useable space will restrict the layout and density of pitches.

#### **Impact on views – 3 responses:**

- The gardens in Langley Close will be overlooked and the views of greenery we have had for years will no longer be there.

#### **Habitat loss – 138 responses:**

- The Council's Ecology Officer has stated in the RAG Document that the woodland along the M4 corridor is likely to support dormouse and other species that may be present include bats (including roosts in trees), reptiles and nesting birds. There is also evidence of other protected species, including badgers.
- Removal of tress and hedgerows to facilitate the site would not only jeopardise the Gypsy and Traveller community but also the existing residents.
- The site is dissected by ancient hedgerows protected under the Hedgerows 1997 regulations.
- The site is graded Best and Most Versatile (BMV) land. Only 10-15% of land in Wales is classified as BMV land. Planning Policy Wales states it should be conserved as a finite resource for the future.

#### **Pollution – 160 responses:**

- Gypsy families would face respiratory related health issues as the site is closely adjacent to the main M4 Motorway, air pollution levels are known to be excessive in this area.
- Possible landfill site and potential ground contamination.

#### **Flooding risk – 85 responses:**

- Uneven topography and concreted areas reducing natural soak-away pose a significant flood risk. The St Bride's Road is renowned for flooding, and this creates issues at every major downfall (See photos received in [Appendix 7](#)).
- The site is not level, particularly to the west. The current green field provides a natural soakaway for surface water, but excess water currently floods St Bride's Road. Concreting over areas will reduce the natural soakaway resulting in more surface water run off onto St Bride's Road and potentially flooding nearby properties.

#### **Impact on protected sites – 125 responses:**

- There is a Listed Building, Woodland House, situated only 40m from the proposed site.

- The site is within the Gwent Levels, only 70m from a Site of Importance for Nature Conservation (SINC) and only 700m from the Site of Special Scientific Interest (SSSI).
- The site lies within a Mineral Safeguarding Area.

**Property values – 2 responses:**

- Property prices are already starting to go down, we are worried it will get worse should proposals go ahead.

**Overdevelopment of area – 59 responses:**

- Magor with Undy is already overdeveloped, with a documented deficit of open green space. Part of the site is currently designated as an Area of Amenity Importance, yet the Council intend to remove this to allow development.
- It's difficult enough as is to register for healthcare facilities such as a local GP, not to mention a dentist, which I've still be unable to get locally after living in the area for a few years.
- Lack of Welsh language primary and secondary education. Considering Wales wants to increase the number of Welsh speakers within the country, it would be at a disadvantage to the travelling community to be in an area where there are little to no opportunities for them to attend a school through the medium of Welsh.

**Bradbury Farm and Oak Grove Farm**

9.15 Due to site locations being near to each other, feedback provided for Bradbury Farm and Oak Grove Farm were similar and therefore grouped in this report.

9.16 **Advantages/strengths – 87 responses, summarised below:**

- Further away from the M4 so therefore the area has better noise level and air quality compared to the proposed Langley Close site.
- The site retains good access to public transport and has easy access to Caldicot and a range of local services.
- That stretch of the A48 was a Traveller's route hence Travellers know this area probably better.
- Monmouthshire County Council own the land.
- Remote location on a quiet stretch of road.

- It is far enough away from existing dwellings as the Traveller community prefer not to be adjacent to existing houses.
- It is a flat/level site.
- This site is also surrounded by hedgerow and fencing giving the tenants privacy.
- Crick is a small village with ample green space to share. Giving up part of an existing farm is more suitable if the village is not opposed to the change of use of this land.
- Developing there would have little impact on ecology and wildlife compared to other site plans.
- Site not near to existing local anti-social behaviour.

#### 9.17 **Disadvantages/weaknesses:**

##### **Principle of location – 60 responses:**

- It enables Monmouthshire County Council to identify a site with minimum effort by simply tagging onto the RLDP, rather than working to identify the best sites in Monmouthshire.
- There are sparse amenities within walking distance.

##### **Green and open spaces – 16 responses:**

- The proposal will result in the loss of publicly owned agricultural land and green spaces.

##### **Traffic and road safety – 123 responses:**

- There is no footpath which makes walking on the road very hazardous.
- Additional vehicles entering and exiting a future site on the road would worsen this situation.
- That stretch of the A48 cars can go as fast as 60mph. There have been 'near misses' of pedestrians almost being run over.

##### **Noise – 34 responses:**

- Busy roads in the proximity and noise from the nearby M48 motorway (even if it is a quieter motorway than the M4).

##### **Impact on existing neighbourhoods – 56 responses:**

- Too close to existing developments and the A48.

- Crick is a very small community with no amenities or services. The creation of additional residents will have a big impact on existing residents.
- More rural location making integration with the community more difficult.
- Fear of increased crime in the area, and with reduced police presence.

**Habitat loss – 6 responses:**

- We should not be using up green belt that we will need for food production for generations to come.
- We need greenbelt and farmland to assist with reduction of CO2 and net zero goals.

**Pollution – 38 responses:**

- The potential damage to land due to unlawful fly-tipping.

**Flooding risk – 7 responses:**

- A lot of water drains away from Ballan Wood.
- Crick area is prone to flooding.

**Tourism – 9 responses:**

- There were a number of discriminatory views expressed through the consultation. These comments have not been included and have been discounted.

**Property values – 10 responses:**

- Concern about house prices decreasing as a result of this development. Suggestion that community tax being reduced accordingly.

**Overdevelopment of area – 44 responses:**

- Crick already has two Traveller sites providing accommodation for 7/8 families. A further development provided for approximately 6 families will mean that a high percentage of the area is given over to Travellers and create an imbalance in population.
- The addition of a Traveller's site could rise local services being overstretched. They are already under pressure especially with the addition of the hundreds of homes under construction in the area.
- With the recent Enzo estate and Redrow in Sudbrook, the Lovell estate, and Nant y Castell in Caldicot, these are already adding a lot of numbers to the area.



- Recent developments in Portskewett and Sudbrook has already increased population with no amenities added such as shops, doctors, school, pharmacy, activities for kids, etc.

## Additional Oak Grove Farm comment

9.18 In addition to the above, the only comment which was clearly identified for Oak Grove Farm rather than Bradbury Farm is:

- This proposed site is not part of Oak Grove Farm, it is situated as part of what was Severn Farm and now farmed by the tenants of Parkwall Farm (**9 responses**).

## Other comments

- **Planning policy** - The proposal is in direct contradiction to a number of policies in the current LDP, for example, Policy DES2 - Areas of Amenity Importance.
- **Community cohesion** - If the idea is to integrate the gypsies and Travellers into the community and get the population to accept them, why hide them away from view at one end of town in an unsuitable site?
- **Geographic concentration of site** - Questions were raised about the justification of choosing sites in a small geographic area when Monmouthshire is a large county with lots of land potentially more suitable. There is a lack of parity for changes in the three market towns of Monmouthshire, namely Chepstow, Monmouth, and Abergavenny. The three main market towns are having to meet increasing demands in health, education, and road improvement budgets. The needs of Chepstow residents are relatively being treated differently.
- **RAG process** - There are concerns about the lack of detail in the RAG report for the proposed sites.
- **Consultation process** - Some have questioned the approach of being asked about multiple sites as the decision should be mutually exclusive and should not 'play one site off against another'. They consider this as unfair to those involved, and it could be perceived as being very divisive within a local community.
- **Consultation publicity** - Would like future consultations to be promoted using more traditional means rather than rely on social media and digital channels.
- **Alternative sites assessment** - The Council requested residents to send in ideas for alternative sites, yet the Council has not reported back on this. At least one resident sent into the Council a list of 11 alternative sites, five of which were brownfield and one underutilised council land.

## 10. Summary and next steps

---

10.1 This consultation report sets out the actions taken by Monmouthshire County Council to undertake the early-stage consultation both with key stakeholders and the community.

10.2 The level of feedback from this consultation has been high and very consistent, in terms of the number of people as well as what they have to say.

10.3 The most common themes fed back were:

- For Langley Close: pollution; noise; impact on existing neighbourhood; habitat loss; and principle of location
- For Bradbury Farm and Oak Grove Farm\*: traffic and road safety; principle of location; impact on existing neighbourhood; overdevelopment of area; and pollution.

*\* Due to site locations being near to each other, feedback provided for Bradbury Farm and Oak Grove Farm were similar and therefore grouped in this report.*

10.4 Feedback from this consultation will inform the Council's ongoing evaluation of the three sites in question and the next stage of the site identification process.

10.5 Running alongside the review of the consultation is site evaluation work of each of the three sites. External specialists have been appointed to undertake:

- Noise assessments
- Ecology assessments
- Land contamination assessments
- Air quality assessments, and
- Transport assessments.

10.6 The findings of these assessments will be considered by the Council's Ecology, Highways and Environmental Health teams who will be asked to make recommendations on the basis of the findings.

10.7 In addition, the Council is continuing to proactively engage with households who own private land about the possibility of obtaining planning permission for pitch provision.

10.8 The outcome of these three strands of work will inform a recommendation of whether any of the three sites are suitable to be recommended to Cabinet for inclusion in the emerging Replacement Local Development Plan. This recommendation will be reported to the Council's Place Scrutiny Committee

for initial consideration by elected members. Cabinet will then decide which site(s) will be included in the Replacement LDP Deposit Plan.

10.9 Further consultation will be undertaken as part of the Replacement Local Development Plan 2018 – 2033 Deposit Plan in 2024. There will also be further consultation as part of any future individual planning applications.

## Statement from the Council

10.10 The Council would like to pass on its thanks and appreciation to everyone who has shown an interest in the site identification process and who has provided comments and views about the suitability of the individual pieces of land at Langley Close, Bradbury Farm and Oakgrove Farm for possible future use as Gypsy & Traveller pitches.

# 11. Appendices

---

## Appendix 1 Consultation programme

### Project Programme



**Project** Gypsy, Roma and Traveller site identification consultation  
**Client** Monmouthshire County Council  
**Date** 12 October 2023

Dates	Actions required
13/10/2023	Prepare consultation plan and key messages, project risks
13/10/2023	Preparation of communications materials including press release, social media toolkit, poster and webpage content
16/10/2023	Organise consultation events
17/10/2023	Draft copy to client: press release, social media toolkit, posters
18/10/2023	Client review copy
19/10/2023	Finalise copy and issue for Welsh translation
24/10/2023	Launch of 6-week consultation: Issue press release and website live <ul style="list-style-type: none"><li>● Social media - Launch</li><li>● Social media to provide website update with exhibition material</li><li>● Social media to promote event 1</li><li>● Social media to promote event 2</li></ul>
22/11/2023	Event 1: Portskewett Church Hall, Portskewett,
23/11/2023	Event 2: Magor and Undy Community Hub, Major <ul style="list-style-type: none"><li>● Social media - thanks for coming give feedback</li><li>● Social media - deadline</li></ul>
05/12/2023	End of 6-week consultation
18/12/2023	Data analysis
20/12/2023	Consultation report drafted

## Appendix 2 Feedback form (paper)



### Monmouthshire County Council

### Gypsy & Traveller Site Consultation Form

Monmouthshire County Council (MCC)'s Gypsy & Traveller site identification process has identified three sites that the Council would like your views on. A public consultation for 6 weeks will run from **9<sup>th</sup> November 2023 to 22<sup>nd</sup> December 2023**. This is being run by [Grasshopper Communications](#) on MCC's behalf.

Please use this form to respond to the consultation using additional sheets as necessary. If you would like to provide further supporting information, please send this via email using the details below. The questions have been designed to inform the Council's continued evaluation of the three sites and their potential suitability for Gypsy & Traveller sites. Further copies of the form can be obtained from the Housing & Communities Team and the Council's website or you can photocopy this form.

The Council has a zero tolerance to the use of any racist, discriminatory or prejudiced remarks or feedback. Any such comments will not be included in the consultation and will be returned to the author.

### How to submit your response

To assist with the efficient processing of responses we would ask you to submit your comments electronically via the MCC website: <https://www.monmouthshire.gov.uk/gypsy-and-traveller-sites-consultation/>.

Alternatively, forms can be: emailed to [housingrenewals@monmouthshire.gov.uk](mailto:housingrenewals@monmouthshire.gov.uk); handed into Caldicot Hub (located in Caldicot Library, Woodstock Way, Caldicot, NP 26 5DB); or posted to Housing & Communities, Monmouthshire County Council, County Hall, The Rhadyr, Usk, NP15 1GA.

All responses must be received by **22<sup>nd</sup> December 2023**. For postal forms responses must be received by **Tuesday 2<sup>nd</sup> January 2024**.

-----

## PART 1: Tell us about you

The survey includes some questions about you. Some of the questions may not be important or relevant to you, but they are important to the person with that characteristic. Completing these questions will help us analyse results accurately as well as helping us make sure we reach a representative section of the Monmouthshire population. If you choose not to answer them, we will still include your views in our analysis.

Your details	
Name	
Post code	
Phone no.	
Email	

Please tell us which part of the community you are representing (please tick one)		
Resident		
Business/Agency		Name of Business/Agency
Community Council Member		
MCC Elected Member		
MP/MS		
Other		Please specify

What age group do you belong to? (please tick one)			
16-24		25-34	
35-44		45-54	
55-64		65+	
Prefer not to say			

Gender? (please tick one)	
Female	
Male	
Other gender identity	
Prefer not to say	
Is the gender you identify with the same as your sex registered at birth?	[Yes / No]

What is your ethnicity? (please tick one)			
<b>White</b>			
Welsh		English	
Northern Irish		Scottish	
British		Irish	
Gypsy, Roma or Irish Traveller		Any other White background	
<b>Asian or Asian British</b>			
Bangladeshi		Chinese	
Indian		Pakistani	
Any other Asian background			
<b>Black, African, Caribbean or Black British</b>			
African		Caribbean	
Any other Caribbean background			
<b>Mixed or Multiple ethnic groups</b>			

White and Asian		White and Black African	
White and Black Caribbean		Any other Mixed or Multiple ethnic background	
<b>Other ethnic group</b>			
Arab		Any other ethnic group	
<b>Prefer not to say</b>			

<b>Do you consider yourself to have a disability? (please tick one)</b>	
Yes	
No	
Prefer not to say	



## PART 2: Your comments

Please set out your comments in full, this will help us to understand your views and any issues you raise on suitability.

The Council has a legal and moral duty to meet the pitch needs of Gypsy & Travellers living in Monmouthshire. The Council is looking to identify land in sustainable locations where Gypsy & Traveller households can establish homes.

The Council's vision for meeting this duty and providing sites is:

- The Council recognises that safe, culturally appropriate accommodation is necessary for individuals to flourish in other parts of their lives.
- Small Gypsy and Traveller sites, ideally occupied by only one family or household.
- Each site will be a maximum of six pitches and be well designed and landscaped.
- To provide places for families who are already living and well-integrated in local life in Monmouthshire and have an identified need.
- Only a small amount of land has been proposed to be allocated from each of the three sites:
- *Do you have any comments on this vision?*

Please tell us what you think about the advantages/strengths of the site in Langley Close, Magor

**Please tell us what you think about the disadvantages/weaknesses of the site in Langley Close, Magor**

**Please tell us what you think about the advantages/strengths of the site in Bradbury Farm, Crick**

**Please tell us what you think about the disadvantages/weaknesses of the site in Bradbury Farm, Crick**

**Please tell us what you think about the advantages/strengths of the site in Oak Grove Farm, Crick**

**Please tell us what you think about the disadvantages/weaknesses of the site in Oak Grove Farm, Crick**

**Do you have any other comments on any of the sites**

**How useful was the information received during this consultation (please tick one)**

Very useful	<input type="checkbox"/>	Useful	<input type="checkbox"/>
Okay	<input type="checkbox"/>	Not very useful	<input type="checkbox"/>
Not useful at all	<input type="checkbox"/>		<input type="checkbox"/>

**Do you have any further comments?**



Please note that comments submitted will be available for public inspection and cannot be treated as confidential.

MCC comply with all legislation governing the protection of personal information, including the Data Protection Act 2018 and the UK: General Data Protection Regulations (GDPR). The personal information you supply in this form will remain strictly confidential and will only be shared with Grasshopper Communications for purposes of facilitating consultation on land for potential Gypsy & Traveller site provision. This information will be held and used in line with our retention policy. For more information about privacy, please visit: <https://www.monmouthshire.gov.uk/your-privacy/> or <https://grasshopper-comms.co.uk/privacy-policy/>.

**THANK YOU FOR YOUR RESPONSE TO THIS CONSULTATION**

## Appendix 3 Consultation launch media release

Gypsy and Traveller pitches in Monmouthshire

# Gypsy and Traveller pitches in Monmouthshire

Article last updated: 7th November 2023, Under category: [News](#)

Following a full council meeting on the 26th of October, Monmouthshire County Council will proceed with the Cabinet's decision to undertake a public consultation on the proposed council owned sites for possible use as Gypsy and Traveller pitches for local families in need of permanent place to live.

A six-week public consultation is expected to begin on the 9th of November, where residents, businesses, local stakeholders and the Gypsy and Travellers community can provide feedback on the proposed sites.

Along with comprehensive information on our website (to be published shortly:

<https://www.monmouthshire.gov.uk/gypsy-and-travellers/>), residents can attend public drop-in sessions at Church Hall, Portskewett, on the 22nd of November between 4.00pm – 7.00pm and at Magor and Undy Community Hub on the 23rd of November between 4.00pm – 7.00pm to find out more about the Council's obligations and considerations. Further drop-in sessions are also planned for the Gypsy and Traveller community. Additional information on the public drop-in sessions will be made available on our website.

Monmouthshire County Council has a legal and moral duty to provide sites within its Replacement Local Development Plan to meet identified needs. No decision has been made on which site(s) will be put forward. The public consultation will fully allow participants to gain information and provide feedback.

Monmouthshire County Council, Deputy Leader and Cabinet Member for Planning and Economic Development, Cllr Paul Griffiths said: "The public consultation will allow residents, businesses, local stakeholders and the Gypsy and Travelling community an opportunity to voice their opinion on the proposed sites. Please take this opportunity to engage with officers and councillors on what matters to you. I would urge everyone to read the information that will be available shortly to gain an understanding of the proposals."

Tags: [Monmouthshire](#), [news](#)

## Appendix 4 Drop in events poster advert

# Gypsy and Traveller sites consultation

Monmouthshire County Council would like to hear your views on the proposed Gypsy and Traveller sites in the Magor, Portskewett and Crick catchments.

Come to a drop-in event to learn more about what is proposed:

**Wednesday 22 November**  
**4pm-7pm**

Portskewett Church Hall,  
Crick Rd, Portskewett,  
Caldicot NP26 5UL

**Thursday 23 November**  
**4pm-7pm**

Magor and Undy Community  
Hub, Main Road, Undy,  
Caldicot NP26 3GD

Please send in your feedback  
by **Friday 22 December 2023**.



monmouthshire  
sir fynwy

Go to the  
consultation  
website:



# Appendix 5 Social media toolkit



## Monmouthshire County Council Gypsy, Roma and Traveller sites consultation Social media toolkit

Supporting images to be agreed with Monmouthshire County Council and Travelling Ahead.

### Post 1: Launch

Proposed date – 9 November

<b>Facebook</b>	Today, we are launching our public consultation on the proposals to develop Gypsy, Roma and Traveller sites in three locations near Magor and Crick.  Read more in our press release: [LINK TO NEWS STORY]
<b>Twitter/X</b>	Today, we are launching our public consultation on the proposals to develop Gypsy, Roma and Traveller sites in three locations near Magor and Crick.  Read more in our press release: [LINK TO NEWS STORY]  (205 characters)

### Post 2: Website update with exhibitions materials

Proposed date – 14 November

<b>Facebook</b>	We are seeking your views on our proposals to develop Gypsy, Roma and Traveller sites near Magor and Crick. All the information on how you can get involved is here: [LINK TO MAIN PROJECT PAGE]
<b>Twitter/X</b>	We are seeking your views on our proposals to develop Gypsy, Roma and Traveller sites near Magor and Crick. All the information on how you can get involved is here: [LINK TO MAIN PROJECT PAGE]  (190 characters)

### Post 3: Event 1

Proposed date – 17 November

<b>Facebook</b>	<p>Have your say on our proposals to develop Gypsy, Roma and Traveller sites. We have two drop-in events taking place in the next week, the first of which is at Portskewett Church Hall.</p> <p>We look forward to hearing your thoughts.</p> <p>Wednesday 22 November, 4pm-7pm.</p> <p>[LINK TO PROJECT PAGE]</p>
<b>Twitter/X</b>	<p>Have your say on our proposals to develop Gypsy, Roma and Traveller sites. We have two drop-in events taking place in the next week, the first being at Portskewett Church Hall.</p> <p>We look forward to hearing your thoughts.</p> <p>Wednesday 22 November, 4pm-7pm.</p> <p>[LINK TO PROJECT PAGE]</p> <p><i>(274 characters)</i></p>

### Post 4: Event 2

Proposed date – 20 November

<b>Facebook</b>	<p>We have organised a drop-in event at Magor and Undy Hub, so you can learn more about our proposals to develop Gypsy, Roma and Traveller sites in the local area.</p> <p>We look forward to hearing your thoughts.</p> <p>Thursday 23 November, 4pm-7pm</p> <p>[LINK TO PROJECT PAGE]</p>
<b>Twitter/X</b>	<p>We have organised a drop-in event at @MagorandUndyHub, so you can learn more about our proposals to develop Gypsy, Roma and Traveller sites in the local area.</p> <p>We look forward to hearing your thoughts.</p>



	<p>Thursday 23 November, 4pm-7pm</p> <p>[LINK TO PROJECT PAGE]</p> <p>(263 characters)</p>
--	--

### Post 5: Thanks for coming

Proposed date – 27 November

<b>Facebook</b>	<p>Thank you to those who attended our two drop-in events last week. Your views will go a long way in helping us in our final plans to develop sustainable Gypsy, Roma and Traveller sites that will suit all communities involved.</p> <p>If you weren't able to attend either event, you still have time to have your say: [LINK TO PROJECT PAGE]</p>
<b>Twitter/X</b>	<p>To those who attended our drop-in events last week, thank you. Your views will go a long way in helping us develop Gypsy, Roma and Traveller sites to suit all communities.</p> <p>If you couldn't attend either event, you still have time to submit your views: [LINK TO PROJECT PAGE]</p> <p>(275 characters)</p>

### Post 6: Deadline

Proposed dates – 6 December / 13 December / 20 December

<b>Facebook</b>	<p>The deadline to submit your views on the proposed Gypsy, Roma and Traveller sites in this consultation period is 22 December. If you haven't already, please submit your views here:</p> <p>[LINK TO FEEDBACK FORM]</p> <p>There will be further opportunities to have your say after this current process. Further consultation will be undertaken as part of the Replacement Local Development Plan 2018 – 2033 Deposit Plan consultation in 2024. There will also be further consultation as part of the planning application process.</p>
<b>Twitter/X</b>	<p>The deadline to submit your views on the proposed Gypsy, Roma and Traveller sites in this consultation period is 22</p>
	<p>December. If you haven't already, please submit your views here:</p> <p>[LINK TO FEEDBACK FORM]</p> <p>(205 characters)</p>

# Welcome

## Gypsy and Traveller sites consultation

### Welcome to this early consultation event.

Monmouthshire County Council has a legal and moral duty to ensure everyone has access to good quality accommodation. The Council recognises that safe, culturally appropriate accommodation is necessary for individuals to flourish in other parts of their lives.

In this drop-in event, you are able to learn more about the Gypsy and Traveller site consultation process, the proposed locations, and why it is important the Council acts.



Picture references: Photos of Greenfields Way site in Weston-Super-Mare. Taken from the 'Places We're Proud Of' report published by the National Policy Advisory Board on Gypsy and Traveller Housing, January 2021.

Feel free to ask any questions you have. You will also get the chance to meet Travelling Ahead, an organisation that supports Gypsy and Traveller communities.



### Contact:

 [HousingRenewals@monmouthshire.gov.uk](mailto:HousingRenewals@monmouthshire.gov.uk)

 01633 644644

 [www.monmouthshire.gov.uk/gypsy-and-traveller-sites-consultation/](http://www.monmouthshire.gov.uk/gypsy-and-traveller-sites-consultation/)



# Process

## Gypsy and Traveller sites consultation

The process of allocating Gypsy and Traveller sites is a lengthy process and takes several years before sites can be developed.

The Council's 2021 Gypsy and Traveller Accommodation Assessment (GTAA) has identified a need for an additional 13 pitches for the Gypsy and Traveller families already living in Monmouthshire.

- Three Council owned sites that have been identified as potentially suitable to meet the current needs for the Gypsy and Traveller community.
- The Council is holding a six-week public consultation on these sites. Cabinet will consider the feedback from this consultation and decide which site(s) will be allocated in the Replacement Local Development Plan 2018 - 2033.
- Monmouthshire County Council has worked closely with Travelling Ahead: Gypsy and Traveller Advice and Advocacy Service to co-design a consultation process to enable the Gypsy and Traveller communities to be well represented during this process.
- This consultation period is the first stage in an ongoing process. Further consultation will be undertaken as part of the Replacement Local Development Plan (RLDP) 2018 - 2033 and Deposit Plan in 2024. There will also be further consultation as part of any future planning applications.
- A strategic site located in Caldicot East has been proposed to be allocated for development within the RLDP Deposit Plan.



### Proposed next steps:

**9th November 2023**

Six-week public consultation begins, ending on 22nd December 2023



**Date to be confirmed after consultation**

Cabinet decision on which Gypsy and Traveller sites are to be included in the Deposit RLDP



**April/May 2024**

Deposit Plan to Council for endorsement to consult – the Deposit Plan is the full RLDP containing all site allocations and all policies



**September 2024**

Deposit Plan to Council following consultation for approval to submit to the Welsh Government for public examination in public by an independent inspector



**Date to be confirmed**  
Examination in public



**July 2025**

RLDP to Council for adoption

# Gypsy and Traveller sites consultation

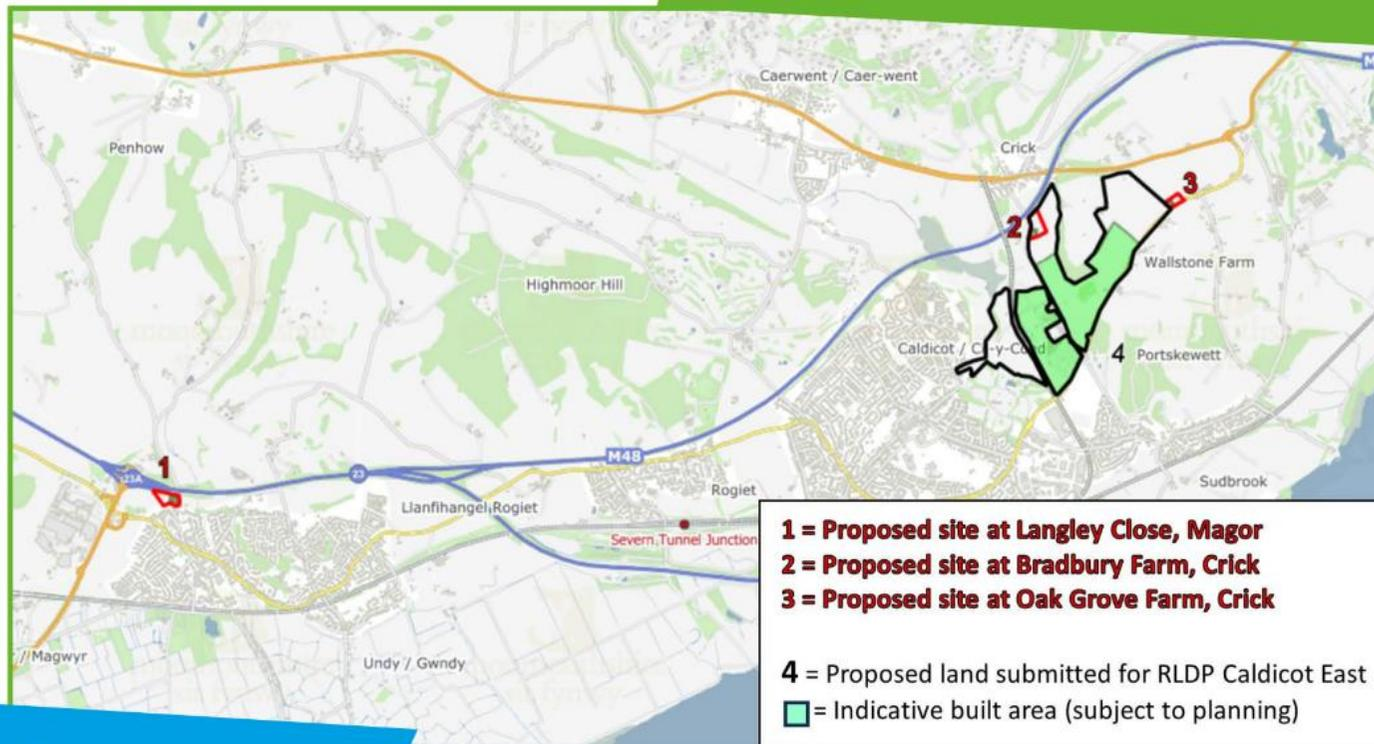

# Feedback

## Gypsy and Traveller sites consultation

### How to provide feedback and get in touch

We will ensure that everyone in the community has an equal and safe space to participate in the consultation process. We will have a zero-tolerance policy to any discriminatory or racist comments or behaviour. Any responses that include discriminatory or racist comments will not be considered.

The Council will listen to all members of the community, feedback will be summarised and reflected in the consultation report.



Please submit your comments electronically via **the MCC website, or the QR code**

### Alternatively, forms can be:



emailed to **housingrenewals@monmouthshire.gov.uk**



handed into **Caldicot Hub**

All responses must be received by **22nd December 2023.**



### Contact:



HousingRenewals@monmouthshire.gov.uk



01633 644644



www.monmouthshire.gov.uk/gypsy-and-traveller-sites-consultation/



# Profile: Langley Close

### Site Size:

Approx 23,431m<sup>2</sup>

### Pitch Capacity:

Sufficient to meet MCC's pitch needs\*

\*It is recommended no more than 5 or 6 pitches



## Gypsy and Traveller sites consultation



### General Description:

- Urban
- Access off St Brides Road
- The land forms part of the Council's County Farms estate and is occupied via a grazing license. It is anticipated this license would need to be terminated/amended should the site be supported for this use
- Residential properties adjoining southern boundary. M4 to the north, open land to east and west
- Tree belt around the site



### For more information:

[www.monmouthshire.gov.uk/gypsy-and-traveller-sites-consultation/](http://www.monmouthshire.gov.uk/gypsy-and-traveller-sites-consultation/)



# Profile: Oakgrove Farm

## Gypsy and Traveller sites consultation

**Site Size:**  
Approx 7,976 m<sup>2</sup>

**Pitch Capacity:**  
Sufficient to meet MCC's pitch needs\*  
\*It is recommended no more than 5 or 6 pitches



### General Description:

- Rural
- Situated on B4245 approximately a mile from the edge of Caldicot
- The land forms part of the Council's County Farms estate and is occupied via an agricultural tenancy. It is anticipated this tenancy would need to be amended should the site be supported for this use
- Land currently used for agriculture



### For more information:

[www.monmouthshire.gov.uk/gypsy-and-traveller-sites-consultation/](http://www.monmouthshire.gov.uk/gypsy-and-traveller-sites-consultation/)



# Profile: Bradbury Farm

## Gypsy and Traveller sites consultation

**Site Size:**  
Approx 18,022 m<sup>2</sup>

**Pitch Capacity:**  
Sufficient to meet MCC's pitch needs\*  
\*It is recommended no more than 5 or 6 pitches



### General Description:

- Rural
- Situated directly off Crick Road
- The land forms part of the Council's County Farms estate and is occupied via an agricultural tenancy. It is anticipated this tenancy would need to be amended should the site be supported for this use
- M48 to the north elevation of the land
- Hedgerow and fencing to east, west and south elevation

Page 176



**For more information:**  
[www.monmouthshire.gov.uk/gypsy-and-traveller-sites-consultation/](http://www.monmouthshire.gov.uk/gypsy-and-traveller-sites-consultation/)



# Vision

## Gypsy and Traveller sites consultation

The Council has a legal and moral duty to meet the pitch needs of Gypsy & Travellers living in Monmouthshire. The Council is looking to identify land in sustainable locations where Gypsy & Traveller households can establish homes.



### The Council's vision for meeting its duty and providing sites is:

The Council recognises that safe, culturally appropriate accommodation is necessary for individuals to flourish in other parts of their lives.

Small Gypsy and Traveller sites, ideally occupied by only one family or household.

Each site will be a maximum of six pitches and be well designed and landscaped.

To provide places for families who are already living and well-integrated in local life in Monmouthshire and have an identified need.

Only a small amount of land has been proposed to be allocated from each of the three sites.



### For more information:

[www.monmouthshire.gov.uk/gypsy-and-traveller-sites-consultation/](http://www.monmouthshire.gov.uk/gypsy-and-traveller-sites-consultation/)



# Key documents for download

# Gypsy and Traveller sites consultation

 **RAG, updated on 26th July 2023**  
 Monmouthshire County Council uses RAG (Red, Amber, Green) reports to measure the progress of a given project which would influence their next phases.

 **Frequently Asked Questions**

 **The Gypsy and Traveller Assessment 2021**



 **Consultation Website**

 **Welsh Government - Guidance and Planning**



**Picture references:** Photos of Greenfields Way site in Weston-Super-Mare and Brooks Green, Harford. Taken from the 'Places We're Proud Of' report published by the National Policy Advisory Board on Gypsy and Traveller Housing, January 2021.

 **monmouthshire**  
 sir fynwy

**For more information:**  
[www.monmouthshire.gov.uk/gypsy-and-traveller-sites-consultation/](http://www.monmouthshire.gov.uk/gypsy-and-traveller-sites-consultation/) 

# Appendix 7 Photos to support the consultation

## Appendix 7a

### Mill 1 St Brides



Appendix 7b

St Brides Road



MONMOUTHSHIRE COUNTY COUNCIL'S LAND EVALUATION -Appendix 1

Gypsy & Traveller Site Identification – MCC Land Evaluation	
<p><b>MCC Land – Langley Close, Magoz</b></p> <p><b>Site Size – Approx 23.43ha<sup>2</sup></b>      <b>Pitch Capacity – sufficient to meet MCC's pitch needs<sup>1</sup></b></p> <p><sup>1</sup>The site has the capacity for additional pitches above the identified need, but these are not required. Large sites and provision above 5 or 6 units are not recommended.</p> <p><b>General Description</b></p> <ul style="list-style-type: none"> <li>• Upton</li> <li>• Access off St Brides Road</li> <li>• The land forms part of the Council's County Farms estate and is occupied via a grazing licence. It is anticipated this licence would need to be terminated/terminated should the site be supported for this use</li> <li>• (Woodland) prospective adjacent woodland boundary. ME to the north, open land to west and south</li> <li>• Tree belt around the site</li> </ul> <p><b>Ward – Magoz West</b></p> <p><b>Photo's</b></p>     	
<p><b>Strengths</b></p> <ul style="list-style-type: none"> <li>• Level land</li> <li>• Scope for expansion (within the context of not creating a large site)</li> <li>• Ability to create a margin between houses and M4</li> <li>• New access can be created on St Brides Close</li> </ul> <p><b>Opportunities</b></p>	<p><b>Weaknesses</b></p> <ul style="list-style-type: none"> <li>• Greenfield</li> <li>• Mineral safeguarding area</li> <li>• Existing access is not suitable</li> <li>• Traffic and noise assessments/surveys would be needed given the proximity of the M4 - a TAN 11 Noise assessment to establish whether the site is suitable having regard to the existing background noise levels.</li> <li>• Woodland along M4 corridor may support Dormouse, reptiles, birds and Scaods</li> <li>• Adjacent to existing homes</li> <li>• There would be a loss to the current grazing licence holder who would need to be served notice to terminate/terminated their existing licence.</li> </ul> <p><b>Threats (Risk)</b></p> <ul style="list-style-type: none"> <li>• Close to M4 – air and noise pollution.</li> </ul>
<ul style="list-style-type: none"> <li>• Due to the size of the land, there is scope to develop just a part of the site away from existing homes and M4</li> </ul> <p><b>Key Internal Feedback Comments</b></p> <ul style="list-style-type: none"> <li>• Greenfield</li> <li>• Mineral Safeguarding area</li> <li>• Land should be investigated for possible land contamination, and if necessary remediated prior to introducing a receptor.</li> </ul> <p><b>Gypsy &amp; Traveller Community Comments</b></p> <ul style="list-style-type: none"> <li>• Good transport links are needed for work purposes. Supermarket deliveries and taxis will be needed. Near shops is helpful but not so near that kids can walk off into town on their own and get into trouble. Easier to get Planning the further you are away from other people due to hostility. Putting sites near to settled community doesn't work.</li> <li>• Not suitable as wish to remain in home community for school, employment and social reasons<sup>2</sup></li> </ul> <p><sup>2</sup> This relates to one household and doesn't mean that it's not suitable for other families.</p> <p><b>Traveling Ahead Comments</b></p> <ul style="list-style-type: none"> <li>• Although close to existing homes, considered a possible option due to the ability to develop the site from the west to centre and create a margin to the existing homes. Being a sizeable site creates flexibility. Near M4 so issue of pollution and noise.</li> </ul> <p><b>Recommendation</b></p>	<ul style="list-style-type: none"> <li>• Possible risk of land contamination eg unrecorded waste disposal from nearby housing development or disposal of made ground or parking from heavy vehicles/equipment.</li> </ul> <p>Retain in process for consideration by Members Workshop</p>

LANGLEY CLOSE – CONTEXT – IMAGERY SOURCE GOOGLE EARTH -- Appendix 2

Langley Close Site – Part of Gwent Levels. Location within Magor – North West corner only 10m from M4 / J23A. Grade 2 listed building (Woodland House) only 40m from site. Existing properties only 48m from tree buffer. SINC only 70m. Field is split into 3 separate smaller fields by hedgerows. No reasonable buffer can be created to any of these.

'Gateway to Wales' - View from M4 bridge over St Brides Road. Site is immediately behind trees which provides little screening in winter.



M4 Westbound at J23A Magor showing raised slip road and idling traffic. A typical day of noise and air pollution.



'Gateway to Wales' - View towards site from slip road



ST BRIDES ROAD – THE SITE LOCATION (LANE RUNS BETWEEN B4245 AND A48) - IMAGERY SOURCE GOOGLE EARTH - Appendix 3

Langley Close site. Existing Access On Bend. Note approach to 60mph zone. Single track road



New access has to go on this stretch – note narrowness of road and bridge under M4. Also no footpath – danger for pedestrians especially children and mobility impaired.



Low narrow bridge under M4 and blind bend. M4 is raised, slip road is raised further...



New access must be on straight part of road. Max 28m visibility in either direction due to 2 blind bends. Trees also block view. Cannot comply with Visibility Splay and Sight Stopping Distance requirements. Doesn't meet highway safety regs Manual for Streets 2 and TAN18

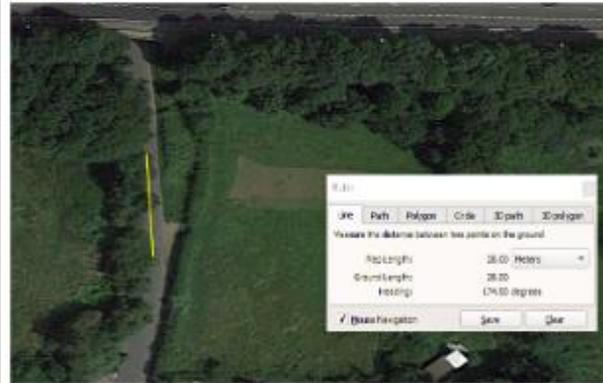

[AIR POLLUTION DATA – SOURCE NAEI WEB SITE-Appendix 4](#)



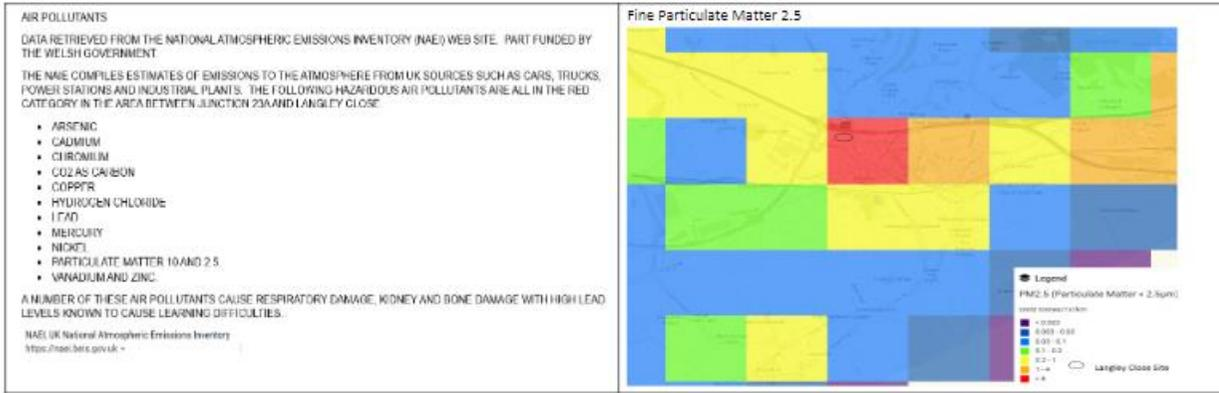

## NOISE POLLUTION

DATA RETRIEVED FROM THE EXTRIUM WEB SITE.

BASED ON DATA MOST RECENTLY PUBLISHED BY WELSH GOVERNMENT IN 2017, I.E. BEFORE REMOVAL OF TOLLS AND INCREASED TRAFFIC (REPORTED 16% INCREASE IN FIRST YEAR).

THE VIEWERS SHOW NOISE LEVELS FOR ROADS AND RAILWAYS AND INDUSTRIAL NOISE LEVELS.

MOST OF THE LANGLEY CLOSE SITE IS OVER 70DB AND ONE THIRD OF THE SITE EXCEEDS 75DB WHICH IS THE HIGHEST (SHOWN IN DARK BLUE)

SECTION 7.7.3.2 OF BS 8233:2014 ENTITLED 'DESIGN CRITERIA FOR EXTERNAL NOISE' STATES; "FOR TRADITIONAL EXTERNAL AREAS THAT ARE USED FOR AMENITY SPACE, SUCH AS GARDENS AND PATIOS, IT IS DESIRABLE THAT THE EXTERNAL NOISE LEVEL DOES NOT EXCEED 50 DB L<sub>AEQ,T</sub> WITH AN UPPER GUIDELINE VALUE OF 55 DB.

Wales Noise and Air quality Viewer:  
<http://extrium.co.uk/walesnoiseviewer.html>

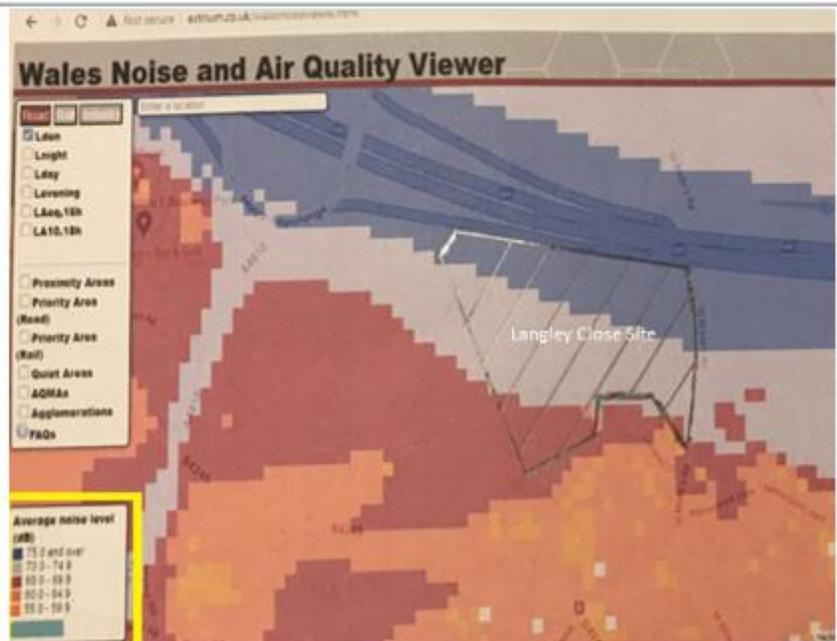

IMAGERY SOURCE -Newport Local Development Plan – Candidate Site register (october 2023) - Appendix 5- 3 pages maps

Page 187

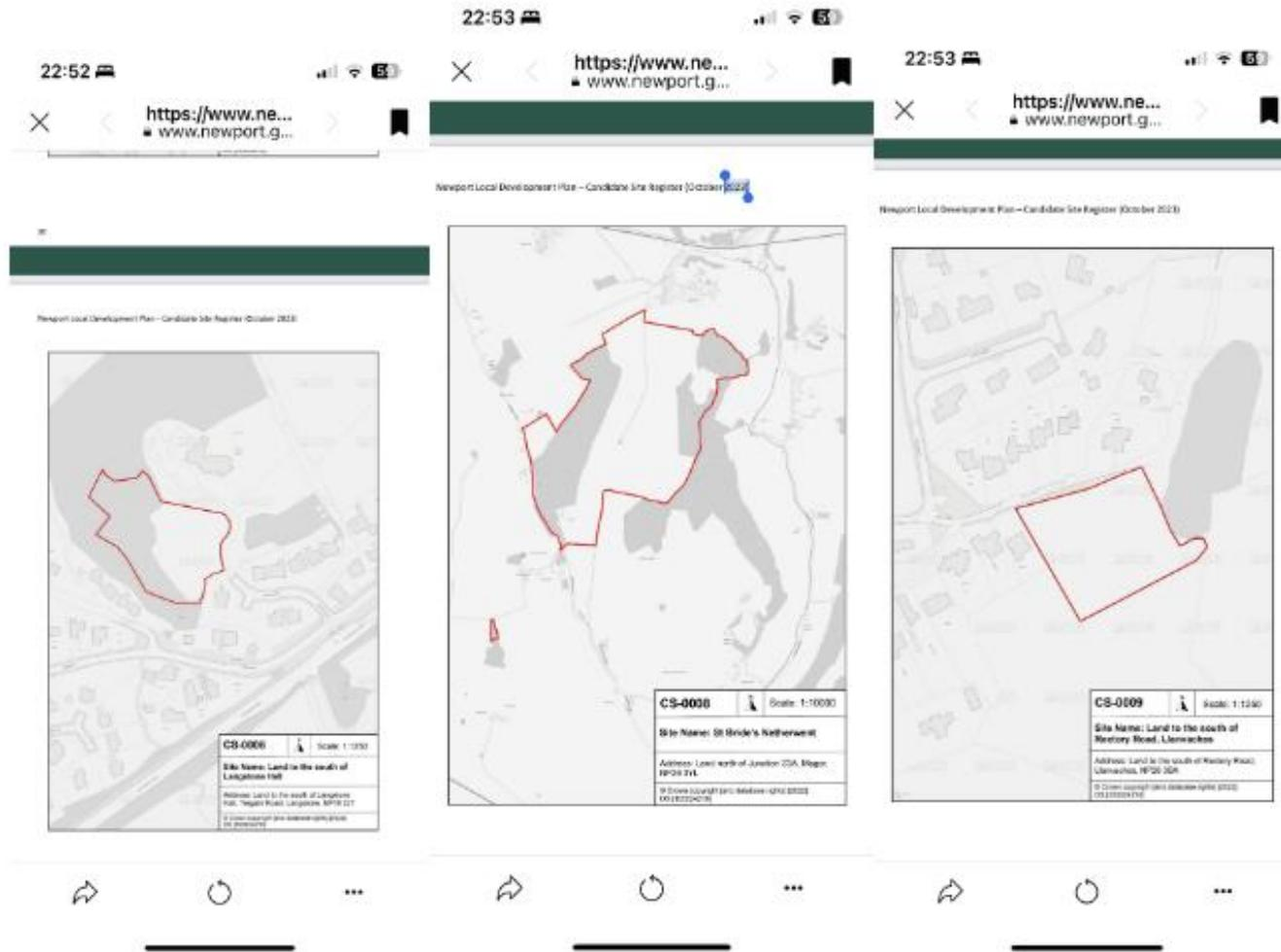

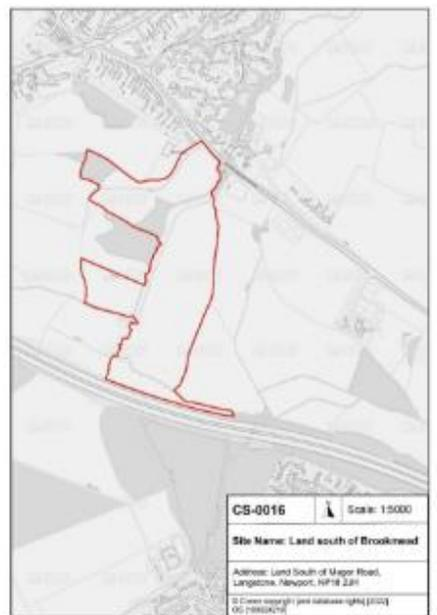
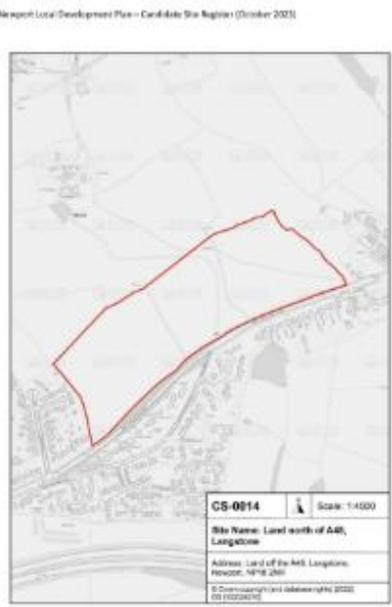

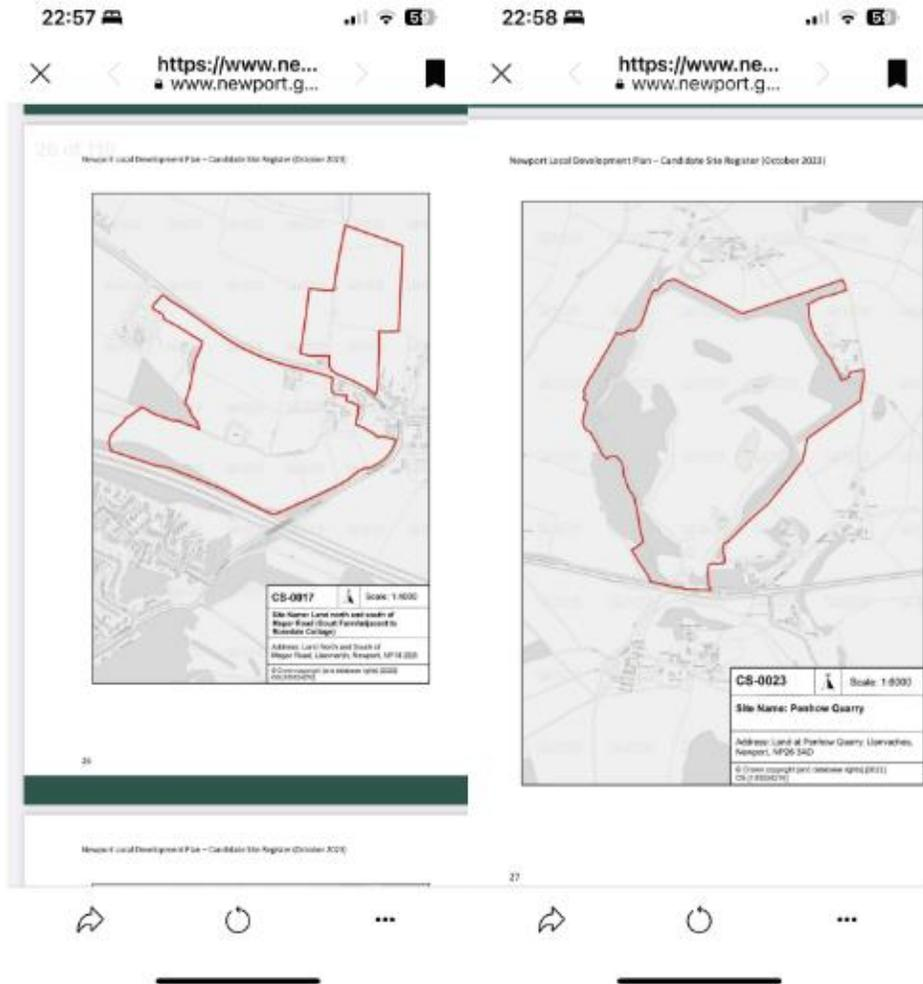

Appendix 7d

river



## Appendix 7e

Fig 1. Lorry on left of picture having had to reverse into Langley Close, having caused traffic disruption in St. Brides Road. Note Volvo car unable to pass proposed site entrance as it is single track at that point.



Fig 2. Another lorry having to turn around in St Brides Road/Langley Close



Fig 3. Lorries trying to pass each other in St Brides road. Note dangerous driving over pavement.



Fig 4A. Lorry trying to turn around in Langley Close. Note dangerous move over St Brides Road pavement





Fig 4B - Yet another lorry stuck in St Brides Road. So large it was unable to reverse safely into Langley Close so it chose to reverse into Netherwent view. BUT it still had to dangerously mount the pavement to achieve this.



Fig 5. Blind Bend on St Brides Road – Even Police cars have to drive in the middle of the road seeking visibility.



Fig 6 . Mon CC Refuse truck in middle of road near proposed site entrance – Note how it takes up much of the single track road



Fig 7 Example blind bend in St Brides Road



Fig 8. Tractor approaching blind bend near to proposed site entrance - Note how it takes up most of single track road



Fig 9 . Regular tailbacks on B4245



Fig 10 . Tailbacks on B4245



Fig 11. Water Run Off from proposed site



Fig 12 .Other flooding in St Brides Road and blind bend



Fig 13 Flooding at junction of B4245 and St Brides Road



Fig 14. Sparrowhawk in garden with kill



Fig 15. Egrets – a new visitor to the proposed site

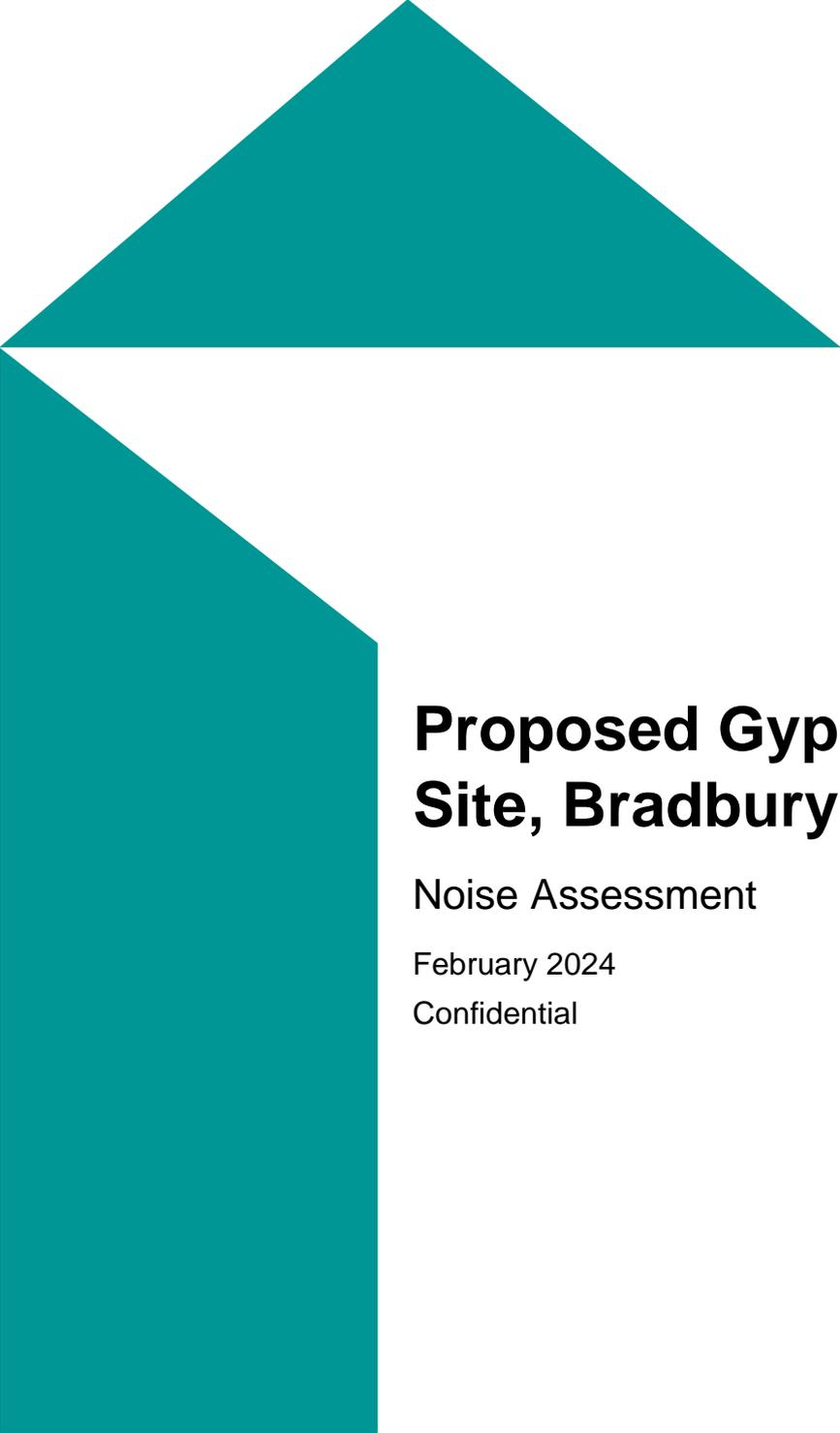

Fig 16. Recent badger sett in middle of proposed site – Note also gradient on site i.e it is not level



This page is intentionally left blank





# **Proposed Gypsy and Traveller Site, Bradbury Farm, Crick**

Noise Assessment

February 2024

Confidential

This page left intentionally blank for pagination.

Mott MacDonald  
10 Temple Back  
Bristol BS1 6FL  
United Kingdom

T +44 (0)117 906 9500  
mottmac.com

# **Proposed Gypsy and Traveller Site, Bradbury Farm, Crick**

Noise Assessment

February 2024

Confidential

# Issue and Revision Record

Revision	Date	Originator	Checker	Approver	Description
0	09/02/24	R Roper	A Monk-Steel	R Perkins	First draft for client comment
1	18/04/24	R Roper	A Monk-Steel	R Perkins	Client comment addressed

**Document reference:** 100115516 | NS002 | P01 | 100115516

**Information class:** Standard

This document is issued for the party which commissioned it and for specific purposes connected with the above-captioned project only. It should not be relied upon by any other party or used for any other purpose.

We accept no responsibility for the consequences of this document being relied upon by any other party, or being used for any other purpose, or containing any error or omission which is due to an error or omission in data supplied to us by other parties.

This document contains confidential information and proprietary intellectual property. It should not be shown to other parties without consent from us and from the party which commissioned it.

# Contents

<b>1</b>	<b>Introduction</b>	<b>1</b>
1.1	Project description	1
1.2	Site description	1
1.3	Scope of the assessment	2
<b>2</b>	<b>Guidance and legislation</b>	<b>4</b>
2.1	Planning Policy Wales	4
2.2	Local authority policy and guidance	5
2.3	TAN 11	6
2.4	ProPG	8
2.5	British Standard BS 4142:2014+A1:2019	10
2.6	British Standard BS 8233:2014	10
2.7	World Health Organization guidance	11
2.8	British Standard BS 7445:2003	11
<b>3</b>	<b>Survey methodology</b>	<b>12</b>
3.1	Measurement procedure	12
3.2	Measurement locations	13
3.3	Equipment	14
3.4	Weather conditions	14
3.5	Limitations	14
<b>4</b>	<b>Measurement results</b>	<b>16</b>
4.1	Long term	16
4.2	Short term	17
<b>5</b>	<b>Assessment</b>	<b>19</b>
5.1	TAN 11	19
5.2	ProPG	19
5.3	BS 4142	20
<b>6</b>	<b>Conclusions</b>	<b>21</b>
<b>A.</b>	<b>Acoustic Glossary</b>	<b>22</b>
<b>B</b>	<b>Comparison between 5 minute sample measurements at ST and LT locations.</b>	<b>23</b>

## Tables

Table 3.1: Noise measurement location details	13
Table 3.2: Inventory of noise measurement equipment	14
Table 3.3: Weather summary	14
Table 4.1: LT1 measurement results (free-field measurement)	17
Table 4.2: Summary of ST measurements (15 minutes for each measurement)	18

## Figures

Figure 1.1: Proposed site layout	2
Figure 4.1: LT1 plot of results of the long term measurement	17

# 1 Introduction

## 1.1 Project description

Monmouthshire County Council (MCC) has a legal and moral duty to ensure everyone has access to good quality homes. MCC recognises that safe, culturally-appropriate accommodation is necessary for individuals to flourish in other parts of their lives. In accordance with the Housing (Wales) Act, 2014, MCC has identified a need for additional sites to house the Gypsy and Traveller families already living in Monmouthshire.

Three Council owned sites in Monmouthshire have been identified as potentially suitable to meet the current needs for the Gypsy and Traveller community. Mott MacDonald was commissioned by MCC to conduct noise surveys and assessments at proposed development sites in Monmouthshire at:

- Langley Close, Magor,
- Land at Bradbury Farm, Crick; and
- Land at Oak Grove Farm, Portskewett.

It is proposed to develop one of these sites as a Gypsy and Travellers site.

Mott MacDonald has been appointed by MCC to provide a noise assessment report as part of MCC's Gypsy and Traveller Accommodation Assessment (GTAA) identification study for the Bradbury Farm, Crick, Monmouthshire (hereafter referred to as "**the proposed Gypsy and Traveller site**" or simply "the site"), one of the three council-owned identified sites for potential development. The proposed Gypsy and Travellers site is understood to comprise the construction of up to six pitches that will include parking and a collective utility block with access gained via Crick Road which runs along the western boundary of the site.

This report describes the noise impact assessment for the proposed development at Bradbury Farm, Crick, and assesses the potential impact on the development due to existing noise levels and sets criteria for any noise emissions from the site.

## 1.2 Site description

The site is currently three grazed agricultural fields south of the M48 motorway and east of Crick Road. To the east the agricultural land rises towards Ballan Wood whilst to the south is further agricultural land. The site is relatively flat.

The noise environment at the northern end of the site is dominated by traffic noise from the M48 motorway which is elevated in relation to the site. To the southern end of the site the noise from the M48 motorway is still dominant but intermittent road traffic noise from Crick Road is also present.

The site layout has been modified and is shown in Figure 1.1.

Click or tap here to enter text. **Figure 1.1: Proposed site layout**

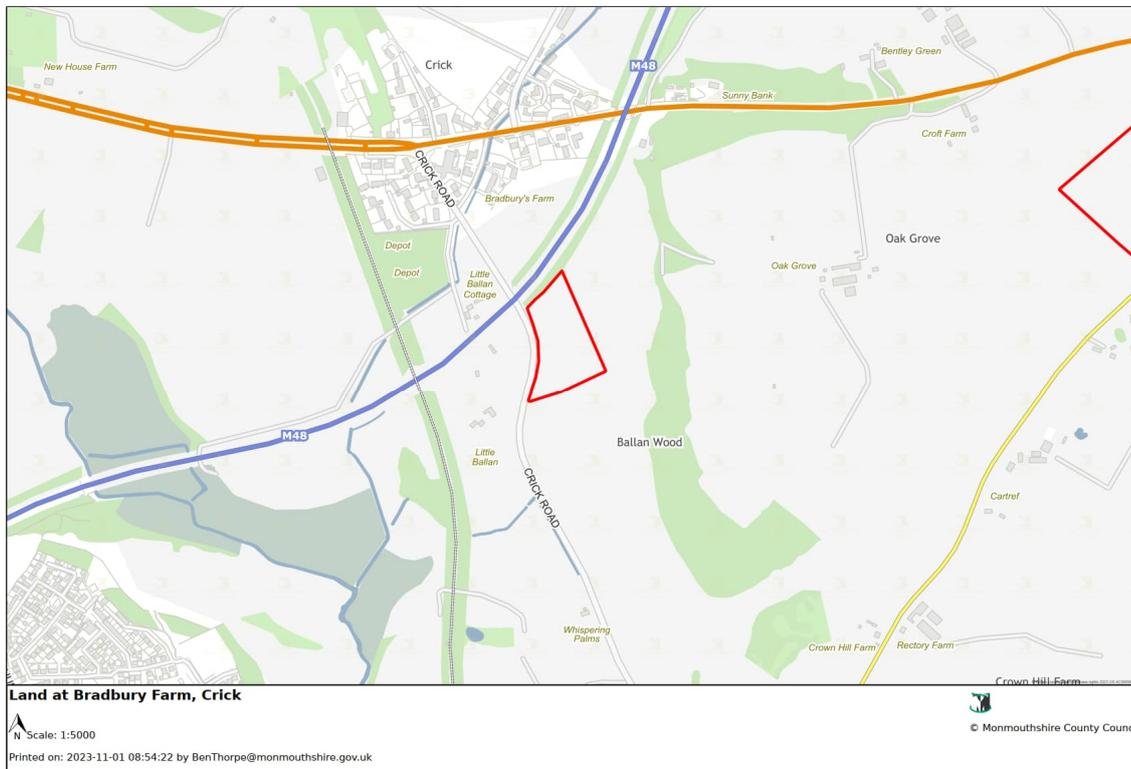

Source: Monmouthshire County Council

### 1.3 Scope of the assessment

The purpose of the survey was to quantify the ambient noise levels impacting the site and the background sound levels at the nearby noise sensitive receptors (NSRs).

The suitability of the proposed sites is considered using Technical Advice Note, TAN 11: Noise (1997), Professional Practice Guidance on Planning and Noise (ProPG) with due consideration to the Technical Advice Note 11: Air Quality, Noise and Soundscape' (2022) and 'Supporting Document 1: Soundscape Design' (2022).

Noise levels due to existing noise sources potentially impacting the proposal are assessed in terms of the implications for the internal noise levels within a typical mobile home. As the type and construction of these mobile homes will vary this will be indicative only. Any mitigation measure proposed will be aimed at the layout and landscaping of the site as the design of mobile homes is clearly beyond the control of the designers.

Environmental noise limits for any proposed new plant associated with the development, would be set in accordance with the guidance in British Standard (BS) 4142:2014+A1:2019 *Methods for rating and assessing industrial and commercial sound*, in the context of the *TAN 11, Planning Policy Wales* and any specific local authority requirements.

This report details the monitoring methodology, noise assessment methodology and any assumptions and limitations associated with the monitoring, and documents the results of the baseline monitoring. It appraises the potential impact of existing noise levels, using TAN 11 and the ProPG assessment methodology, on the proposed development and sets criteria for potential noise emissions from the site.



The baseline monitoring data has been processed in accordance with the requirements of BS 4142 in order to set criteria for noise emissions from any mechanical plant such as toilet extracts, generators, air-conditioning units etc associated with the proposed development.

The baseline monitoring data has also been processed in accordance with BS 7445 (2003) '*Description and measurement of environmental noise*', British Standard BS 8233 (2014) '*Guidance on sound insulation and noise reduction for buildings*'.

## 2 Guidance and legislation

### 2.1 Planning Policy Wales

Planning Policy Wales (PPW) points out some similarities between air quality and noise in the way they impact a proposed site. Noise is not just considered in terms of its level. PPW also discusses the 'soundscape'. Selected sections of Planning Policy Wales, Edition 11 | February 2021 are reproduced below:

#### **Air Quality and Soundscape**

*6.7.1 Clean air and an appropriate soundscape, contribute to a positive experience of place as well as being necessary for public health, amenity and well-being. They are indicators of local environmental quality and integral qualities of place which should be protected through preventative or proactive action through the planning system. Conversely, air, noise and light pollution can have negative effects on people, biodiversity and the resilience of ecosystems and should be reduced as far as possible.*

*6.7.3 Certain sounds, such as those created by trees, birds or water features, can contribute to a sense of tranquillity whilst others can be reassuring as a consequence of their association with the normality of everyday activities. Problematic forms of sound are generally experienced as noise pollution and can affect amenity and be prejudicial to health or a nuisance.*

*6.7.4 The planning system should maximise its contribution to achieving the well-being goals, and in particular a healthier Wales, by aiming to reduce average population exposure to air and noise pollution alongside action to tackle high pollution hotspots. In doing so, it should consider the long-term effects of current and predicted levels of air and noise pollution on individuals, society and the environment and identify and pursue any opportunities to reduce, or at least, minimise population exposure to air and noise pollution, and improve soundscapes, where it is practical and feasible to do so.*

*6.7.5 In taking forward these broad objectives the key planning policy principle is to consider the effects which proposed developments may have on air or soundscape quality and the effects which existing air or soundscape quality may have on proposed developments. Air Quality and soundscape influence choice of location and distribution of development and it will be important to consider the relationship of proposed development to existing development and its surrounding area and its potential to exacerbate or create poor air quality or inappropriate soundscapes. The agent of change principle says that a business or person responsible for introducing a change is responsible for managing that change. In practice, for example, this means a developer would have to ensure that solutions to address air quality or noise from nearby pre-existing infrastructure, businesses or venues can be found and implemented as part of ensuring development is acceptable.*

*6.7.6 In proposing new development, planning authorities and developers must, therefore:*

- *address any implication arising as a result of its association with, or location within, air quality management areas, noise action planning priority areas or areas where there are sensitive receptors*
- *not create areas of poor air quality or inappropriate soundscape; and*
- *seek to incorporate measures which reduce overall exposure to air and noise pollution and create appropriate soundscapes.*

To assist decision making it will be important that the most appropriate level of information is provided and it may be necessary for a technical air quality and noise assessment to be undertaken by a suitably qualified and competent person on behalf of the developer.

6.7.8 Good design, for example setting back buildings from roads to avoid canyon effects and using best practice in terms of acoustic design to ensure the appropriate and intended acoustic environment of completed developments should be incorporated at an early consideration in the design and planning process.

## 2.2 Local authority policy and guidance

Bradbury Farm falls under the ‘Monmouthshire County Council Adopted Local Development Plan 2011-2021’ which was adopted 27 February 2014 and sets out the plans, visions and policies for development.

6.3.60 Policy EP1 seeks to prevent development proposals that would result in unacceptable risk or harm due to air, light, noise or water pollution, contamination or land instability.

### EP1 - Amenity and Environmental Protection

Development, including proposals for new buildings, extensions to existing buildings and advertisements, should have regard to the privacy, amenity and health of occupiers of neighbouring properties. Development proposals that would cause or result in an unacceptable risk /harm to local amenity, health, the character /quality of the countryside or interests of nature conservation, landscape or built heritage importance due to the following will not be permitted, unless it can be demonstrated that measures can be taken to overcome any significant risk:

- .....
- Noise pollution;

.....

The Replacement Local Development Plan (RLDP) – 2018-2033 includes the ‘Replacement Local Development Plan Sustainability Appraisal Scoping Report Appendix 1 – Review of Plans, Policies, Programmes and Strategies November 2022, in which Monmouthshire Council includes the following section of table:

**Table 2.1 Selected Section of Table Sustainability Appraisal Scoping Report Appendix 1 – Review of Plans, Policies, Programmes and Strategies**

ISA Theme: Health & Well-being	
International, European, National (UK), National Wales	
Planning Policy Wales Edition 11 (2021) Technical Advice Note (TAN) 11: Noise (1997) (Revised TAN currently being consulted on by WG) Technical Advice Note (TAN) 16: Sport, recreation and open space (2009)	<i>Planning Policy Wales (PPW) sets out the land use planning policies of the Welsh Government. It is supplemented by a series of Technical Advice Notes. It translates our commitment to sustainable development into the planning system so that it can play an appropriate role in moving towards sustainability. Planning Policy Wales (PPW) puts a commitment to achieving the Well-being goals of the Well-being of Future Generations Act at the centre of the planning system in Wales. PPW notes that planning</i>

---

*authorities have a role to play in the prevention of physical and mental illnesses caused by pollution, isolation from society and activities, and must consider the impact of new development on communities and prioritise health protection. It requires planning authorities to:*

- Contribute to the protection and, where possible, the improvement of people’s health and wellbeing as a core component of achieving the well-being goals and responding to climate change.*
  - Consider the possible impacts of developments – positive and/or negative – on people’s health at an early stage will help to clarify the relevance of health and the extent to which it needs to be considered.*
  - Ensure, as far as is practicable, that noise-sensitive developments, such as hospitals, schools, and housing, that need to be located close to the existing transportation infrastructure to facilitate access, are designed in such a way as to limit noise levels within and around those developments.*
  - Consider national air quality objectives, recognising that they represent a pragmatic threshold above which government considers the health risks associated with air pollution are unacceptable.*
- 

### 2.3 TAN 11

Planning Policy Wales is supplemented by a series Technical Advice Notes (TAN) that provide detailed planning advice on different subjects. TAN 11: Noise (1997) provides a methodology for assessing the suitability of a site for residential development near existing sources of noise. It provides threshold noise levels for Noise Exposure Categories (NECs), which determine the suitability of the site for residential development and within which various levels of consideration to mitigation should be given. These noise exposure categories are provided for road, rail, aircraft and mixed sources. Separate noise level ranges are specified for the day-time and night-time periods for each of the NECs. The degree of consideration required for each Noise Exposure Category is described in Table 2.2 below.

**Noise Table 2.2: Noise exposure categories for dwellings**

<b>Noise Exposure Categories</b>	
A	Noise need not be considered as a determining factor in granting planning permission, although the noise level at the high end of the category should not be regarded as desirable.
B	Noise should be taken into account when determining planning applications and, where appropriate, conditions imposed to ensure an adequate level of protection.

---

### Noise Exposure Categories

C	Planning permission should not normally be granted. Where it is considered that permission should be given, for example, because there are no alternative quieter sites available, conditions should be imposed to ensure a commensurate level of protection against noise.
D	Planning permission should normally be refused.

Source: TAN11, Annex A, Table 1

The noise level ranges of the various categories are shown in Table 2.3 below.

**Table 2.3: Recommended Noise Exposure Categories (NEC) for new dwellings near existing noise sources**

Noise levels<sup>(1)</sup> corresponding to noise exposure categories in  $L_{Aeq, T}$  dB

Noise source	Time period	Noise exposure category			
		A	B	C	D
Road traffic	Day time 07:00 to 23:00	< 55	55-63	63-71	> 72
	Night time 23:00 to 07:00 <sup>(2)</sup>	< 45	45-57	57-66	> 66
Rail traffic	Day time 07:00 to 23:00	< 55	55-66	66-74	> 74
	Night time 23:00 to 07:00 <sup>(2)</sup>	< 45	45-59	59-66	> 66
Air traffic <sup>(3)</sup>	Day time 07:00 to 23:00	< 57	57-66	66-72	> 72
	Night time 23:00 to 07:00 <sup>(2)</sup>	< 48	48-57	57-66	> 66
Mixed sources <sup>(4)</sup>	Day time 07:00 to 23:00	< 55	55-63	63-72	> 72
	Night time 23:00 to 07:00 <sup>(2)</sup>	< 45	45-57	57-66	> 66

**Notes**

<sup>(1)</sup> Noise levels: the noise level(s) ( $L_{Aeq, T}$ ) used when decided the NEC of a site should be representative of typical conditions.

<sup>(2)</sup> Night-time noise levels (2300-0700): sites where individual noise events regularly exceed 82 dB  $L_{Amax}$  (S time weighting) several times in any hour should be treated as being in NEC C, regardless of the  $L_{Aeq, 8 \text{ hour}}$  (except where the  $L_{Aeq, 8 \text{ hour}}$  already puts the site in NEC D).

<sup>(3)</sup> Air craft noise: daytime values accord with the contour values adopted by the Department of Transport which relate to levels measured 1.2m above open ground. For the same amount of noise energy, contour values can be up to 2 dB(A) higher than those of other sources because of ground reflection effects.

<sup>(4)</sup> Mixed sources: this refers to any combination of road, rail, air and industrial noise sources. The "mixed source" values are based on the lowest numerical values of the single source limits in the table. The "mixed source" NECs should only be used where no individual noise source is dominant.

To check is any individual noise source is dominant (for the purposes of this assessment) the noise level from the individual sources should be determined and then combined by decibel additional (remembering first to subtract 2 dB(A) from any aircraft noise contour values). If the level of any one source then lies within 2 dB(A) of the calculated combined value, that source should be taken as the dominant one and the site assessed against the appropriate NEC for that source, rather than using the "mixed source" NECs. If the dominant source is industrial noise see paragraph B17 of Annex B (of TAN 11).

If the contribution of the individual noise sources to the overall noise level cannot be determine by measurement and/or calculation, then the overall measured level should be used and the site assessed against the NECs for "mixed sources".

Source: TAN 11, Annex A, Table 2

In relation to noise from industrial or fixed mechanical sources TAN 11 recommends the use of BS 4142 as described in Section 2.5 below.

## 2.4 ProPG

ProPG states: ‘ although the policy coverage is limited to England, the approach may be useful in other parts of the UK.’ It has been applied here along side Welsh guidance to provide the fullest picture of the suitability of the site for residential occupation.

Professional Practice Guidance on Planning and Noise (ProPG)<sup>4</sup> provides guidance which reflects the policy set out in National Planning Policy Framework (NPPF), Noise Planning Statement for England (NPSE) and Planning Practice Guidance - Noise (PPGN) specifically to be used for new residential developments.

ProPG encourages sustainable and better acoustic design for new residential developments and aims to protect people from the harmful effects of noise. The aims of ProPG are to:

- “advocate full consideration of the acoustic environment from the earliest possible stage of the development control process;
- encourage the process of good acoustic design in and around new residential developments;
- outline what should be taken into account in deciding planning applications for new noise-sensitive developments;
- improve understanding of how to determine the extent of potential noise impact and effect; and;
- assist the delivery of sustainable development.”

While noise can override other planning concerns, neither the NPSE nor the NPPF expect noise to be considered in isolation from economic, social or other environmental dimensions of Scheme. Instead, the NPPF states that economic, social and environmental gains from the development should be sought jointly.

ProPG states that there are no specific noise levels at which noise becomes a material consideration or at which development is prohibited; instead, the decision to grant or refuse planning consent should take account of the acoustic environment and in doing so consider:

- whether or not a significant adverse effect is occurring or likely to occur
- whether or not an adverse effect is occurring or likely to occur
- whether or not a good standard of amenity can be achieved

This is consistent with the aims of the NPSE.

Two specific factors set out in PPGN, that influence whether noise could be a concern, are particularly relevant for residential development in areas subject to high levels of transportation noise. These are as follows:

- Consideration should *“be given to whether adverse internal effects can be completely removed by closing windows and, in the case of new residential developments, if the proposed mitigation relies on windows being kept closed most of the time. In both cases a suitable alternative means of ventilation is likely to be necessary”*
- *“If external amenity spaces are an intrinsic part of the overall design, the acoustic environment of those spaces should be considered so that they can be enjoyed as intended.”*

ProPG sets out a risk-based, sequential two-staged approach to address noise aspects of a Scheme. These stages are:

Stage 1 – an initial noise risk assessment of the Scheme site which should:

- provide an indication of the likely risk of adverse effects if no subsequent mitigation were to be included as part of the development plans; and
- indicate whether the proposed site is considered to pose a negligible, low, medium or high risk from a noise perspective

Stage 2 – a systematic consideration of four key elements which are:

- Element 1 – demonstrating a “Good Acoustic Design Process”
- Element 2 – observing internal “Noise Level Guidelines”
- Element 3 – undertaking an “External Amenity Area Noise Assessment”
- Element 4 – consideration of “Other Relevant Issues”

The Stage 1 Risk assessment process is outlined in Figure 2.1. It shows how noise levels are associated with an increased risk of adverse effect from noise and the pre-planning advice associated with noise levels. It should be noted that a noise risk assessment based on the daytime and night-time  $L_{Aeq}$  noise levels at a site does not form the basis of a recommendation for residential development and so this will only form part of the overall assessment.

**Figure 2.1: Stage 1 – Initial site noise risk assessment**

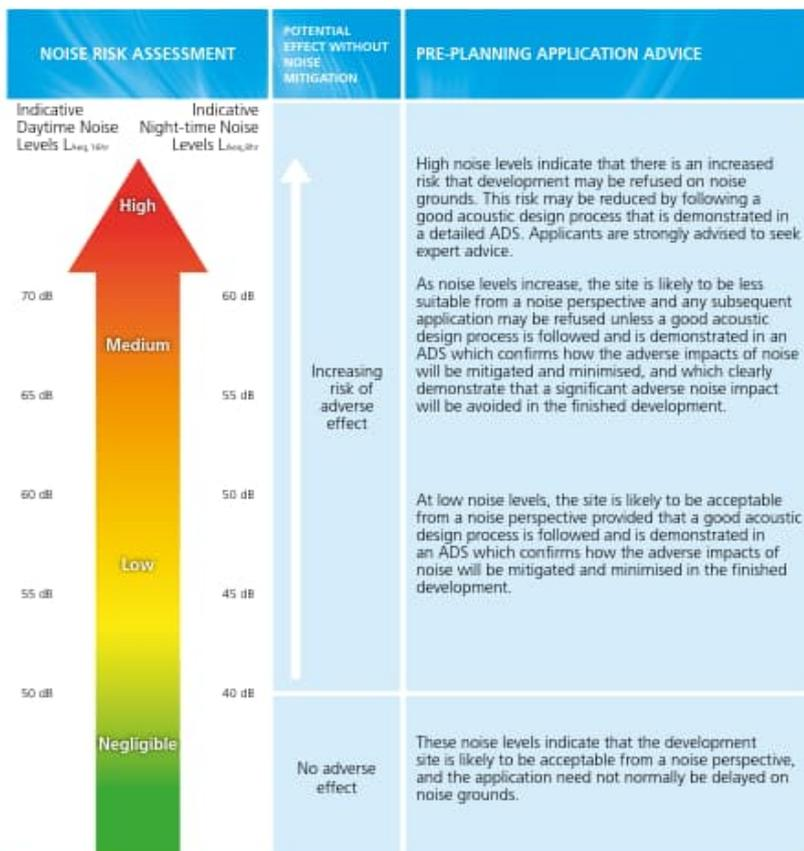

**Figure 1 Notes:**

- Indicative noise levels should be assessed without inclusion of the acoustic effect of any scheme specific noise mitigation measures.
- Indicative noise levels are the combined free-field noise level from all sources of transport noise and may also include industrial/commercial noise where this is present but is “not dominant”.
- $L_{Aeq,10hr}$  is for daytime 0700 – 2300,  $L_{Aeq,8hr}$  is for night-time 2300 – 0700.
- An indication that there may be more than 10 noise events at night (2300 – 0700) with  $L_{Aeq,t} > 60$  dB means the site should not be regarded as negligible risk.

Source: ProPG

Section 5.0 of this report addresses the initial noise risk associated with this development based on ProPG Stage 1.

## 2.5 British Standard BS 4142:2014+A1:2019

British Standard BS 4142:2014+A1:2019, titled '*Methods for rating and assessing industrial and commercial sound*', provides a method for assessing the impact of industrial noise sources on residential receivers. In this sense, industrial noise sources include mechanical plant associated with new buildings and developments.

The relevant parameters are as follows.

- Background Sound Level in  $L_{A90,T}$ ;
- Specific Sound Level, or Source Sound Level, in  $L_{Aeq,T}$ ; and
- Rating Level in  $L_{Aeq,T}$  which is the specific sound level plus any penalties given for the characteristic features of the sound.

The rating method detailed within the standard is widely accepted as an effective means of assessing the significance of building plant noise. The level of sound from proposed new plant (the overall rating level) is predicted in terms of  $L_{Aeq}$  and compared to the existing background sound level, in terms of  $L_{A90}$ . The  $L_{A90}$  is to be representative of the period being assessed. If the specific sound includes tonal, impulsive or other features likely to attract attention, assessed at the off-site noise sensitive receptors (e.g. residential), a character penalty, from 2-18 dB (although unlikely to exceed 10 dB) is added to the specific sound level. Plant that contains these character features should therefore be avoided where practical.

The outcome of the assessment is defined in BS 4142:2014+A1:2019 with the following points that relate to the difference between the background sound level and the rating level:

- Typically, the greater this difference, the greater the magnitude of the impact
- A difference of around +10dB or more is likely to be an indication of a significant adverse impact, depending on the context
- A difference of around +5dB is likely to be an indication of an adverse impact, depending on the context

The lower the rating level is relative to the measured background sound level, the less likely it is that the specific sound source will have an adverse impact or a significant adverse impact.

Where the rating level does not exceed the background sound level, this is an indication of the specific sound source having a low impact, depending on the context.

## 2.6 British Standard BS 8233:2014

British Standard BS 8233:2014 titled '*Guidance on sound insulation and noise reduction for buildings*', provides guidance for the control of noise in and around new or refurbished buildings. Within the guidance, values for the internal ambient noise levels for different building uses are recommended. It states that it is 'desirable' that internal noise levels in dwellings do not exceed 35dB  $L_{Aeq,16hr}$  in living rooms and bedrooms during the day, 40dB  $L_{Aeq,16hr}$  in dining rooms during the day and 30dB  $L_{Aeq,8hr}$  in bedrooms at night. These values are often used to inform the level of sound insulation required in the walls, glazing and ventilation at the detailed design stage of the proposed residential developments.

BS8233 provides some guidance on acceptable exterior noise levels within amenity spaces. It states: "*For traditional external areas that are used for amenity space, such as gardens and patios, it is desirable that the external noise level does not exceed 50 dB  $L_{Aeq,T}$ , with an upper guideline value of 55 dB  $L_{Aeq,T}$  which would be acceptable in noisier environments. However, it is*



*also recognized that these guideline values are not achievable in all circumstances where development might be desirable.”*

## 2.7 World Health Organization guidance

The World Health Organization (WHO) Guidelines for Community Noise and Night Noise Guidelines provides guidance on maximum noise levels within residential dwellings during night-time periods which can cause sleep disturbance. Guidance advises that internal noise levels should not exceed 45dB  $L_{Amax,f}$  (not to be exceeded 10 to 15 times a night) due to individual events.

The WHO Environmental Noise Guidelines for the European Region provides evidence-based recommendations on the health effects of noise. The guidelines complement the expert-based recommendations of the WHO ‘Night Noise Guidelines’ (2009) (NNG). Guidelines provide source specific recommendations for road traffic, railway, aircraft and wind turbine noise, and indoor as well as outdoor exposure levels for leisure noise.

## 2.8 British Standard BS 7445:2003

BS 7445:2003 ‘*Description and measurement of environmental noise*’ sets out the basic requirements for the measurement of environmental noise on site and its processing and description using the various environmental noise parameters.

## 3 Survey methodology

### 3.1 Measurement procedure

A noise survey was undertaken in December 2023 and January 2024.

The survey comprised both unattended, continuous long-term (LT) measurement and attended, short-term measurements (ST). Automatic unattended monitoring was conducted from Saturday 09 December to Thursday 21 December 2023 and attended measurements were conducted on Friday 05 January 2024.

Measurement positions were selected to be representative of the noise climate across the site and at the nearest sensitive receptors potentially subject to operational noise as a result of the development.

All equipment used for baseline noise measurements complied with Class 1 requirements given in BS EN 61672<sup>1</sup>. The sound level meters were fitted with a microphone and windshield suitable for outdoor measurement. All measurements, Short term (ST) or Long Term (LT) measurements were taken at a height of between 1.2m and 1.5m above local ground. The long term (LT) measurement was located at the southern boundary of the site.

Unless otherwise stated, all ST measurement locations were 'free-field' meaning they are at least 3.5m from an acoustically reflective façade. Measurements were completed by a Mott MacDonald acoustician competent in environment noise monitoring and completed in accordance with the principles of BS 7445<sup>2</sup>.

The calibration level of all equipment was checked before and after the measurement periods and no significant changes were noted.

Equipment was configured to measure using the fast time weighting and A-frequency weighting in 15-minute intervals for both the LT and ST measurements.

Noise levels were measured in decibels for a range of stated descriptors that are defined below.

- $L_{Amax}$  – the highest value of the A-weighted sound pressure level with a specified time weighting that occurs during a given event.
- $L_{Aeq,T}$  – also referred to as the continuous equivalent noise level, it is the A-weighted sound pressure level that is the same amount of sound energy as the time varying noise over the same period of time (T).
- $L_{A10,T}$  – the A-weighted sound pressure level that is exceeded for 10% of a given time interval (T).
- $L_{A90,T}$  – also referred to as the background noise level, it is the A-weighted sound pressure level that is exceeded for 90% of a given time interval (T).

A-weighting – As seen in the parameters above, this is a frequency weighting designed to mimic the frequency response of the human ear by providing corrections for the frequencies which the human ear is less sensitive to.

---

<sup>1</sup> BS EN 61672-1:2013 'Electroacoustics-Sound level meters Part 1: Specifications.'

<sup>2</sup> British Standards Institution BS 7445 Description and measurement of environmental noise. Part 1: Guide to quantities and procedures, 2003,

### 3.2 Measurement locations

Measurement locations and details are provided in Figure 3.1 and Table 3.1.

**Figure 3.1: Noise measurement locations**



Source: © OpenStreetMap contributors (data is available under the Open Database Licence, <https://www.openstreetmap.org/copyright>) with Mott MacDonald mark-up

**Table 3.1: Noise measurement location details**

Measurement ID	Measurement type	Microphone height from existing ground (m)
LT1	Free field	1.2m / 1.5m
ST1	Free field	1.2m
ST2	Free field	1.2m
ST3	Free field	1.2m

Measurement ID	Measurement type	Microphone height from existing ground (m)
ST4	Free field	1.2m

Source: Mott MacDonald and <https://what3words.com>

### 3.3 Equipment

A full inventory of all equipment used during the baseline noise surveys is shown in Table 3.2

**Table 3.2: Inventory of noise measurement equipment**

Item	Model	Serial Number	Calibrated until
LT	Rion NL-52	1265460	14/07/2024
ST	Rion NL-52	1176426	04/05/2024
Calibrator	Rion NC75	34913591	21/02/2023

Source: Mott MacDonald

### 3.4 Weather conditions

The weather conditions during the attended survey (ST measurements and installation) were considered suitable for undertaking noise measurements.

Weather conditions were measured at LT1 during the survey and reported below.

During the automatic unattended noise survey there were periods when wind speeds exceeded 5m/s and periods which were subject to rain. These periods have been excluded during the processing of the measured noise data.

Table 3.3 presents details of the weather conditions.

**Table 3.3: Weather summary**

Date	Average Temp (Degrees C)	Average Wind Speed (m/s)	Average Rainfall (mm)
09/12/2023			
10/12/2023	10	2	0
11/12/2023	10	2	0
12/12/2023	10	1	0
13/12/2023	10	2	0
14/12/2023	6	2	0
15/12/2023	6	0	0
16/12/2023	6	1	0
17/12/2023	10	2	0
18/12/2023	10	3	0
19/12/2023	11	3	0
20/12/2023	9	1	0
21/12/2023	9	2	0

Source: Mott MacDonald

### 3.5 Limitations

Inevitably there is a degree of variation in measured noise levels. Contributory factors to this variation include tolerances in instrumentation readings, meteorological conditions, and the inherent difference in the acoustic environment during the course of the day and indeed over

longer periods as the noise sources influencing a given location vary. Every effort has been made to limit variation in the measurements reported. The following efforts have been made in order to reduce measurement uncertainty.

- Undertaking surveys with appropriately qualified and trained acoustic engineers
- Use of measurement equipment calibrated to appropriate standards by accredited bodies and checked on site using calibrated reference sound sources
- Following best practice methodology for environmental noise measurement set out in BS 7445
- Measuring under appropriate meteorological conditions
- Measuring at times and locations that are representative of the noise climate at any particular location
- Analysing the data to notice trends and anomalies, ensuring the data is representative for the location

## 4 Measurement results

This section presents the full data results for both Long-Term (LT) and Short-term (ST) noise measurements.

For the purposes of the assessment, only the  $L_{Aeq}$  and  $L_{A90}$  parameters are presented for the LT measurements and  $L_{Aeq}$  for the ST measurements.

LT  $L_{Aeq}$  noise measurements are shown for daytime (07:00 to 23:00), and night-time (23:00 to 07:00) in accordance with guidance provided by TAN 11 and BS 4142.

LT  $L_{A90}$  noise measurements have been analysed to determine a single number value which is considered to be the representative background noise level during the relevant assessment periods in accordance with guidance provided by BS 4142. In this case the lowest 10<sup>th</sup> percentile value of the  $L_{A90,15min}$  values has been used.

### 4.1 Long term

Position LT1 was located near to vegetation at the edge of the field next to a residential property. It was installed at 11:01 on 09 December 2023 and collected at 10:01 on 21 December 2023.

The major noise source was road traffic noise from the M48 and Crick Road.

The levels relevant to the assessment are summarised in Table 4.1 below. Figure 4.1 shows the time history of the measurement.

All levels have been rounded to the nearest whole number. Partial measurement periods at the start and end of the survey have been included (shown with one asterisk).

**Table 4.1: LT1 measurement results (free-field measurement)**

	Average $L_{Aeq, T}$ dB		$L_{A90, T}$ dB	
	Day (07:00-23:00)	Night (23:00-07:00)	Day (07:00-23:00)	Night (23:00-07:00)
9 December 2023	58.1	50.0	48.7	35.2
10 December 2023	57.3	54.5	47.5	36.7
11 December 2023	56.9	53.3	46.2	41.7
12 December 2023	57.4	55.9	49.9	44.4
13 December 2023	58.5	54.6	49.5	46.6
14 December 2023	56.5	55.6	49.6	48.5
15 December 2023	56.1	51.1	47.2	36.2
16 December 2023	55.0	49.2	45.0	37.7
17 December 2023	54.0	51.8	44.6	37.6
18 December 2023	57.0	54.7	50.1	39.8
19 December 2023	58.4	54.5	48.6	36.4
20 December 2023	57.3	55.3	47.7	38.7
21 December 2023				
<b>Baseline level for assessment</b>	<b>56.9</b>	<b>53.4</b>	<b>47.9</b>	<b>40.0</b>

**Figure 4.1: LT1 plot of results of the long term noise monitoring**

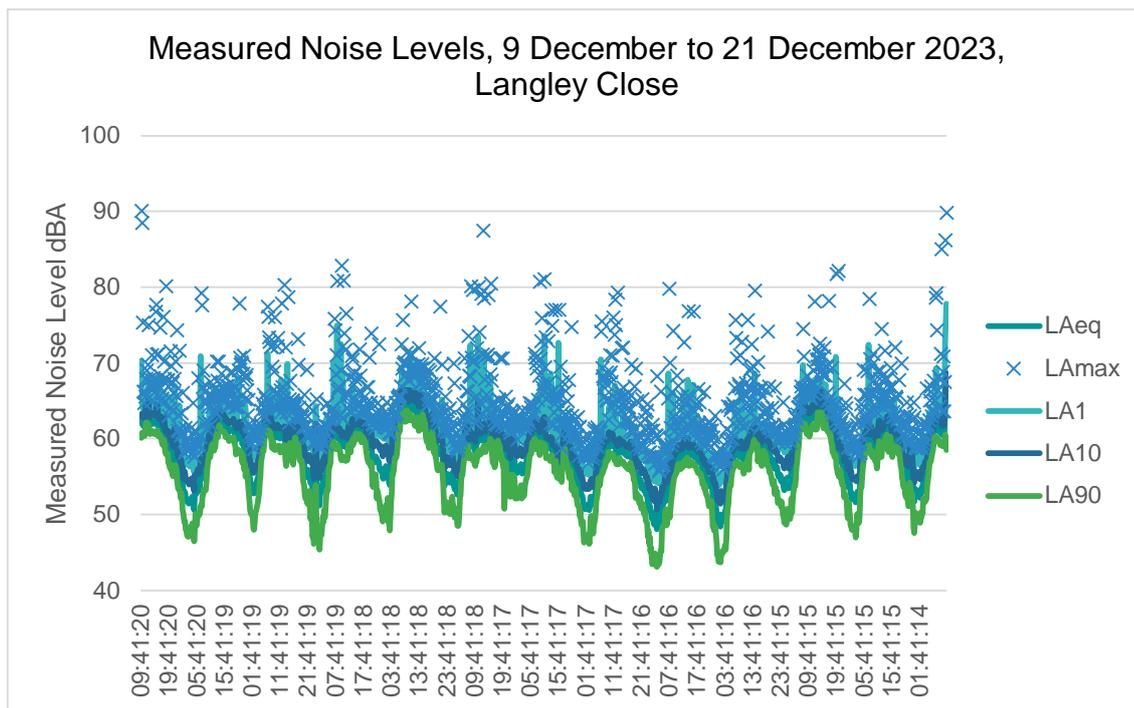

**4.2 Short term**

The noise climate of these measurement positions was dominated by road traffic noise from the M48 motorway and Crick Road.

In order to determine the geographical variation in noise level across the site relative to the measured noise levels at LT1 an automatic unattended noise logger was set up at LT1 during the attended measurements. This was set up such that 5-minute samples at the ST locations

were synchronous with the 5 minute samples at LT1. The difference between the measured  $L_{Aeq, 5 \text{ minute}}$  samples were then used to estimate the  $L_{Aeq, 16hr}$  and  $L_{Aeq, 8hr}$  at the ST locations. This comparison is shown in Appendix B. The principle of using a long term measurement to estimate measurement parameters at short term measurement locations is set out in Dept of Transports document: The Calculation of Road Traffic Noise, Comparative Method, para 45.

The supplementary ST noise levels and comments on the main noise sources are summarised in Table 4.2 below.

All levels have been rounded to the nearest whole number.

**Table 4.2: Summary of ST measurements (5 minutes for each measurement)**

ST	Date	Start time	$L_{Aeq, T}$ dB	$L_{Amax, T}$ dB	$L_{A10, T}$ dB	$L_{A90, T}$ dB	Main noise source and comments
SW	9 January 2024	10:55	62.6	87.5	64.2	50.3	Traffic noise form A48, Intermittent traffic on Crick Road.
SW	9 January 2024	11:00	60.6	85.8	64.1	49.3	Traffic noise form A48, Intermittent traffic on Crick Road.
SW	9 January 2024	11:50	60	74	64.2	50.1	Traffic noise form A48, Intermittent traffic on Crick Road.
SW	9 January 2024	11:55	57.6	73.8	62.1	49.2	Traffic noise form A48, Intermittent traffic on Crick Road.
			60.2				
SE	9 January 2024	11:10	54.3	72.4	55.9	51	Traffic noise form A48, Intermittent traffic on Crick Road.
SE	9 January 2024	11:15	54.9	70.7	56.6	51.7	Traffic noise form A48, Intermittent traffic on Crick Road.
SE	9 January 2024	12:10	55.9	64.3	57.8	53.1	Traffic noise form A48, Intermittent traffic on Crick Road.
SE	9 January 2024	12:15	56.6	66	58.8	52.9	Traffic noise form A48, Intermittent traffic on Crick Road.
			55.4				
NE	9 January 2024	11:25	57.6	62.9	60.1	53.3	Traffic noise form A48, Intermittent traffic on Crick Road.
NE	9 January 2024	11:30	58.5	67.5	61.2	52.8	Traffic noise form A48, Intermittent traffic on Crick Road.
NE	9 January 2024	12:20	59.7	66.2	62	56.4	Traffic noise form A48, Intermittent traffic on Crick Road.
NE	9 January 2024	12:25	58.8	67.2	61	54.3	Traffic noise form A48, Intermittent traffic on Crick Road.
			58.65				
NW	9 January 2024	11:35	58	65.5	60.5	53.7	Traffic noise form A48, Intermittent traffic on Crick Road.
NW	9 January 2024	11:40	59.3	66.1	61.9	53.4	Traffic noise form A48, Intermittent traffic on Crick Road.
NW	9 January 2024	12:30	60	69	62.9	54.4	Traffic noise form A48, Intermittent traffic on Crick Road.
NW	9 January 2024	12:35	60.7	71	63.1	56.5	Traffic noise form A48, Intermittent traffic on Crick Road.
			59.5				



## 5 Assessment

### 5.1 TAN 11

The measured  $L_{Aeq,16hr}$  and  $L_{Aeq,8hr}$  values at each of the measurement locations have been used to determine which areas of the site are within the NEC Categories shown in Table 2.3. These areas have been drawn in Figure 5.1 below:

Figure 5.1: Areas within TAN 11 NEC Categories

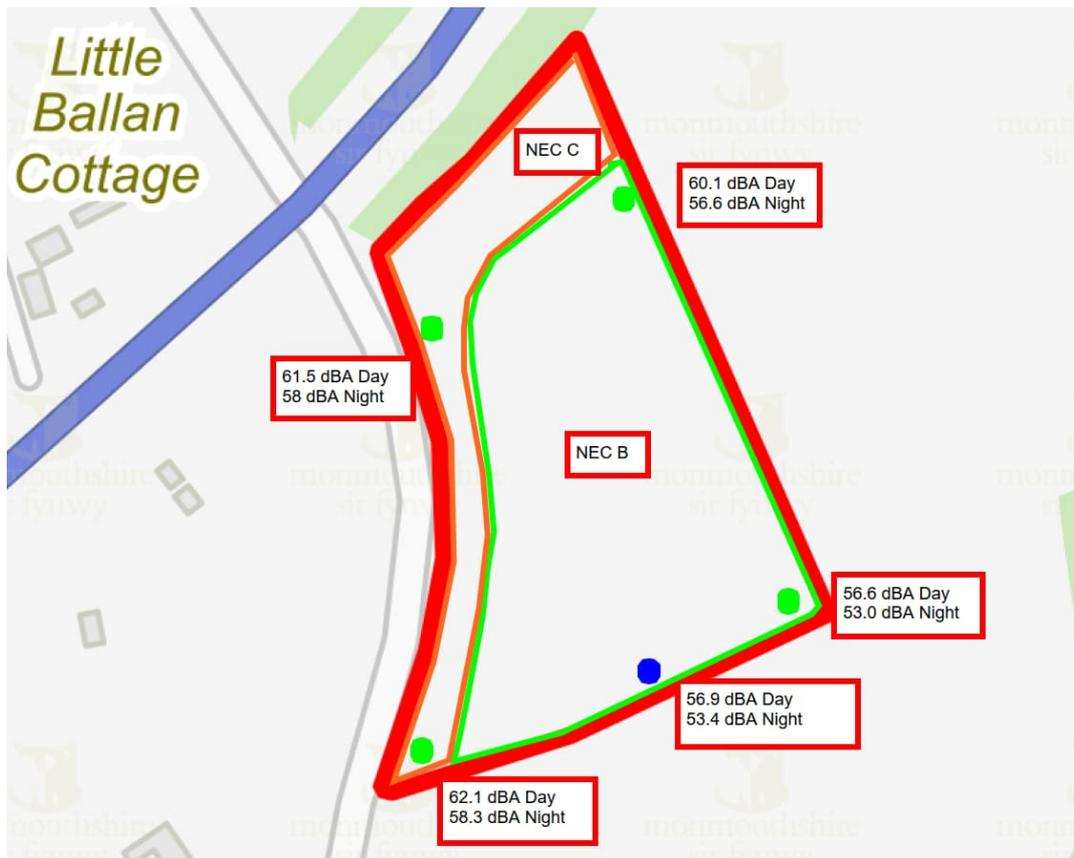

Source: Mott MacDonald

### 5.2 ProPG

Measured  $L_{Aeq}$  Levels on site at LT1, were 56.9dBL $_{Aeq,16hr}$  during daytime and 53.4dBL $_{Aeq,8hr}$  at night. Comparing these levels with the chart shown in Figure 1 indicates that the ProPG Stage 1 Risk assessment methodology would assign a 'Medium' risk during daytime and night.

Calculated  $L_{eq,16hour}$  levels were up to 61.5dB at the long term measurement position and up to 58.0dB at the short term measurement locations closest to the A48 and Crick Road. These monitoring locations were approximately 10m from the edge of Crick Road and approximately 40m from the M48 motorway. Comparing these levels with the chart shown in Figure 2.1 indicates that the ProPG Stage 1 Risk assessment methodology would assign a 'Medium' risk during daytime and "medium/high" risk at night.

Calculated  $L_{eq,16hour}$  levels in the south eastern corner of the site were 56.6dB during daytime and 53.0dB at night. Comparing these levels with the chart shown in Figure 2.1 indicates that the ProPG Stage 1 Risk assessment methodology would assign a 'Low' risk during daytime and "Low/medium" risk at night.

ProPG is generally aimed at developments of substantial bricks and mortar or other relatively massive constructions. The Gypsy and Traveller site would however accommodate mobile homes. These have lower sound insulation values than more substantial homes and this needs to be taken into account.

BS 8233 states that it is 'desirable' that internal noise levels in dwellings do not exceed 35dB  $L_{Aeq,16hr}$  in living rooms and bedrooms during the day, 40dB  $L_{Aeq,16hr}$  in dining rooms during the day and 30dB  $L_{Aeq,8hr}$  in bedrooms at night. It is estimated that a mobile home may provide a sound insulation value of around 15dB to 20dB with windows closed.

Based on the measured noise levels in the southeastern corner of the site, internal levels would be estimated to be around 41dB  $L_{Aeq,16hr}$  during daytime and 38dB  $L_{Aeq,8hr}$  at night. These are marginally above the internal noise level recommendations provided by BS 8233. At other parts of the site the exceedances of internal noise criteria are higher.

In order to achieve the internal noise levels within mobile homes recommended by BS 8233 by distance attenuation alone would not be feasible. It would however be possible to construct an earth bund along the western boundary of the site which would significantly attenuate noise levels from Crick Road. Noise levels from the M48 motorway would be more difficult to attenuate due to the elevation of the carriageway. If the southern part of the site were developed it may be possible to construct an earth bund or barrier across the middle of the site to provide attenuation.

It is therefore considered that the south-eastern part of the site may be suitable for development as a Gypsy and Traveler Site provided mitigation measures are implemented.

### 5.3 BS 4142

There are not expected to be any major noise sources associated with the Gypsy and Travellers site, but minor plant such as toilet extract fans, generators and air conditioning units etc may potentially be expected.

Background  $L_{A90}$  noise levels of 47.9dB during daytime and 40dB during night-time were measured on site. BS 4142 state that "where the rating level does not exceed the background sound level, this is an indication of the specific sound source having a low impact, depending on the context" and the background noise level is often used as a noise limit for noise emissions from new developments.

It is therefore recommended that noise levels created by any plant associated with the proposed Gypsy and Traveller site should be limited to 48dB during daytime 40dB  $L_{Aeq,8hr}$  at the nearest potentially affected residences providing a 5dB margin of compliance with internal noise criteria.

BS 8233 provides some guidance on acceptable exterior noise levels within amenity spaces. Its states: "it is desirable that the external noise level does not exceed 50 dB  $L_{Aeq,T}$ , with an upper guideline value of 55 dB  $L_{Aeq,T}$  which would be acceptable in noisier environments."

The measured noise levels at LT1, and ST1 to ST4 all exceeded 50 dB  $L_{Aeq,T}$ .

It would therefore be advisable to provide localised noise screening for the outdoor amenity areas within the site. This may take the form of solid noise barriers or landscaped bunds between the road and the residential plots of the site. As described above this would probably need to run along the western boundary with Crick Road and across the middle of the site.

## 6 Conclusions

This report documents the findings of the noise monitoring and assessment undertaken for the proposed Gypsy and Traveller site at Bradbury Farm.

Applying TAN11 shows that area closest to the M48 motorway falls within NEC C in which *'Planning permission should not normally be granted. Where it is considered that permission should be given, for example, because there are no alternative quieter sites available, conditions should be imposed to ensure a commensurate level of protection against noise.'*

Beyond approximately 60m from the M48 motorway and 20m of Crick Road the site falls within NEC B in which *'Noise should be taken into account when determining planning applications and, where appropriate, conditions imposed to ensure an adequate level of protection'*.

Measured noise levels have also been used to assess the risk of noise having an adverse impact upon the site in accordance with the ProPg stage 1 Risk Assessment method. This assessment shows there is a *Medium/High* risk of noise adversely impacting the north western part of the site closest to the M48 motorway and Crick Road. In the south eastern part of the site however there is a *Low/Medium* risk according to ProPG.

However, the above guidance is intended primarily to deal with dwellings which are constructed from bricks and mortar. Mobile homes provide significantly lower levels of sound attenuation between exterior and interior. It is estimated that a mobile home may provide a sound insulation value of around 15dB to 20dB with windows closed.

Based on the levels of noise measured on the site interior noise levels would exceed the recommended noise levels given in BS 8233 across the whole site. However, if an earth bund or solid noise barrier were constructed along the northern edge of the site this may provide sufficient sound attenuation that the internal noise criteria recommended by BS 8233 would be met within mobile homes on the southern part of the site.

A noise level limit of 48dB  $L_{Aeq,1hr}$  during daytime and 40dB  $L_{Aeq,15min}$  at night are proposed for fixed plant noise emissions from the site.

Exterior noise levels on the site would exceed dB  $L_{Aeq,T}$  during daytime. It would therefore be advisable to provide localised noise screening for the outdoor amenity areas or a barrier/bund along the northern boundary of the site closest to the M48 motorway.

If planning permission is granted, a Stage 2 Acoustic Assessment should be conducted in which the landscape design of the proposed site should be developed to incorporate acoustic screening for the plots closest to the north-eastern corner.

## A. Acoustic Glossary

<b>A-weighting</b>	The human ear also has a non-linear frequency response, being most sensitive in the frequency range 1 kHz to 4 kHz and is less sensitive at higher and lower frequencies. The A-weighting is a frequency function commonly applied to the linear output of a microphone to simulate the subjective response of the ear. A-weighted levels are usually indicated by a subscript A or postscript (A).
<b>Z-weighting</b>	A flat frequency response between 10Hz and 20kHz excluding microphone response.
<b>Decibel</b>	Sound and noise are commonly described using the decibel (dB) scale, which is logarithmic in nature to relate to the response of the human ear. The range of human hearing commonly varies from the threshold of audibility (0dB) to the threshold of pain (120dB). Such limits are seldom experienced in practice and typical levels might vary between 30dB in a quiet bedroom at night to 90dB at the kerbside of a busy road.
<b>Sound Pressure Level (Lp)</b>	The logarithmic measure of the root mean square sound pressure relative to a reference sound pressure. The reference sound pressure in air is 20 micro Pascals and represents the threshold of hearing in a healthy young person.
<b>Equivalent continuous noise level Leq</b>	The equivalent continuous noise level, $L_{Aeq,T}$ , is the notional level of a steady sound which, at a given position and over the same period of time (T), would deliver the same sound energy as the fluctuating one. Used to quantify time-varying noise from industrial sources.
<b>Maximum sound pressure level L(max)</b>	The lowest sound pressure level reached within the measurement period.
<b>Minimum sound pressure level L(min)</b>	The lowest sound level reached within the measurement period.
<b>Ln</b>	A statistical parameter where the sound pressure level exceeded for a 'n' percentage of the measurement period.
<b>Fast weighting</b>	The sound pressure level is weighted to the response time of the ear (125ms).
<b>Slow weighting</b>	The sound pressure level is weighted to the response time of 1 second.

## B Comparison between 5 minute sample measurements at ST and LT locations.

	Time	LAeq	LAmaz	LA10	LA90	Difference LAeq	Time	LAeq	LAmaz	LA10	LA90
SW	10:55	62.6	87.5	64.2	50.3	7.1	10:55	55.5	62.6	57.6	52.5
SW	11:00	60.6	85.8	64.1	49.3	5.7	11:00	54.9	59.3	57.1	51.9
SW	11:50	60	74	64.2	50.1	5.5	11:50	54.5	61.2	56.6	51.4
SW	11:55	57.6	73.8	62.1	49.2	2.6	11:55	55	60.4	56.8	51.7
		60.2				5.225					
	Time	Leq	Lmax	LA10	LA90	Difference LAeq	Time	Leq	Lmax	LA10	LA90
SE	11:10	54.3	72.4	55.9	51	-0.3	11:10	54.6	62.4	56.6	51.3
SE	11:15	54.9	70.7	56.6	51.7	0.1	11:15	54.8	63	56.7	51.9
SE	12:10	55.9	64.3	57.8	53.1	-0.2	12:10	56.1	64	58.3	52.3
SE	12:15	56.6	66	58.8	52.9	-1.3	12:15	57.9	72.2	58.9	53.3
		55.425				-0.425					
	Time	Leq	Lmax	LA10	LA90	Difference LAeq	Time	Leq	Lmax	LA10	LA90
NE	11:25	57.6	62.9	60.1	53.3	2.6	11:25	55	61.3	57.3	51.2
NE	11:30	58.5	67.5	61.2	52.8	2.6	11:30	55.9	64.5	58.9	51.5
NE	12:20	59.7	66.2	62	56.4	4.1	12:20	55.6	59.8	57.2	53.4
NE	12:25	58.8	67.2	61	54.3	3.4	12:25	55.4	61.5	57.4	52.1
		58.65				3.175					
	Time	Leq	Lmax	LA10	LA90	Difference LAeq	Time	Leq	Lmax	LA10	LA90
NW	11:35	58	65.5	60.5	53.7	3.9	11:35	54.1	58.3	56	51.5
NW	11:40	59.3	66.1	61.9	53.4	4.6	11:40	54.7	58.1	56.5	51.6
NW	12:30	60	69	62.9	54.4	5.4	12:30	54.6	63.4	56.5	52.1
NW	12:35	60.7	71	63.1	56.5	4.4	12:35	56.3	62.1	58.5	53.1
		59.5				4.575					





# **Proposed Gypsy and Traveller Site, Langley Close, Magor**

Noise Assessment

February 2024

Confidential

This page left intentionally blank for pagination.



Mott MacDonald  
10 Temple Back  
Bristol BS1 6FL  
United Kingdom

T +44 (0)117 906 9500  
mottmac.com

# **Proposed Gypsy and Traveller Site, Langley Close, Magor**

Noise Assessment

February 2024

Confidential

# Issue and Revision Record

Revision	Date	Originator	Checker	Approver	Description
0	09/02/24	R Roper	A Monk-Steel	R Perkins	First draft for client comment

**Document reference:** 100115516 | NS001 | P01 | 100115516

**Information class:** Standard

This document is issued for the party which commissioned it and for specific purposes connected with the above-captioned project only. It should not be relied upon by any other party or used for any other purpose.

We accept no responsibility for the consequences of this document being relied upon by any other party, or being used for any other purpose, or containing any error or omission which is due to an error or omission in data supplied to us by other parties.

This document contains confidential information and proprietary intellectual property. It should not be shown to other parties without consent from us and from the party which commissioned it.

# Contents

<b>1</b>	<b>Introduction</b>	<b>1</b>
1.1	Project description	1
1.2	Site description	1
1.3	Scope of the assessment	2
<b>2</b>	<b>Guidance and legislation</b>	<b>4</b>
2.1	Planning Policy Wales	4
2.2	Local authority policy and guidance	5
2.3	TAN 11	6
2.4	ProPG	8
2.5	British Standard BS4142:2014+A1:2019	10
2.6	British Standard BS 8233:2014	10
2.7	World Health Organization guidance	11
2.8	British Standard BS 7445:2003	11
<b>3</b>	<b>Survey methodology</b>	<b>12</b>
3.1	Measurement procedure	12
3.2	Measurement locations	13
3.3	Equipment	13
3.4	Weather conditions	14
3.5	Limitations	14
<b>4</b>	<b>Measurement results</b>	<b>15</b>
4.1	Long term	15
4.2	Short term	16
<b>5</b>	<b>Assessment</b>	<b>18</b>
5.1	TAN 11	18
5.2	ProPG	18
5.3	BS 4142	19
5.4	BS 8233	20
<b>6</b>	<b>Conclusions</b>	<b>21</b>
<b>A.</b>	<b>Acoustic Glossary</b>	<b>22</b>

## B Comparison between 5 minute sample measurements at ST and LT locations 23

### Tables

Table 3.1: Noise measurement location details	13
Table 3.2: Inventory of noise measurement equipment	13
Table 3.3: Weather summary	14
Table 4.1: LT1 measurement results (free-field measurement)	16
Table 4.2: Summary of ST measurements (15 minutes for each measurement)	17

### Figures

Figure 1.1: Proposed site layout	2
Figure 4.1: LT1 plot of results of the long term measurement	16

# 1 Introduction

## 1.1 Project description

Monmouthshire County Council (MCC) has a legal and moral duty to ensure everyone has access to good quality homes. MCC recognises that safe, culturally-appropriate accommodation is necessary for individuals to flourish in other parts of their lives. In accordance with the Housing (Wales) Act, 2014, MCC has identified a need for additional sites to house the Gypsy and Traveller families already living in Monmouthshire.

Three Council owned sites in Monmouthshire have been identified as potentially suitable to meet the current needs for the Gypsy and Traveller community. Mott MacDonald was commissioned by MCC to conduct noise surveys and assessments at proposed development sites in Monmouthshire at:

- Langley Close, Magor,
- Land at Bradbury Farm, Crick; and
- Land at Oak Grove Farm, Portskewett.

It is proposed to develop one of these sites as a Gypsy and Travellers site.

Mott MacDonald has been appointed by MCC to provide a noise assessment report as part of MCC's Gypsy and Traveller Accommodation Assessment (GTAA) identification study for the Langley Close, Magor, Monmouthshire (hereafter referred to as "**the proposed Gypsy and Traveller site**" or simply "the site"), one of the three council-owned identified sites for potential development.

This report describes the noise impact assessment for the proposed development at Langley Close and assesses the potential impact on the development due to existing noise levels and sets criteria for any noise emissions from the site.

## 1.2 Site description

The site currently comprises three grazed agricultural fields south of the west bound off ramp of the M4 motorway Junction 23A to the Magor Interchange with the A4810 road which is to the west of the site but separated from it by further fields. Immediately to the south of the site are the residential areas of Langley Close and an unnamed cul de sac off the B4245 Newport Road.

The proposed Gypsy and Travellers site is understood to comprise the construction of up to six pitches that will include parking and a collective utility block with access gained via St Brides Road which runs along the eastern boundary of the site.

The noise environment on the site is dominated by traffic noise from the M4 motorway and the off ramps to Magor Interchange. Intermittent vehicle noise occurs from St Brides Road but this is negligible in comparison with that from the M4.

The site layout is shown in Figure 1.1.

**Figure 1.1: Proposed site layout**

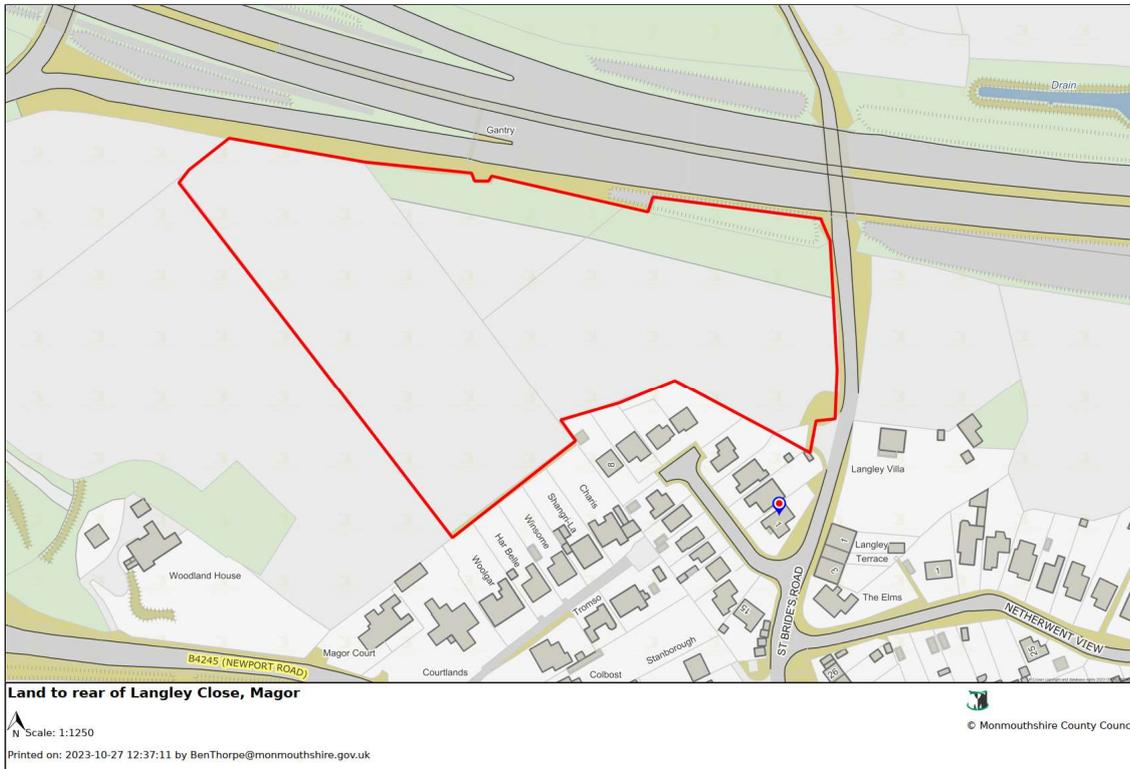

Source: Monmouthshire County Council

### 1.3 Scope of the assessment

The purpose of the survey was to quantify the ambient noise levels impacting the site and the background sound levels at the nearby noise sensitive receptors (NSRs).

The suitability of the proposed site is considered using Technical Advice Note, TAN 11: Noise (1997), Professional Practice Guidance on Planning and Noise (ProPG) with due consideration to Technical Advice Note 11: Air Quality, Noise and Soundscape' (2022) and 'Supporting Document 1: Soundscape Design' (2022).

Noise levels due to existing noise sources potentially impacting the proposal are assessed in terms of the implications for the internal noise levels within a typical mobile home using British Standard (BS) 8233 (2014) 'Guidance on sound insulation and noise reduction for buildings'. As the type and construction of these mobile homes will vary this will be indicative only. Any outline mitigation measure proposed will be aimed at the layout and landscaping of the site as the design of mobile homes is clearly beyond the control of the designers. At the time of this report the proposed layout of the site is not known and therefore the proposed mitigation measures are only discussed in outline.

Environmental noise limits for any proposed new plant associated with the development, such as toilet extract fans or generators, would be set in accordance with the guidance in BS 4142 (2014+A1:2019) 'Methods for rating and assessing industrial and commercial sound', in the context of the TAN 11, Planning Policy Wales and any specific local authority requirements.

This report details the monitoring methodology, noise assessment methodology and any assumptions and limitations associated with the monitoring, and documents the results of the baseline monitoring.

The baseline monitoring data has been processed in accordance with the requirements of BS 4142 in order to set criteria for noise emissions from any mechanical plant such as toilet extracts, generators, air-conditioning units etc associated with the proposed development.

The baseline monitoring data has also been processed in accordance with British Standard BS 7445 (2003) '*Description and measurement of environmental noise*' and BS 8233 (2014) '*Guidance on sound insulation and noise reduction for buildings*'.

## 2 Guidance and legislation

### 2.1 Planning Policy Wales

Planning Policy Wales (PPW) points out some similarities between air quality and noise in the way they impact a proposed site. Noise is not just considered in terms of its level. PPW also discusses the 'soundscape'. Selected sections of Planning Policy Wales, Edition 11 | February 2021 are reproduced below:

#### **Air Quality and Soundscape**

*6.7.1 Clean air and an appropriate soundscape, contribute to a positive experience of place as well as being necessary for public health, amenity and well-being. They are indicators of local environmental quality and integral qualities of place which should be protected through preventative or proactive action through the planning system. Conversely, air, noise and light pollution can have negative effects on people, biodiversity and the resilience of ecosystems and should be reduced as far as possible.*

*6.7.3 Certain sounds, such as those created by trees, birds or water features, can contribute to a sense of tranquillity whilst others can be reassuring as a consequence of their association with the normality of everyday activities. Problematic forms of sound are generally experienced as noise pollution and can affect amenity and be prejudicial to health or a nuisance.*

*6.7.4 The planning system should maximise its contribution to achieving the well-being goals, and in particular a healthier Wales, by aiming to reduce average population exposure to air and noise pollution alongside action to tackle high pollution hotspots. In doing so, it should consider the long-term effects of current and predicted levels of air and noise pollution on individuals, society and the environment and identify and pursue any opportunities to reduce, or at least, minimise population exposure to air and noise pollution, and improve soundscapes, where it is practical and feasible to do so.*

*6.7.5 In taking forward these broad objectives the key planning policy principle is to consider the effects which proposed developments may have on air or soundscape quality and the effects which existing air or soundscape quality may have on proposed developments. Air Quality and soundscape influence choice of location and distribution of development and it will be important to consider the relationship of proposed development to existing development and its surrounding area and its potential to exacerbate or create poor air quality or inappropriate soundscapes. The agent of change principle says that a business or person responsible for introducing a change is responsible for managing that change. In practice, for example, this means a developer would have to ensure that solutions to address air quality or noise from nearby pre-existing infrastructure, businesses or venues can be found and implemented as part of ensuring development is acceptable.*

*6.7.6 In proposing new development, planning authorities and developers must, therefore:*

- *address any implication arising as a result of its association with, or location within, air quality management areas, noise action planning priority areas or areas where there are sensitive receptors*
- *not create areas of poor air quality or inappropriate soundscape; and*
- *seek to incorporate measures which reduce overall exposure to air and noise pollution and create appropriate soundscapes.*



*To assist decision making it will be important that the most appropriate level of information is provided and it may be necessary for a technical air quality and noise assessment to be undertaken by a suitably qualified and competent person on behalf of the developer.*

*6.7.8 Good design, for example setting back buildings from roads to avoid canyon effects and using best practice in terms of acoustic design to ensure the appropriate and intended acoustic environment of completed developments should be incorporated at an early consideration in the design and planning process.*

## 2.2 Local authority policy and guidance

Langley Close falls under the ‘Monmouthshire County Council Adopted Local Development Plan 2011-2021’ which was adopted 27 February 2014 and sets out the plans, visions and policies for development.

*6.3.60 Policy EP1 seeks to prevent development proposals that would result in unacceptable risk or harm due to air, light, noise or water pollution, contamination or land instability.*

### **EP1 - Amenity and Environmental Protection**

*Development, including proposals for new buildings, extensions to existing buildings and advertisements, should have regard to the privacy, amenity and health of occupiers of neighbouring properties. Development proposals that would cause or result in an unacceptable risk /harm to local amenity, health, the character /quality of the countryside or interests of nature conservation, landscape or built heritage importance due to the following will not be permitted, unless it can be demonstrated that measures can be taken to overcome any significant risk:*

- .....
- Noise pollution;

.....

The Replacement Local Development Plan (RLDP) – (2018 to 2033) includes the ‘Replacement Local Development Plan Sustainability Appraisal Scoping Report Appendix 1 – Review of Plans, Policies, Programmes and Strategies November 2022, in which Monmouthshire Council includes the following section of table:

**Table 2.1 Selected Section of Table Sustainability Appraisal Scoping Report Appendix 1 – Review of Plans, Policies, Programmes and Strategies**

<b>ISA Theme: Health &amp; Well-being</b>	
<b>International, European, National (UK), National Wales</b>	
Planning Policy Wales Edition 11 (2021) Technical Advice Note (TAN) 11: Noise (1997) (Revised TAN currently being consulted on by WG) Technical Advice Note (TAN) 16: Sport, recreation and open space (2009)	<i>Planning Policy Wales (PPW) sets out the land use planning policies of the Welsh Government. It is supplemented by a series of Technical Advice Notes. It translates our commitment to sustainable development into the planning system so that it can play an appropriate role in moving towards sustainability. Planning Policy Wales (PPW) puts a commitment to achieving the Well-being goals of the Well-being of Future Generations Act at the centre of the planning system in Wales. PPW notes that planning</i>

---

*authorities have a role to play in the prevention of physical and mental illnesses caused by pollution, isolation from society and activities, and must consider the impact of new development on communities and prioritise health protection. It requires planning authorities to:*

- Contribute to the protection and, where possible, the improvement of people’s health and wellbeing as a core component of achieving the well-being goals and responding to climate change.*
  - Consider the possible impacts of developments – positive and/or negative – on people’s health at an early stage will help to clarify the relevance of health and the extent to which it needs to be considered.*
  - Ensure, as far as is practicable, that noise-sensitive developments, such as hospitals, schools, and housing, that need to be located close to the existing transportation infrastructure to facilitate access, are designed in such a way as to limit noise levels within and around those developments.*
  - Consider national air quality objectives, recognising that they represent a pragmatic threshold above which government considers the health risks associated with air pollution are unacceptable.*
- 

### 2.3 TAN 11

Planning Policy Wales is supplemented by a series Technical Advice Notes (TAN) that provide detailed planning advice on different subjects. TAN 11: Noise (1997) provides a methodology for assessing the suitability of a site for residential development near existing sources of noise. It provides threshold noise levels for Noise Exposure Categories (NECs), which determine the suitability of the site for residential development and within which various levels of consideration to mitigation should be given. These noise exposure categories are provided for road, rail, aircraft and mixed sources. Separate noise level ranges are specified for the day-time and night-time periods for each of the NECs. The degree of consideration required for each Noise Exposure Category is described in Table 2.2 below.

**Table 2.2: Noise exposure categories for dwellings**

<b>Noise Exposure Categories</b>	
A	Noise need not be considered as a determining factor in granting planning permission, although the noise level at the high end of the category should not be regarded as desirable.
B	Noise should be taken into account when determining planning applications and, where appropriate, conditions imposed to ensure an adequate level of protection.

---

### Noise Exposure Categories

C	Planning permission should not normally be granted. Where it is considered that permission should be given, for example, because there are no alternative quieter sites available, conditions should be imposed to ensure a commensurate level of protection against noise.
D	Planning permission should normally be refused.

Source: TAN11, Annex A, Table 1

The noise level ranges of the various categories are shown in Table 2.3 below.

### Noise Table 2.3: Recommended Noise Exposure Categories (NEC) for new dwellings near existing noise sources

Noise levels<sup>(1)</sup> corresponding to noise exposure categories in  $L_{Aeq, T}$  dB

Noise source	Time period	Noise exposure category			
		A	B	C	D
Road traffic	Day time 07:00 to 23:00	< 55	55-63	63-71	> 72
	Night time 23:00 to 07:00 <sup>(2)</sup>	< 45	45-57	57-66	> 66
Rail traffic	Day time 07:00 to 23:00	< 55	55-66	66-74	> 74
	Night time 23:00 to 07:00 <sup>(2)</sup>	< 45	45-59	59-66	> 66
Air traffic <sup>(3)</sup>	Day time 07:00 to 23:00	< 57	57-66	66-72	> 72
	Night time 23:00 to 07:00 <sup>(2)</sup>	< 48	48-57	57-66	> 66
Mixed sources <sup>(4)</sup>	Day time 07:00 to 23:00	< 55	55-63	63-72	> 72
	Night time 23:00 to 07:00 <sup>(2)</sup>	< 45	45-57	57-66	> 66

**Notes**

<sup>(1)</sup> Noise levels: the noise level(s) ( $L_{Aeq, T}$ ) used when decided the NEC of a site should be representative of typical conditions.

<sup>(2)</sup> Night-time noise levels (2300-0700): sites where individual noise events regularly exceed 82 dB  $L_{Amax}$  (S time weighting) several times in any hour should be treated as being in NEC C, regardless of the  $L_{Aeq, 8 \text{ hour}}$  (except where the  $L_{Aeq, 8 \text{ hour}}$  already puts the site in NEC D.

<sup>(3)</sup> Aircraft noise: daytime values accord with the contour values adopted by the Department of Transport which relate to levels measured 1.2m above open ground. For the same amount of noise energy, contour values can be up to 2 dB(A) higher than those of other sources because of ground reflection effects.

<sup>(4)</sup> Mixed sources: this refers to any combination of road, rail, air and industrial noise sources. The "mixed source" values are based on the lowest numerical values of the single source limits in the table. The "mixed source" NECs should only be used where no individual noise source is dominant.

To check if any individual noise source is dominant (for the purposes of this assessment) the noise level from the individual sources should be determined and then combined by decibel additional (remembering first to subtract 2 dB(A) from any aircraft noise contour values). If the level of any one source then lies within 2 dB(A) of the calculated combined value, that source should be taken as the dominant one and the site assessed against the appropriate NEC for that source, rather than using the "mixed source" NECs. If the dominant source is industrial noise see paragraph B17 of Annex B (of TAN 11).

If the contribution of the individual noise sources to the overall noise level cannot be determined by measurement and/or calculation, then the overall measured level should be used and the site assessed against the NECs for "mixed sources".

Source: TAN 11, Annex A, Table 2

In relation to noise from industrial or fixed mechanical sources TAN 11 recommends the use of BS4142 as described in Section 2.5 below.

## 2.4 ProPG

Professional Practice Guidance on Planning and Noise (ProPG)<sup>4</sup> provides guidance which reflects the policy set out in National Planning Policy Framework (NPPF), Noise Planning Statement for England (NPSE) and Planning Practice Guidance - Noise (PPGN) specifically to be used for new residential developments.

ProPG encourages sustainable and better acoustic design for new residential developments and aims to protect people from the harmful effects of noise. The aims of ProPG are to:

*“advocate full consideration of the acoustic environment from the earliest possible stage of the development control process;  
encourage the process of good acoustic design in and around new residential developments;  
outline what should be taken into account in deciding planning applications for new noise-sensitive developments;  
improve understanding of how to determine the extent of potential noise impact and effect; and;  
assist the delivery of sustainable development.”*

While noise can override other planning concerns, neither the NPSE nor the NPPF expect noise to be considered in isolation from economic, social or other environmental dimensions of Scheme. Instead, the NPPF states that economic, social and environmental gains from the development should be sought jointly.

ProPG states that there are no specific noise levels at which noise becomes a material consideration or at which development is prohibited; instead, the decision to grant or refuse planning consent should take account of the acoustic environment and in doing so consider:

- whether or not a significant adverse effect is occurring or likely to occur
- whether or not an adverse effect is occurring or likely to occur
- whether or not a good standard of amenity can be achieved

This is consistent with the aims of the NPSE.

Two specific factors set out in PPGN, that influence whether noise could be a concern, are particularly relevant for residential development in areas subject to high levels of transportation noise. These are as follows:

- Consideration should *“be given to whether adverse internal effects can be completely removed by closing windows and, in the case of new residential developments, if the proposed mitigation relies on windows being kept closed most of the time. In both cases a suitable alternative means of ventilation is likely to be necessary”*
- *“If external amenity spaces are an intrinsic part of the overall design, the acoustic environment of those spaces should be considered so that they can be enjoyed as intended.”*

ProPG sets out a risk-based, sequential two-staged approach to address noise aspects of a Scheme. These stages are:

Stage 1 – an initial noise risk assessment of the Scheme site which should:

- provide an indication of the likely risk of adverse effects if no subsequent mitigation were to be included as part of the development plans; and
- indicate whether the proposed site is considered to pose a negligible, low, medium or high risk from a noise perspective

Stage 2 – a systematic consideration of four key elements which are:

- Element 1 – demonstrating a “Good Acoustic Design Process”
- Element 2 – observing internal “Noise Level Guidelines”
- Element 3 – undertaking an “External Amenity Area Noise Assessment”
- Element 4 – consideration of “Other Relevant Issues”

The Stage 1 Risk assessment process is outlined in Figure 2.1. It shows how noise levels are associated with an increased risk of adverse effect from noise and the pre-planning advice associated with noise levels. It should be noted that a noise risk assessment based on the daytime and night-time  $L_{Aeq}$  noise levels at a site does not form the basis of a recommendation for residential development and so this will only form part of the overall assessment.

**Figure 2.1: Stage 1 – Initial site noise risk assessment**

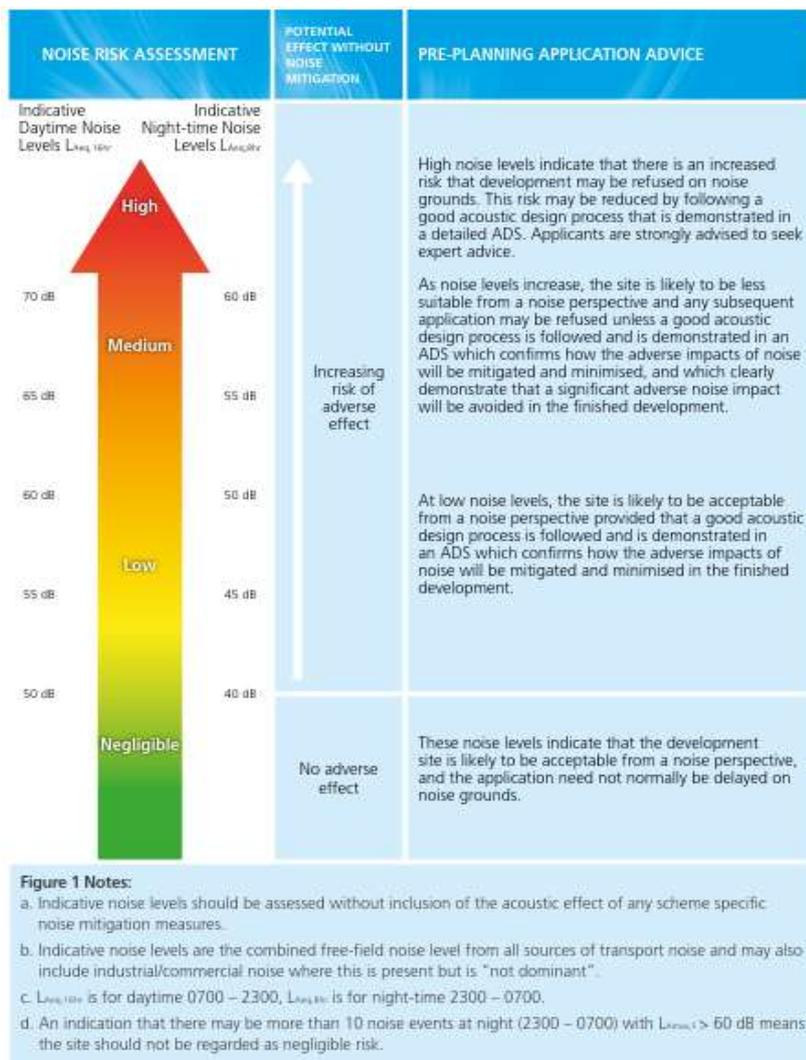

Source: ProPG

Section 5.0 of this report addresses the initial noise risk associated with this development based on ProPG Stage 1.

## 2.5 British Standard BS4142:2014+A1:2019

BS 4142 provides a method for assessing the impact of industrial noise sources on residential receivers. In this sense, industrial noise sources include mechanical plant associated with new buildings and developments.

The relevant parameters are as follows.

- Background Sound Level in  $L_{A90,T}$ ;
- Specific Sound Level, or Source Sound Level, in  $L_{Aeq,T}$ ; and
- Rating Level in  $L_{Aeq,T}$  which is the specific sound level plus any penalties given for the characteristic features of the sound.

The rating method detailed within the standard is widely accepted as an effective means of assessing the significance of building plant noise. The level of sound from proposed new plant (the overall rating level) is predicted in terms of  $L_{Aeq}$  and compared to the existing background sound level, in terms of  $L_{A90}$ . The  $L_{A90}$  is to be representative of the period being assessed. If the specific sound includes tonal, impulsive or other features likely to attract attention, assessed at the off-site noise sensitive receptors (e.g. residential), a character penalty, from 2 to 18 dB (although unlikely to exceed 10dB) is added to the specific sound level. Plant that contains these character features should therefore be avoided where practical.

The outcome of the assessment is defined in BS 4142 with the following points that relate to the difference between the background sound level and the rating level:

- Typically, the greater this difference, the greater the magnitude of the impact
- A difference of around +10dB or more is likely to be an indication of a significant adverse impact, depending on the context
- A difference of around +5dB is likely to be an indication of an adverse impact, depending on the context

The lower the rating level is relative to the measured background sound level, the less likely it is that the specific sound source will have an adverse impact or a significant adverse impact. Where the rating level does not exceed the background sound level, this is an indication of the specific sound source having a low impact, depending on the context.

## 2.6 British Standard BS 8233:2014

BS 8233 (2014) 'Guidance on sound insulation and noise reduction for buildings', provides guidance for the control of noise in and around new or refurbished buildings. Within the guidance, values for the internal ambient noise levels for different building uses are recommended. It states that it is 'desirable' that internal noise levels in dwellings do not exceed 35dB  $L_{Aeq,16hr}$  in living rooms and bedrooms during the day, 40dB  $L_{Aeq,16hr}$  in dining rooms during the day and 30dB  $L_{Aeq,8hr}$  in bedrooms at night. These values are often used to inform the level of sound insulation required in the walls, glazing and ventilation at the detailed design stage of the proposed residential developments.

BS 8233 provides some guidance on acceptable exterior noise levels within amenity spaces. It states: "For traditional external areas that are used for amenity space, such as gardens and patios, it is desirable that the external noise level does not exceed 50 dB  $L_{Aeq,T}$ , with an upper guideline value of 55 dB  $L_{Aeq,T}$  which would be acceptable in noisier environments. However, it is also recognized that these guideline values are not achievable in all circumstances where development might be desirable."

## 2.7 World Health Organization guidance

The World Health Organization (WHO) Guidelines for Community Noise and Night Noise Guidelines provides guidance on maximum noise levels within residential dwellings during night-time periods which can cause sleep disturbance. Guidance advises that internal noise levels should not exceed 45dB  $L_{Amax,f}$  (not to be exceeded 10 to 15 times a night) due to individual events.

The WHO Environmental Noise Guidelines for the European Region provides evidence-based recommendations on the health effects of noise. The guidelines complement the expert-based recommendations of the WHO 'Night Noise Guidelines' (2009) (NNG). Guidelines provide source specific recommendations for road traffic, railway, aircraft and wind turbine noise, and indoor as well as outdoor exposure levels for leisure noise.

## 2.8 British Standard BS 7445:2003

BS 7445:2003 '*Description and measurement of environmental noise*' sets out the basic requirements for the measurement of environmental noise on site and its processing and description using the various environmental noise parameters.

## 3 Survey methodology

### 3.1 Measurement procedure

A noise survey was undertaken in December 2023 and January 2024.

The survey comprised both unattended, continuous long-term (LT) measurement and attended, short-term measurements (ST). Automatic unattended monitoring was conducted from Saturday 09 December to Thursday 21 December 2023 and attended measurements were conducted on Friday 05 January 2024.

Measurement positions were selected to be representative of the noise climate across the site and at the nearest sensitive receptors potentially subject to operational noise as a result of the development.

All equipment used for baseline noise measurements complied with Class 1 requirements given in BS EN 61672<sup>1</sup>. The sound level meters were fitted with a microphone and windshield suitable for outdoor measurement. All measurements, Short term (ST) and Long Term (LT) measurements were taken at a height of between 1.2m and 1.5m above local ground. The long term (LT) measurement was located near the southern boundary of the site close to the residential property.

Unless otherwise stated, all ST measurement locations were 'free-field' meaning they are at least 3.5m from an acoustically reflective façade. Measurements were completed by a Mott MacDonald acoustician competent in environment noise monitoring and completed in accordance with the principles of BS 7445<sup>2</sup>.

The calibration level of all equipment was checked before and after the measurement periods and no significant changes were noted.

Equipment was configured to measure using the fast time weighting and A-frequency weighting in 15-minute intervals for both the LT and ST measurements.

Noise levels were measured in decibels for a range of stated descriptors that are defined below.

- $L_{Amax}$  – the highest value of the A-weighted sound pressure level with a specified time weighting that occurs during a given event.
- $L_{Aeq,T}$  – also referred to as the continuous equivalent noise level, it is the A-weighted sound pressure level that is the same amount of sound energy as the time varying noise over the same period of time (T).
- $L_{A10,T}$  – the A-weighted sound pressure level that is exceeded for 10% of a given time interval (T).
- $L_{A90,T}$  – also referred to as the background noise level, it is the A-weighted sound pressure level that is exceeded for 90% of a given time interval (T).

A-weighting – As seen in the parameters above, this is a frequency weighting designed to mimic the frequency response of the human ear by providing corrections for the frequencies which the human ear is less sensitive to.

---

<sup>1</sup> BS EN 61672-1:2013 'Electroacoustics-Sound level meters Part 1: Specifications.'

<sup>2</sup> British Standards Institution BS 7445 Description and measurement of environmental noise. Part 1: Guide to quantities and procedures, 2003,



### 3.2 Measurement locations

Measurement locations and details are provided in Figure 3.1 and Table 3.1.

Figure 3.1: Noise measurement locations

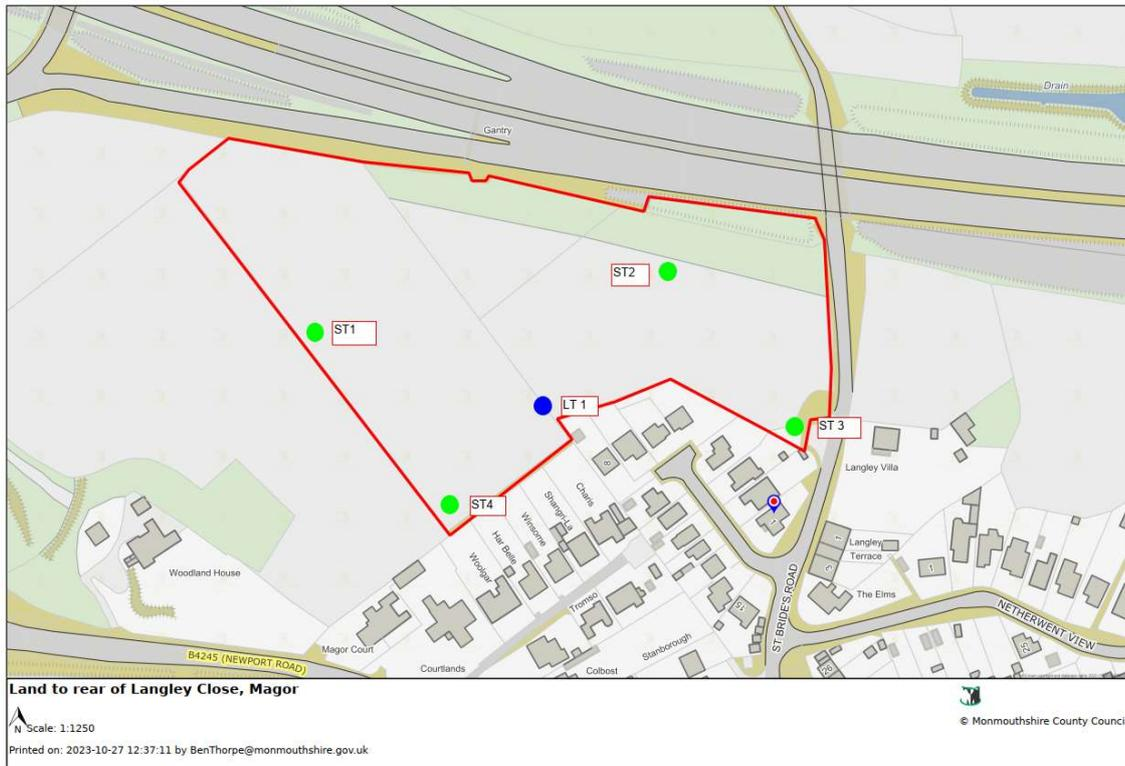

Source: Monmouthshire County Council with Mott MacDonald mark-up

Table 3.1: Noise measurement location details

Measurement ID	Measurement type	Microphone height from existing ground (m)
LT1	Free field	1.2m / 1.5m
ST1	Free field	1.2m
ST2	Free field	1.2m
ST3	Free field	1.2m
ST4	Free field	1.2m

Source: Mott MacDonald

### 3.3 Equipment

A full inventory of all equipment used during the baseline noise surveys is shown in Table 3.2

Table 3.2: Inventory of noise measurement equipment

Item	Model	Serial Number	Calibrated until
LT	Rion NL-52	898306	20-Sep-25
ST	Rion NL-52	1176426	04/05/2024
Calibrator	Rion NC75	34913591	21/02/2023

Source: Mott MacDonald

### 3.4 Weather conditions

The weather conditions during the attended survey (ST measurements and installation) were considered suitable for undertaking noise measurements.

Weather conditions were measured at LT1 during the survey and reported below.

During the automatic unattended noise survey there were periods when wind speeds exceeded 5m/s and periods which were subject to rain. These periods have been excluded during the processing of the measured noise data.

Table 3.3 presents details of the weather conditions.

**Table 3.3: Weather summary**

Date	Average Temp (Degrees C)	Average Wind Speed (m/s)	Average Rainfall (mm)
09/12/2023			
10/12/2023	10.1	1.5	0.0
11/12/2023	10.2	1.5	0.1
12/12/2023	9.7	0.6	0.0
13/12/2023	9.4	0.4	0.1
14/12/2023	6.6	0.5	0.0
15/12/2023	6.3	0.1	0.0
16/12/2023	6.9	0.3	0.0
17/12/2023	9.9	1.2	0.0
18/12/2023	9.9	1.4	0.0
19/12/2023	10.6	1.3	0.4
20/12/2023	9.0	0.6	0.3
21/12/2023	9.5	0.8	0.0

Source: Mott MacDonald

### 3.5 Limitations

Inevitably there is a degree of variation in measured noise levels. Contributory factors to this variation include tolerances in instrumentation readings, meteorological conditions, and the inherent difference in the acoustic environment during the course of the day and indeed over longer periods as the noise sources influencing a given location vary. Every effort has been made to limit variation in the measurements reported. The following efforts have been made in order to reduce measurement uncertainty.

- Undertaking surveys with appropriately qualified and trained acoustic engineers
- Use of measurement equipment calibrated to appropriate standards by accredited bodies and checked on site using calibrated reference sound sources
- Following best practice methodology for environmental noise measurement set out in BS 7445
- Measuring under appropriate meteorological conditions
- Measuring at times and locations that are representative of the noise climate at any particular location
- Analysing the data to notice trends and anomalies, ensuring the data is representative for the location

## 4 Measurement results

This section presents the full data results for both Long-Term (LT) and Short-term (ST) noise measurements.

For the purposes of the assessment, only the  $L_{Aeq}$  and  $L_{A90}$  parameters are presented for the LT measurements and  $L_{Aeq}$  for the ST measurements.

LT  $L_{Aeq}$  noise measurements are shown for daytime (07:00 to 23:00), and night-time (23:00 to 07:00) in accordance with guidance provided by TAN 11 and BS 4142.

LT  $L_{A90}$  noise measurements have been analysed to determine a single number value which is considered to be the representative background noise level during the relevant assessment periods in accordance with guidance provided by BS 4142. In this case the lowest 10<sup>th</sup> percentile value of the  $L_{A90,15min}$  values has been used.

### 4.1 Long term

Position LT1 was located near to a field boundary close to the southern edge of the field next to a residential property on Langley Close. It was installed at 09:40 on 09 December 2023 and collected at 11:10 on 21 December 2023.

The major noise source was road traffic noise from the M4 motorway and off ramps to the Magor Interchange.

The levels relevant to the assessment are summarised in Table 4.1 below. Figure 4.1 shows the time history of the measurement.

Partial measurement periods at the start and end of the survey have been included.

**Table 4.1: LT1 measurement results (free-field measurement)**

Date	Average $L_{Aeq, T}$ dB		$L_{A90, T}$ dB	
	Day (07:00-23:00)	Night (23:00-07:00)	Day (07:00-23:00)	Night (23:00-07:00)
9 December 2023	61.3	53.3	55.8	47.3
10 December 2023	60.5	57.7	53.2	49.7
11 December 2023	59.9	56.2	52.5	46.3
12 December 2023	60.1	58.1	54.3	49.1
13 December 2023	62.9	56.2	56.0	49.7
14 December 2023	59.6	57.7	54.1	52.3
15 December 2023	58.8	53.2	53.3	46.8
16 December 2023	57.8	50.9	51.5	43.4
17 December 2023	57.0	53.1	51.1	44.4
18 December 2023	58.6	57.2	54.1	49.4
19 December 2023	62.2	55.8	55.1	48.0
20 December 2023	59.4	56.2	52.7	49.4
21 December 2023	62.1		59.1	
<b>Baseline level for assessment</b>	<b>60.0</b>	<b>55.5</b>	<b>54.1</b>	<b>48.0</b>

**Figure 4.1: LT1 plot of results of the long term noise monitoring**

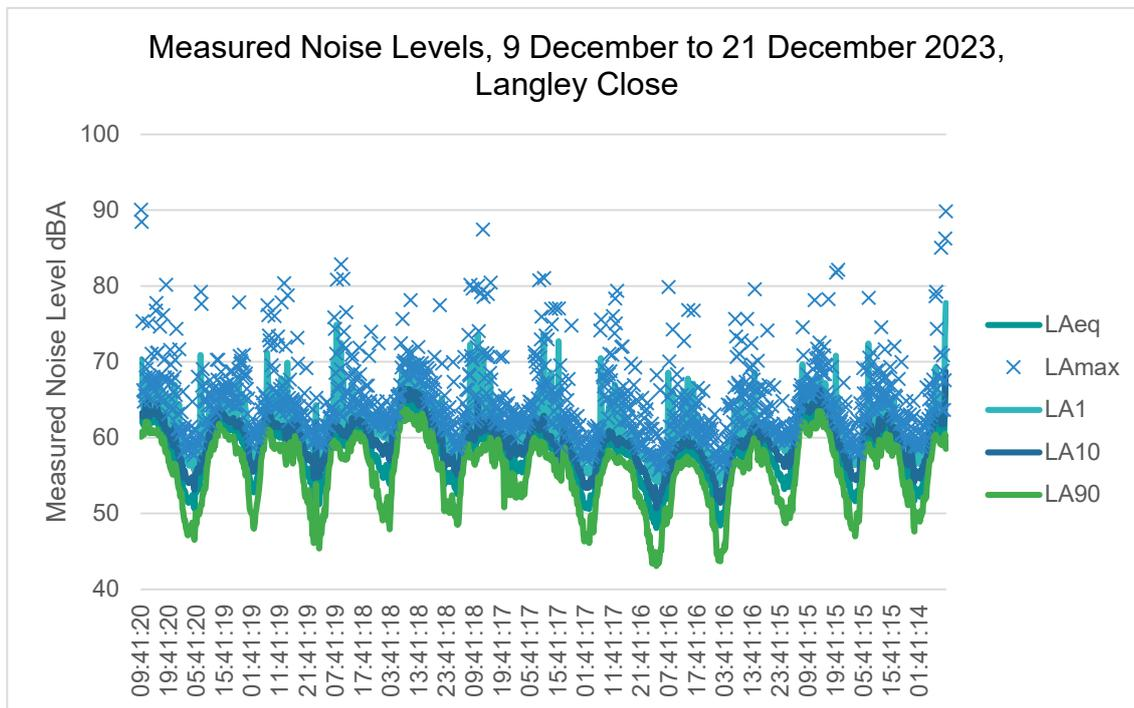

**4.2 Short term**

The noise climate of the short term monitoring positions was dominated by road traffic noise from the M4 motorway and offramps to the Magor Interchange.

In order to determine the geographical variation in noise level across the site relative to the measured noise levels at LT1 an automatic unattended noise logger was set up at LT1 during the attended measurements. This was set up such that 5-minute samples at the ST locations

were synchronous with the 5 minute samples at LT1. The difference between the measured  $L_{Aeq,5 \text{ minute}}$  samples were then used to calculate an estimate of the  $L_{Aeq, 16hr}$  and  $L_{Aeq, 8hr}$  at the ST locations. This comparison is shown in Appendix C.

The supplementary ST noise levels and comments on the main noise sources are summarised in Table 4.2 below.

**Table 4.2: Summary of ST measurements (5 minutes for each measurement)**

ST	Date	Start time	$L_{Aeq, T}$ dB	$L_{Amax, T}$ dB	$L_{A10, T}$ dB	$L_{A90, T}$ dB	Main noise source and comments
NE		08:35	66	70.1	67.7	63.1	M4 and Off ramp,
NE		08:40	65.4	69.4	67.3	62.9	M4 and Off ramp,
NE		09:30	64.1	68.6	65.8	61.8	M4 and Off ramp,
NE		09:35	64.2	68.5	66.2	61.7	M4 and Off ramp,
NW		08:55	61.4	64.2	62.6	59.8	M4 and Off ramp,
NW		09:00	61.1	64.5	62.3	59.5	M4 and Off ramp,
NW		09:45	58.1	62.3	59.2	56.8	M4 and Off ramp,
NW		09:50	57.2	61.1	58.6	55.3	M4 and Off ramp,
SW		09:00	57.8	60.8	58.9	56.7	M4 and Off ramp,
SW		09:05	58.5	61.2	59.4	57.5	M4 and Off ramp,
SW		09:55	54.3	60.1	55.6	52.4	M4 and Off ramp,
SW		10:00	53.5	56.4	54.8	52.0	M4 and Off ramp,
SE		09:15	62.1	65.3	63.3	60.4	M4 and Off ramp,
SE		09:20	61.4	64	62.5	60.2	M4 and Off ramp,
SE		10:10	60.5	63.1	61.7	59.1	M4 and Off ramp,
SE		10:15	60.5	64.7	62.0	58.5	M4 and Off ramp,

## 5 Assessment

### 5.1 TAN 11

The measured  $L_{Aeq,16hr}$  and  $L_{Aeq,8hr}$  values at each of the measurement locations have been used to determine which areas of the site are within the NEC Categories shown in Table 2.3. These areas have been drawn in Figure 5.1 below:

Figure 5.1: Areas within TAN 11 NEC Categories

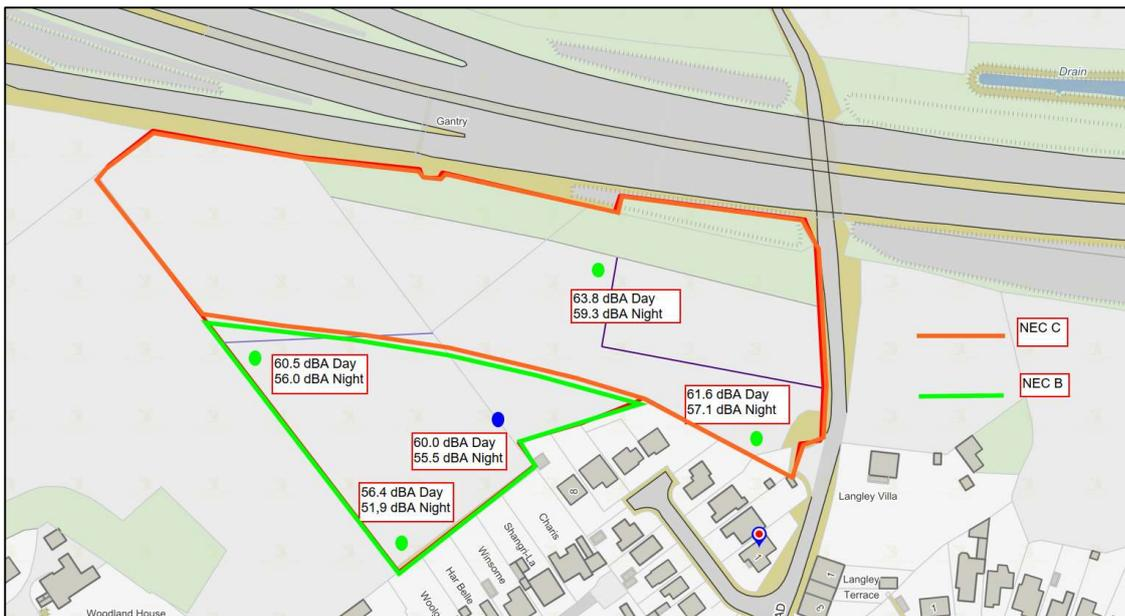

Source: Mott MacDonald

It can be seen that the majority of the site would fall within NEC C for which *'Planning permission should not normally be granted. Where it is considered that permission should be given, for example, because there are no alternative quieter sites available, conditions should be imposed to ensure a commensurate level of protection against noise.'*

The southern part of the site however falls within NEC B for which *'Noise should be taken into account when determining planning applications and, where appropriate, conditions imposed to ensure an adequate level of protection.'*

### 5.2 ProPG

Measured  $L_{Aeq}$  Levels on site at LT1, approximately 150m from the M4 offramp were  $60dBL_{Aeq,16hr}$  during daytime and  $55.5dBL_{Aeq,8hr}$  at night. Comparing these levels with the chart shown in Figure 1 indicates that the ProPG Stage 1 Risk assessment methodology would assign a *'Medium'* risk during daytime and night.

Calculated  $L_{eq,16hour}$  levels up to 63.8 dB and up to 59.3dB at the short-term measurement location closest to the M4 motorway. This monitoring locations was approximately 32m from the edge of the M4 motorway off ramp. Comparing these levels with the chart shown in Figure 2.1 indicates that the ProPG Stage 1 Risk assessment methodology would assign a *'Medium'* risk during daytime and *"high"* risk at night due to noise at this part of the site.

ProPG is generally aimed at developments comprising substantial bricks and mortar buildings or other relatively massive constructions. The Gypsy and Traveller site would however accommodate mobile homes. These have lower sound insulation values than more substantial homes and this needs to be taken into account.

BS 8233 states that it is 'desirable' that internal noise levels in dwellings do not exceed 35dB  $L_{Aeq,16hr}$  in living rooms and bedrooms during the day, 40dB  $L_{Aeq,16hr}$  in dining rooms during the day and 30dB  $L_{Aeq,8hr}$  in bedrooms at night. It is estimated that a mobile home may provide a sound insulation value of around 15dB to 20dB with windows closed.

Based on the measured noise levels at LT1 at 105m from the M4, internal levels would be estimated to be around 45dB  $L_{Aeq,16hr}$  during daytime and 40dB  $L_{Aeq,8hr}$  at night. These are above the internal noise level recommendations provided by BS 8233.

The calculated  $L_{Aeq,16hr}$  at the northern end of the site was 63.8dB during daytime and the  $L_{Aeq,8hr}$  at night was 59.3dB. Internal noise levels with a mobile home would therefore be up to 49dB at this location during daytime and 44dB at night. These levels exceed the internal recommendations of BS 8233.

Achieving the internal noise levels within mobile homes recommended by BS 8233 by distance attenuation alone would not be feasible. At the most southerly of monitoring locations the calculated  $L_{Aeq,16hr}$  levels are up to 56.4dB and up to 51.9dB. At this location internal levels would be estimated to be around 41dB  $L_{Aeq,16hr}$  during daytime and 37dB  $L_{Aeq,8hr}$  at night. These levels still exceed the internal noise level recommendations of BS 8233 even though this location is farthest from the M4 motorway.

It may be possible to construct a noise barrier or earth bund along the northern boundary of the site which would significantly attenuate noise levels from the M4. This barrier would however need to be of a considerable height to achieve the required level of noise attenuation at the eastern end of the site and would probably need to return southward along the eastern boundary of the site.

It is therefore considered that the southern part of the site may possibly be suitable for development as a Gypsy and Traveler Site provided mitigation measures are implemented. However, the mitigation required would need to comprise noise barriers/bunds which would be of significant height particularly at the eastern end of the site.

### 5.3 BS 4142

There are not expected to be any major noise sources associated with the Gypsy and Traveller site, but minor plant such as toilet extract fans, generators and air conditioning units etc may potentially be expected.

Background  $L_{A90}$  sound levels of 54.0dB during daytime and 48.1dB during night-time were measured on site. BS 4142 state that "*where the rating level does not exceed the background sound level, this is an indication of the specific sound source having a low impact, depending on the context*" and the background noise level is often used as a noise limit for noise emissions from new developments.

It is therefore recommended that noise levels created by any plant associated with the proposed Gypsy and Traveller site should be limited to 54dB  $L_{Aeq,1hr}$  during daytime and 48dB  $L_{Aeq,15min}$  at night at the nearest potentially affected residences.

## 5.4 BS 8233

BS 8233 also provides some guidance on acceptable exterior noise levels within amenity spaces. It states: *“it is desirable that the external noise level does not exceed 50 dB  $L_{Aeq,T}$ , with an upper guideline value of 55 dB  $L_{Aeq,T}$  which would be acceptable in noisier environments.”*

The measured noise levels at LT1, and ST1 to ST4 all exceeded with 50dB  $L_{Aeq,T}$ .

It would therefore be advisable to provide localised noise screening for the outdoor amenity areas within the site. This may take the form of solid noise barriers or landscaped bunds between the M4 motorway and the residential plots of the site as described above for control of internal noise levels within mobile homes.



## 6 Conclusions

This report documents the findings of the baseline noise monitoring and assessment undertaken for the proposed Gypsy and Traveller site at Langley Close.

Measured noise levels have been used to assess the risk of noise having an adverse impact upon the site in accordance with the ProPg Stage 1 Risk Assessment method. This assessment shows there is a 'high' risk of noise adversely impacting the northern part of the site. The rest of the site would be subject to a 'medium' risk of noise adversely impacting the site.

However, the above guidance is intended primarily to deal with dwellings which are constructed from bricks and mortar. Mobile homes provide significantly lower levels of sound attenuation between exterior and interior. It is estimated that a mobile home may provide a sound insulation value of around 15dB to 20dB with windows closed.

Based on the levels of noise measured on the site interior noise levels would exceed the recommended noise levels given in BS 8233 across the whole site. However, if an earth bund or solid noise barrier were constructed along the northern edge of the site this may provide sufficient sound attenuation that the internal noise criteria recommended by BS 8233 would be met within mobile homes on the southern part of the site. This barrier/ bund would however need to be of significant height and may need to extend down the eastern boundary of the site. This is likely present significant technical issues in attempting to achieve satisfactory internal noise levels within mobile homes.

In setting noise criteria for mechanical plant associated with the site it may be more appropriate to set criteria in terms of absolute levels taken from BS 8233:2014 *Guidance on sound insulation and noise reduction for buildings* or Night noise guidelines for Europe 2009 rather than relative levels in terms of BS 4142:2014+A1:2019 *Methods for rating and assessing industrial and commercial sound*.

Noise level limits of 54dB  $L_{Aeq,1hr}$  during daytime and 48dB  $L_{Aeq,15min}$  at night proposed for fixed plant noise emissions from the site.

Measured noise levels at all locations on the site exceeded the 50dB  $L_{Aeq,T}$  value recommended by BS 8233 for external amenity areas. It would therefore also be necessary to provide localised noise screening for the outdoor amenity areas. This may take the form of solid noise barriers or landscaped bunds between the M4 and the residential plots of the site. This barrier would need to be of significant height in order to achieve the desired exterior level of 50 dB  $L_{Aeq,T}$  especially at the eastern end of the site.

If planning permission is granted, a Stage 2 Acoustic Assessment should be conducted in which the landscape design of the proposed site should be developed to incorporate acoustic screening for the plots closest to the north-eastern corner.

## A. Acoustic Glossary

<b>A-weighting</b>	The human ear also has a non-linear frequency response, being most sensitive in the frequency range 1 kHz to 4 kHz and is less sensitive at higher and lower frequencies. The A-weighting is a frequency function commonly applied to the linear output of a microphone to simulate the subjective response of the ear. A-weighted levels are usually indicated by a subscript A or postscript (A).
<b>Z-weighting</b>	A flat frequency response between 10Hz and 20kHz excluding microphone response.
<b>Decibel</b>	Sound and noise are commonly described using the decibel (dB) scale, which is logarithmic in nature to relate to the response of the human ear. The range of human hearing commonly varies from the threshold of audibility (0dB) to the threshold of pain (120dB). Such limits are seldom experienced in practice and typical levels might vary between 30dB in a quiet bedroom at night to 90dB at the kerbside of a busy road.
<b>Sound Pressure Level (Lp)</b>	The logarithmic measure of the root mean square sound pressure relative to a reference sound pressure. The reference sound pressure in air is 20 micro Pascals and represents the threshold of hearing in a healthy young person.
<b>Equivalent continuous noise level Leq</b>	The equivalent continuous noise level, $L_{Aeq,T}$ , is the notional level of a steady sound which, at a given position and over the same period of time (T), would deliver the same sound energy as the fluctuating one. Used to quantify time-varying noise from industrial sources.
<b>Maximum sound pressure level L(max)</b>	The lowest sound pressure level reached within the measurement period.
<b>Minimum sound pressure level L(min)</b>	The lowest sound level reached within the measurement period.
<b>Ln</b>	A statistical parameter where the sound pressure level exceeded for a 'n' percentage of the measurement period.
<b>Fast weighting</b>	The sound pressure level is weighted to the response time of the ear (125ms).
<b>Slow weighting</b>	The sound pressure level is weighted to the response time of 1 second.

## B Comparison between 5 minute sample measurements at ST and LT locations

ST						LT1					
	Time	LAeq	LAmaz	LA10	LA90	Difference LAeq	Time	LAeq	LAmaz	LA10	LA90
NE	08:35	66	70.1	67.7	63.1	3.6	08:35	62.4	65.3	63.6	60.6
NE	08:40	65.4	69.4	67.3	62.9	2.9	08:40	62.5	65.5	63.7	61.1
NE	09:30	64.1	68.6	65.8	61.8	4.2	09:30	59.9	62.5	61.1	58.5
NE	09:35	64.2	68.5	66.2	61.7	4.3	09:35	59.9	62.5	61.1	58.5
						3.75					
	Time	LAeq	LAmaz	LA10	LA90	Difference LAeq	Time	LAeq	LAmaz	LA10	LA90
NW	08:55	61.4	64.2	62.6	59.8	0.1	08:55	61.3	64.6	62.5	59.7
NW	09:00	61.1	64.5	62.3	59.5	0.9	09:00	60.2	63.2	61.5	58.7
NW	09:45	58.1	62.3	59.2	56.8	-1.2	09:45	59.3	63.5	60.4	57.6
NW	09:50	57.2	61.1	58.6	55.3	-1.3	09:50	58.5	62.3	59.8	56.9
						0.5					
	Time	LAeq	LAmaz	LA10	LA90	Difference LAeq	Time	LAeq	LAmaz	LA10	LA90
SW	09:00	57.8	60.8	58.9	56.7	-2.4	09:00	60.2	63.2	61.5	58.7
SW	09:05	58.5	61.2	59.4	57.5	-2.5	09:05	61	64.5	62.2	59.8
SW	09:55	54.3	60.1	55.6	52.4	-4.5	09:55	58.8	61.7	60.2	56.7
SW	10:00	53.5	56.4	54.8	52	-5	10:00	58.5	62.4	60.2	56.5
						-3.6					
	Time	LAeq	LAmaz	LA10	LA90	Difference LAeq	Time	LAeq	LAmaz	LA10	LA90
SE	09:15	62.1	65.3	63.3	60.4	1.6	09:15	60.5	63.7	61.8	58.9
SE	09:20	61.4	64	62.5	60.2	1.6	09:20	59.8	64.3	61	58.3
SE	10:10	60.5	63.1	61.7	59.1	1.5	10:10	59	62.5	60.4	57.2
SE	10:15	60.5	64.7	62	58.5	1.5	10:15	59	62.2	60.4	57.3
						1.55					

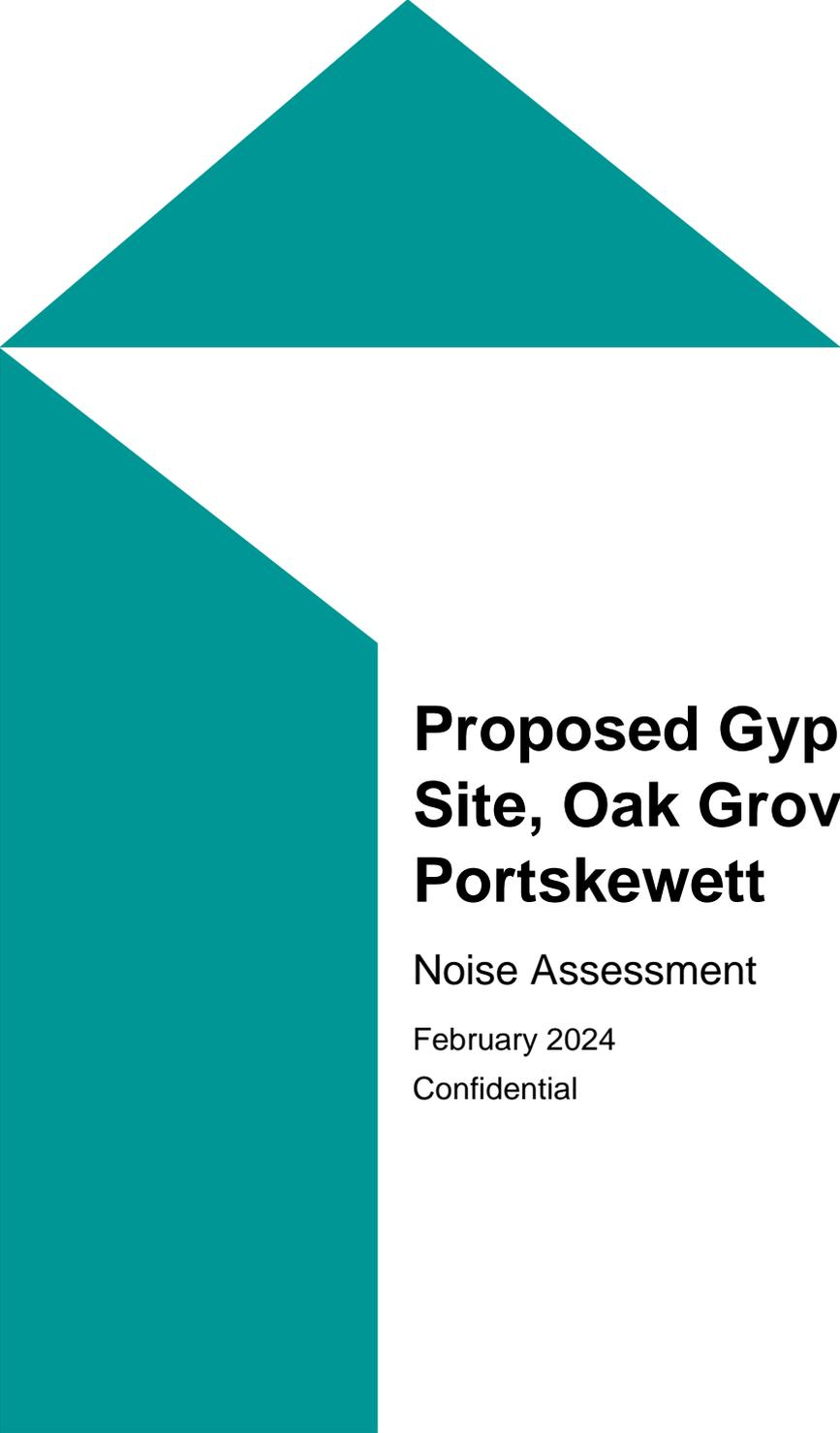

A large teal graphic on the left side of the page, consisting of a triangle at the top and a trapezoid below it, forming a shape that resembles a stylized roof or a large letter 'M'.

# **Proposed Gypsy and Traveller Site, Oak Grove Farm, Portskewett**

Noise Assessment

February 2024

Confidential

This page left intentionally blank for pagination.

Mott MacDonald  
10 Temple Back  
Bristol BS1 6FL  
United Kingdom

T +44 (0)117 906 9500  
mottmac.com

# **Proposed Gypsy and Traveller Site, Oak Grove Farm, Portskewett**

Noise Assessment

February 2024

Confidential

# Issue and Revision Record

Revision	Date	Originator	Checker	Approver	Description
0	09/02/24	R Roper	A Monk-Steel	R Perkins	First draft for client comment
1	18/04/24	R Roper	A Monk-Steel	R Perkins	Client comment addressed

**Document reference:** 100115516 | NS003 | P01 | 100115516

**Information class:** Standard

This document is issued for the party which commissioned it and for specific purposes connected with the above-captioned project only. It should not be relied upon by any other party or used for any other purpose.

We accept no responsibility for the consequences of this document being relied upon by any other party, or being used for any other purpose, or containing any error or omission which is due to an error or omission in data supplied to us by other parties.

This document contains confidential information and proprietary intellectual property. It should not be shown to other parties without consent from us and from the party which commissioned it.



# Contents

<b>1</b>	<b>Introduction</b>	<b>1</b>
1.1	Project description	1
1.2	Site description	1
1.3	Scope of the assessment	2
<b>2</b>	<b>Guidance and legislation</b>	<b>4</b>
2.1	Planning Policy Wales	4
2.2	Local authority policy and guidance	5
2.3	TAN 11	6
2.4	ProPG	8
2.5	British Standard BS 4142:2014+A1:2019	10
2.6	British Standard BS 8233:2014	10
2.7	World Health Organization guidance	11
2.8	British Standard BS 7445:2003	11
<b>3</b>	<b>Survey methodology</b>	<b>12</b>
3.1	Measurement procedure	12
3.2	Measurement locations	13
3.3	Equipment	13
3.4	Weather conditions	14
3.5	Limitations	14
<b>4</b>	<b>Measurement results</b>	<b>15</b>
4.1	Long term	15
4.2	Short term	16
<b>5</b>	<b>Assessment</b>	<b>18</b>
5.1	TAN 11	18
5.2	ProPG	18
5.3	BS 4142	19
5.4	BS 8233	19
5.5	World Health Organization guidance	20
<b>6</b>	<b>Conclusions</b>	<b>21</b>
<b>A.</b>	<b>Acoustic Glossary</b>	<b>23</b>

## B Comparison between 5 minute sample measurements at ST and LT locations 24

### Tables

Table 3.1: Noise measurement location details	13
Table 3.2: Inventory of noise measurement equipment	13
Table 3.3: Weather summary	14
Table 4.1: LT1 measurement results (free-field measurement)	16
Table 4.2: Summary of ST measurements (5 minutes for each measurement)	17

### Figures

Figure 1.1: Proposed site layout	2
Figure 2.1: Stage 1 – Initial site noise risk assessment	9
Figure 3.1: Noise measurement locations	13
Figure 4.1: LT1 plot of results of the long term noise monitoring	16
Figure 5.1: Areas within Tan 11 NEC Categories	18

# 1 Introduction

## 1.1 Project description

Monmouthshire County Council (MCC) has a legal and moral duty to ensure everyone has access to good quality homes. MCC recognises that safe, culturally-appropriate accommodation is necessary for individuals to flourish in other parts of their lives. In accordance with the Housing (Wales) Act, 2014, MCC has identified a need for additional sites to house the Gypsy and Traveller families already living in Monmouthshire.

Three Council owned sites in Monmouthshire have been identified as potentially suitable to meet the current needs for the Gypsy and Traveller community. Mott MacDonald was commissioned by MCC to conduct noise surveys and assessments at proposed development sites in Monmouthshire at:

- Langley Close, Magor,
- Land at Bradbury Farm, Crick; and
- Land at Oak Grove Farm, Portskewett.

It is proposed to develop one of these sites as a Gypsy and Travellers site.

Mott MacDonald has been appointed by MCC to provide a noise assessment report as part of MCC's Gypsy and Traveller Accommodation Assessment (GTAA) identification study for the Oak Grove Farm, Portskewett, Monmouthshire (hereafter referred to as "**the proposed Gypsy and Traveller site**" or simply "the site"), one of the three council-owned identified sites for potential development. The proposed Gypsy and Travellers site is understood to comprise the construction of up to six pitches that will include parking and a collective utility block with access gained via the B4245 road which runs along the southern boundary of the site.

This report describes the noise impact assessment for the proposed development at Oak Grove Farm, Portskewett and assesses the potential impact on the development due to existing noise levels and sets criteria for any noise emissions from the site.

## 1.2 Site description

The site is currently agricultural fields on the north side of the B5245 road. The A48 road lies 130m north of northern boundary of the site and is separated from it by further agricultural land. The land to the east is arable and to the west is grazing. The site slopes gently downwards towards the north.

The noise environment at the southern end of the site is dominated by road traffic on the B4245 road whilst the northern end of the site is dominated by road traffic noise from the B4245 road and also the A48 road.

The site layout is shown in Figure 1.1.

Figure 1.1: Proposed site layout



Source: Monmouthshire County Council

### 1.3 Scope of the assessment

The purpose of the survey was to quantify the ambient noise levels impacting the site and the background sound levels at the nearby noise sensitive receptors (NSRs).

The suitability of the proposed sites is considered using Technical Advice Note, TAN 11: Noise (1997), Professional Practice Guidance on Planning and Noise (ProPG) with due consideration to the Noise and Soundscape Plan for Wales 2023-2028 and 'Supporting Document 1: Soundscape Design' (2022).

Noise levels due to existing noise sources potentially impacting the proposal are assessed in terms of the implications for the internal noise levels within a typical mobile home. As the type and construction of these mobile homes will vary this will be indicative only. Any mitigation measure proposed will be aimed at the layout and landscaping of the site as the design of mobile homes is clearly beyond the control of the designers.

Environmental noise limits for any proposed new plant associated with the development, would be set in accordance with the guidance in British Standard (BS) 4142 (2014+A1:2019) 'Methods for rating and assessing industrial and commercial sound', in the context of the TAN 11, Planning Policy Wales and any specific local authority requirements.

This report details the monitoring methodology, noise assessment methodology and any assumptions and limitations associated with the monitoring, and documents the results of the baseline monitoring. It appraises the potential impact of existing noise levels, using TAN 11 and the ProPG assessment methodology, on the proposed development and sets criteria for potential noise emissions from the site.

The baseline monitoring data has been processed in accordance with the requirements of the BS 4142 assessment method in order to set criteria for noise emissions from any mechanical plant such as toilet extracts, generators, air-conditioning units etc associated with the proposed development.

The baseline monitoring data has also been processed in accordance with BS 7445 (2003) '*Description and measurement of environmental noise*', British Standard BS 8233 (2014) '*Guidance on sound insulation and noise reduction for buildings*'.

## 2 Guidance and legislation

### 2.1 Planning Policy Wales

Planning Policy Wales (PPW) points out some similarities between air quality and noise in the way they impact a proposed site. Noise is not just considered in terms of its level. PPW also discusses the 'soundscape'. Selected sections of Planning Policy Wales, Edition 11 | February 2021 are reproduced below:

#### **Air Quality and Soundscape**

*6.7.1 Clean air and an appropriate soundscape, contribute to a positive experience of place as well as being necessary for public health, amenity and well-being. They are indicators of local environmental quality and integral qualities of place which should be protected through preventative or proactive action through the planning system. Conversely, air, noise and light pollution can have negative effects on people, biodiversity and the resilience of ecosystems and should be reduced as far as possible.*

*6.7.3 Certain sounds, such as those created by trees, birds or water features, can contribute to a sense of tranquillity whilst others can be reassuring as a consequence of their association with the normality of everyday activities. Problematic forms of sound are generally experienced as noise pollution and can affect amenity and be prejudicial to health or a nuisance.*

*6.7.4 The planning system should maximise its contribution to achieving the well-being goals, and in particular a healthier Wales, by aiming to reduce average population exposure to air and noise pollution alongside action to tackle high pollution hotspots. In doing so, it should consider the long-term effects of current and predicted levels of air and noise pollution on individuals, society and the environment and identify and pursue any opportunities to reduce, or at least, minimise population exposure to air and noise pollution, and improve soundscapes, where it is practical and feasible to do so.*

*6.7.5 In taking forward these broad objectives the key planning policy principle is to consider the effects which proposed developments may have on air or soundscape quality and the effects which existing air or soundscape quality may have on proposed developments. Air Quality and soundscape influence choice of location and distribution of development and it will be important to consider the relationship of proposed development to existing development and its surrounding area and its potential to exacerbate or create poor air quality or inappropriate soundscapes. The agent of change principle says that a business or person responsible for introducing a change is responsible for managing that change. In practice, for example, this means a developer would have to ensure that solutions to address air quality or noise from nearby pre-existing infrastructure, businesses or venues can be found and implemented as part of ensuring development is acceptable.*

*6.7.6 In proposing new development, planning authorities and developers must, therefore:*

- *address any implication arising as a result of its association with, or location within, air quality management areas, noise action planning priority areas or areas where there are sensitive receptors*
- *not create areas of poor air quality or inappropriate soundscape; and*
- *seek to incorporate measures which reduce overall exposure to air and noise pollution and create appropriate soundscapes.*

To assist decision making it will be important that the most appropriate level of information is provided and it may be necessary for a technical air quality and noise assessment to be undertaken by a suitably qualified and competent person on behalf of the developer.

6.7.8 Good design, for example setting back buildings from roads to avoid canyon effects and using best practice in terms of acoustic design to ensure the appropriate and intended acoustic environment of completed developments should be incorporated at an early consideration in the design and planning process.

## 2.2 Local authority policy and guidance

Oak Grove Farm falls under the ‘Monmouthshire County Council Adopted Local Development Plan 2011-2021’ which was adopted 27 February 2014 and sets out the plans, visions and policies for development.

6.3.60 Policy EP1 seeks to prevent development proposals that would result in unacceptable risk or harm due to air, light, noise or water pollution, contamination or land instability.

### EP1 - Amenity and Environmental Protection

Development, including proposals for new buildings, extensions to existing buildings and advertisements, should have regard to the privacy, amenity and health of occupiers of neighbouring properties. Development proposals that would cause or result in an unacceptable risk /harm to local amenity, health, the character /quality of the countryside or interests of nature conservation, landscape or built heritage importance due to the following will not be permitted, unless it can be demonstrated that measures can be taken to overcome any significant risk:

- .....
- Noise pollution;

.....

The Replacement Local Development Plan (RLDP) (2018 to 2033) includes the ‘Replacement Local Development Plan Sustainability Appraisal Scoping Report Appendix 1 – Review of Plans, Policies, Programmes and Strategies November 2022, in which Monmouthshire Council includes the following section of table:

**Table 2.1 Selected Section of Table Sustainability Appraisal Scoping Report Appendix 1 – Review of Plans, Policies, Programmes and Strategies**

ISA Theme: Health & Well-being	
International, European, National (UK), National Wales	
Planning Policy Wales Edition 11 (2021) Technical Advice Note (TAN) 11: Noise (1997) (Revised TAN currently being consulted on by WG) Technical Advice Note (TAN) 16: Sport, recreation and open space (2009)	<i>Planning Policy Wales (PPW) sets out the land use planning policies of the Welsh Government. It is supplemented by a series of Technical Advice Notes. It translates our commitment to sustainable development into the planning system so that it can play an appropriate role in moving towards sustainability. Planning Policy Wales (PPW) puts a commitment to achieving the Well-being goals of the Well-being of Future Generations Act at the centre of the planning system in Wales. PPW notes that planning</i>

---

*authorities have a role to play in the prevention of physical and mental illnesses caused by pollution, isolation from society and activities, and must consider the impact of new development on communities and prioritise health protection. It requires planning authorities to:*

- Contribute to the protection and, where possible, the improvement of people's health and wellbeing as a core component of achieving the well-being goals and responding to climate change.*
  - Consider the possible impacts of developments – positive and/or negative – on people's health at an early stage will help to clarify the relevance of health and the extent to which it needs to be considered.*
  - Ensure, as far as is practicable, that noise-sensitive developments, such as hospitals, schools, and housing, that need to be located close to the existing transportation infrastructure to facilitate access, are designed in such a way as to limit noise levels within and around those developments.*
  - Consider national air quality objectives, recognising that they represent a pragmatic threshold above which government considers the health risks associated with air pollution are unacceptable.*
- 

## 2.3 TAN 11

Planning Policy Wales is supplemented by a series Technical Advice Notes (TAN) that provide detailed planning advice on different subjects. TAN 11: Noise (1997) provides a methodology for assessing the suitability of a site for residential development near existing sources of noise. It provides threshold noise levels for Noise Exposure Categories (NECs), which determine the suitability of the site for residential development and within which various levels of consideration to mitigation should be given. These noise exposure categories are provided for road, rail, aircraft and mixed sources. Separate noise level ranges are specified for the day-time and night-time periods for each of the NECs. The degree of consideration required for each Noise Exposure Category is described in Table 2.2 below.



**Table 2.2: Noise exposure categories for dwellings**

Noise Exposure Categories	
A	Noise need not be considered as a determining factor in granting planning permission, although the noise level at the high end of the category should not be regarded as desirable.
B	Noise should be taken into account when determining planning applications and, where appropriate, conditions imposed to ensure an adequate level of protection.
C	Planning permission should not normally be granted. Where it is considered that permission should be given, for example, because there are no alternative quieter sites available, conditions should be imposed to ensure a commensurate level of protection against noise.
D	Planning permission should normally be refused.

Source: TAN11, Annex A, Table 1

The noise level ranges of the various categories are shown in Table 2.3 below.

**Noise Table 2.3: Recommended Noise Exposure Categories (NEC) for new dwellings near existing noise sources**

Noise levels <sup>(1)</sup> corresponding to noise exposure categories in $L_{Aeq, T}$ dB		Noise exposure category			
Noise source	Time period	A	B	C	D
Road traffic	Day time 07:00 to 23:00	< 55	55-63	63-71	> 72
	Night time 23:00 to 07:00 <sup>(2)</sup>	< 45	45-57	57-66	> 66
Rail traffic	Day time 07:00 to 23:00	< 55	55-66	66-74	> 74
	Night time 23:00 to 07:00 <sup>(2)</sup>	< 45	45-59	59-66	> 66
Air traffic <sup>(3)</sup>	Day time 07:00 to 23:00	< 57	57-66	66-72	> 72
	Night time 23:00 to 07:00 <sup>(2)</sup>	< 48	48-57	57-66	> 66
Mixed sources <sup>(4)</sup>	Day time 07:00 to 23:00	< 55	55-63	63-72	> 72
	Night time 23:00 to 07:00 <sup>(2)</sup>	< 45	45-57	57-66	> 66

**Notes**

<sup>(1)</sup> Noise levels: the noise level(s) ( $L_{Aeq, T}$ ) used when decided the NEC of a site should be representative of typical conditions.

<sup>(2)</sup> Night-time noise levels (2300-0700): sites where individual noise events regularly exceed 82 dB  $L_{Amax}$  (S time weighting) several times in any hour should be treated as being in NEC C, regardless of the  $L_{Aeq, 8 \text{ hour}}$  (except where the  $L_{Aeq, 8 \text{ hour}}$  already puts the site in NEC D).

<sup>(3)</sup> Air craft noise: daytime values accord with the contour values adopted by the Department of Transport which relate to levels measured 1.2m above open ground. For the same amount of noise energy, contour values can be up to 2 dB(A) higher than those of other sources because of ground reflection effects.

<sup>(4)</sup> Mixed sources: this refers to any combination of road, rail, air and industrial noise sources. The "mixed source" values are based on the lowest numerical values of the single source limits in the table. The "mixed source" NECs should only be used where no individual noise source is dominant.

To check is any individual noise source is dominant (for the purposes of this assessment) the noise level from the individual sources should be determined and then combined by decibel addition (remembering first to subtract 2 dB(A) from any aircraft noise contour values). If the level of any one source then lies within 2 dB(A) of the calculated combined value, that source should be taken as the dominant one and the site assessed against the appropriate NEC for that source, rather than using the "mixed source" NECs. If the dominant source is industrial noise see paragraph B17 of Annex B (of TAN 11).

If the contribution of the individual noise sources to the overall noise level cannot be determined by measurement and/or calculation, then the overall measured level should be used and the site assessed against the NECs for "mixed sources".

Source: TAN 11, Annex A, Table 2

In relation to noise from industrial or fixed mechanical sources TAN 11 recommends the use of BS 4142 as described in Section 2.5 below.

## 2.4 ProPG

Professional Practice Guidance on Planning and Noise (ProPG)<sup>4</sup> provides guidance which reflects the policy set out in National Planning Policy Framework (NPPF), Noise Planning Statement for England (NPSE) and Planning Practice Guidance - Noise (PPGN) specifically to be used for new residential developments.

ProPG encourages sustainable and better acoustic design for new residential developments and aims to protect people from the harmful effects of noise. The aims of ProPG are to:

- *“advocate full consideration of the acoustic environment from the earliest possible stage of the development control process;*
- *encourage the process of good acoustic design in and around new residential developments;*
- *outline what should be taken into account in deciding planning applications for new noise-sensitive developments;*
- *improve understanding of how to determine the extent of potential noise impact and effect; and;*
- *assist the delivery of sustainable development.”*

While noise can override other planning concerns, neither the NPSE nor the NPPF expect noise to be considered in isolation from economic, social or other environmental dimensions of Scheme. Instead, the NPPF states that economic, social and environmental gains from the development should be sought jointly.

ProPG states that there are no specific noise levels at which noise becomes a material consideration or at which development is prohibited; instead, the decision to grant or refuse planning consent should take account of the acoustic environment and in doing so consider:

- whether or not a significant adverse effect is occurring or likely to occur,
- whether or not an adverse effect is occurring or likely to occur,
- whether or not a good standard of amenity can be achieved.

This is consistent with the aims of the NPSE.

Two specific factors set out in PPGN, that influence whether noise could be a concern, are particularly relevant for residential development in areas subject to high levels of transportation noise. These are as follows:

- Consideration should *“be given to whether adverse internal effects can be completely removed by closing windows and, in the case of new residential developments, if the proposed mitigation relies on windows being kept closed most of the time. In both cases a suitable alternative means of ventilation is likely to be necessary”*
- *“If external amenity spaces are an intrinsic part of the overall design, the acoustic environment of those spaces should be considered so that they can be enjoyed as intended.”*

ProPG sets out a risk-based, sequential two-staged approach to address noise aspects of a Scheme. These stages are:

Stage 1 – an initial noise risk assessment of the Scheme site which should:

- provide an indication of the likely risk of adverse effects if no subsequent mitigation were to be included as part of the development plans; and

- indicate whether the proposed site is considered to pose a negligible, low, medium or high risk from a noise perspective

Stage 2 – a systematic consideration of four key elements which are:

- Element 1 – demonstrating a “Good Acoustic Design Process”
- Element 2 – observing internal “Noise Level Guidelines”
- Element 3 – undertaking an “External Amenity Area Noise Assessment”
- Element 4 – consideration of “Other Relevant Issues”.

The Stage 1 Risk assessment process is outlined in Figure 2.1. It shows how noise levels are associated with an increased risk of adverse effect from noise and the pre-planning advice associated with noise levels. It should be noted that a noise risk assessment based on the daytime and night-time  $L_{Aeq}$  noise levels at a site does not form the basis of a recommendation for residential development and so this will only form part of the overall assessment.

**Figure 2.1: Stage 1 – Initial site noise risk assessment**

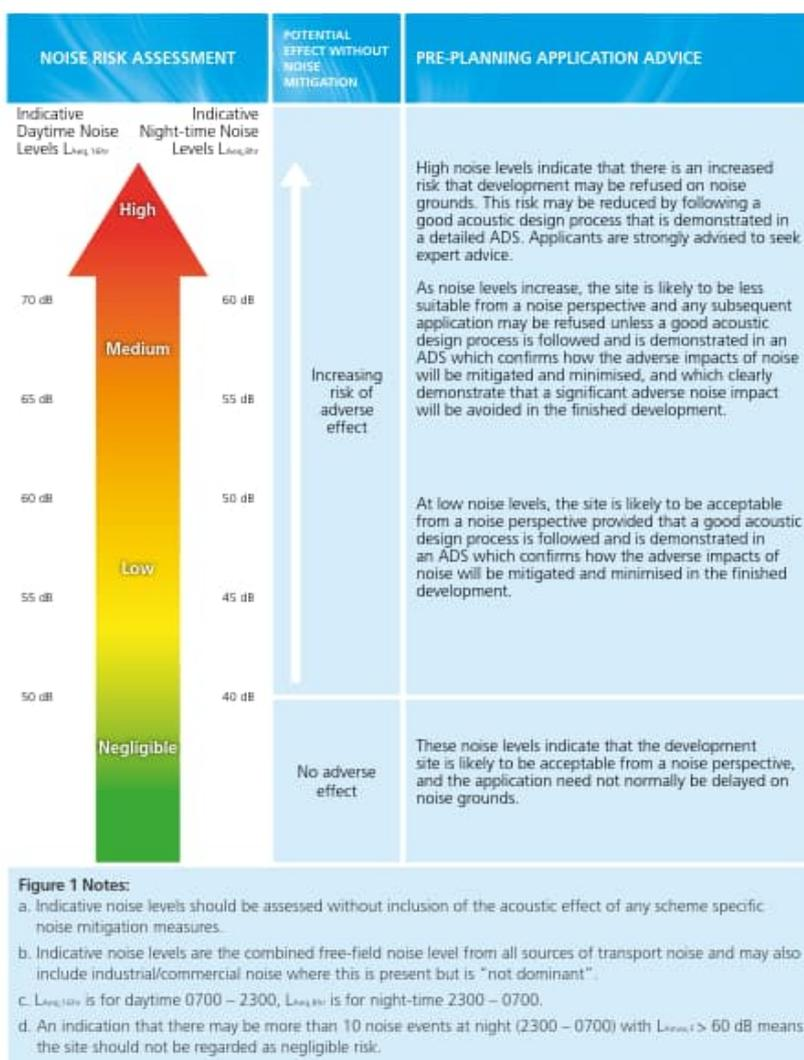

Source: ProPG

Section 5.0 of this report addresses the initial noise risk associated with this development based on ProPG Stage 1.

## 2.5 British Standard BS 4142:2014+A1:2019

British Standard BS 4142:2014+A1:2019, titled '*Methods for rating and assessing industrial and commercial sound*', provides a method for assessing the impact of industrial noise sources on residential receivers. In this sense, industrial noise sources include mechanical plant associated with new buildings and developments.

The relevant parameters are as follows.

- Background Sound Level in  $L_{A90,T}$ ;
- Specific Sound Level, or Source Sound Level, in  $L_{Aeq,T}$ ; and
- Rating Level in  $L_{Aeq,T}$  which is the specific sound level plus any penalties given for the characteristic features of the sound.

The rating method detailed within the standard is widely accepted as an effective means of assessing the significance of building plant noise. The level of sound from proposed new plant (the overall rating level) is predicted in terms of  $L_{Aeq}$  and compared to the existing background sound level, in terms of  $L_{A90}$ . The  $L_{A90}$  is to be representative of the period being assessed. If the specific sound includes tonal, impulsive or other features likely to attract attention, assessed at the off-site noise sensitive receptors (e.g. residential), a character penalty, from 2-18 dB (although unlikely to exceed 10 dB) is added to the specific sound level. Plant that contains these character features should therefore be avoided where practical.

The outcome of the assessment is defined in BS 4142:2014+A1:2019 with the following points that relate to the difference between the background sound level and the rating level:

- Typically, the greater this difference, the greater the magnitude of the impact
- A difference of around +10dB or more is likely to be an indication of a significant adverse impact, depending on the context
- A difference of around +5dB is likely to be an indication of an adverse impact, depending on the context

The lower the rating level is relative to the measured background sound level, the less likely it is that the specific sound source will have an adverse impact or a significant adverse impact.

Where the rating level does not exceed the background sound level, this is an indication of the specific sound source having a low impact, depending on the context.

## 2.6 British Standard BS 8233:2014

British Standard BS 8233:2014 titled '*Guidance on sound insulation and noise reduction for buildings*', provides guidance for the control of noise in and around new or refurbished buildings. Within the guidance, values for the internal ambient noise levels for different building uses are recommended. It states that it is 'desirable' that internal noise levels in dwellings do not exceed 35dB  $L_{Aeq,16hr}$  in living rooms and bedrooms during the day, 40dB  $L_{Aeq,16hr}$  in dining rooms during the day and 30dB  $L_{Aeq,8hr}$  in bedrooms at night. These values are often used to inform the level of sound insulation required in the walls, glazing and ventilation at the detailed design stage of the proposed residential developments.

BS 8233 provides some guidance on acceptable exterior noise levels within amenity spaces. It states: "*For traditional external areas that are used for amenity space, such as gardens and patios, it is desirable that the external noise level does not exceed 50 dB  $L_{Aeq,T}$ , with an upper guideline value of 55 dB  $L_{Aeq,T}$  which would be acceptable in noisier environments. However, it is also recognized that these guideline values are not achievable in all circumstances where development might be desirable.*"

## 2.7 World Health Organization guidance

The World Health Organization (WHO) Guidelines for Community Noise and Night Noise Guidelines provides guidance on maximum noise levels within residential dwellings during night-time periods which can cause sleep disturbance. Guidance advises that internal noise levels should not exceed 45dB  $L_{Amax,f}$  (not to be exceeded 10 to 15 times a night) due to individual events.

The WHO Environmental Noise Guidelines for the European Region provides evidence-based recommendations on the health effects of noise. The guidelines complement the expert-based recommendations of the WHO 'Night Noise Guidelines' (2009) (NNG). Guidelines provide source specific recommendations for road traffic, railway, aircraft and wind turbine noise, and indoor as well as outdoor exposure levels for leisure noise.

## 2.8 British Standard BS 7445:2003

BS 7445:2003 '*Description and measurement of environmental noise*' sets out the basic requirements for the measurement of environmental noise on site and its processing and description using the various environmental noise parameters.

## 3 Survey methodology

### 3.1 Measurement procedure

A noise survey was undertaken in December 2023 and January 2024.

The survey comprised both unattended, continuous long-term (LT) measurement and attended, short-term measurements (ST). Automatic unattended monitoring was conducted from Saturday 09 December to Thursday 21 December 2023 and attended measurements were conducted on Friday 05 January 2024.

Measurement positions were selected to be representative of the noise climate across the site and at the nearest sensitive receptors potentially subject to operational noise as a result of the development.

All equipment used for baseline noise measurements complied with Class 1 requirements given in BS EN 61672<sup>1</sup>. The sound level meters were fitted with a microphone and windshield suitable for outdoor measurement. All measurements, both Short Term (ST) and Long Term (LT) were taken at a height of between 1.2m and 1.5m above local ground. The long term (LT) measurement was located at the eastern boundary of the site.

Unless otherwise stated, all ST measurement locations were 'free-field' meaning they are at least 3.5m from an acoustically reflective façade. Measurements were completed by a Mott MacDonald acoustician competent in environment noise monitoring and completed in accordance with the principles of BS 7445<sup>2</sup>.

The calibration level of all equipment was checked before and after the measurement periods and no significant changes were noted.

Equipment was configured to measure using the fast time weighting and A-frequency weighting in 15-minute intervals for both the LT and ST measurements.

Noise levels were measured in decibels for a range of stated descriptors that are defined below.

- $L_{Amax}$  – the highest value of the A-weighted sound pressure level with a specified time weighting that occurs during a given event.
- $L_{Aeq,T}$  – also referred to as the continuous equivalent noise level, it is the A-weighted sound pressure level that is the same amount of sound energy as the time varying noise over the same period of time (T).
- $L_{A10,T}$  – the A-weighted sound pressure level that is exceeded for 10% of a given time interval (T).
- $L_{A90,T}$  – also referred to as the background noise level, it is the A-weighted sound pressure level that is exceeded for 90% of a given time interval (T).

A-weighting – As seen in the parameters above, this is a frequency weighting designed to mimic the frequency response of the human ear by providing corrections for the frequencies which the human ear is less sensitive to.

---

<sup>1</sup> BS EN 61672-1:2013 'Electroacoustics-Sound level meters Part 1: Specifications.'

<sup>2</sup> British Standards Institution BS 7445 Description and measurement of environmental noise. Part 1: Guide to quantities and procedures, 2003,

### 3.2 Measurement locations

Measurement locations and details are provided in Figure 3.1 and Table 3.1.

**Figure 3.1: Noise measurement locations**

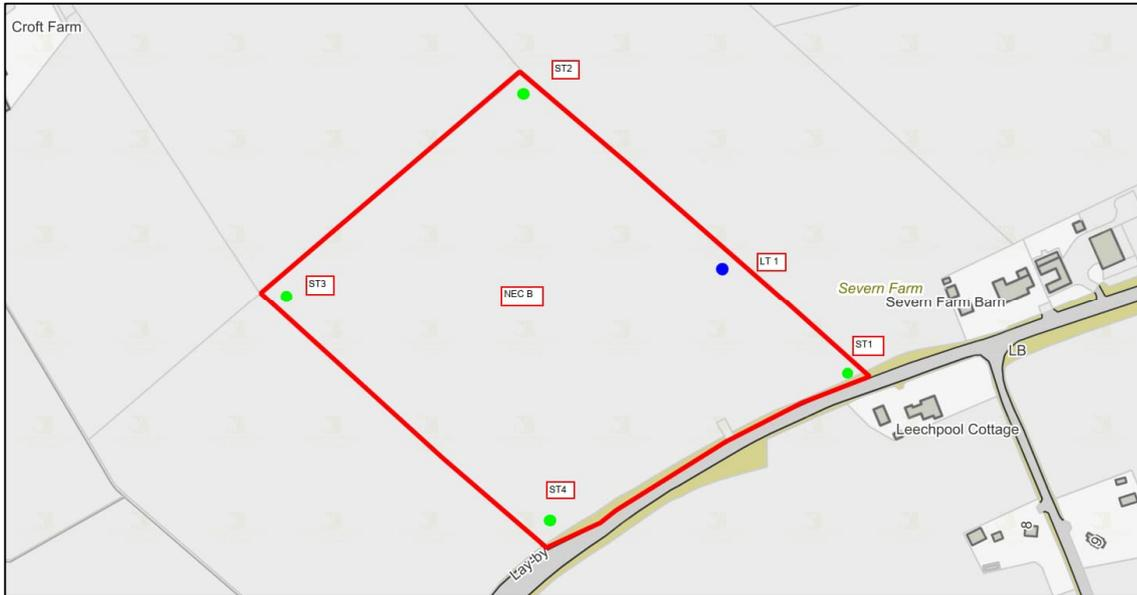

Source: © OpenStreetMap contributors (data is available under the Open Database Licence, <https://www.openstreetmap.org/copyright>) with Mott MacDonald mark-up

**Table 3.1: Noise measurement location details**

Measurement ID	'what3words' <sup>3</sup> location reference	Measurement type	Microphone height from existing ground (m)
LT1		Free field	1.2m / 1.5m
ST1		Free field	1.2m
ST2		Free field	1.2m
ST3		Free field	1.2m
ST4		Free field	1.2m

Source: Mott MacDonald and <https://what3words.com>

### 3.3 Equipment

A full inventory of all equipment used during the baseline noise surveys is shown in Table 3.2

**Table 3.2: Inventory of noise measurement equipment**

Item	Model	Serial Number	Calibrated until
LT	Rion NL-52	1265461	17/01/24
ST	Rion NL-52	1176426	04/05/24
Calibrator	Rion NC75	34913591	21/02/2023

Source: Mott MacDonald

<sup>3</sup> <https://what3words.com> - Location referencing system that is based on dividing the globe into 3 metre squares and assigning a unique combination of three words to each square

### 3.4 Weather conditions

The weather conditions during the attended survey (ST measurements and installation) were considered suitable for undertaking noise measurements.

Weather conditions were measured at Crick Road during the survey and reported below.

During the automatic unattended noise survey there were periods when wind speeds exceeded 5m/s and periods which were subject to rain. These periods have been excluded during the processing of the measured noise data.

Table 3.3 presents details of the weather conditions.

**Table 3.3: Weather summary**

Date	Average Temp (Degrees C)	Average Wind Speed (m/s)	Average Rainfall (mm)
09/12/2023			
10/12/2023	10	2	0
11/12/2023	10	2	0
12/12/2023	10	1	0
13/12/2023	10	2	0
14/12/2023	6	2	0
15/12/2023	6	0	0
16/12/2023	6	1	0
17/12/2023	10	2	0
18/12/2023	10	3	0
19/12/2023	11	3	0
20/12/2023	9	1	0
21/12/2023	9	2	0

Source: Mott MacDonald

### 3.5 Limitations

Inevitably, there is a degree of variation in measured noise levels. Contributory factors to this variation include tolerances in instrumentation readings, meteorological conditions, and the inherent difference in the acoustic environment during the course of the day and indeed over longer periods as the noise sources influencing a given location vary. Every effort has been made to limit variation in the measurements reported. The following efforts have been made in order to reduce measurement uncertainty.

- Undertaking surveys with appropriately qualified and trained acoustic engineers
- Use of measurement equipment calibrated to appropriate standards by accredited bodies and checked on site using calibrated reference sound sources
- Following best practice methodology for environmental noise measurement set out in BS 7445
- Measuring under appropriate meteorological conditions
- Measuring at times and locations that are representative of the noise climate at any particular location
- Analysing the data to notice trends and anomalies, ensuring the data is representative for the location



## 4 Measurement results

This section presents the full data results for both Long-Term (LT) and Short-term (ST) noise measurements.

For the purposes of the assessment, only the  $L_{Aeq}$  and  $L_{A90}$  parameters are presented for the LT measurements and  $L_{Aeq}$  for the ST measurements.

LT  $L_{Aeq}$  noise measurements are shown for daytime (07:00 to 23:00), and night-time (23:00 to 07:00) in accordance with guidance provided by TAN 11 and BS 4142.

LT  $L_{A90}$  noise measurements have been analysed to determine a single number value which is considered to be the representative background noise level during the relevant assessment periods in accordance with guidance provided by BS 4142. In this case the lowest 10<sup>th</sup> percentile value of the  $L_{A90,15min}$  values has been used.

### 4.1 Long term

Position LT1 was located at the eastern edge of the field. It was installed at 11:01 on 09 December 2023 and collected at 10:01 on 21 December 2023.

The major noise source was road traffic noise from the B4245 and A48 roads.

The levels relevant to the assessment are summarised in Table 4.1 below. Figure 4.1 shows the time history of the measurement.

Partial measurement periods at the start and end of the survey have been included (shown with one asterisk).

**Table 4.1: LT1 measurement results (free-field measurement)**

	Average $L_{Aeq, T}$ dB		$L_{A90, T}$ dB	
	Day (07:00-23:00)	Night (23:00-07:00)	Day (07:00-23:00)	Night (23:00-07:00)
9 December 2023	59.6	50.3	48.8	36.0
10 December 2023	59.4	53.7	46.9	38.9
11 December 2023	54.6	52.3	44.5	38.1
12 December 2023	57.1	47.6	44.6	35.0
13 December 2023	52.6	49.9	44.3	37.6
14 December 2023	54.1	51.2	43.9	39.8
15 December 2023	55.5	48.4	44.8	33.7
16 December 2023	54.9	48.4	42.6	36.2
17 December 2023	54.4	49.9	41.6	36.7
18 December 2023	56.2	51.4	47.5	38.7
19 December 2023	55.1	48.2	44.4	34.7
20 December 2023	59.6	50.3	48.8	36.0
21 December 2023	59.4	53.7	46.9	38.9
<b>Baseline level for assessment</b>	<b>55.8</b>	<b>50.1</b>	<b>44.9</b>	<b>36.9</b>

**Figure 4.1: LT1 plot of results of the long term noise monitoring**

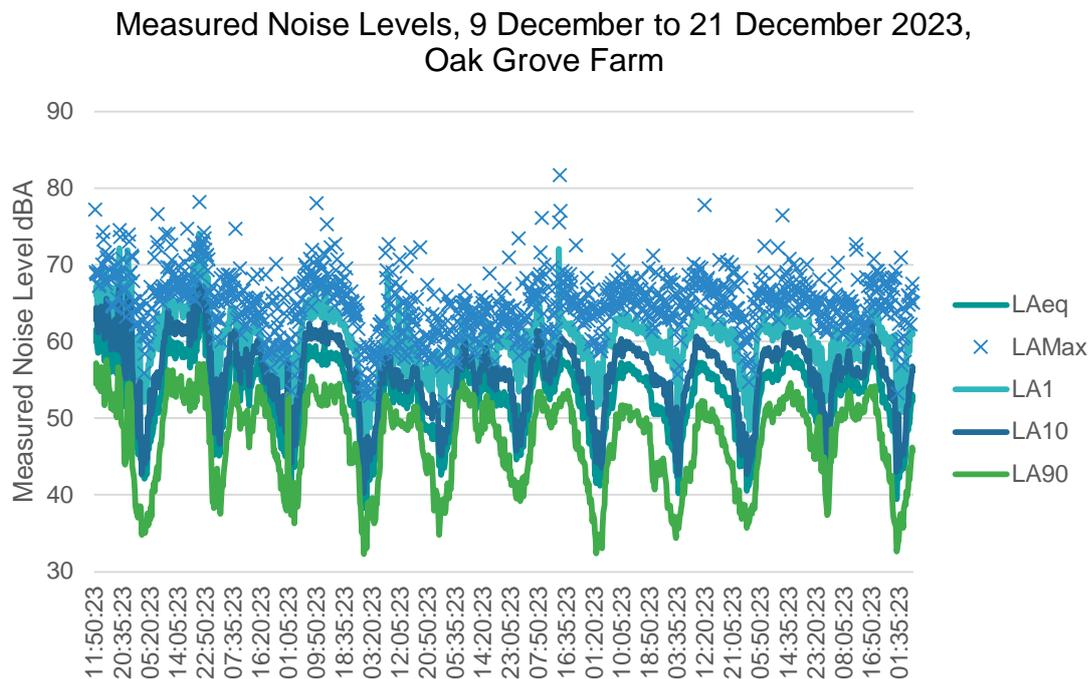

**4.2 Short term**

The noise climate of these measurement positions was dominated by road traffic noise from the B4245 road and to a lesser extent the A48 road.

In order to determine the geographical variation in noise level across the site relative to the measured noise levels at LT1 an automatic unattended noise logger was set up at LT1 during the attended measurements. This was set up such that 5-minute samples at the ST locations

were synchronous with the 5-minute samples at LT1. The difference between the measured  $L_{Aeq,5\text{ minute}}$  samples were then used to estimate the  $L_{Aeq, 16hr}$  and  $L_{Aeq, 8hr}$  at the ST locations. This comparison is shown in Appendix B.

The supplementary ST noise levels and comments on the main noise sources are summarised in Table 4.2 below.

All levels have been rounded to the nearest whole number.

**Table 4.2: Summary of ST measurements (5 minutes for each measurement)**

ST	Date	Start time	$L_{Aeq, T}$ dB	$L_{Amax, T}$ dB	$L_{A10, T}$ dB	$L_{A90, T}$ dB	Main noise source and comments
SE		13:45	65.6	76.1	73.4	69.8	Traffic Noise from B4245, and A48
SE		13:50	65.2	77.4	74	69.4	Traffic Noise from B4245, and A48
SE		13:55	66.3	75.2	73.5	70.6	Traffic Noise from B4245, and A48
SE		15:05	68.4	81.9	77.9	72.1	Traffic Noise from B4245, and A48
SE		15:10	67.8	78.3	75.5	71.8	Traffic Noise from B4245, and A48
NE		14:10	51.4	58.6	56.5	53.5	Traffic Noise from B4245, and A48
NE		14:15	53.2	59.6	57.3	55.3	Traffic Noise from B4245, and A48
NE		15:20	54.7	63.2	60.4	57.7	Traffic Noise from B4245, and A48
NE		15:25	55.7	66.4	62	58.9	Traffic Noise from B4245, and A48
NW		14:35	51.2	65.2	56.5	54.2	Traffic Noise from B4245, and A48
NW		14:40	51.8	60.6	57.2	54.1	Traffic Noise from B4245, and A48
NW		15:35	50.6	58.0	56.2	52.6	Traffic Noise from B4245, and A48
NW		15:40	50.5	58.7	55.3	52.9	Traffic Noise from B4245, and A48
SW		14:50	65.5	74.6	73.2	70.1	Traffic Noise from B4245, and A48
SW		14:55	66.6	76.8	74.7	70.3	Traffic Noise from B4245, and A48
SW		15:50	65.3	75.7	73.2	69.3	Traffic Noise from B4245, and A48
SW		15:55	64.9	75.2	72.6	69	Traffic Noise from B4245, and A48

# 5 Assessment

## 5.1 TAN 11

The measured  $L_{Aeq,16hr}$  and  $L_{Aeq,8hr}$  values at each of the measurement locations have been used to determine which areas of the site are within the NEC Categories shown in Table 2.3. These areas have been drawn in Figure 5.1 below:

**Figure 5.1: Areas within Tan 11 NEC Categories**

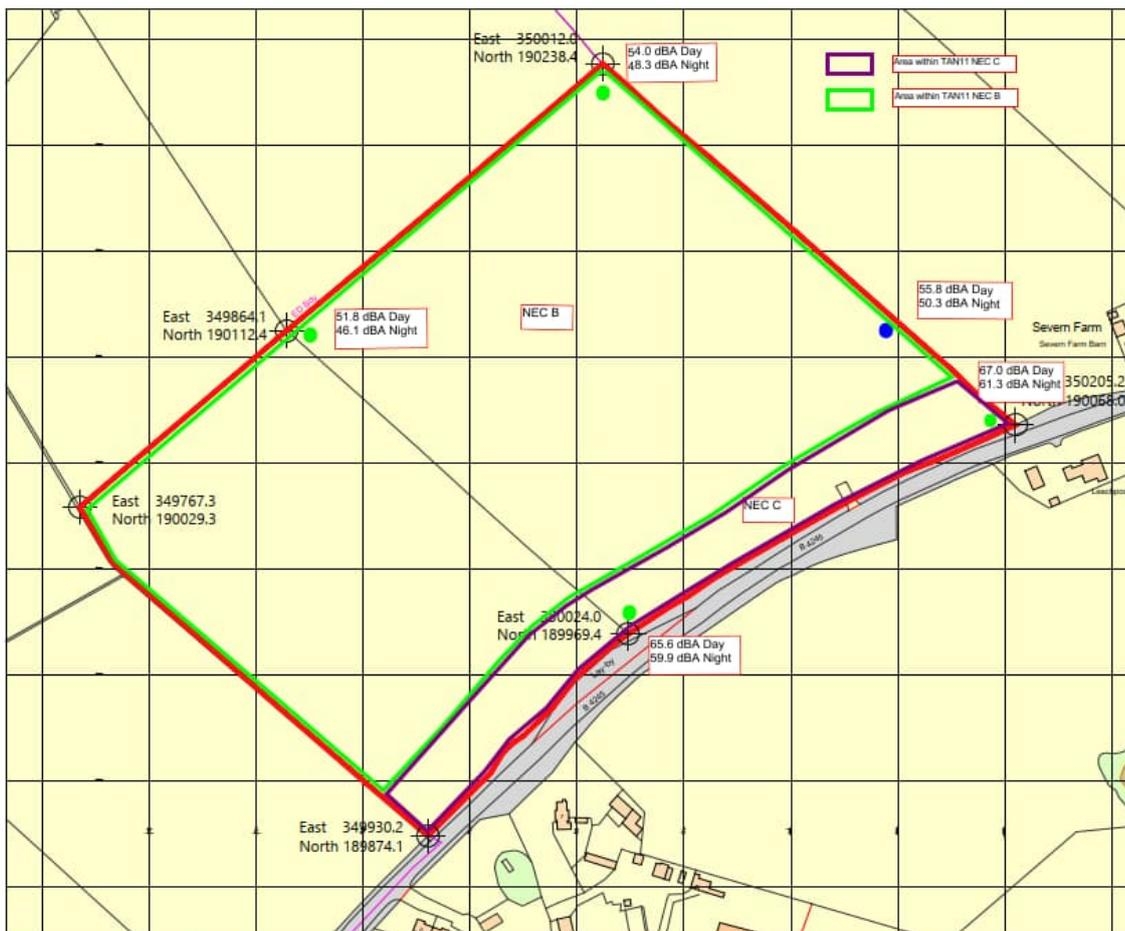

Source: Mott MacDonald

## 5.2 ProPG

Measured  $L_{Aeq}$  Levels on site at LT1, approximately 95m from the B4245 were 55.8dBL $_{Aeq,16hr}$  during daytime and 50.5dBL $_{Aeq,8hr}$  at night. Comparing these levels with the chart shown in Figure 2.1 indicates that the ProPG Stage 1 Risk assessment methodology would assign a 'Medium' risk during daytime and night.

Calculated  $L_{Aeq,16hr}$  levels up to 67.0dB and up to 61.3dB were measured at the short-term measurement locations closest to the B4245 road. These monitoring locations were approximately 10m from the edge of the B4245 road. Comparing these levels with the chart shown in Figure 2.1 indicates that the ProPG Stage 1 Risk assessment methodology would assign a 'Medium' risk during daytime due to noise and "medium/high" risk at night, to the site.

ProPG is generally aimed at developments of substantial bricks and mortar or other relatively massive constructions. The Gypsy and Traveller site would however accommodate mobile homes. These have lower sound insulation values than more substantial homes and this needs to be taken into account.

BS 8233 states that it is 'desirable' that internal noise levels in dwellings do not exceed 35dB  $L_{Aeq,16hr}$  in living rooms and bedrooms during the day, 40dB  $L_{Aeq,16hr}$  in dining rooms during the day and 30dB  $L_{Aeq,8hr}$  in bedrooms at night. It is estimated that a mobile home may provide a sound insulation value of around 15dB to 20dB with windows closed.

Based on the measured noise levels at 95m from the B4245 road, internal levels would be estimated to be around 41dB  $L_{Aeq,16hr}$  during daytime and 35dB  $L_{Aeq,8hr}$  at night. These are above the internal noise level recommendations provided by BS 8233.

In order to achieve the internal noise levels within mobile homes recommended by BS 8233 by distance attenuation alone would not be feasible. The calculated  $L_{Aeq,16hr}$  at the northern end of the site was 54dB during daytime and the  $L_{Aeq,8hr}$  at night was 48dB. Internal noise levels with a mobile home would therefore be 39dB at this location during daytime and 33dB at night. These levels still exceed the internal recommendations of BS8233.

It would however be possible to construct an earth bund along the southern boundary of the site which would significantly attenuate road traffic noise levels from the B4245 road. Given that the site slopes downwards towards the north, this bund may be relatively low to achieve the required attenuation.

It is therefore considered that the northern part of the site may be suitable for development as a Gypsy and Traveler Site provided mitigation measures are implemented.

### 5.3 BS 4142

There are not expected to be any major noise sources associated with the Gypsy and Traveller site, but minor plant such as toilet extract fans, generators and air conditioning units etc may potentially be expected.

Background  $L_{A90}$  noise levels of 50.1dB during daytime and 36.9dB during night-time were measured on site. BS 4142 state that "*where the rating level does not exceed the background sound level, this is an indication of the specific sound source having a low impact, depending on the context*" and the background noise level is often used as a noise limit for noise emissions from new developments. These noise levels may be used as limits, applied at the nearest residential receptors for noise levels from any mechanical plant associated with the site.

It is therefore recommended that noise levels created by any plant associated with the proposed Gypsy and Traveller site should be limited to 37dB  $L_{Aeq,15minute}$  at the nearest potentially affected residences during night time and 50 $L_{Aeq,1hr}$  during daytime.

### 5.4 BS 8233

BS 8233 provides some guidance on acceptable exterior noise levels within amenity spaces. Its states: "*it is desirable that the external noise level does not exceed 50 dB  $L_{Aeq,T}$ , with an upper guideline value of 55 dB  $L_{Aeq,T}$  which would be acceptable in noisier environments.*"

The measured noise levels at LT1, and ST1 to ST4 exceeded 50 dB  $L_{Aeq,T}$  during daytime.

It would therefore also be advisable to provide localised noise screening from the B4252 for the outdoor amenity areas on the site. This may take the form of solid noise barriers or landscaped bunds between the B4245 road and the site.

## 5.5 World Health Organization guidance

'The World Health Organization (WHO) Guidelines for Community Noise and Night Noise Guidelines advises that internal noise levels should not exceed 45dB  $L_{Amax,f}$  (not to be exceeded 10 to 15 times a night) due to individual events'.

Based on an attenuation of 15dB between external and internal noise level for a mobile home the internal 45dB  $L_{Amax}$  criterion 10 to 15 times per night corresponds to 60 dB  $L_{Amax}$  externally. Analysis of the LT data measured at 95m from the B4245 shows that in most nighttime periods this criterion is exceeded in most 15minute sample periods. On average the  $L_{Amax,15min}$  exceeded 60dBA 25 times per night with an average exceedance of 4.6dBA (above 60dBA). The Maximum  $L_{Amax,15minute}$  was 73.5dBA.

It should be noted that this is based on the  $L_{Amax}$  across 15minute samples. The  $L_{Amax}$  criterion of 60dBA may be exceeded several times in a 15minutes sample but only the highest would show up in this analysis.

In line with other aspects of this noise assessment, whilst exceedances of  $L_{Amax}$  noise criteria occur these may potentially be mitigated by the construction of an earth bund along the southern boundary of the site. The efficacy of a proposed bund may be determined by further and more detailed analysis.

## 6 Conclusions

This report documents the findings of the noise monitoring and assessment undertaken for the proposed Gypsy and Traveller site at Oak Grove Farm.

Applying TAN11 shows that area closest to the B4245 road falls within NEC C in which *'Planning permission should not normally be granted. Where it is considered that permission should be given, for example, because there are no alternative quieter sites available, conditions should be imposed to ensure a commensurate level of protection against noise.'*

Beyond approximately 60m from the B4245 road, the site falls within NEC B in which *'Noise should be taken into account when determining planning applications and, where appropriate, conditions imposed to ensure an adequate level of protection'*.

Measured noise levels have also been used to assess the risk of noise having an adverse impact upon the site in accordance with the ProPG Stage 1 Risk Assessment method. This assessment shows there is a *Medium/High* risk of noise adversely impacting the southern part of the site closest to the B4245 road. At 95m from the B4245 road however there is a *Medium* risk according to ProPG.

However, the above guidance is intended primarily to deal with dwellings which are constructed from bricks and mortar. Mobile homes provide significantly lower levels of sound attenuation between exterior and interior. It is estimated that a mobile home may provide a sound insulation value of around 15dB to 20dB with windows closed.

Based on the levels of noise measured on the site, interior noise levels would exceed the recommended noise levels given in BS 8233 across the whole site. However, if an earth bund or solid noise barrier were constructed along the southern edge of the site this may provide sufficient sound attenuation that the internal noise criteria recommended by BS 8233 would be met within mobile homes on the northern part of the site.

Measurements show that  $L_{Amax}$  noise levels at night are likely to exceed the WHO night noise guideline of 45dB  $L_{Amax,f}$  more than 10 to 15 times a night inside a mobile home. The average exceedance measured would be around 5Db. This may potentially be mitigated by a barrier/bund along the southern boundary of the site closest to the B4245 road.

Exterior noise levels on the site would exceed 50dB  $L_{Aeq,T}$  during daytime. It would therefore be advisable to provide localised noise screening for the outdoor amenity areas or a barrier/bund along the southern boundary of the site closest to the B4245 road.

A noise level limit of 50dB  $L_{Aeq,1hr}$  during daytime and 37dB  $L_{Aeq,15min}$  at night are proposed for fixed plant noise emissions from the site.

If planning permission is granted, a Stage 2 Acoustic Assessment should be conducted in which the landscape design of the proposed site should be developed to incorporate acoustic screening for the plots closest to the southern boundary.





## A. Acoustic Glossary

<b>A-weighting</b>	The human ear also has a non-linear frequency response, being most sensitive in the frequency range 1 kHz to 4 kHz and is less sensitive at higher and lower frequencies. The A-weighting is a frequency function commonly applied to the linear output of a microphone to simulate the subjective response of the ear. A-weighted levels are usually indicated by a subscript A or postscript (A).
<b>Z-weighting</b>	A flat frequency response between 10Hz and 20kHz excluding microphone response.
<b>Decibel</b>	Sound and noise are commonly described using the decibel (dB) scale, which is logarithmic in nature to relate to the response of the human ear. The range of human hearing commonly varies from the threshold of audibility (0dB) to the threshold of pain (120dB). Such limits are seldom experienced in practice and typical levels might vary between 30dB in a quiet bedroom at night to 90dB at the kerbside of a busy road.
<b>Sound Pressure Level (Lp)</b>	The logarithmic measure of the root mean square sound pressure relative to a reference sound pressure. The reference sound pressure in air is 20 micro Pascals and represents the threshold of hearing in a healthy young person.
<b>Equivalent continuous noise level Leq</b>	The equivalent continuous noise level, $L_{Aeq,T}$ , is the notional level of a steady sound which, at a given position and over the same period of time (T), would deliver the same sound energy as the fluctuating one. Used to quantify time-varying noise from industrial sources.
<b>Maximum sound pressure level L(max)</b>	The lowest sound pressure level reached within the measurement period.
<b>Minimum sound pressure level L(min)</b>	The lowest sound level reached within the measurement period.
<b>Ln</b>	A statistical parameter where the sound pressure level exceeded for a 'n' percentage of the measurement period.
<b>Fast weighting</b>	The sound pressure level is weighted to the response time of the ear (125ms).
<b>Slow weighting</b>	The sound pressure level is weighted to the response time of 1 second.

## B Comparison between 5 minute sample measurements at ST and LT locations

ST							LT1				
	Time	L <sub>Aeq</sub>	L <sub>Amax</sub>	L <sub>A10</sub>	L <sub>A90</sub>	Difference in L <sub>Aeq</sub> between ST and LT1	Time	L <sub>Aeq</sub>	L <sub>Amax</sub>	L <sub>A10</sub>	L <sub>A90</sub>
SE	13:45	65.6	76.1	69.8	52.6	11.4	13:45	54.2	74.7	60.7	46.6
SE	13:50	65.2	77.4	69.4	48.7	10.3	13:50	54.9	61.9	59.8	48.7
SE	13:55	66.3	75.2	70.6	53.8	11.6	13:55	54.7	61	59.4	50.8
SE	15:05	68.4	81.9	72.1	53	11.5	15:05	56.9	64.4	62.6	53
SE	15:10	67.8	78.3	71.8	53.2	11	15:10	56.8	63.3	61.8	53.1
						11.16					
NE	14:10	51.4	58.6	53.5	48.4	-5.8	14:10	57.2	64.3	62	52.4
NE	14:15	53.2	59.6	55.3	50.6	-0.8	14:15	54	62.1	59.8	49.8
NE	15:20	54.7	63.2	57.7	49.8	-0.9	15:20	55.6	66.7	62.3	51.5
NE	15:25	55.7	66.4	58.9	50.1	0.2	15:25	55.5	64.7	61.1	51
						-1.825					
NW	14:35	51.2	65.2	54.2	47.2	-2.9	14:35	54.1	60.5	58.4	50.8
NW	14:40	51.8	60.6	54.1	48.5	-3.1	14:40	54.9	61.8	59.6	51.6
NW	15:35	50.6	58	52.6	47.7	-4.5	15:35	55.1	63.6	61	51.6
NW	15:40	50.5	58.7	52.9	47.1	-5.6	15:40	56.1	65.4	64.1	52.5
						-4.025					
SW	14:50	65.5	74.6	70.1	51.5	9.5	14:50	56	64	61.9	51.8
SW	14:55	66.6	76.8	70.3	53.7	10.4	14:55	56.2	62.5	61.1	52
SW	15:50	65.3	75.7	69.3	51.7	9.5	15:50	55.8	63.3	61.4	52.2
sw	15:55	64.9	75.2	69	50.9	9.6	15:55	55.3	64.5	60.9	51.9
						9.75					



This page is intentionally left blank



# **Proposed Gypsy and Traveller Site Langley Close, Magor**

Land Contamination Assessment

February 2024

This page left intentionally blank for pagination.

Mott MacDonald  
10 Temple Back  
Bristol BS1 6FL  
United Kingdom

T +44 (0)117 906 9500  
mottmac.com

# **Proposed Gypsy and Traveller Site Langley Close, Magor**

Land Contamination Assessment

February 2024

# Issue and Revision Record

Revision	Date	Originator	Checker	Approver	Description
P01	February 2024	E Omo-Aghoja	N Cummins	C Williams	First Issue

**Document reference:** 100115516 | LQ001 | P01 |

**Information class:** Standard

This document is issued for the party which commissioned it and for specific purposes connected with the above-captioned project only. It should not be relied upon by any other party or used for any other purpose.

We accept no responsibility for the consequences of this document being relied upon by any other party, or being used for any other purpose, or containing any error or omission which is due to an error or omission in data supplied to us by other parties.

This document contains confidential information and proprietary intellectual property. It should not be shown to other parties without consent from us and from the party which commissioned it.

---



# Contents

<b>1</b>	<b>Introduction</b>	<b>1</b>
1.1	Details of Scheme	1
1.2	Report Scope	1
1.3	Report Objectives	1
1.4	Methodology	1
1.5	Limitations	2
<b>2</b>	<b>Sources of information</b>	<b>3</b>
2.1	Historical Ordnance Survey Maps	3
2.2	British Geological Survey (BGS)	3
2.3	Previous Desk Studies and Ground Investigations	3
2.4	Mining, quarrying and mineral deposits	3
2.5	Land mass movement	3
2.6	Hydrology and hydrogeology	4
2.7	Unexploded Ordnance	4
2.8	Radon	4
<b>3</b>	<b>Site Description</b>	<b>5</b>
3.1	General	5
3.2	Topography	6
3.3	Geomorphology	6
3.4	Historic development and current land use	6
3.5	Unexploded Ordnance	8
3.6	Other information	8
3.7	Site Reconnaissance	10
<b>4</b>	<b>Ground Conditions</b>	<b>12</b>
4.1	Topsoil	12
4.2	Artificial Ground	12
4.3	Superficial Deposits	12
4.4	Bedrock Geology	12
4.5	Land Mass Movement	12
4.6	Mining and Quarrying	13
4.7	BGS Ground Stability Hazards	13
4.8	Hydrology and Flooding	13
4.9	Hydrogeology	14
4.10	Historical Ground Investigations	14
4.11	Ground Gas Generation Potential	15

<b>5</b>	<b>Preliminary Ground Model</b>	<b>16</b>
5.1	Ground Model	16
5.2	Groundwater	16
5.3	Obstructions	16
<b>6</b>	<b>Preliminary Contamination Risk Assessment</b>	<b>17</b>
6.1	Preliminary Conceptual Model Methodology	17
6.2	Preliminary Risk Assessment Methodology	17
6.3	Preliminary Conceptual Site Model	19
<b>7</b>	<b>Conclusions</b>	<b>22</b>
7.1	Ground Conditions	22
7.2	Recommendations	23
<b>A.</b>	<b>Groundsure Environmental and Geo Insight Report</b>	
<b>B.</b>	<b>Historical Borehole Logs</b>	
<b>C.</b>	<b>Site Walkover Survey Photographs</b>	

# 1 Introduction

## 1.1 Details of Scheme

Monmouthshire County Council (MCC) has a legal and moral duty to ensure everyone has access to good quality homes. MCC recognises that safe, culturally appropriate accommodation is necessary for individuals to flourish in other parts of their lives. In accordance with the Housing (Wales) Act, 2014, MCC has identified a need for additional sites to house the Gypsy and Traveller families already living in Monmouthshire. Three Council-owned sites in Monmouthshire have been identified as potentially suitable to meet the current needs for the Gypsy and Traveller community.

Mott MacDonald has been appointed by MCC to provide a land contamination report as part of MCC's Gypsy and Traveller Accommodation Assessment (GTAA) identification study for the Langley Close site in Magor, Monmouthshire (hereafter referred to as "the proposed Gypsy and Traveller site" or simply "the site"), one of the three council-owned identified sites for potential development. The proposed Gypsy and Travellers site is understood to comprise the construction of up to six pitches that will include parking and a collective utility block with access gained via St Bride's Road which runs along the eastern boundary of the site.

The site is located in Monmouthshire, south-east Wales in the village of Magor. The site is roughly trapezoidal in shape and centred at National Grid Reference (NGR) ST 42182 87741. For the purpose of this report a reporting buffer of 500m has been identified around the site extent to identify features within the surrounding area which may impact upon the site.

## 1.2 Report Scope

The scope of this desk study is to:

- Review freely available information, and client supplied data, for an understanding of the proposed development
- Review and summarise site-specific information
- Develop a preliminary ground model for the site
- Identify ground related risks which may impact future ground investigations (GI)
- Develop a conceptual site model and identify potential contaminant linkages present at the site
- Undertake a Preliminary Contaminated Land Risk Assessment (CLRA), and
- Provide recommendations (if necessary) for further assessments, including project specific investigations.

## 1.3 Report Objectives

The key objective of this report is to provide a high-level assessment of the likely ground conditions underlying the site and their potential geo-environmental impact upon the scheme and make recommendations on how these risks can be managed.

## 1.4 Methodology

This desk-based review and report have been completed in accordance with the following guidance documents and standards:

- Development of Land Affected by Contamination: A Guide for Developers. Welsh Government Ver 4, September 2023
- BS10175:2011 (+A2:2017), Investigation of Potentially Contaminated Sites, Code of Practice, December 2017
- CIRIA C552, Contaminated Land Risk Assessment - A Guide to Good Practice, January 2001.

## 1.5 Limitations

This report has been prepared for the titled project or named part thereof and should not be relied upon or used for any other project without an independent check being carried out for the suitability and written authority from Mott MacDonald Ltd being obtained.

Mott MacDonald Ltd accepts no responsibility or liability for the consequences of this document being used for the purpose other than the proposed for which it was commissioned. Any person using or relying on the document for such other purposes agrees – with use or reliance to be taken as confirmation, that this indemnifies Mott MacDonald Ltd for all loss or damage resulting from therein. Mott MacDonald Ltd accepts no responsibility or liability for this document to any party other than the person by whom it was commissioned.

To the extent that this document is based on information supplied by other parties, Mott MacDonald Ltd accepts no liability for any loss or damage suffered by the Client stemming from any conclusions based on data supplied by parties other than Mott MacDonald Ltd and used by Mott MacDonald Ltd in preparing this report.

To the extent that this document is based on information obtained in previous or recent ground investigations, persons using or relying on it should recognise that such investigation can examine only a fraction of the subsurface conditions. In any ground investigation there remains the risk that pockets or 'hotspots' of contamination or other ground hazards may not be identified, because investigations are necessarily based on sample at localised points. Certain indicators or evidence of hazardous substance or conditions may have been outside the portion of the subsurface investigated or monitored, and thus may not have been identified or their full significance appreciated.

Mott MacDonald Ltd is not insured for, and therefore will not undertake surveys to identify any asbestos or provide guidance on the treatment of asbestos, or similarly for toxic mould. Should the presence of asbestos or toxic mould be suspected during the course of the study, Mott MacDonald Ltd would recommend the appointment of a specialist contractor to address the issue and would not provide advice on the risk or remedial measures.

This review considers the risks associated with the proposed use of the site only. This report should not be relied upon by any other third party.

## 2 Sources of information

### 2.1 Historical Ordnance Survey Maps

The following sources of information have been used as part of the historical map review process:

- Groundsure Environmental and Geo Insight Report (Appendix A)
- National Library of Scotland Side-by-Side Map Viewer<sup>1</sup>
- Google Earth Pro<sup>2</sup>

### 2.2 British Geological Survey (BGS)

The following sources of information have been used to determine the geological conditions underlying the site:

- BGS GeoIndex Onshore<sup>3</sup>
- BGS Sheet 250 Chepstow (1:50,000) Bedrock and Drift<sup>4</sup>
- Geology of the country around Monmouth and Chepstow: Explanation of sheets 233 and 250<sup>5</sup>
- BGS Lexicon of Named Rock Units<sup>6</sup>

### 2.3 Previous Desk Studies and Ground Investigations

Mott MacDonald is not aware of any desk studies or ground investigations having been carried out on the site previously. However historical ground investigation information from works carried out in the vicinity of the site was reviewed using the BGS GeoIndex<sup>3</sup> online viewer and historical borehole logs, copies of which can be found in Appendix B.

### 2.4 Mining, quarrying and mineral deposits

The BGS GeoIndex<sup>3</sup> and Coal Authority Interactive Online Map Viewer<sup>7</sup> were reviewed as part of this study and are discussed in Section 4.6.

### 2.5 Land mass movement

Land mass movement was reviewed as part of this study using the BGS GeoIndex Online Map Viewer<sup>3</sup>.

---

<sup>1</sup> [Side by side georeferenced maps viewer - Map images - National Library of Scotland \(nls.uk\)](#) – Accessed December 2023

<sup>2</sup> [Earth Versions – Google Earth](#) – accessed December 2023

<sup>3</sup> [GeoIndex \(onshore\) - British Geological Survey \(bgs.ac.uk\)](#) – Accessed December 2023

<sup>4</sup> British Geological Survey (2011). 1:63,360/1:50,000 geological map series, sheet number 250, solid and drift. Chepstow.

<sup>5</sup> Geology of the country around Monmouth and Chepstow: Explanation of sheets 233 and 250. 1961 – Accessed December 2023

<sup>6</sup> British Geological Survey (2023). Lexicon of Named Rock Units (<https://www.bgs.ac.uk/Lexicon/>).

<sup>7</sup> [Interactive Map Viewer | Coal Authority \(bgs.ac.uk\)](#) – Accessed December 2023

## 2.6 Hydrology and hydrogeology

Long term flood risk for the site has been obtained from Natural Resource Wales (NRW) Flood Maps<sup>8</sup> for the scheme area. Flood risk is discussed in Section 4.8 of this report.

Hydrogeology has been reviewed using the BGS GeoIndex<sup>3</sup> viewer.

## 2.7 Unexploded Ordnance

A preliminary UXO threat assessment for the site has been made using the Zetica UXO<sup>9</sup> online mapping.

## 2.8 Radon

UK Health Security Agency's (UKHSA) interactive radon map<sup>10</sup> and Groundsure Report were reviewed as part of this scheme to assess radon risk at the site and in the surrounding area.

---

<sup>8</sup> [Flood and Coastal Erosion Risk Maps \(naturalresources.wales\)](#) – Accessed December 2023

<sup>9</sup> [Risk Maps | Zetica UXO](#) – Accessed December 2023

<sup>10</sup> [UKradon - UK maps of radon](#) – Accessed December 2023

### 3 Site Description

#### 3.1 General

The site is a green space comprising open grassland centred at UK National Grid Reference ST 42182 87741. It is approximately 270m north-west to south-east and 280m east to west. The site has a perimeter of 790m and an approximate area of 2.81 hectares.

The site is bounded by the M4 motorway to the north, St Bride’s Road to the north-east and residential buildings within Magor village to the south-east. It is bounded by grassland to the east, west and south-west. The location of the site both regionally and locally is shown in Figure 3.1 and Figure 3.2

Figure 3.1: Regional site location plan



Source: Mott MacDonald/ArcGIS, 2023

**Figure 3.2: Local site location plan**



Source: Mott MacDonald/ArcGIS, 2023

### 3.2 Topography

The topography of the site has been assessed from Google Earth<sup>2</sup> and verified by a site visit on the 12<sup>th</sup> of January 2024. The overall site slopes gently towards the south-east and, according to Google Earth, lies between 14m and 23m Above Ordnance Datum (mAOD) with the lowest part of the site being located along the eastern edge of the site, adjacent to St Brides Road.

### 3.3 Geomorphology

BGS 1:50,000 geological map Sheet 250 Chepstow does not indicate any geomorphological features on site.

### 3.4 Historic development and current land use

A review of the historical development of the site has been undertaken using historical and current Ordnance Survey (OS) mapping, Groundsure reporting, and historical aerial imagery, the results of which are presented in Table 3.1.

**Table 3.1: Historical development and current land use of the site and surrounding area.**

Map Date (Scale)	On-site	Off-site
1879 (1:2,500)	The site comprises an undeveloped open field	The surrounding area is generally undeveloped comprising a series of open fields. The village of Magor can be seen to the south-east of the site.  A vicarage is present approximately 100m south-west of the site, next to areas labelled "Old quarries" and "Old limekiln".



Map Date (Scale)	On-site	Off-site
		The Mill Reen can be seen running north to south approximately 160m east of site.
1880 – 1881 (1:10,560)	No significant change	<p>A quarry can be seen approximately 200m south-west of the site.</p> <p>The larger scale shows two farms in Magor village south-east of the site. Tithe farm is located approximately 320m south-east of the site, and Magor farm is located approximately 450m south-east of the site.</p> <p>There is also a mill pond located approximately 460m south-east of the site.</p> <p>A limekiln and quarry can be seen approximately 460m north-west of the site.</p>
1900 (1:2,500)	No significant change	The limekiln and quarry 460m north-west of site are now labelled “Old limekiln” and “Old quarry”.
1900 (1:10,560)	No significant change	<p>Several quarries are located approximately 460m east-south-east of site, around the location labelled Quarry Rise on present day mapping.</p> <p>The quarry located approximately 200m south-west of site is now labelled “Old Quarry”.</p> <p>An “Old Quay” can be seen approximately 500m south-east of site.</p>
1883-1913 (1:10,560)	No significant change	Mill pond 460m south-east of the site is no longer labelled.
1919 (1:2,500)	No significant change	Langley villa can be seen approximately 35m east of site.
1918 – 1919 (1:10,560)	No significant change	<p>The Beeches and The Cedars buildings are now located approximately 490m north-east of site. These appear to be linked to farmland.</p> <p>A school can be seen approximately 470m south-east of site.</p> <p>There is a well located approximately 480m east of site.</p>
1949 (1:10,560)	No significant change	No significant change
Pre-1930 - 1963 (1:10,560)	No significant change	New streets can be seen adjacent to the south-eastern edge of the site.
1966 -1970 (1:10,560) 1966 – 1967 (1:2,500)	No significant change	<p>The M4 motorway has been constructed immediately to the north of the site running in a broadly east to west orientation. This road is indicated as being on embankment, with an off-slip shown, approaching an interchange which is located to the north-west of the site.</p> <p>Newport Road (B4245) can be seen approximately 110m south of site.</p> <p>Magor village has extended to the south-eastern edge of the site and domestic buildings and streets can now be seen abutting the south-east boundary of the site.</p>
1988 (1:10,000)	No significant change	<p>Magor village has expanded further.</p> <p>A police station is located 240m west of the site.</p> <p>A depot can be seen 250m south-west of the site.</p> <p>There is a brewery located approximately 380m west-south-west of the site.</p> <p>The Beeches farm caravan park is located approximately 470m north-east of site.</p>
2001 (1:10,000)	No significant change	A service area is labelled approximately 115m north of site.
2010 (1:10,000)	No significant change	No significant change.
2023 (1:10,000)	No significant change	The police station 240m west of site is no longer labelled.
2023 (aerial imagery)	No significant change	A car park can be seen 125m north of the site.

Map Date (Scale)	On-site	Off-site
		<p>BP petrol station is located approximately 145m north of the site.</p> <p>Monmouthshire County Council can be seen approximately 170m west of the site.</p> <p>Old Tythe Garages can be seen approximately 335m south-east of the site. A news report from the South Wales Argus<sup>11</sup> indicates that the garage was closed in October after 43 years of operation. The report also indicates that the site was used as a piggery prior to its use as a garage.</p> <p>The brewery 380m west-south-west of the site is now called AB InBev UK Ltd Brewery.</p> <p>Beeches taxis of Magor, a taxi service company is situated on the site of The Beeches, approximately 490m north-east of site.</p>

### 3.5 Unexploded Ordnance

The Zetica Risk Map shows that the site is located within a Low Risk area defined as an area having '15 bombs per 1000 acres or less'. The area within 1.0km of the site is also classified as Low Risk and the closest target is labelled as a 'bombing decoy' and is situated at an approximate distance of 3.0km from the site centre.

### 3.6 Other information

#### 3.6.1 Radon hazards

According to the Groundsure Report, the highest band of radon risk on site is 3-5%, indicating that there is a 3-5% likelihood of any building on site exceeding Radon Action Level of 200Bq/m<sup>3</sup>. As the proposed development is not expected to comprise any below ground structures or significant enclosed and unventilated spaces, the risk from radon is considered to be low. However, due to the brick-and-mortar utility blocks, it is recommended that a Radon Search Address Report is obtained to determine the exact Radon Potential of the site, and appropriate protection put into place based on the results.

Should the proposed development change however this risk should be reassessed.

#### 3.6.2 Services and Utilities

At the time of writing this report, Mott MacDonald has not been provided with any service or utility plans for the site. Given the undeveloped nature of the site, it is considered unlikely that significant buried services are present beneath the site. However, it should be noted that an animal water trough and alkathene supply pipe for connection to the water supply were identified during the site walkover as detailed in Section 3.7.

#### 3.6.3 Regulatory Information

Information on the site and surrounding area's land use, pollution incidents, and designations is presented in Table 3.2.

**Table 3.2: Land use, Designated Sites and Pollution Incidents**

Aspect	Detail
<b>Agency and Hydrological</b>	

<sup>11</sup> [Garage in Magor to close after 43 years as owners retire in October | South Wales Argus](#) – Accessed January 2024

Aspect	Detail
<b>Discharge Consents</b>	There are no discharge consents associated with the site. There are a total of four discharge consents within 244m of the site. Only one of these is currently active, at a location 156m west of the site. It permits the discharge of sewage (non-water company sewer storm overflow) from Magor Motorway Services into St Brides Brook.
<b>Local Authority Pollution Prevention Controls</b>	There are no local authority Pollution Prevention and Controls permits within the site, however there is one recorded 145m north-west of site, associated with the petrol station.
<b>Pollution Incidents</b>	There are no pollution incidents associated with the site however there are two recorded pollution incidents within 500m of the site.  The closest occurred 47m south of the site in 2001 from an unidentified pollutant, however this was recorded as having no impact on either land, water or air.  The second incident is linked to organic chemical pollutants and occurred in 2015, 141m north-west of the site, likely associated with the petrol filling station and was recorded as having no impact on either land or air. There is no recorded impact to water however as the incident occurred over 8 years ago the likelihood of any significant impact to the site still being present is considered to be low.
<b>Waste</b>	
<b>Registered Landfill Sites</b>	There are no registered landfills on site. There is one historical landfill located within 500m of the site. It is located 407m east of the site at Land off Dancing Hill and is recorded as accepting inert and household waste.
<b>Waste Sites</b>	There are no records of any waste activities being carried out on or within 500m of the site.
<b>Waste exemptions</b>	There are four waste exemptions recorded within 500m of the site. These are all registered for a depot located 129m south of site and relate to the storage of waste in a secure place and the use of waste in construction.
<b>Potentially Infilled Land (Non-Water)</b>	There are no records of infilled land on, or within 500m of the site.
<b>Hazardous Substances</b>	
<b>Control of Major Accident Hazards Sites (COMAH)</b>	There are no recorded COMAH sites on, or within 500m of the site.
<b>Planning Hazardous Substance Consents</b>	There are no recorded Hazardous Substance Consents on, or within 500m of the site.
<b>Historic Land Uses</b>	
<b>Industrial land uses</b>	There are no recorded historical industrial land uses registered for the site. There are 17 located within 500m of the site with the nearest being located 17m to the north-west and comprising 'cuttings', likely associated with the construction of the M4.
<b>Energy Features</b>	There are no energy features recorded on the site. There are six energy features recorded within 500m of the site, predominantly electrical substations and gas governor stations. The closest energy feature is an electrical substation located 94m to the south-east.
<b>Petrol Stations and garages</b>	There are five historical garages recorded within 500m of the site with the nearest being 59m to the north-east. However, of the five garages recorded three are likely to be the same location being registered multiple times as they are all located between 307 and 308m to the south-east of the site.
<b>Storage tanks</b>	There are no records of storage tanks on the site. Three tanks are recorded within 500m of the site, the closest being 407m the west.
<b>Military Land</b>	There are no records of military land on, or within 500m of the site.
<b>Current Industrial Land Uses</b>	
<b>Industrial land uses</b>	There are no records of current industrial land use for the site. The nearest industrial land use is the AB InBev UK Ltd Brewery located 380m west-south-west of the site.

Aspect	Detail
<b>Petrol Stations</b>	There are no records of current or recent petrol stations on site. There is one petrol station within 500m of the site, located 144m to the north-west.
<b>Electricity Cables</b>	There are no records of underground high voltage electricity transmission cables on or within 500m of the site.
<b>Gas Pipelines</b>	There are no records of underground high-pressure gas main on or within 500m of the site.
<b>Contaminated Land</b>	There are no records of land requiring remediation under Part 2a of the Environmental Protection Act 1990 on, or within 500m of the site.
<b>Regulated explosive sites</b>	There are no records of sites registered and licensed to manufacture and store explosives on or within 500m of the site.
<b>Radioactive substances</b>	There are no records of the use or storage of radioactive substances on, or within 500m of the site.
<b>Hazardous Substances</b>	There are no records of sites licensed to store hazardous substances on or within 500m of the site.
<b>Sensitive Land Use</b>	
<b>Ancient Woodland</b>	There are no registered ancient woodlands recorded on site. The nearest such area is located 810m north-east of the site.
<b>Local Nature Reserves</b>	There are no local nature reserves within 500m of the site.
<b>Listed buildings</b>	The Vicarage, a Grade II listed building, is situated 111m south-west of the site.
<b>World Heritage Sites</b>	There are no world heritage sites recorded on or within 500m of the site.

### 3.7 Site Reconnaissance

A walkover of the site was carried out on the 12<sup>th</sup> of January 2024 during which the weather was cool and dry. The following observations were made:

- Access to the site was via a metal gate located at the eastern edge of the site, off St Bride's Road.
- The soil on site is predominantly thick mud which is soft underfoot and covered in greenery which consists of turnips planted by the current tenants, and close-grazed grass.
- A shallow gradient towards the south-east was observed during the walkover. However, a bund sloping towards the south-west can be observed in the eastern section of the site as seen in Photo C.4.
- The site boundary mainly comprises wooden post and rail fencing in good condition, with a wire stock fence also attached.
- Hedges and battery-powered wire stock fences separate the site into three fields.
- Present site use is agricultural, with livestock including cattle, sheep and horses being housed on site.
- Based on discussion with the current tenants, the site previously consisted of overgrown brush which was cleared out when the tenants took over the property about three years ago.
- A metal caravan was situated near the eastern edge of the site with some wooden boards placed next to it.
- A water trough for cattle use was located at a grid reference of ST 42192 87746, near the site centre. A single alkathene pipe connects the trough to a water supply near the site entrance off St Bride's Road.
- Discussion with the current tenants indicates that some redundant water pipes from prior site use may be present at the site.
- There are no overhead lines, or any other services observed on site.

Based on the above observations, no specific sources of contamination were identified. A photographic record from the walkover can be found in Appendix C.

## 4 Ground Conditions

### 4.1 Topsoil

Given the undeveloped nature of the site, and the lack of known historical developments within the site boundary, it is likely that topsoil is present across the whole site area.

### 4.2 Artificial Ground

Made Ground has not been mapped on or in close proximity to the site. Given the current and historical land uses of the site, significant thicknesses of Made Ground at the site are not anticipated. However, localised Made Ground may be present along the northern and south-eastern boundaries associated with the construction of the M4 motorway and the adjacent residential areas respectively.

### 4.3 Superficial Deposits

The BGS GeoIndex<sup>3</sup> indicates that the site is underlain by River Terrace Deposits, consisting of sand and gravel. Specifically, the deposits present on site are identified as Third-Second Terrace towards the eastern part of the site and Second Terrace towards western part of the site.

According to the BGS memoir for Monmouth<sup>5</sup>, the age of River Terrace Deposits can be determined by their height, with terraces at higher levels *'considered to be older than those nearer to the flood plain.'* The memoir describes the Third-Second Terrace as a *'spread of gravelly material which cannot be definitively assigned to either one of the [Third or Second] terraces.'* The Third Terrace deposit is described as occurring at an average level of 100ft (30.48m) AOD, and the Second Terrace deposit occurs at an average level of 50ft (15.24m) AOD.

### 4.4 Bedrock Geology

The BGS GeoIndex<sup>3</sup> shows that the site is underlain by strata of the Mercia Mudstone Group (Marginal Facies) in the northern part of the site and limestone of the Avon Group in the southern part of the site.

The Mercia Mudstone Group (Marginal Facies) is described by the BGS Lexicon<sup>6</sup> as consisting of *'conglomerate and/or breccia with clasts derived locally from rocks lying immediately below the unconformable base of these deposits'* formed during the Triassic Period. The lexicon also highlights that the matrix is typically made up of *'finer-grained rock fragments or, less commonly, siltstone, sandstone or micritic limestone.'*

The BGS Lexicon<sup>6</sup> describes the Avon Group as *'Interbedded grey mudstones and thin- to medium-bedded skeletal packstones with one to several thick units of ooidal and skeletal grainstones'* formed during the Courceyan Substage. It also consists of thin units of calcite mudstone, locally present mudstone, and sparse thin ironstones.

### 4.5 Land Mass Movement

GeoIndex<sup>3</sup> does not record any land mass movement events on site with no mass movement deposits within 500m.

## 4.6 Mining and Quarrying

### 4.6.1 Coal Mining

The Coal Authority Interactive Map Viewer<sup>7</sup> indicates that there is no Coal Mining Reporting Area located on site or within 500m of the site.

### 4.6.2 Non-coal Mining

The Groundsure report indicates that there are no known non-coal mining features on site. However, the following non-coal mining features have been recorded within 500m of the site:

- Seven ‘BritPits’, all described as ‘surface mineral working, sometimes termed a quarry, sand pit, clay pit, or opencast coal site’. The status of all BritPits is described as “ceased”, with the closest being a limestone BritPit located 136m to the west at The Elms.
- 22 surface ground workings the closest of which is located 17m to the north-west and described as a ‘cutting’.

## 4.7 BGS Ground Stability Hazards

Potential BGS Ground Stability Hazards highlighted within the Groundsure Report are presented in Table 4.1.

**Table 4.1: BGS Ground Stability Hazards**

Ground Stability Hazard	Hazard Potential on Site
Collapsible Ground	Very Low
Compressible Ground	Negligible
Ground Dissolution	Moderate
Landslides	Very Low
Running Sands	Very Low
Shrinking or Swelling Clay	Negligible

## 4.8 Hydrology and Flooding

The nearest watercourse is Mill Reen (known as St Bride’s Brook, north of the M4) which is located approximately 150m east of the site and flows to the south before ultimately discharging into the Severn Estuary. DataMap Wales<sup>12</sup> designates the Mill Reen as a Main River (Water Body ID: GB109056026860).

There is one other surface water feature located within 500m of the site. A minor, unnamed watercourse described in the Groundsure report as an ‘inland river not influenced by normal tidal action’ is located 110m south-east of the site. This likely comprises a land drain or similar.

The Water Watch Wales Map<sup>13</sup> by Natural Resources Wales classifies the Mill Reen with a “good” chemical rating and “moderate” ecological rating, with an overall status of “moderate” based on 2016 data.

The Groundsure report indicates that the site is not at risk from floods associated with the nearby rivers. However, there is a low risk of flooding within 50m east and north-east of the site, likely associated with the Mill Reen/St Bride’s Brook. The Groundsure report indicates that there

<sup>12</sup> Home | DataMapWales (gov.wales) – Accessed December 2023

<sup>13</sup> Water Watch Wales (naturalresourceswales.gov.uk) – Accessed December 2023

is no history of flooding within 250m of the site, however a news report from Wales Online<sup>14</sup> highlights a flooding incident associated with the Mill Reen which took place in December 2020.

The Groundsure Report indicates a low-moderate risk of groundwater flooding on site.

## 4.9 Hydrogeology

The superficial deposits underlying the site are categorised as a Secondary A aquifer. This is described by the BGS as *‘Permeable layers capable of supporting water supplies at a local rather than strategic scale, and in some cases forming an important source of base flow to rivers. These are generally aquifers formerly classified as minor aquifers’*.

The bedrock geology underlying the site is classified as a Principal aquifer, which is described by the BGS as *‘Geology of high intergranular and/or fracture permeability, usually providing a high level of water storage and may support water supply/river base flow on a strategic scale’*.

According to the Groundsure Report, the superficial aquifer is designated as being of “medium vulnerability”. The bedrock aquifer is classified as a “high vulnerability” aquifer, defined as *‘Areas able to easily transmit pollution to groundwater. They are likely to be characterised by high leaching soils and the absence of low permeability superficial deposits’*.

The Water Watch Wales Map<sup>13</sup> by Natural Resources Wales classifies the groundwater under the site, named Usk and Wye Southern Carboniferous Limestone, as being a “good” chemical rating and an overall status of “good” based on 2017 data.

The site does not lie within a Source Protection Zone and there are no known groundwater or surface water abstractions on site or within 500m of the site.

## 4.10 Historical Ground Investigations

Mott MacDonald is not aware of any historical ground investigations having been carried out within the site boundaries.

### 4.10.1 BGS Borehole Records

There is one BGS borehole recorded within the site extent. 25 exploratory holes were also recorded within 250m of the site, 15 of these within 150m of the site.

A summary of relevant BGS boreholes located within approximately 125m of the site is presented below in Table 4.2, and copies of the logs are provided in Appendix B. It is worth noting that some logs were taken in imperial units but have been converted to metric units for this report.

**Table 4.2: Summary of BGS Borehole Records**

BGS Reference	Name	Year	Depth (m)	Approximate Distance (m) and Direction	Easting	Northing
ST48NW82	LONDON-SOUTH WALES MOTORWAY 65	1962	7.62	On site	342326	187782
ST48NW28	2ND SEVERN CROSSING 7108	1990	10.00	10m east	342353	187773
ST48NW81	LONDON-SOUTH WALES MOTORWAY 64	1962	3.04	21m north-west	342094	187835

<sup>14</sup> [Homeowners still living upstairs in flood-damaged houses 11 months after Christmas Eve storm - Wales Online](#) – Accessed December 2023



BGS Reference	Name	Year	Depth (m)	Approximate Distance (m) and Direction	Easting	Northing
ST48NW29	2ND SEVERN CROSSING 7109	1990	9.80	48m north-east	342341	187829
ST48NW92	LONDON-SOUTH WALES MOTORWAY 108	1962	4.26	86m east	342430	187770
ST48NW93	LONDON-SOUTH WALES MOTORWAY 109	1962	3.35	94m east	342438	187771
ST48NW84	LONDON-SOUTH WALES MOTORWAY 66A	1962	7.62	99m east	342443	187770
ST48NW79	LONDON-SOUTH WALES MOTORWAY 61	1962	6.09	105m north-west	341996	187885
ST48NW53	M4 SECOND SEVERN CROSSING, MAIN ONSHORE GI TP 7411	1990	4.70	106m east	342452	187740
ST48NW94	LONDON-SOUTH WALES MOTORWAY 110	1962	3.20	106m east	342450	187769
ST48NW52	M4 SECOND SEVERN CROSSING, MAIN ONSHORE GI TP7412	1990	1.70	109m east	342454	187753
ST48NW80	LONDON-SOUTH WALES MOTORWAY 62	1962	4.64	110m north-west	341962	187855
ST48NW83	LONDON-SOUTH WALES MOTORWAY 66	1962	9.14	114m east	342444	187823
ST48NW95	LONDON-SOUTH WALES MOTORWAY 111	1962	4.26	116m east	342460	187774
ST48NW97	LONDON-SOUTH WALES MOTORWAY 113	1962	3.20	121m east	342465	187767
ST48NW96	LONDON-SOUTH WALES MOTORWAY 112	1962	3.35	127m east	342471	187767

The on-site historical borehole (ST48NW82) is located in the north-eastern edge of the site and is described as 16ft and 6 inches (5.03m) of firm red-brown sandy silty CLAY over 8ft and 6 inches (2.59m) of compact sand and gravel.

The other BGS boreholes within 500m of the site indicate that the ground conditions within the wider area generally comprise topsoil of thicknesses between 0.00m to 0.30m, underlain by superficial deposits comprising firm red-brown silty sandy clay, sands, gravels, clays, and limestone or limestone fragments. Probable bedrock was encountered one borehole (ST48NW29) at a depth of 9m below ground level.

It is worth noting that none of the boreholes within 150m of the site occurs in the southern section of the site and hence, there is no historical information on the possibility of Avon Group bedrock obtained from the BGS borehole records.

#### 4.11 Ground Gas Generation Potential

Based on the available information it is not considered likely that the soils underlying the site have the potential to produce significant concentrations or quantities of ground gas that could pose a risk the sites end users. As such the risk from ground gas is not considered further.

Should significant deposits of organic materials, whether natural or anthropogenic in nature, be encountered during any future development work this assumption should be reconsidered.

## 5 Preliminary Ground Model

### 5.1 Ground Model

The historical site information and BGS GeoIndex<sup>3</sup> have been used to infer the potential ground conditions beneath the site; a preliminary ground model is presented in Table 5.1.

**Table 5.1: Preliminary Ground Model**

Strata	Depth to Top (m)	Anticipated Thickness (m)	Typical Description
Topsoil	0.00	0.00 – 0.30	Anticipated to comprise brown sands, silts and clays with minor gravel content and rootlets.
River Terrace Deposits	0.00	0.00 – 9.00	Red-brown silty, sandy clay with some sand, gravels, and limestone fragments
Mercia Mudstone Group (Marginal Facies)	9.00	9.00 – Base unproven	Anticipated to be stiff red marl with some limestone and sandstone
Avon Group	N/A	Unproven	Anticipated to be grey mudstones, thin to medium-bedded packstones and some units of skeletal grainstones

Note: Depths have been assumed, based on nearby BGS boreholes, and as such may not accurately represent the conditions beneath the site.

### 5.2 Groundwater

There is no current information available to inform the groundwater conditions beneath the site area. Groundwater was not found in any of the boreholes detailed in Section 4.10.1.

Groundwater, if encountered would be expected to be flowing towards the south towards the Severn Estuary and east towards the Mill Reen.

### 5.3 Obstructions

Natural obstructions, such as cobbles or boulders, may be present within the River Terrace Deposits and Mercia Mudstone bedrock.

Buried water pipes associated with the animal water troughs are known to be present beneath the site, the line of which is currently unknown.

## 6 Preliminary Contamination Risk Assessment

### 6.1 Preliminary Conceptual Model Methodology

Historical contaminated land is managed in the UK through Part 2A of the Environmental Protection Act (EPA) 1990<sup>15</sup> or, where development of a site is to take place, through the Town and Country Planning Act 1990<sup>16</sup>. The Town and Country Planning Act requires that a site must be suitable for its intended use and that there are no significant risks to the environment following development. A developed site must be left in a condition that it cannot be determined as “contaminated land” under Part 2A.

This report adopts a strategy for the assessment of potential land contamination based on current government guidance contained in Land Contamination Risk Management (LCRM)<sup>17</sup> and CIRIA Report C552<sup>18</sup>.

A key element in the risk assessment for land contamination is the development of a Conceptual Site Model (CSM) which may be refined or revised as more information and understanding is obtained through the risk assessment process. The CSM is described in terms of the contaminant ‘Source’, transport ‘Pathways’ and possible ‘Receptors’ that may be present. These are defined as:

- Sources (S) are potential or known contaminant sources e.g. arisings from a former land use.
- Pathways (P) are environmental systems through which a contaminant could migrate e.g. air, groundwater or direct contact; and
- Receptors (R) are sensitive environmental or human receptors that could be adversely affected by a contaminant e.g. site occupiers, groundwater resources.

Where a source, relevant pathway and receptor are present, a contaminant linkage is present which requires further investigation and risk assessment.

The conceptual model and qualitative risk assessment are presented in Table 6.1. The risk assessment process is described in Section 6.2.

It is anticipated that, as part of any future ground investigation works, geo-environmental laboratory testing will be undertaken on samples of soil, rock and water recovered during an intrusive ground investigation, to inform further development of the potential risks at the site.

### 6.2 Preliminary Risk Assessment Methodology

For each potential contaminant linkage identified within the conceptual model presented in this report, the potential risk has been evaluated for ecological receptors, buildings and construction/maintenance workers and the final end users. A Preliminary Qualitative Risk Assessment has been prepared, based on the probability of the pollution event, and the severity

---

<sup>15</sup> Environmental Protection Act 1990 ([legislation.gov.uk](https://legislation.gov.uk)) – Accessed February 2024

<sup>16</sup> Town and Country Planning Act 1990 ([legislation.gov.uk](https://legislation.gov.uk)) – Accessed February 2024

<sup>17</sup> Land contamination risk management (LCRM) - GOV.UK ([www.gov.uk](https://www.gov.uk)) – Accessed February 2024

<sup>18</sup> CIRIA (2001). Contaminated land risk assessment. A guide to good practice (C552) – Accessed February 2024

it may have on site users and the environment. R&D Publication 66<sup>19</sup> sets out the classification used in the Preliminary Qualitative Risk Assessment. The classification has been developed from DOE Guide to Risk Assessment and Risk Management for Environmental Protection<sup>20</sup> and the Contaminated Land Statutory Guidance<sup>21</sup>. The key to the classification is that the designation of risk is based upon the consideration of both:

- The magnitude of the potential consequence (i.e. severity); and
  - Takes into account both the potential severity of the hazard and the sensitivity of the receptor
- The magnitude of probability (i.e. likelihood)

**Table 6.1: Classification of consequence**

Classification	Definition of Consequence
Severe	Highly elevated concentrations likely to result in 'significant harm' to human health as defined by the EPA 1990, Part 2A, if exposure occurs. Equivalent to EA Category 1 pollution incident including persistent and/or extensive effects on water quality; leading to closure of a potable abstraction point; major impact on amenity value or major damage to agriculture or commerce. Major damage to aquatic or other ecosystems, which is likely to result in a substantial adverse change in its functioning or harm to a species of special interest that endangers the long - term maintenance of the population. Catastrophic damage to crops, buildings or property.
Medium	Elevated concentrations which could result in 'significant harm' to human health as defined by the EPA 1990, Part 2A if exposure occurs. Equivalent to EA Category 2 pollution incident including significant effect on water quality; notification required to abstractors; reduction in amenity value or significant damage to agriculture or commerce. Significant damage to aquatic or other ecosystems, which may result in a substantial adverse change in its functioning or harm to a species of special interest that may endanger the long - term maintenance of the population. Significant damage to crops, buildings or property.
Mild	Exposure to human health unlikely to lead to 'significant harm'. Equivalent to EA Category 3 pollution incident including minimal or short-lived effect on water quality; marginal effect on amenity value, agriculture or commerce. Minor or short-lived damage to aquatic or other ecosystems, which is unlikely to result in a substantial adverse change in its functioning or harm to a species of special interest that would endanger the long - term maintenance of the population. Minor damage to crops, buildings or property.
Minor	No measurable effect on humans. Equivalent to insubstantial pollution incident with no observed effect on water quality or ecosystems. Repairable effects of damage to buildings, structures, and services.

The probability of contamination risks occurring is classified in accordance with Table 6.2. A contaminant linkage must first be established before probability is classified. If there is no contaminant linkage, then there is no potential risk and therefore no requirement to apply tests for probability and consequence.

**Table 6.2: Classification of probability**

Classification	Definition
High Likelihood	There is contaminant linkage and an event would appear very likely in the short - term and almost inevitable over the long - term, or there is evidence at the receptor of harm or pollution.
Likely	There is contaminant linkage and all the elements are present and in the right place which means that it is probable that an event will occur. Circumstances are such that an event is not inevitable, but possible in the short - term and likely over the long - term.

<sup>19</sup> R&D66 VOL 1 Guidance for the Safe Development of Housing on Land Affected by Contamination ([nhbc.co.uk](http://nhbc.co.uk)) – Accessed February 2024

<sup>20</sup> Department of the Environment (1995). Guide to Risk Assessment and Risk Management for Environmental Protection.

<sup>21</sup> Contaminated Land Statutory Guidance – 2012 ([gov.wales](http://gov.wales)) – Accessed February 2024

Classification	Definition
Low Likelihood	There is contaminant linkage and circumstances are possible under which an event could occur. However, it is by no means certain that even over a long period such an event would take place and is less likely in the shorter term.
Unlikely	There is contaminant linkage, but circumstances are such that it is improbable that an event would occur even in the very long - term.

For each possible contaminant linkage identified, the potential risk can be evaluated based upon the following probability x consequence matrix shown in Table 6.3.

**Table 6.3: Overall Contamination Risk Matrix**

		Consequence			
		Severe	Medium	Mild	Minor
Probability	High Likelihood	Very high risk	High risk	Moderate risk	Moderate / low risk
	Likely	High risk	Moderate risk	Moderate / low risk	Low risk
	Low Likelihood	Moderate risk	Moderate / low risk	Low risk	Very low risk
	Unlikely	Moderate / low risk	Low risk	Very low risk	Very low risk

R&D 66:2008 presents definitions of the risk categories, together with the investigatory and remedial actions that are likely to be necessary in each case. These definitions are reproduced in Table 6.4. These risk categories apply to each contaminant linkage, not simply to each hazard or receptor.

**Table 6.4: Definition of Risk Categories and Likely Action Required**

Risk Category	Definition and Likely Actions
Very high	There is a high probability that severe harm could arise to a designated receptor from an identified hazard at the site without remediation action OR there is evidence that severe harm to a designated receptor is already occurring. Realisation of that risk is likely to present a substantial liability to be site owner/or occupier. Investigation is required as a matter of urgency and remediation works likely to follow in the short - term.
High	Harm is likely to arise to a designated receptor from an identified hazard at the site without remediation action. Realisation of the risk is likely to present a substantial liability to the site owner/or occupier. Investigation is required as a matter of urgency to clarify the risk. Remediation works may be necessary in the short - term and are likely over the longer term.
Moderate	It is possible that harm could arise to a designated receptor from an identified hazard. However, it is either relatively unlikely that any such harm would be severe, and if any harm were to occur it is more likely, that the harm would be relatively mild. Further investigative work is normally required to clarify the risk and to determine the potential liability to site owner/occupier. Some remediation works may be required in the longer term.
Low	It is possible that harm could arise to a designated receptor from identified hazard, but it is likely at worst, that this harm if realised would normally be mild. It is unlikely that the site owner/or occupier would face substantial liabilities from such a risk. Further investigative work (which is likely to be limited) to clarify the risk may be required. Any subsequent remediation works are likely to be relatively limited.
Very low	It is a low possibility that harm could arise to a designated receptor, but it is likely at worst, that this harm if realised would normally be mild or minor.

### 6.3 Preliminary Conceptual Site Model

The following sources, pathways and receptors have been considered based on the available information for this site.

### **Potential Sources**

**S1:** Sources associated with historical and current site use as an undeveloped field, including potential localised Made Ground from the construction of the M4 and adjacent residential areas.

**S2:** Sources associated with off-site activities upstream and up the anticipated groundwater gradient (including infilled quarries, BP petrol station, breweries and the M48)

### **Potential Pathways**

**P1:** Human uptake pathways including ingestion, inhalation, and direct contact.

**P2:** Man-made pathways – e.g., excavations, buried foundations.

**P3:** Vertical and horizontal migration of contaminants in the subsurface.

**P4:** Overland flow - surface runoff.

### **Potential Receptors**

**R1:** Human receptors – site end users.

**R2:** Construction and maintenance workers.

**R3:** Groundwater – Superficial Secondary A Aquifer and Bedrock Principal Aquifer.

**R4:** Environmental receptors – including the Mill Reen.

**Table 6.5: Conceptual Site Model**

Potential Sources	Potential Pathways	Potential Receptors	Consequence	Likelihood	Risk Classification
<b>S1:</b> Sources associated with historical and current site use	<b>P1:</b> Human uptake pathways	<b>R1:</b> Site end users	<b>Mild</b> – as the site has remained undeveloped, it is not expected that contaminants of consequence will be encountered on site. Localised Made Ground may be present but is not expected to occur in significant amounts.	<b>Unlikely</b> – There is no current evidence that significant contaminant sources exist, and the site will have a transient population so the likelihood of residents growing produce on site is low. Extent of Made Ground is expected to be highly limited in extent.	<b>Very Low</b>
	<b>P1:</b> Human uptake pathways <b>P2:</b> Man-made pathways	<b>R2:</b> Construction and maintenance workers		<b>Low likelihood</b> – It is possible that construction and maintenance may come into contact with any contaminants in on-site soil during works. However, as the proposed works are limited to the shallow sub surface, the likelihood is low. This likelihood will be mitigated by contractors employing safe and appropriate systems of work.	<b>Low</b>
	<b>P3:</b> Vertical and horizontal migration in the sub surface	<b>R3:</b> Groundwater – Superficial Secondary A Aquifer and Bedrock Principal Aquifer		<b>Unlikely</b> – There is no evidence of significant contamination on site and if present, they are not expected to be sufficiently leachable as to become mobile.	<b>Very Low</b>
	<b>P4:</b> Overland flow - surface runoff	<b>R4:</b> Environmental receptors – including the Mill Reen		<b>Unlikely</b> – There is no evidence of significant contamination on site and if present, they are not expected to be sufficiently leachable as to become mobile.	<b>Very Low</b>
<b>S2:</b> Sources associated with historical and current off-site activities	<b>P1:</b> Human uptake pathways	<b>R1:</b> Site end users	<b>Mild</b> – contaminants associated with off-site activity including hydrocarbons and associated with the petrol station and other chemical compounds associated with the brewery could cause significant harm to human health and the environment. However, it is unlikely that such contaminants will be present in sufficient concentrations due to the distances involved between the site and off-site sources.	<b>Low likelihood</b> – There is a possibility that site end users come into contact with contaminants associated with off-site industry, including airborne emissions from the M48.	<b>Low</b>
	<b>P1:</b> Human uptake pathways <b>P2:</b> Man-made pathways	<b>R2:</b> Construction and maintenance workers		<b>Unlikely</b> – Due to the nature of works, it is possible that contractors may come into contact with contaminants associated with off-site activities. However, there is currently no evidence of such contamination and as the proposed works are limited to the shallow sub surface, the likelihood is low. This risk will be further mitigated by contractors employing safe and appropriate systems of work.	<b>Very Low</b>
	<b>P3:</b> Vertical and horizontal migration of contaminants in the subsurface	<b>R3:</b> Groundwater – Superficial Secondary A Aquifer and Bedrock Principal Aquifer		<b>Unlikely</b> – There is currently no evidence of sub-surface contamination associated with off-site industry and if present, they are not expected to become sufficiently mobile to migrate below the site.	<b>Very Low</b>

## 7 Conclusions

Mott MacDonald has been commissioned by Monmouthshire County Council to produce a Phase I Desk Study for the proposed development of a new travellers' camp at Magor.

The following conclusions are based on the understanding that the proposed development comprises the construction of a service block containing toilets, showers, cooking and laundry facilities, with access roads to a number of pitches.

It is recommended that this desk study be updated should the scheme proposals be refined or changed.

### 7.1 Ground Conditions

The ground conditions anticipated to underlie the site have been inferred from available geological mapping and supplemented by the findings from historical off site BGS exploratory holes. A preliminary ground model has been developed for the site. The conditions underlying the site are anticipated to comprise the following:

- Topsoil: Anticipated to comprise brown sands silts and clays with minor gravel inclusions present beneath the whole site area.
- Possible localised Made Ground: May be present locally within the site associated with adjacent development of the M4 and residential development.
- River Terrace Deposits: Anticipated to comprise red-brown silty, sandy clay with some sand, gravels, and limestone fragments.
- Mercia Mudstone Group (Bedrock): Anticipated to be stiff red marl with some limestone and sandstone.
- Avon Group (Bedrock): Anticipated to be grey mudstones, thin to medium-bedded packstones and some units of skeletal grainstones.
- Groundwater levels beneath the site are currently unknown.

#### 7.1.1 Geo-environmental

A preliminary contaminated land risk assessment has been developed for the site to identify potential contaminant linkages associated with the proposed development.

##### 7.1.1.1 Human Health

It is not considered likely that the ground conditions on site pose a significant risk to the health of site end users or construction workers. Should soils be identified on site during the works that are not consistent with the likely ground conditions described within this report, works should stop and samples of the suspect materials should be recovered and sent for chemical testing with a suitable risk assessment carried out.

##### 7.1.1.2 Groundwater

It is not considered likely that the ground conditions on site pose a significant risk to either the groundwater underlying the site nor surface water features in the vicinity of the site. Additionally, it is not considered likely that the groundwater beneath the site will be acting as a contaminant source.



### 7.1.1.3 Radon

The highest band of radon risk on site is 3-5%, indicating that there is a 3-5% likelihood of any building on site exceeding Radon Action Level of 200Bq/m<sup>3</sup>.

### 7.1.1.4 Waste Classification and Disposal

At the time of writing a soil mass balance for the project had not been produced for the proposed development. However, there is potential for the proposed development to generate surplus soils. Where possible, these soils should be either reused on site or sent to a waste recovery facility for recycling. Any soil disposed of will need to be tested to confirm suitability for reuse and/or waste classification. This testing should be carried out following completion of the excavation works and prior to reuse or disposal.

## 7.1.2 Objective and format of any investigation

The site has been an undeveloped field with little ground disturbance that may have led to the presence of contamination sources on site and as such, it is considered that the risk of active contaminant linkages to be present on site is low to very low. As such, intrusive ground investigation is not considered necessary as the geoenvironmental risks are not considered to be sufficiently high. However, ground investigation may be required, to inform geotechnical design, should the scheme be progressed beyond the current feasibility stage.

During any future stages of the scheme, should ground conditions be encountered which are outside of those detailed within this report, works should be stopped, samples of the suspect materials sampled and the geoenvironmental risks reassessed. The processes to be followed in the event of uncovering unexpected contamination should be detailed within a Discovery Strategy and provided to the contractor prior to commencing works.

## 7.2 Recommendations

Based on the geo-environmental risks identified and outlined within this report, it is recommended that a project specific ground investigation is undertaken to investigate/mitigate these risks, confirm the ground conditions beneath the site.

### 7.2.1 Utility Survey

There is no information on the location of buried services within or adjacent to the site; it is recommended that a utilities search is undertaken at an early stage in the development of the scheme's design in order to identify potential impediments. During the site walkover, an animal water trough was noted which was fed by blue alkathene pipe, the alignment of which anecdotally lies between the trough and the site entrance off St Brides Road; this should be confirmed prior to commencing any development works. The tenants also indicated that there were a series of redundant water pipes beneath the site which were used to provide water to other animal watering facilities which have been removed from site.

### 7.2.2 Radon

A site-specific Radon Search Address Report should be obtained to confirm the risks posed to the proposed development, particularly the brick-and-mortar utility block.

### 7.2.3 Discovery Strategy

A Discovery Strategy should be produced which will detail the steps to be followed should previously unidentified contamination be discovered, should the scheme progress to the construction stage. This should include the following:

- Potential indicators of contamination (visual or olfactory).

- Quarantine procedures to put in place.
- Testing requirements (number of samples, testing suites etc).
- Geoenvironmental assessment procedures, and
- Materials tracking and verification.

# **A. Groundsure Environmental and Geo Insight Report**

Land to rear of Langley Close Magor, NP26 3HW

**Order Details**

**Date:** 05/12/2023  
**Your ref:** Land\_to\_rear\_of\_Langley\_Close\_Magor  
**Our Ref:** GS-738-Y4J-OV7-OWD

**Site Details**

**Location:** 342182 187741  
**Area:** 2.81 ha  
**Authority:** [Sir Fynwy - Monmouthshire County Council](#) ↗



**Summary of findings**

[p. 2](#) >

**Aerial image**

[p. 9](#) >

**OS MasterMap site plan**

[p.14](#) >

[groundsure.com/insightuserguide](https://groundsure.com/insightuserguide) ↗

## Summary of findings

Page	Section	<a href="#">Past land use &gt;</a>	On site	0-50m	50-250m	250-500m	500-2000m
<a href="#">15 &gt;</a>	<a href="#">1.1 &gt;</a>	<a href="#">Historical industrial land uses &gt;</a>	0	1	16	31	-
<a href="#">17 &gt;</a>	<a href="#">1.2 &gt;</a>	<a href="#">Historical tanks &gt;</a>	0	0	0	13	-
<a href="#">18 &gt;</a>	<a href="#">1.3 &gt;</a>	<a href="#">Historical energy features &gt;</a>	0	0	3	9	-
19	1.4	Historical petrol stations	0	0	0	0	-
<a href="#">19 &gt;</a>	<a href="#">1.5 &gt;</a>	<a href="#">Historical garages &gt;</a>	0	0	3	9	-
20	1.6	Historical military land	0	0	0	0	-
Page	Section	<a href="#">Past land use - un-grouped &gt;</a>	On site	0-50m	50-250m	250-500m	500-2000m
<a href="#">21 &gt;</a>	<a href="#">2.1 &gt;</a>	<a href="#">Historical industrial land uses &gt;</a>	0	2	22	37	-
<a href="#">24 &gt;</a>	<a href="#">2.2 &gt;</a>	<a href="#">Historical tanks &gt;</a>	0	0	0	28	-
<a href="#">25 &gt;</a>	<a href="#">2.3 &gt;</a>	<a href="#">Historical energy features &gt;</a>	0	0	8	24	-
26	2.4	Historical petrol stations	0	0	0	0	-
<a href="#">27 &gt;</a>	<a href="#">2.5 &gt;</a>	<a href="#">Historical garages &gt;</a>	0	0	5	16	-
Page	Section	<a href="#">Waste and landfill &gt;</a>	On site	0-50m	50-250m	250-500m	500-2000m
29	3.1	Active or recent landfill	0	0	0	0	-
29	3.2	Historical landfill (BGS records)	0	0	0	0	-
30	3.3	Historical landfill (LA/mapping records)	0	0	0	0	-
<a href="#">30 &gt;</a>	<a href="#">3.4 &gt;</a>	<a href="#">Historical landfill (EA/NRW records) &gt;</a>	0	0	0	1	-
30	3.5	Historical waste sites	0	0	0	0	-
30	3.6	Licensed waste sites	0	0	0	0	-
<a href="#">31 &gt;</a>	<a href="#">3.7 &gt;</a>	<a href="#">Waste exemptions &gt;</a>	0	0	4	0	-
Page	Section	<a href="#">Current industrial land use &gt;</a>	On site	0-50m	50-250m	250-500m	500-2000m
<a href="#">32 &gt;</a>	<a href="#">4.1 &gt;</a>	<a href="#">Recent industrial land uses &gt;</a>	0	1	4	-	-
<a href="#">33 &gt;</a>	<a href="#">4.2 &gt;</a>	<a href="#">Current or recent petrol stations &gt;</a>	0	0	1	0	-
33	4.3	Electricity cables	0	0	0	0	-
33	4.4	Gas pipelines	0	0	0	0	-
34	4.5	Sites determined as Contaminated Land	0	0	0	0	-



34	4.6	Control of Major Accident Hazards (COMAH)	0	0	0	0	-	
34	4.7	Regulated explosive sites	0	0	0	0	-	
34	4.8	Hazardous substance storage/usage	0	0	0	0	-	
34	4.9	Historical licensed industrial activities (IPC)	0	0	0	0	-	
<a href="#">35</a> >	<a href="#">4.10</a> >	<a href="#">Licensed industrial activities (Part A(1))</a> >	0	0	0	14	-	
<a href="#">37</a> >	<a href="#">4.11</a> >	<a href="#">Licensed pollutant release (Part A(2)/B)</a> >	0	0	1	0	-	
38	4.12	Radioactive Substance Authorisations	0	0	0	0	-	
<a href="#">38</a> >	<a href="#">4.13</a> >	<a href="#">Licensed Discharges to controlled waters</a> >	0	0	4	0	-	
39	4.14	Pollutant release to surface waters (Red List)	0	0	0	0	-	
39	4.15	Pollutant release to public sewer	0	0	0	0	-	
39	4.16	List 1 Dangerous Substances	0	0	0	0	-	
39	4.17	List 2 Dangerous Substances	0	0	0	0	-	
<a href="#">39</a> >	<a href="#">4.18</a> >	<a href="#">Pollution Incidents (EA/NRW)</a> >	0	1	1	0	-	
40	4.19	Pollution inventory substances	0	0	0	0	-	
40	4.20	Pollution inventory waste transfers	0	0	0	0	-	
40	4.21	Pollution inventory radioactive waste	0	0	0	0	-	
Page	Section	<a href="#">Hydrogeology</a> >	On site	0-50m	50-250m	250-500m	500-2000m	
<a href="#">41</a> >	<a href="#">5.1</a> >	<a href="#">Superficial aquifer</a> >	Identified (within 500m)					
<a href="#">43</a> >	<a href="#">5.2</a> >	<a href="#">Bedrock aquifer</a> >	Identified (within 500m)					
<a href="#">45</a> >	<a href="#">5.3</a> >	<a href="#">Groundwater vulnerability</a> >	Identified (within 50m)					
<a href="#">46</a> >	<a href="#">5.4</a> >	<a href="#">Groundwater vulnerability- soluble rock risk</a> >	Identified (within 0m)					
46	5.5	Groundwater vulnerability- local information	None (within 0m)					
47	5.6	Groundwater abstractions	0	0	0	0	0	
47	5.7	Surface water abstractions	0	0	0	0	0	
47	5.8	Potable abstractions	0	0	0	0	0	
47	5.9	Source Protection Zones	0	0	0	0	-	
48	5.10	Source Protection Zones (confined aquifer)	0	0	0	0	-	
Page	Section	<a href="#">Hydrology</a> >	On site	0-50m	50-250m	250-500m	500-2000m	
<a href="#">49</a> >	<a href="#">6.1</a> >	<a href="#">Water Network (OS MasterMap)</a> >	0	0	6	-	-	



<a href="#">50</a> >	<a href="#">6.2</a> >	<a href="#">Surface water features</a> >	0	0	3	-	-
<a href="#">50</a> >	<a href="#">6.3</a> >	<a href="#">WFD Surface water body catchments</a> >	1	-	-	-	-
<a href="#">51</a> >	<a href="#">6.4</a> >	<a href="#">WFD Surface water bodies</a> >	0	0	1	-	-
<a href="#">51</a> >	<a href="#">6.5</a> >	<a href="#">WFD Groundwater bodies</a> >	1	-	-	-	-
Page	Section	<a href="#">River and coastal flooding</a> >	On site	0-50m	50-250m	250-500m	500-2000m
<a href="#">52</a> >	<a href="#">7.1</a> >	<a href="#">Risk of flooding from rivers and the sea</a> >	Low (within 50m)				
53	7.2	Historical Flood Events	0	0	0	-	-
53	7.3	Flood Defences	0	0	0	-	-
53	7.4	Areas Benefiting from Flood Defences	0	0	0	-	-
53	7.5	Flood Storage Areas	0	0	0	-	-
<a href="#">54</a> >	<a href="#">7.6</a> >	<a href="#">Flood Zone 2</a> >	Identified (within 50m)				
<a href="#">55</a> >	<a href="#">7.7</a> >	<a href="#">Flood Zone 3</a> >	Identified (within 50m)				
Page	Section	<a href="#">Surface water flooding</a> >					
<a href="#">56</a> >	<a href="#">8.1</a> >	<a href="#">Surface water flooding</a> >	1 in 30 year, 0.3m - 1.0m (within 50m)				
Page	Section	<a href="#">Groundwater flooding</a> >					
<a href="#">58</a> >	<a href="#">9.1</a> >	<a href="#">Groundwater flooding</a> >	Moderate (within 50m)				
Page	Section	<a href="#">Environmental designations</a> >	On site	0-50m	50-250m	250-500m	500-2000m
<a href="#">59</a> >	<a href="#">10.1</a> >	<a href="#">Sites of Special Scientific Interest (SSSI)</a> >	0	0	0	0	5
60	10.2	Conserved wetland sites (Ramsar sites)	0	0	0	0	0
60	10.3	Special Areas of Conservation (SAC)	0	0	0	0	0
60	10.4	Special Protection Areas (SPA)	0	0	0	0	0
<a href="#">61</a> >	<a href="#">10.5</a> >	<a href="#">National Nature Reserves (NNR)</a> >	0	0	0	0	1
61	10.6	Local Nature Reserves (LNR)	0	0	0	0	0
<a href="#">61</a> >	<a href="#">10.7</a> >	<a href="#">Designated Ancient Woodland</a> >	0	0	0	0	16
62	10.8	Biosphere Reserves	0	0	0	0	0
62	10.9	Forest Parks	0	0	0	0	0
63	10.10	Marine Conservation Zones	0	0	0	0	0
63	10.11	Green Belt	0	0	0	0	0
63	10.12	Proposed Ramsar sites	0	0	0	0	0



63	10.13	Possible Special Areas of Conservation (pSAC)	0	0	0	0	0
63	10.14	Potential Special Protection Areas (pSPA)	0	0	0	0	0
64	10.15	Nitrate Sensitive Areas	0	0	0	0	0
64	10.16	Nitrate Vulnerable Zones	0	0	0	0	0
<b>65 &gt;</b>	<b>10.17 &gt;</b>	<b><u>SSSI Impact Risk Zones &gt;</u></b>	1	-	-	-	-
66	10.18	SSSI Units	0	0	0	0	0
Page	Section	<b><u>Visual and cultural designations &gt;</u></b>	On site	0-50m	50-250m	250-500m	500-2000m
67	11.1	World Heritage Sites	0	0	0	-	-
68	11.2	Area of Outstanding Natural Beauty	0	0	0	-	-
68	11.3	National Parks	0	0	0	-	-
<b>68 &gt;</b>	<b>11.4 &gt;</b>	<b><u>Listed Buildings &gt;</u></b>	0	0	1	-	-
69	11.5	Conservation Areas	0	0	0	-	-
69	11.6	Scheduled Ancient Monuments	0	0	0	-	-
69	11.7	Registered Parks and Gardens	0	0	0	-	-
Page	Section	<b><u>Agricultural designations &gt;</u></b>	On site	0-50m	50-250m	250-500m	500-2000m
<b>70 &gt;</b>	<b>12.1 &gt;</b>	<b><u>Agricultural Land Classification &gt;</u></b>	Grade 4 (within 250m)				
71	12.2	Open Access Land	0	0	0	-	-
71	12.3	Tree Felling Licences	0	0	0	-	-
72	12.4	Environmental Stewardship Schemes	0	0	0	-	-
72	12.5	Countryside Stewardship Schemes	0	0	0	-	-
Page	Section	<b><u>Habitat designations</u></b>	On site	0-50m	50-250m	250-500m	500-2000m
73	13.1	Priority Habitat Inventory	0	0	0	-	-
73	13.2	Habitat Networks	0	0	0	-	-
73	13.3	Open Mosaic Habitat	0	0	0	-	-
73	13.4	Limestone Pavement Orders	0	0	0	-	-
Page	Section	<b><u>Geology 1:10,000 scale &gt;</u></b>	On site	0-50m	50-250m	250-500m	500-2000m
<b>74 &gt;</b>	<b>14.1 &gt;</b>	<b><u>10k Availability &gt;</u></b>	Identified (within 500m)				
75	14.2	Artificial and made ground (10k)	0	0	0	0	-
<b>76 &gt;</b>	<b>14.3 &gt;</b>	<b><u>Superficial geology (10k) &gt;</u></b>	2	1	3	1	-





77	14.4	Landslip (10k)	0	0	0	0	-
<a href="#">78</a> >	<a href="#">14.5</a> >	<a href="#">Bedrock geology (10k)</a> >	2	2	4	2	-
79	14.6	Bedrock faults and other linear features (10k)	0	0	0	0	-
Page	Section	<a href="#">Geology 1:50,000 scale</a> >	On site	0-50m	50-250m	250-500m	500-2000m
<a href="#">80</a> >	<a href="#">15.1</a> >	<a href="#">50k Availability</a> >	Identified (within 500m)				
81	15.2	Artificial and made ground (50k)	0	0	0	0	-
81	15.3	Artificial ground permeability (50k)	0	0	-	-	-
<a href="#">82</a> >	<a href="#">15.4</a> >	<a href="#">Superficial geology (50k)</a> >	2	1	4	0	-
<a href="#">83</a> >	<a href="#">15.5</a> >	<a href="#">Superficial permeability (50k)</a> >	Identified (within 50m)				
83	15.6	Landslip (50k)	0	0	0	0	-
83	15.7	Landslip permeability (50k)	None (within 50m)				
<a href="#">84</a> >	<a href="#">15.8</a> >	<a href="#">Bedrock geology (50k)</a> >	2	0	5	2	-
<a href="#">85</a> >	<a href="#">15.9</a> >	<a href="#">Bedrock permeability (50k)</a> >	Identified (within 50m)				
85	15.10	Bedrock faults and other linear features (50k)	0	0	0	0	-
Page	Section	<a href="#">Boreholes</a> >	On site	0-50m	50-250m	250-500m	500-2000m
<a href="#">86</a> >	<a href="#">16.1</a> >	<a href="#">BGS Boreholes</a> >	1	3	21	-	-
Page	Section	<a href="#">Natural ground subsidence</a> >					
<a href="#">89</a> >	<a href="#">17.1</a> >	<a href="#">Shrink swell clays</a> >	Negligible (within 50m)				
<a href="#">90</a> >	<a href="#">17.2</a> >	<a href="#">Running sands</a> >	Very low (within 50m)				
<a href="#">92</a> >	<a href="#">17.3</a> >	<a href="#">Compressible deposits</a> >	Negligible (within 50m)				
<a href="#">93</a> >	<a href="#">17.4</a> >	<a href="#">Collapsible deposits</a> >	Very low (within 50m)				
<a href="#">94</a> >	<a href="#">17.5</a> >	<a href="#">Landslides</a> >	Very low (within 50m)				
<a href="#">96</a> >	<a href="#">17.6</a> >	<a href="#">Ground dissolution of soluble rocks</a> >	Moderate (within 50m)				
Page	Section	<a href="#">Mining and ground workings</a> >	On site	0-50m	50-250m	250-500m	500-2000m
<a href="#">98</a> >	<a href="#">18.1</a> >	<a href="#">BritPits</a> >	0	0	3	4	-
<a href="#">100</a> >	<a href="#">18.2</a> >	<a href="#">Surface ground workings</a> >	0	2	20	-	-
101	18.3	Underground workings	0	0	0	0	0
101	18.4	Underground mining extents	0	0	0	0	-
101	18.5	Historical Mineral Planning Areas	0	0	0	0	-



<a href="#">102</a> >	<a href="#">18.6</a> >	<a href="#">Non-coal mining</a> >	1	0	1	0	0
102	18.7	JPB mining areas	None (within 0m)				
102	18.8	The Coal Authority non-coal mining	0	0	0	0	-
103	18.9	Researched mining	0	0	0	0	-
103	18.10	Mining record office plans	0	0	0	0	-
103	18.11	BGS mine plans	0	0	0	0	-
103	18.12	Coal mining	None (within 0m)				
103	18.13	Brine areas	None (within 0m)				
104	18.14	Gypsum areas	None (within 0m)				
104	18.15	Tin mining	None (within 0m)				
104	18.16	Clay mining	None (within 0m)				
Page	Section	Ground cavities and sinkholes	On site	0-50m	50-250m	250-500m	500-2000m
105	19.1	Natural cavities	0	0	0	0	-
105	19.2	Mining cavities	0	0	0	0	0
105	19.3	Reported recent incidents	0	0	0	0	-
105	19.4	Historical incidents	0	0	0	0	-
106	19.5	National karst database	0	0	0	0	-
Page	Section	<a href="#">Radon</a> >					
<a href="#">107</a> >	<a href="#">20.1</a> >	<a href="#">Radon</a> >	Between 3% and 5% (within 0m)				
Page	Section	<a href="#">Soil chemistry</a> >	On site	0-50m	50-250m	250-500m	500-2000m
<a href="#">109</a> >	<a href="#">21.1</a> >	<a href="#">BGS Estimated Background Soil Chemistry</a> >	5	1	-	-	-
109	21.2	BGS Estimated Urban Soil Chemistry	0	0	-	-	-
110	21.3	BGS Measured Urban Soil Chemistry	0	0	-	-	-
Page	Section	Railway infrastructure and projects	On site	0-50m	50-250m	250-500m	500-2000m
111	22.1	Underground railways (London)	0	0	0	-	-
111	22.2	Underground railways (Non-London)	0	0	0	-	-
111	22.3	Railway tunnels	0	0	0	-	-
111	22.4	Historical railway and tunnel features	0	0	0	-	-
111	22.5	Royal Mail tunnels	0	0	0	-	-

112	22.6	Historical railways	0	0	0	-	-
112	22.7	Railways	0	0	0	-	-
112	22.8	Crossrail 1	0	0	0	0	-
112	22.9	Crossrail 2	0	0	0	0	-
112	22.10	HS2	0	0	0	0	-

## Recent aerial photograph



Capture Date: 14/04/2020

Site Area: 2.81ha



## Recent site history - 2017 aerial photograph



Capture Date: 26/05/2017

Site Area: 2.81ha



## Recent site history - 2010 aerial photograph



Capture Date: 23/05/2010

Site Area: 2.81ha



## Recent site history - 2009 aerial photograph



Capture Date: 12/10/2009

Site Area: 2.81ha



## Recent site history - 2000 aerial photograph



Capture Date: 21/07/2000

Site Area: 2.81ha





## OS MasterMap site plan

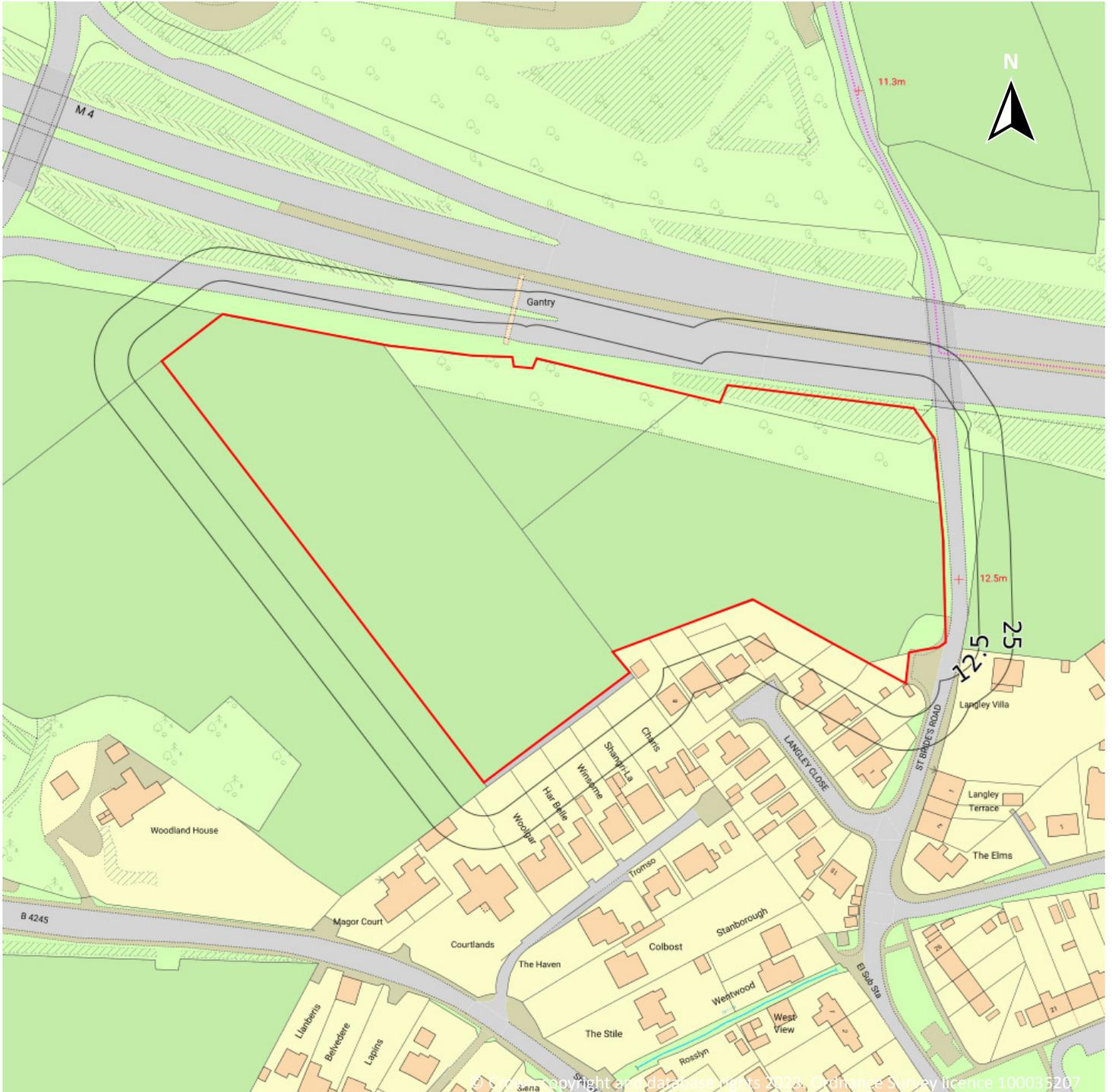

Site Area: 2.81ha



## 1 Past land use

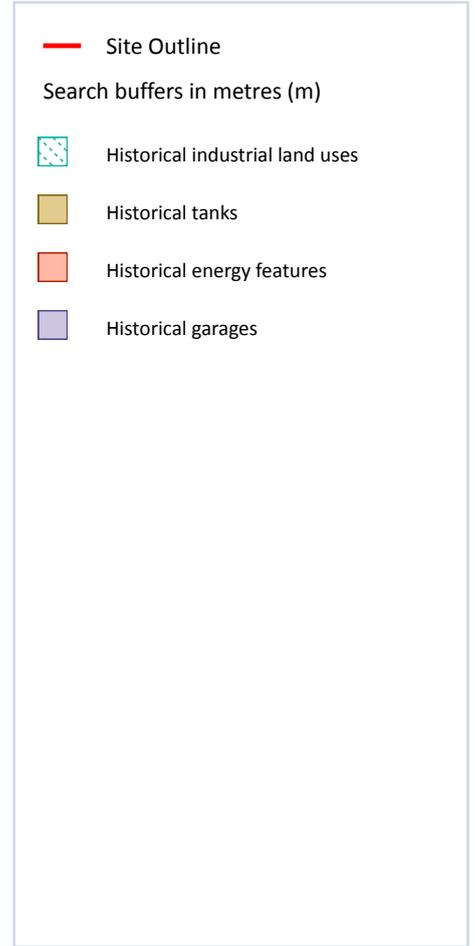
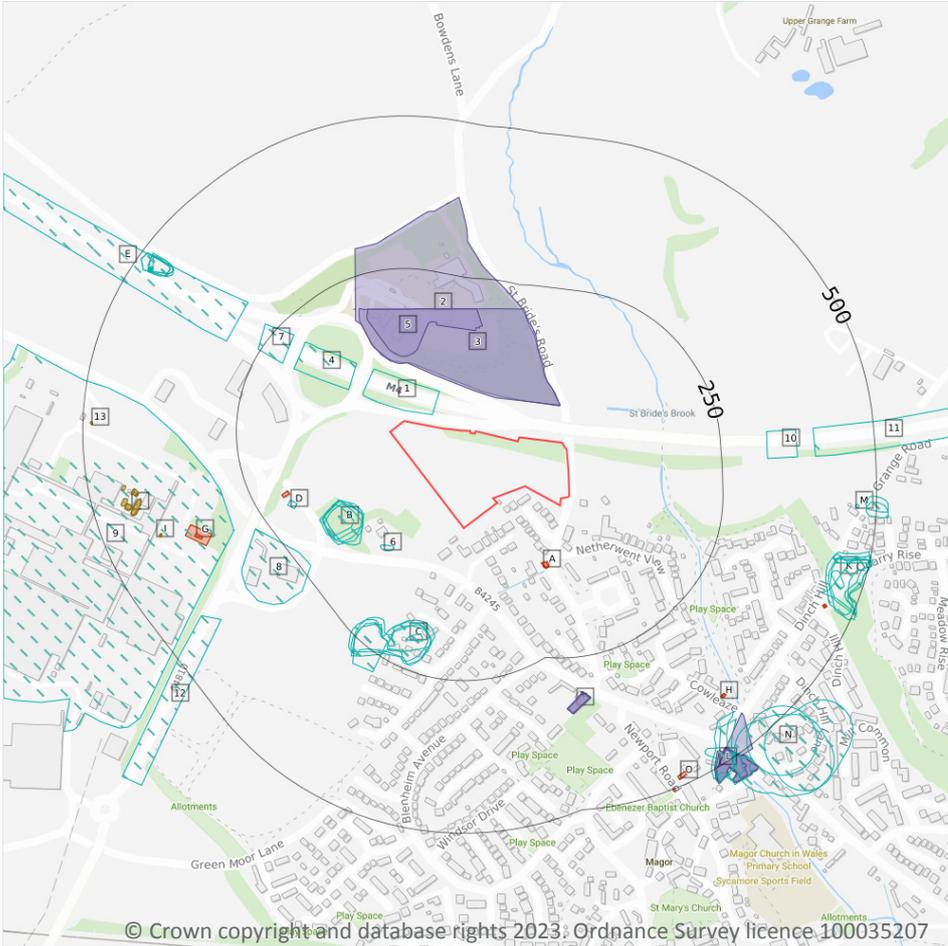

### 1.1 Historical industrial land uses

**Records within 500m** **48**

Potentially contaminative land use features digitised from historical Ordnance Survey mapping at 1:10,000 and 1:10,560 scale, intelligently grouped into contiguous features. To prevent misrepresentation of the size of historical features at any given time, features are only grouped if they have similar geometries within immediately preceding or succeeding map editions. See section 2 for a breakdown of grouping if required. Grouped and the original un-grouped features can be cross-referenced across sections 1 and 2 using the 'Group ID'.

Features are displayed on the Past land use map on [page 15](#) >

ID	Location	Land use	Dates present	Group ID
1	17m NW	Cuttings	1969 - 1988	1203190

ID	Location	Land use	Dates present	Group ID
4	97m NW	Cuttings	1969 - 1988	1242363
6	109m SW	Unspecified Ground Workings	1922	1209845
B	115m W	Unspecified Old Quarries	1963	1238292
B	115m W	Unspecified Ground Workings	1969 - 1988	1266514
B	118m W	Unspecified Old Quarries	1919 - 1949	1261255
B	125m SW	Unspecified Quarry	1881	1169874
B	135m SW	Unspecified Old Quarries	1902	1193414
C	166m S	Unspecified Old Quarries	1922 - 1949	1254648
C	173m S	Unspecified Old Quarries	1963	1220231
C	174m S	Unspecified Ground Workings	1969	1161029
C	177m S	Unspecified Old Quarries	1902	1191886
C	187m S	Unspecified Pit	1881	1186015
D	192m W	Police Station	1988	1180408
C	207m SW	Unspecified Pit	1881	1186014
7	208m NW	Cuttings	1969 - 1988	1242331
8	235m SW	Unspecified Depot	1988	1171295
9	292m W	Brewery	1988	1174585
E	305m NW	Cuttings	1969 - 1988	1233564
10	325m E	Cuttings	1969	1158513
11	402m E	Cuttings	1969 - 1988	1217906
12	405m SW	Cuttings	1988	1158512
K	435m E	Unspecified Quarry	1963	1248763
L	437m SE	Unspecified Mill	1963	1165943
E	438m NW	Unspecified Old Quarry	1963	1199472
E	440m NW	Unspecified Old Quarry	1922	1199233
E	440m NW	Unspecified Old Quarry	1922	1246306
K	441m E	Unspecified Quarry	1949	1196203
K	441m E	Unspecified Quarry	1902	1246289



ID	Location	Land use	Dates present	Group ID
K	441m E	Unspecified Quarry	1922	1253795
K	444m E	Unspecified Quarry	1902	1227796
K	445m E	Unspecified Quarry	1881	1235942
E	446m NW	Unspecified Old Quarry	1949	1201852
E	446m NW	Unspecified Old Quarry	1900	1269323
K	446m E	Unspecified Quarry	1919	1218719
L	447m SE	Mill Pond	1881	1168260
M	466m E	Unspecified Tank	1881	1175955
E	468m NW	Old Lime Kiln	1963	1214354
E	469m NW	Old Lime Kiln	1922	1245400
E	469m NW	Old Lime Kiln	1949	1208591
E	470m NW	Lime Kiln	1922	1217596
N	471m SE	Old Quay	1881	1247134
E	471m NW	Lime Kiln	1882	1201188
N	472m SE	Old Quay	1949 - 1963	1196959
M	482m E	Unspecified Old Quarry	1963	1267214
M	484m E	Unspecified Old Quarry	1919 - 1949	1261604
L	493m SE	Sawmill	1922 - 1949	1237949
N	498m SE	Old Quay	1902	1213795

*This data is sourced from Ordnance Survey / Groundsure.*

## 1.2 Historical tanks

**Records within 500m**

**13**

Tank features digitised from historical Ordnance Survey mapping at high-detail 1:1,250 and 1:2,500 scale, intelligently grouped into contiguous features. To prevent misrepresentation of the size of historical features at any given time, features are only grouped if they have similar geometries within immediately preceding or succeeding map editions. See section 2 for a breakdown of grouping if required. Grouped and the original ungrouped features can be cross-referenced across sections 1 and 2 using the 'Group ID'.

Features are displayed on the Past land use map on [page 15 >](#)



ID	Location	Land use	Dates present	Group ID
I	407m W	Unspecified Tank	1992	186869
I	409m W	Unspecified Tank	1997 - 1999	190641
J	419m W	Tanks	1992 - 1999	180622
J	420m W	Tanks	1980	190646
J	421m W	Tanks	1992	192766
J	423m W	Tanks	1997 - 1999	189655
J	424m W	Tanks	1980	190827
J	426m W	Tanks	1980 - 1999	188405
J	437m W	Tanks	1992 - 1999	181411
J	438m W	Tanks	1980	188455
J	439m W	Tanks	1980 - 1999	189485
J	442m W	Tanks	1980 - 1999	185644
13	484m W	Unspecified Tank	1980 - 1992	189724

This data is sourced from Ordnance Survey / Groundsure.

### 1.3 Historical energy features

<b>Records within 500m</b>	<b>12</b>
----------------------------	-----------

Energy features digitised from historical Ordnance Survey mapping at high-detail 1:1,250 and 1:2,500 scale, intelligently grouped into contiguous features. To prevent misrepresentation of the size of historical features at any given time, features are only grouped if they have similar geometries within immediately preceding or succeeding map editions. See section 2 for a breakdown of grouping if required. Grouped and the original ungrouped features can be cross-referenced across sections 1 and 2 using the 'Group ID'.

Features are displayed on the Past land use map on [page 15 >](#)

ID	Location	Land use	Dates present	Group ID
A	94m SE	Electricity Substation	1982	112860
A	94m SE	Electricity Substation	1986 - 1997	113146
D	193m W	Gas Governor	1997 - 1999	103472
G	335m W	Gas Governor	1992 - 1997	103644
G	350m W	Gas Governor	1999	111005



ID	Location	Land use	Dates present	Group ID
H	407m SE	Electricity Substation	1988 - 1992	112639
H	407m SE	Electricity Substation	1982 - 1997	103360
K	450m E	Electricity Substation	1981 - 1992	108181
K	450m E	Electricity Substation	1996 - 1997	109904
K	451m E	Electricity Substation	1986	101012
O	480m SE	Electricity Substation	1997	97615
O	499m SE	Electricity Substation	1978 - 1992	106644

This data is sourced from Ordnance Survey / Groundsure.

## 1.4 Historical petrol stations

**Records within 500m**

**0**

Petrol stations digitised from historical Ordnance Survey mapping at high-detail 1:1,250 and 1:2,500 scale, intelligently grouped into contiguous features. To prevent misrepresentation of the size of historical features at any given time, features are only grouped if they have similar geometries within immediately preceding or succeeding map editions. See section 2 for a breakdown of grouping if required. Grouped and the original ungrouped features can be cross-referenced across sections 1 and 2 using the 'Group ID'.

This data is sourced from Ordnance Survey / Groundsure.

## 1.5 Historical garages

**Records within 500m**

**12**

Garages digitised from historical Ordnance Survey mapping at high-detail 1:1,250 and 1:2,500 scale, intelligently grouped into contiguous features. To prevent misrepresentation of the size of historical features at any given time, features are only grouped if they have similar geometries within immediately preceding or succeeding map editions. See section 2 for a breakdown of grouping if required. Grouped and the original ungrouped features can be cross-referenced across sections 1 and 2 using the 'Group ID'.

Features are displayed on the Past land use map on [page 15 >](#)

ID	Location	Land use	Dates present	Group ID
2	59m NE	Service Area	1992 - 1994	35310
3	60m NE	Service Area	1997	33053
5	106m NW	Service Area	1996	33737
F	307m SE	Garage	1986	33516



ID	Location	Land use	Dates present	Group ID
F	308m SE	Garage	1996 - 1997	36692
F	308m SE	Garage	1988 - 1992	35122
L	450m SE	Garage	1967	33855
L	477m SE	Garage	1988 - 1997	36448
L	478m SE	Garage	1986	33297
L	479m SE	Garage	1981	33298
L	482m SE	Garage	1982	33122
L	497m SE	Garage	1978	34099

*This data is sourced from Ordnance Survey / Groundsure.*

## 1.6 Historical military land

<b>Records within 500m</b>	<b>0</b>
----------------------------	----------

Areas of military land digitised from multiple sources including the National Archives, local records, MOD records and verified other sources, intelligently grouped into contiguous features.

*This data is sourced from Ordnance Survey / Groundsure / other sources.*

## 2 Past land use - un-grouped

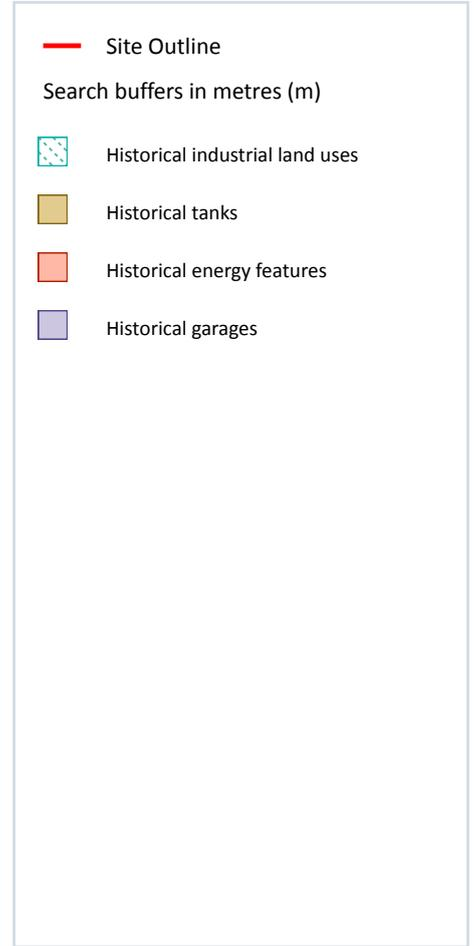
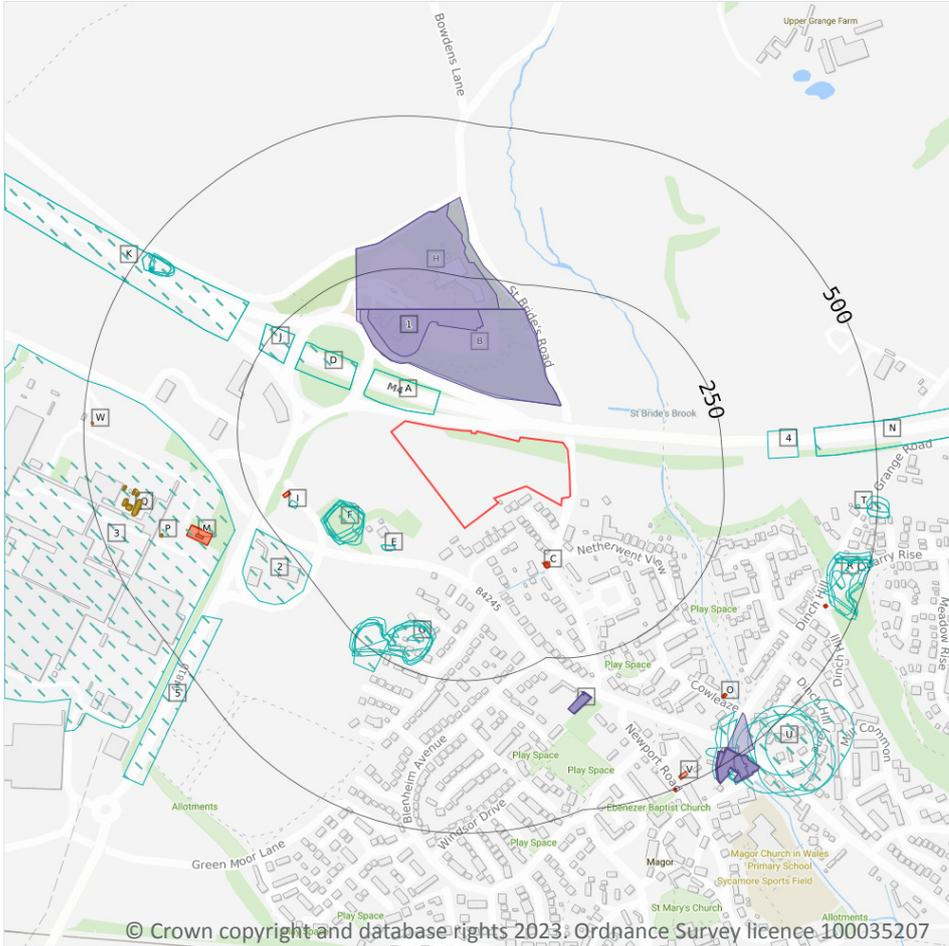

### 2.1 Historical industrial land uses

**Records within 500m** **61**

Potentially contaminative land use features digitised from historical Ordnance Survey mapping at 1:10,000 and 10,560 scale. Any records shown are available intelligently grouped in section 1. Grouped and the original un-grouped features can be cross-referenced across sections 1 and 2 using the 'Group ID'.

Features are displayed on the Past land use - un-grouped map on [page 21](#) >

ID	Location	Land Use	Date	Group ID
A	17m NW	Cuttings	1988	1203190
A	17m NW	Cuttings	1969	1203190
D	97m NW	Cuttings	1988	1242363



ID	Location	Land Use	Date	Group ID
D	97m NW	Cuttings	1969	1242363
E	109m SW	Unspecified Ground Workings	1922	1209845
E	109m SW	Unspecified Ground Workings	1922	1209845
F	115m W	Unspecified Old Quarries	1963	1238292
F	115m W	Unspecified Ground Workings	1988	1266514
F	118m W	Unspecified Ground Workings	1969	1266514
F	118m W	Unspecified Old Quarries	1949	1261255
F	118m W	Unspecified Old Quarries	1919	1261255
F	125m SW	Unspecified Quarry	1881	1169874
F	135m SW	Unspecified Old Quarries	1902	1193414
G	166m S	Unspecified Old Quarries	1922	1254648
G	173m S	Unspecified Old Quarries	1963	1220231
G	174m S	Unspecified Ground Workings	1969	1161029
G	176m S	Unspecified Old Quarries	1949	1254648
G	177m S	Unspecified Old Quarries	1902	1191886
G	187m S	Unspecified Pit	1881	1186015
I	192m W	Police Station	1988	1180408
G	207m SW	Unspecified Pit	1881	1186014
J	208m NW	Cuttings	1988	1242331
J	208m NW	Cuttings	1969	1242331
2	235m SW	Unspecified Depot	1988	1171295
3	292m W	Brewery	1988	1174585
K	305m NW	Cuttings	1988	1233564
K	305m NW	Cuttings	1969	1233564
4	325m E	Cuttings	1969	1158513
N	402m E	Cuttings	1988	1217906
N	402m E	Cuttings	1969	1217906
5	405m SW	Cuttings	1988	1158512



ID	Location	Land Use	Date	Group ID
R	435m E	Unspecified Quarry	1963	1248763
S	437m SE	Unspecified Mill	1963	1165943
K	438m NW	Unspecified Old Quarry	1963	1199472
K	440m NW	Unspecified Old Quarry	1922	1199233
K	440m NW	Unspecified Old Quarry	1922	1246306
R	441m E	Unspecified Quarry	1949	1196203
R	441m E	Unspecified Quarry	1902	1246289
R	441m E	Unspecified Quarry	1922	1253795
R	444m E	Unspecified Quarry	1902	1227796
R	445m E	Unspecified Quarry	1881	1235942
K	446m NW	Unspecified Old Quarry	1949	1201852
K	446m NW	Unspecified Old Quarry	1900	1269323
R	446m E	Unspecified Quarry	1949	1196203
R	446m E	Unspecified Quarry	1919	1218719
S	447m SE	Mill Pond	1881	1168260
T	466m E	Unspecified Tank	1881	1175955
K	468m NW	Old Lime Kiln	1963	1214354
K	469m NW	Old Lime Kiln	1922	1245400
K	469m NW	Old Lime Kiln	1949	1208591
K	470m NW	Lime Kiln	1922	1217596
U	471m SE	Old Quay	1881	1247134
K	471m NW	Lime Kiln	1882	1201188
U	472m SE	Old Quay	1963	1196959
T	482m E	Unspecified Old Quarry	1963	1267214
T	484m E	Unspecified Old Quarry	1949	1261604
T	484m E	Unspecified Old Quarry	1919	1261604
U	490m SE	Old Quay	1949	1196959
S	493m SE	Sawmill	1922	1237949



ID	Location	Land Use	Date	Group ID
S	496m SE	Sawmill	1949	1237949
U	498m SE	Old Quay	1902	1213795

This data is sourced from Ordnance Survey / Groundsure.

## 2.2 Historical tanks

Records within 500m

28

Tank features digitised from historical Ordnance Survey mapping at high-detail 1:1,250 and 1:2,500 scale. Any records shown are available intelligently grouped in section 1. Grouped and the original un-grouped features can be cross-referenced across sections 1 and 2 using the 'Group ID'.

Features are displayed on the Past land use - un-grouped map on [page 21 >](#)

ID	Location	Land Use	Date	Group ID
P	407m W	Unspecified Tank	1992	186869
P	409m W	Unspecified Tank	1997	190641
P	409m W	Unspecified Tank	1999	190641
Q	419m W	Tanks	1992	180622
Q	420m W	Tanks	1980	190646
Q	421m W	Tanks	1992	192766
Q	421m W	Tanks	1997	180622
Q	421m W	Tanks	1999	180622
Q	423m W	Tanks	1997	189655
Q	423m W	Tanks	1999	189655
Q	424m W	Tanks	1980	190827
Q	426m W	Tanks	1980	188405
Q	427m W	Tanks	1997	188405
Q	427m W	Tanks	1999	188405
Q	437m W	Tanks	1992	181411
Q	438m W	Tanks	1980	188455
Q	439m W	Tanks	1992	189485
Q	439m W	Tanks	1997	181411



ID	Location	Land Use	Date	Group ID
Q	439m W	Tanks	1999	181411
Q	440m W	Tanks	1980	189485
Q	441m W	Tanks	1997	189485
Q	441m W	Tanks	1999	189485
Q	442m W	Tanks	1992	185644
Q	442m W	Tanks	1980	185644
Q	444m W	Tanks	1997	185644
Q	444m W	Tanks	1999	185644
W	484m W	Unspecified Tank	1992	189724
W	485m W	Unspecified Tank	1980	189724

This data is sourced from Ordnance Survey / Groundsure.

## 2.3 Historical energy features

Records within 500m

32

Energy features digitised from historical Ordnance Survey mapping at high-detail 1:1,250 and 1:2,500 scale. Any records shown are available intelligently grouped in section 1. Grouped and the original un-grouped features can be cross-referenced across sections 1 and 2 using the 'Group ID'.

Features are displayed on the Past land use - un-grouped map on [page 21 >](#)

ID	Location	Land Use	Date	Group ID
C	94m SE	Electricity Substation	1982	112860
C	94m SE	Electricity Substation	1986	113146
C	96m SE	Electricity Substation	1988	113146
C	96m SE	Electricity Substation	1992	113146
C	96m SE	Electricity Substation	1990	113146
C	98m SE	Electricity Substation	1997	113146
I	193m W	Gas Governor	1997	103472
I	193m W	Gas Governor	1999	103472
M	335m W	Gas Governor	1992	103644
M	336m W	Gas Governor	1997	103644



ID	Location	Land Use	Date	Group ID
M	350m W	Gas Governor	1999	111005
O	407m SE	Electricity Substation	1988	112639
O	407m SE	Electricity Substation	1992	112639
O	407m SE	Electricity Substation	1990	112639
O	407m SE	Electricity Substation	1997	103360
O	407m SE	Electricity Substation	1996	103360
O	407m SE	Electricity Substation	1986	103360
O	408m SE	Electricity Substation	1982	103360
R	450m E	Electricity Substation	1981	108181
R	450m E	Electricity Substation	1988	108181
R	450m E	Electricity Substation	1992	108181
R	450m E	Electricity Substation	1990	108181
R	450m E	Electricity Substation	1997	109904
R	450m E	Electricity Substation	1996	109904
R	450m E	Electricity Substation	1982	108181
R	451m E	Electricity Substation	1986	101012
V	480m SE	Electricity Substation	1997	97615
V	499m SE	Electricity Substation	1978	106644
V	499m SE	Electricity Substation	1981	106644
V	499m SE	Electricity Substation	1988	106644
V	499m SE	Electricity Substation	1992	106644
V	499m SE	Electricity Substation	1990	106644

This data is sourced from Ordnance Survey / Groundsure.

## 2.4 Historical petrol stations

Records within 500m

0

Petrol stations digitised from historical Ordnance Survey mapping at high-detail 1:1,250 and 1:2,500 scale. Any records shown are available intelligently grouped in section 1. Grouped and the original un-grouped features can be cross-referenced across sections 1 and 2 using the 'Group ID'.



This data is sourced from Ordnance Survey / Groundsure.

## 2.5 Historical garages

Records within 500m

21

Garages digitised from historical Ordnance Survey mapping at high-detail 1:1,250 and 1:2,500 scale. Any records shown are available intelligently grouped in section 1. Grouped and the original un-grouped features can be cross-referenced across sections 1 and 2 using the 'Group ID'.

Features are displayed on the Past land use - un-grouped map on [page 21](#) >

ID	Location	Land Use	Date	Group ID
B	59m NE	Service Area	1992	35310
B	60m NE	Service Area	1997	33053
1	106m NW	Service Area	1996	33737
H	183m NW	Service Area	1994	35310
H	183m NW	Service Area	1992	35310
L	307m SE	Garage	1986	33516
L	308m SE	Garage	1997	36692
L	308m SE	Garage	1996	36692
L	308m SE	Garage	1988	35122
L	308m SE	Garage	1992	35122
L	308m SE	Garage	1990	35122
S	450m SE	Garage	1967	33855
S	477m SE	Garage	1988	36448
S	477m SE	Garage	1992	36448
S	477m SE	Garage	1990	36448
S	478m SE	Garage	1986	33297
S	479m SE	Garage	1997	36448
S	479m SE	Garage	1996	36448
S	479m SE	Garage	1981	33298
S	482m SE	Garage	1982	33122
S	497m SE	Garage	1978	34099



*This data is sourced from Ordnance Survey / Groundsure.*



### 3 Waste and landfill

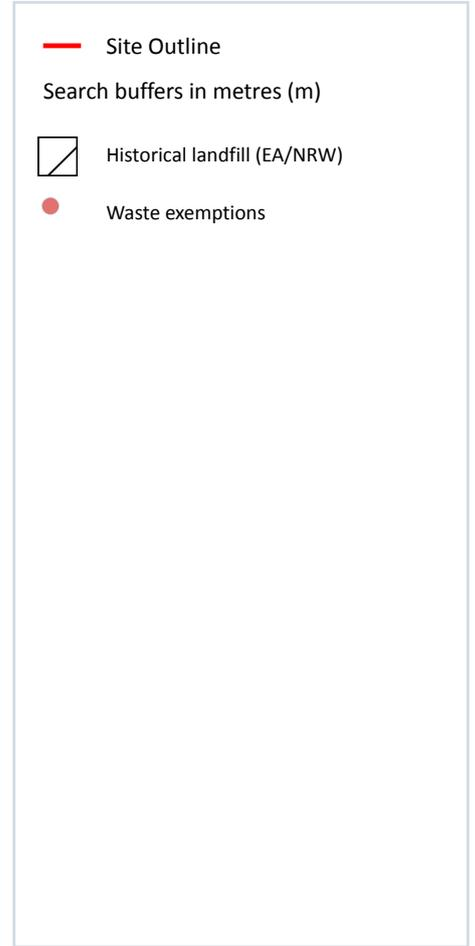

#### 3.1 Active or recent landfill

**Records within 500m** **0**

Active or recently closed landfill sites under Environment Agency/Natural Resources Wales regulation.

*This data is sourced from the Environment Agency and Natural Resources Wales.*

#### 3.2 Historical landfill (BGS records)

**Records within 500m** **0**

Landfill sites identified on a survey carried out on behalf of the DoE in 1973. These sites may have been closed or operational at this time.

*This data is sourced from the British Geological Survey.*



### 3.3 Historical landfill (LA/mapping records)

Records within 500m

0

Landfill sites identified from Local Authority records and high detail historical mapping.

*This data is sourced from the Ordnance Survey/Groundsure and Local Authority records.*

### 3.4 Historical landfill (EA/NRW records)

Records within 500m

1

Known historical (closed) landfill sites (e.g. sites where there is no PPC permit or waste management licence currently in force). This includes sites that existed before the waste licensing regime and sites that have been licensed in the past but where a licence has been revoked, ceased to exist or surrendered and a certificate of completion has been issued.

Features are displayed on the Waste and landfill map on [page 29 >](#)

ID	Location	Details		
1	407m E	Site Address: Land off Dancing Hill, Magor, Monmouthshire Licence Holder Address: -	Waste Licence: Yes Site Reference: MBC 23, MBC24 Waste Type: Inert, Household Environmental Permitting Regulations (Waste) Reference: - Licence Issue: - Licence Surrender: -	Operator: - Licence Holder: Monmouthshire Borough Council First Recorded - Last Recorded: -

*This data is sourced from the Environment Agency and Natural Resources Wales.*

### 3.5 Historical waste sites

Records within 500m

0

Waste site records derived from Local Authority planning records and high detail historical mapping.

*This data is sourced from Ordnance Survey/Groundsure and Local Authority records.*

### 3.6 Licensed waste sites

Records within 500m

0

Active or recently closed waste sites under Environment Agency/Natural Resources Wales regulation.

*This data is sourced from the Environment Agency and Natural Resources Wales.*

### 3.7 Waste exemptions

Records within 500m

4

Activities involving the storage, treatment, use or disposal of waste that are exempt from needing a permit. Exemptions have specific limits and conditions that must be adhered to.

Features are displayed on the Waste and landfill map on [page 29 >](#)

ID	Location	Site	Reference	Category	Sub-Category	Description
A	129m S	Monmouthshire County Council, Welsh Assembly Government Motorway Depot (Wilcrick), Newport Road (Off Jct. 23 M4), Magor, Monmouthshire, NP26 3BZ	NRW-WME068614	Storing waste exemption	Not on a farm	Storage of waste in a secure place
A	129m S	Monmouthshire County Council, Welsh Assembly Government Motorway Depot (Wilcrick), Newport Road (Off Jct. 23 M4), Magor, Monmouthshire, NP26 3BZ	NRW-WME068614	Using waste exemption	Not on a farm	Use of waste in construction
A	129m S	Monmouthshire County Council, Monmouthshire County Council, Welsh Assembly Government Motorway Depot (Wilcrick), Newport Road (Off Jct 23 M4), Magor, Monmouthshire, NP263BZ	NRW-WME033966	Using waste exemption	Not on a farm	Use of waste in construction
A	129m S	Monmouthshire County Council, Monmouthshire County Council, Welsh Assembly Government Motorway Depot (Wilcrick), Newport Road (Off Jct 23 M4), Magor, Monmouthshire, NP263BZ	NRW-WME033966	Storing waste exemption	Not on a farm	Storage of waste in a secure place

This data is sourced from the Environment Agency and Natural Resources Wales.



## 4 Current industrial land use

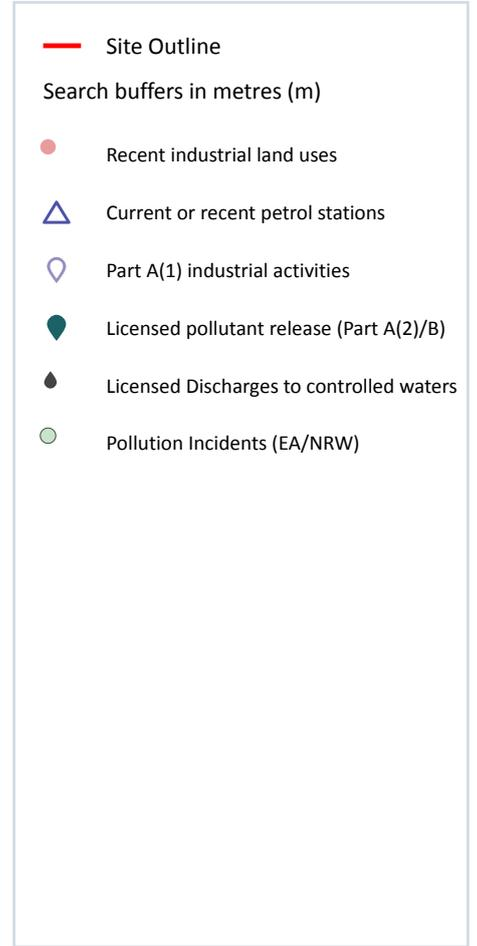

### 4.1 Recent industrial land uses

Records within 250m

5

Current potentially contaminative industrial sites.

Features are displayed on the Current industrial land use map on [page 32 >](#)

ID	Location	Company	Address	Activity	Category
1	21m N	Gantry	Gwent, NP26	Travelling Cranes and Gantries	Industrial Features
3	98m SE	Electricity Sub Station	Gwent, NP26	Electrical Features	Infrastructure and Facilities
A	168m NW	BP Service Station	Esso Service Station Magor Motorway Service Area, -, Magor, Gwent, NP26 3YL	Petrol and Fuel Stations	Road and Rail



ID	Location	Company	Address	Activity	Category
5	197m W	Gas Governor Station	Gwent, NP26	Gas Features	Infrastructure and Facilities
A	210m NW	Electricity Sub Station	Gwent, NP26	Electrical Features	Infrastructure and Facilities

*This data is sourced from Ordnance Survey.*

## 4.2 Current or recent petrol stations

**Records within 500m**

**1**

Open, closed, under development and obsolete petrol stations.

Features are displayed on the Current industrial land use map on [page 32 >](#)

ID	Location	Company	Address	LPG	Status
A	144m NW	BP	M4 J23a, B4245, Magor, Newport, Monmouthshire, NP26 3YL	No	Open

*This data is sourced from Experian.*

## 4.3 Electricity cables

**Records within 500m**

**0**

High voltage underground electricity transmission cables.

*This data is sourced from National Grid.*

## 4.4 Gas pipelines

**Records within 500m**

**0**

High pressure underground gas transmission pipelines.

*This data is sourced from National Grid.*



#### 4.5 Sites determined as Contaminated Land

Records within 500m	0
---------------------	---

Contaminated Land Register of sites designated under Part 2a of the Environmental Protection Act 1990.

*This data is sourced from Local Authority records.*

#### 4.6 Control of Major Accident Hazards (COMAH)

Records within 500m	0
---------------------	---

Control of Major Accident Hazards (COMAH) sites. This data includes upper and lower tier sites, and includes a historical archive of COMAH sites and Notification of Installations Handling Hazardous Substances (NIHHS) records.

*This data is sourced from the Health and Safety Executive.*

#### 4.7 Regulated explosive sites

Records within 500m	0
---------------------	---

Sites registered and licensed by the Health and Safety Executive under the Manufacture and Storage of Explosives Regulations 2005 (MSER). The last update to this data was in April 2011.

*This data is sourced from the Health and Safety Executive.*

#### 4.8 Hazardous substance storage/usage

Records within 500m	0
---------------------	---

Consents granted for a site to hold certain quantities of hazardous substances at or above defined limits in accordance with the Planning (Hazardous Substances) Regulations 2015.

*This data is sourced from Local Authority records.*

#### 4.9 Historical licensed industrial activities (IPC)

Records within 500m	0
---------------------	---

Integrated Pollution Control (IPC) records of substance releases to air, land and water. This data represents a historical archive as the IPC regime has been superseded.

*This data is sourced from the Environment Agency and Natural Resources Wales.*

## 4.10 Licensed industrial activities (Part A(1))

Records within 500m

14

Records of Part A(1) installations regulated under the Environmental Permitting (England and Wales) Regulations 2016 for the release of substances to the environment.

Features are displayed on the Current industrial land use map on [page 32](#) >

ID	Location	Details	
C	498m W	Operator: AB InBev UK Ltd Installation Name: Magor Brewery EPR/BX7282IS Process: DISPOSAL OF NON-HAZARDOUS WASTE WITH A CAPACITY EXCEEDING 50 TONNES PER DAY (OR 100 TONNES PER DAY IF THE ONLY WASTE TREATMENT ACTIVITY IS ANAEROBIC DIGESTION) INVOLVING ONE OR MORE OF THE FOLLOWING ACTIVITIES, AND EXCLUDING ACTIVITIES COVERED BY COUNCIL DIRECTIVE 91/271/EEC CONCERNING URBAN WASTE-WATER TREATMENT(4)—BIOLOGICAL TREATMENT Permit Number: BX7282IS Original Permit Number: -	EPR Reference: - Issue Date: 27/09/2022 Effective Date: 27/09/2022 Last date noted as effective: 25/05/2023 Status: Effective
C	498m W	Operator: AB InBev UK Ltd Installation Name: Magor Brewery EPR/BX7282IS Process: TREATMENT AND PROCESSING, OTHER THAN EXCLUSIVELY PACKAGING, OF THE FOLLOWING RAW MATERIALS, WHETHER PREVIOUSLY PROCESSED OR UNPROCESSED, INTENDED FOR THE PRODUCTION OF FOOD OR FEED (WHERE THE WEIGHT OF THE FINISHED PRODUCT EXCLUDES PACKAGING)—ONLY VEGETABLE RAW MATERIALS WITH A FINISHED PRODUCT PRODUCTION CAPACITY GREATER THAN 300 TONNES PER DAY OR 600 TONNES PER DAY WHERE THE INSTALLATION OPERATES FOR A PERIOD OF NO MORE THAN 90 CONSECUTIVE DAYS IN ANY YEAR Permit Number: BX7282IS Original Permit Number: -	EPR Reference: - Issue Date: 27/09/2022 Effective Date: 27/09/2022 Last date noted as effective: 25/05/2023 Status: Effective
C	498m W	Operator: AB InBev UK Ltd Installation Name: Magor Brewery EPR/BX7282IS Process: - Permit Number: BX7282IS Original Permit Number: -	EPR Reference: - Issue Date: 27/09/2022 Effective Date: 27/09/2022 Last date noted as effective: 25/05/2023 Status: Effective
C	498m W	Operator: AB INBEV UK LTD Installation Name: MAGOR BREWERY EPR/BX7282IS Process: - Permit Number: BX7282IS Original Permit Number: -	EPR Reference: - Issue Date: - Effective Date: - Last date noted as effective: 01/04/2017 Status: WITHDRAWN

ID	Location	Details	
C	498m W	Operator: AB INBEV UK LTD Installation Name: MAGOR BREWERY EPR/BX7282IS Process: TREATMENT AND PROCESSING, OTHER THAN EXCLUSIVELY PACKAGING, OF THE FOLLOWING RAW... Permit Number: BX7282IS Original Permit Number: MP3834EP	EPR Reference: - Issue Date: 23/09/2014 Effective Date: 23/09/2014 Last date noted as effective: 01/04/2018 Status: EFFECTIVE
C	498m W	Operator: INBEV UK LTD Installation Name: MAGOR BREWERY Process: ANIMAL VEGETABLE AND FOOD; TREATING ETC VEGETABLE RAW MATERIALS FOR FOOD >300T/D Permit Number: BX7282IS Original Permit Number: BX7282IS	EPR Reference: - Issue Date: 24/06/2005 Effective Date: 24/06/2005 Last date noted as effective: 17/11/2015 Status: SUPERCEDED
C	498m W	Operator: INBEV UK LTD Installation Name: MAGOR BREWERY EA/EPR/BX7282IS/V003 Process: ANIMAL VEGETABLE AND FOOD; TREATING ETC VEGETABLE RAW MATERIALS FOR FOOD >300T/D Permit Number: RP3831HS Original Permit Number: BX7282IS	EPR Reference: - Issue Date: 16/08/2011 Effective Date: 16/08/2011 Last date noted as effective: 17/11/2015 Status: SUPERCEDED
C	498m W	Operator: INBEV UK LTD Installation Name: MAGOR BREWERY Process: ANIMAL VEGETABLE AND FOOD; TREATING ETC VEGETABLE RAW MATERIALS FOR FOOD >300T/D Permit Number: VP3534LH Original Permit Number: BX7282IS	EPR Reference: - Issue Date: 16/06/2006 Effective Date: 16/06/2006 Last date noted as effective: 17/11/2015 Status: SUPERCEDED
C	498m W	Operator: AB INBEV UK LTD Installation Name: MAGOR BREWERY Process: CREATED BY IED - DISPOSAL OF > 50 T/D NON-HAZARDOUS WASTE (> 100 T/D IF ONLY AD) INVOLVING BIOLOGICAL TREATMENT Permit Number: KP3731ZF Original Permit Number: BX7282IS	EPR Reference: - Issue Date: 25/03/2013 Effective Date: 25/03/2013 Last date noted as effective: 01/07/2013 Status: EFFECTIVE
C	498m W	Operator: AB INBEV UK LTD Installation Name: MAGOR BREWERY EA/EPR/BX7282IS/V004 Process: ANIMAL VEGETABLE AND FOOD; TREATING ETC VEGETABLE RAW MATERIALS FOR FOOD >300T/D Permit Number: CP3438CC Original Permit Number: BX7282IS	EPR Reference: - Issue Date: 14/03/2012 Effective Date: 14/03/2012 Last date noted as effective: 17/11/2015 Status: SUPERCEDED
C	498m W	Operator: AB INBEV UK LTD Installation Name: MAGOR BREWERY EA/EPR/BX7282IS/V005 Process: ANIMAL VEGETABLE AND FOOD; TREATING ETC VEGETABLE RAW MATERIALS FOR FOOD >300T/D Permit Number: KP3731ZF Original Permit Number: BX7282IS	EPR Reference: - Issue Date: 25/03/2013 Effective Date: 25/03/2013 Last date noted as effective: 17/11/2015 Status: SUPERCEDED



ID	Location	Details	
C	498m W	Operator: AB INBEV UK LTD Installation Name: MAGOR BREWERY EA/EPR/BX7282IS/V005 Process: DISPOSAL OF > 50 T/D NON-HAZARDOUS WASTE (> 100 T/D IF ONLY AD) INVOLVING BIOLOGICAL TREATMENT Permit Number: KP3731ZF Original Permit Number: BX7282IS	EPR Reference: - Issue Date: 25/03/2013 Effective Date: 25/03/2013 Last date noted as effective: 17/11/2015 Status: SUPERCEDED
C	498m W	Operator: AB INBEV UK LTD Installation Name: MAGOR BREWERY EPR/BX7282IS Process: COMBUSTION; ANY FUEL =>50MW Permit Number: MP3834EP Original Permit Number: BX7282IS	EPR Reference: - Issue Date: 23/09/2014 Effective Date: 23/09/2014 Last date noted as effective: 17/11/2015 Status: EFFECTIVE
C	498m W	Operator: AB INBEV UK LTD Installation Name: MAGOR BREWERY EPR/BX7282IS Process: DISPOSAL OR RECOVERY OF HAZARDOUS WASTE WITH A CAPACITY EXCEEDING 10 TONNES PER DAY INVOLVING BIOLOGICAL TREATMENT Permit Number: MP3834EP Original Permit Number: BX7282IS	EPR Reference: - Issue Date: 23/09/2014 Effective Date: 23/09/2014 Last date noted as effective: 17/11/2015 Status: EFFECTIVE

This data is sourced from the Environment Agency and Natural Resources Wales.

## 4.11 Licensed pollutant release (Part A(2)/B)

Records within 500m

1

Records of Part A(2) and Part B installations regulated under the Environmental Permitting (England and Wales) Regulations 2016 for the release of substances to the environment.

Features are displayed on the Current industrial land use map on [page 32 >](#)

ID	Location	Address	Details	
A	145m NW	Magor Motorway Service Station, Junction 23, M4, Magor, Caldicot, Monmouthshire, NP6 3YL	Process: Unloading of Petrol into Storage at Service Stations Status: Current Permit Permit Type: Part B	Enforcement: No Enforcements Notified Date of enforcement: No Enforcements Notified Comment: No Enforcements Notified

This data is sourced from Local Authority records.





## 4.12 Radioactive Substance Authorisations

Records within 500m

0

Records of the storage, use, accumulation and disposal of radioactive substances regulated under the Radioactive Substances Act 1993.

*This data is sourced from the Environment Agency and Natural Resources Wales.*

## 4.13 Licensed Discharges to controlled waters

Records within 500m

4

Discharges of treated or untreated effluent to controlled waters under the Water Resources Act 1991.

Features are displayed on the Current industrial land use map on [page 32 >](#)

ID	Location	Address	Details	
B	152m E	Unknown Unknown Unknown Unknown Unk	Effluent Type: UNSPECIFIED Permit Number: AN0217401 Permit Version: 1 Receiving Water: MILL REEN	Status: REVOKED - UNSPECIFIED Issue date: 01/01/1901 Effective Date: 01/01/1901 Revocation Date: 30/08/1990
B	152m E	Unknown Unknown Unknown Unknown Unk	Effluent Type: UNSPECIFIED Permit Number: AN0217401 Permit Version: 2 Receiving Water: MILL REEN	Status: CONSENT EXPIRED - TIME LIMIT Issue date: 31/08/1990 Effective Date: 31/08/1990 Revocation Date: 19/04/1993
4	156m W	MAGOR MOTORWAY SERVICES M4 JUNCTION, MAGOR MOTORWAY SERVICES, M4 JUNCTION 23, MAGOR, MONMOUTHSHIRE	Effluent Type: SEWAGE DISCHARGES - SEWER STORM OVERFLOW - NOT WATER COMPANY Permit Number: AN0259201 Permit Version: 0 Receiving Water: ST BRIDES BROOK	Status: Effective Issue date: 20/07/1995 Effective Date: 20/07/1995 Revocation Date: -
6	244m SE	MAGOR - 1 WILLOW BROOK SYCAMORE TER, MAGOR - 1 WILLOW BROOK SYCAMORE, SYCAMORE TERRACE LANE	Effluent Type: UNSPECIFIED Permit Number: AN0145301 Permit Version: 1 Receiving Water: SOAKAWAY	Status: CONSENT EXPIRED - TIME LIMIT Issue date: 07/07/1989 Effective Date: 07/07/1989 Revocation Date: 06/10/1994

*This data is sourced from the Environment Agency and Natural Resources Wales.*



#### 4.14 Pollutant release to surface waters (Red List)

Records within 500m 0

Discharges of specified substances under the Environmental Protection (Prescribed Processes and Substances) Regulations 1991.

*This data is sourced from the Environment Agency and Natural Resources Wales.*

#### 4.15 Pollutant release to public sewer

Records within 500m 0

Discharges of Special Category Effluents to the public sewer.

*This data is sourced from the Environment Agency and Natural Resources Wales.*

#### 4.16 List 1 Dangerous Substances

Records within 500m 0

Discharges of substances identified on List I of European Directive E 2006/11/EC, and regulated under the Environmental Damage (Prevention and Remediation) Regulations 2015.

*This data is sourced from the Environment Agency and Natural Resources Wales.*

#### 4.17 List 2 Dangerous Substances

Records within 500m 0

Discharges of substances identified on List II of European Directive E 2006/11/EC, and regulated under the Environmental Damage (Prevention and Remediation) Regulations 2015.

*This data is sourced from the Environment Agency and Natural Resources Wales.*

#### 4.18 Pollution Incidents (EA/NRW)

Records within 500m 2

Records of substantiated pollution incidents. Since 2006 this data has only included category 1 (major) and 2 (significant) pollution incidents.

Features are displayed on the Current industrial land use map on [page 32 >](#)

ID	Location	Details	
2	47m S	Incident Date: 24/04/2001 Incident Identification: 3226 Pollutant: Pollutant Not Identified Pollutant Description: Not Identified	Water Impact: Category 4 (No Impact) Land Impact: Category 4 (No Impact) Air Impact: Category 4 (No Impact)
A	141m NW	Incident Date: 30/06/2015 Incident Identification: 1349924 Pollutant: Organic Chemicals/Products Pollutant Description: Other Organic Chemical or Product	Water Impact: - Land Impact: Category 4 (No Impact) Air Impact: Category 4 (No Impact)

*This data is sourced from the Environment Agency and Natural Resources Wales.*

### 4.19 Pollution inventory substances

<b>Records within 500m</b>	<b>0</b>
----------------------------	----------

The pollution inventory (substances) includes reporting on annual emissions of certain regulated substances to air, controlled waters and land. A reporting threshold for each substance is also included. Where emissions fall below the reporting threshold, no value will be given. The data is given for the most recent complete year available.

*This data is sourced from the Environment Agency and the Scottish Environment Protection Agency.*

### 4.20 Pollution inventory waste transfers

<b>Records within 500m</b>	<b>0</b>
----------------------------	----------

The pollution inventory (waste transfers) includes reporting on annual transfers and recovery/disposal of controlled wastes from a site. A reporting threshold for each waste type is also included. Where releases fall below the reporting threshold, no value will be given. The data is given for the most recent complete year available.

*This data is sourced from the Environment Agency and the Scottish Environment Protection Agency.*

### 4.21 Pollution inventory radioactive waste

<b>Records within 500m</b>	<b>0</b>
----------------------------	----------

The pollution inventory (radioactive wastes) includes reporting on annual releases of radioactive substances from a site, including the means of release. Where releases fall below the reporting threshold, no value will be given. The data is given for the most recent complete year available.

*This data is sourced from the Environment Agency and the Scottish Environment Protection Agency.*

## 5 Hydrogeology - Superficial aquifer

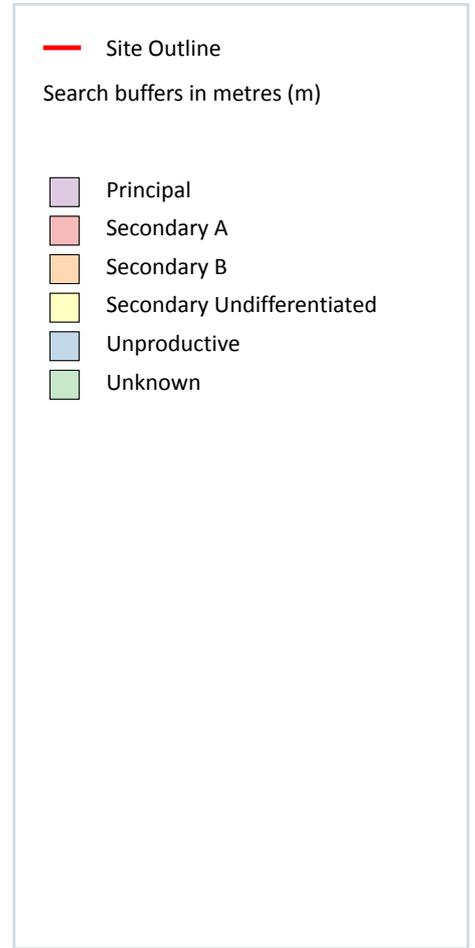
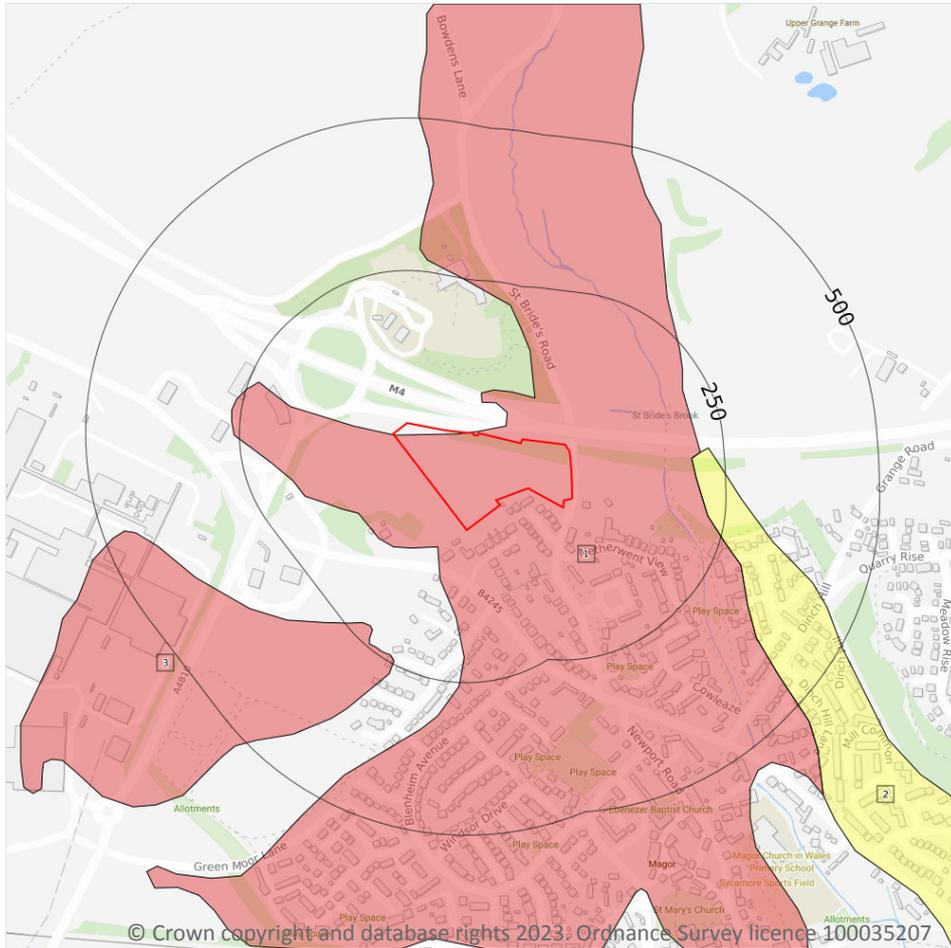

### 5.1 Superficial aquifer

Records within 500m

3

Aquifer status of groundwater held within superficial geology.

Features are displayed on the Hydrogeology map on [page 41](#) >

ID	Location	Designation	Description
1	On site	Secondary A	Permeable layers capable of supporting water supplies at a local rather than strategic scale, and in some cases forming an important source of base flow to rivers. These are generally aquifers formerly classified as minor aquifers
2	197m E	Secondary Undifferentiated	Assigned where it is not possible to attribute either category A or B to a rock type. In general these layers have previously been designated as both minor and non-aquifer in different locations due to the variable characteristics of the rock type

ID	Location	Designation	Description
3	222m SW	Secondary A	Permeable layers capable of supporting water supplies at a local rather than strategic scale, and in some cases forming an important source of base flow to rivers. These are generally aquifers formerly classified as minor aquifers

*This data is sourced from the British Geological Survey, the Environment Agency and Natural Resources Wales.*

## Bedrock aquifer

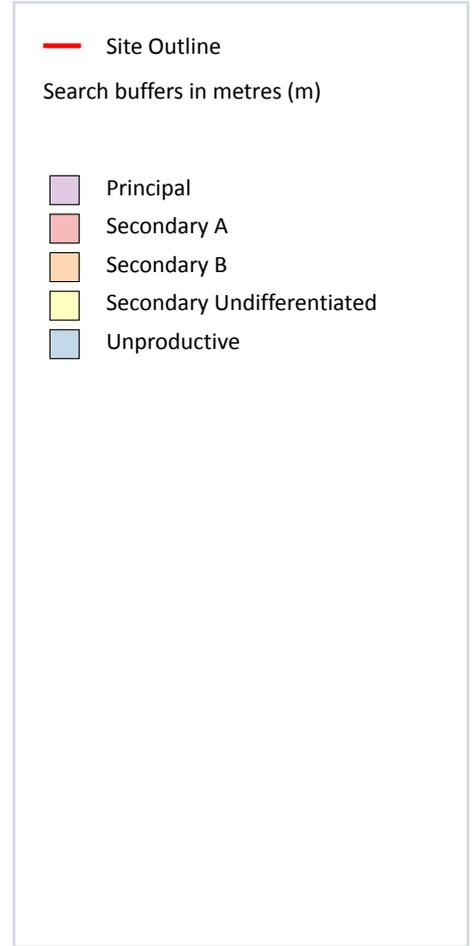
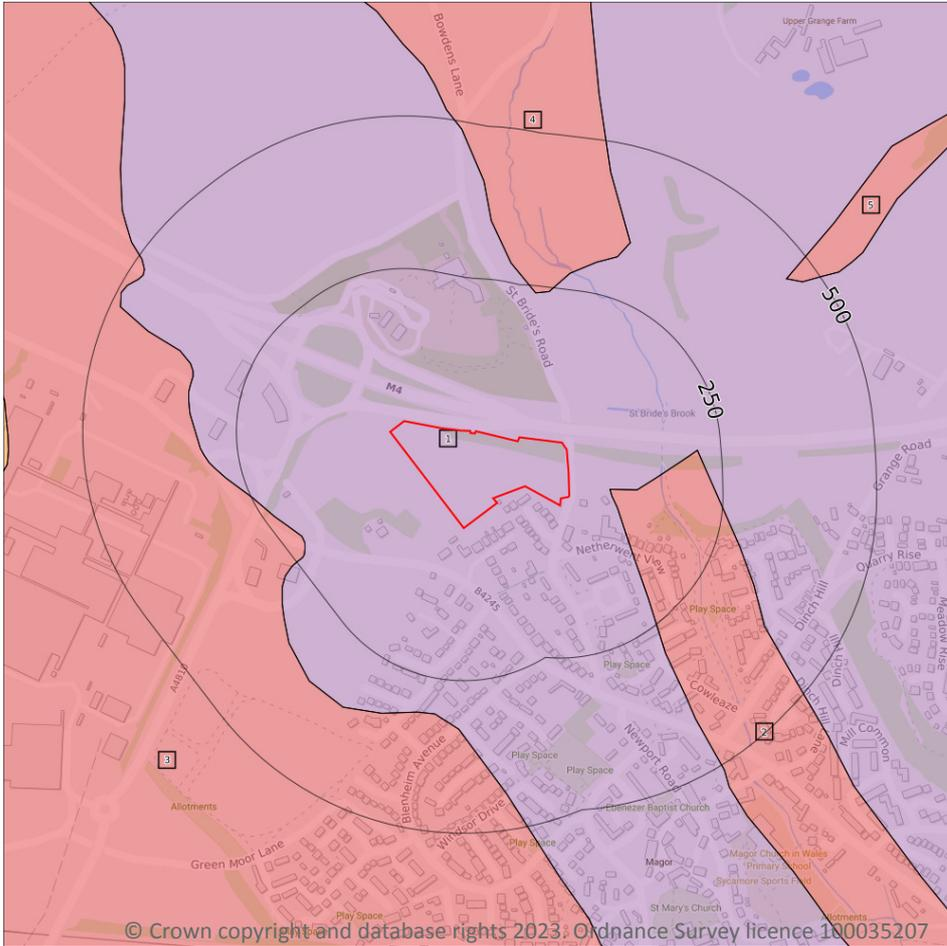

### 5.2 Bedrock aquifer

Records within 500m

5

Aquifer status of groundwater held within bedrock geology.

Features are displayed on the Bedrock aquifer map on [page 43](#) >

ID	Location	Designation	Description
1	On site	Principal	<b>Geology of high intergranular and/or fracture permeability, usually providing a high level of water storage and may support water supply/river base flow on a strategic scale. Generally principal aquifers were previously major aquifers</b>
2	67m E	Secondary A	Permeable layers capable of supporting water supplies at a local rather than strategic scale, and in some cases forming an important source of base flow to rivers. These are generally aquifers formerly classified as minor aquifers

ID	Location	Designation	Description
3	218m W	Secondary A	Permeable layers capable of supporting water supplies at a local rather than strategic scale, and in some cases forming an important source of base flow to rivers. These are generally aquifers formerly classified as minor aquifers
4	238m N	Secondary A	Permeable layers capable of supporting water supplies at a local rather than strategic scale, and in some cases forming an important source of base flow to rivers. These are generally aquifers formerly classified as minor aquifers
5	453m NE	Secondary A	Permeable layers capable of supporting water supplies at a local rather than strategic scale, and in some cases forming an important source of base flow to rivers. These are generally aquifers formerly classified as minor aquifers

*This data is sourced from the British Geological Survey, the Environment Agency and Natural Resources Wales.*

## Groundwater vulnerability

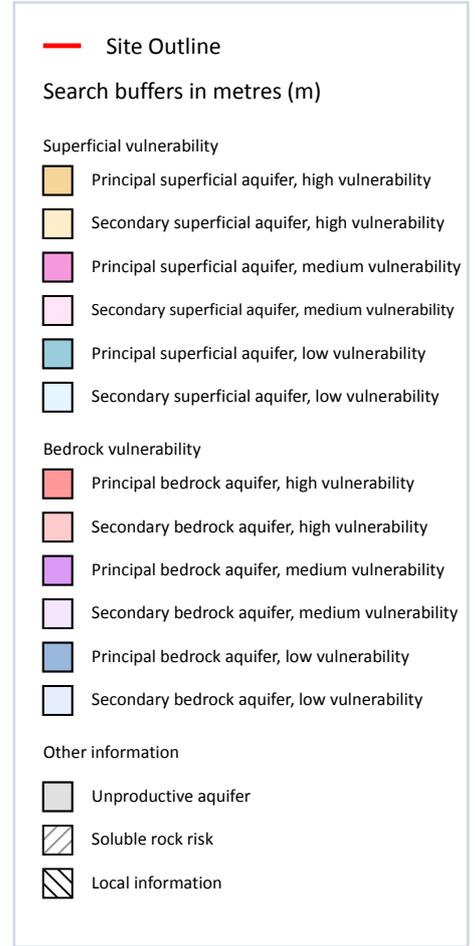
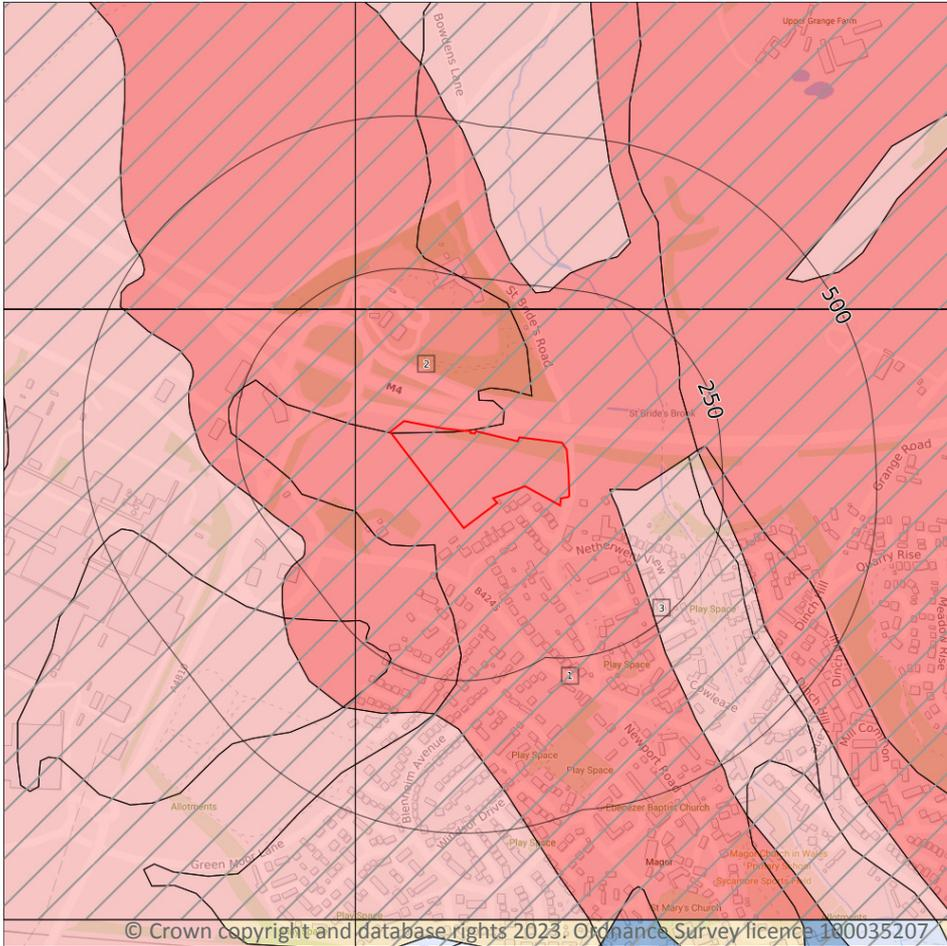

### 5.3 Groundwater vulnerability

Records within 50m

2

An assessment of the vulnerability of groundwater to a pollutant discharged at ground level based on the hydrological, geological, hydrogeological and soil properties within a one kilometre square grid. Groundwater vulnerability is described as High, Medium or Low as follows:

- High - Areas able to easily transmit pollution to groundwater. They are likely to be characterised by high leaching soils and the absence of low permeability superficial deposits.
- Medium - Intermediate between high and low vulnerability.
- Low - Areas that provide the greatest protection from pollution. They are likely to be characterised by low leaching soils and/or the presence of superficial deposits characterised by a low permeability.

Features are displayed on the Groundwater vulnerability map on [page 45 >](#)



ID	Location	Summary	Soil / surface	Superficial geology	Bedrock geology
1	On site	<b>Summary Classification:</b> Principal bedrock aquifer - High Vulnerability <b>Combined classification:</b> Productive Bedrock Aquifer, Productive Superficial Aquifer	<b>Leaching class:</b> Intermediate <b>Infiltration value:</b> >70% <b>Dilution value:</b> 300-550mm/year	<b>Vulnerability:</b> Medium <b>Aquifer type:</b> Secondary <b>Thickness:</b> <3m <b>Patchiness value:</b> <90% <b>Recharge potential:</b> No Data	<b>Vulnerability:</b> High <b>Aquifer type:</b> Principal <b>Flow mechanism:</b> Well connected fractures
2	On site	<b>Summary Classification:</b> Principal bedrock aquifer - High Vulnerability <b>Combined classification:</b> Productive Bedrock Aquifer, No Superficial Aquifer	<b>Leaching class:</b> Intermediate <b>Infiltration value:</b> >70% <b>Dilution value:</b> 300-550mm/year	<b>Vulnerability:</b> - <b>Aquifer type:</b> - <b>Thickness:</b> <3m <b>Patchiness value:</b> <90% <b>Recharge potential:</b> No Data	<b>Vulnerability:</b> High <b>Aquifer type:</b> Principal <b>Flow mechanism:</b> Well connected fractures

This data is sourced from the British Geological Survey, the Environment Agency and Natural Resources Wales.

## 5.4 Groundwater vulnerability- soluble rock risk

<b>Records on site</b>	<b>1</b>
------------------------	----------

This dataset identifies areas where solution features that enable rapid movement of a pollutant may be present within a 1km grid square.

ID	Maximum soluble risk category	Percentage of grid square covered by maximum risk
3	<b>Very significant soluble rocks are likely to be present with a high possibility of localised subsidence or dissolution-related degradation of bedrock occurring naturally, especially in adverse conditions such as concentrated surface or subsurface water flow.</b>	0.0%

This data is sourced from the British Geological Survey and the Environment Agency.

## 5.5 Groundwater vulnerability- local information

<b>Records on site</b>	<b>0</b>
------------------------	----------

This dataset identifies areas where additional local information affecting vulnerability is held by the Environment Agency. Further information can be obtained by contacting the Environment Agency local Area groundwater team through the Environment Agency National Customer Call Centre on 03798 506 506 or by email on [enquiries@environment-agency.gov.uk](mailto:enquiries@environment-agency.gov.uk) ↗.

This data is sourced from the British Geological Survey and the Environment Agency.

## Abstractions and Source Protection Zones

### 5.6 Groundwater abstractions

Records within 2000m

0

Licensed groundwater abstractions for sites extracting more than 20 cubic metres of water a day and includes active and historical records. The data may be for a single abstraction point, between two points (line data) or a larger area.

*This data is sourced from the Environment Agency and Natural Resources Wales.*

### 5.7 Surface water abstractions

Records within 2000m

0

Licensed surface water abstractions for sites extracting more than 20 cubic metres of water a day and includes active and historical records. The data may be for a single abstraction point, a stretch of watercourse or a larger area.

*This data is sourced from the Environment Agency and Natural Resources Wales.*

### 5.8 Potable abstractions

Records within 2000m

0

Licensed potable water abstractions for sites extracting more than 20 cubic metres of water a day and includes active and historical records. The data may be for a single abstraction point, a stretch of watercourse or a larger area.

*This data is sourced from the Environment Agency and Natural Resources Wales.*

### 5.9 Source Protection Zones

Records within 500m

0

Source Protection Zones define the sensitivity of an area around a potable abstraction site to contamination.

*This data is sourced from the Environment Agency and Natural Resources Wales.*

## 5.10 Source Protection Zones (confined aquifer)

Records within 500m

0

Source Protection Zones in the confined aquifer define the sensitivity around a deep groundwater abstraction to contamination. A confined aquifer would normally be protected from contamination by overlying geology and is only considered a sensitive resource if deep excavation/drilling is taking place.

*This data is sourced from the Environment Agency and Natural Resources Wales.*



## 6 Hydrology

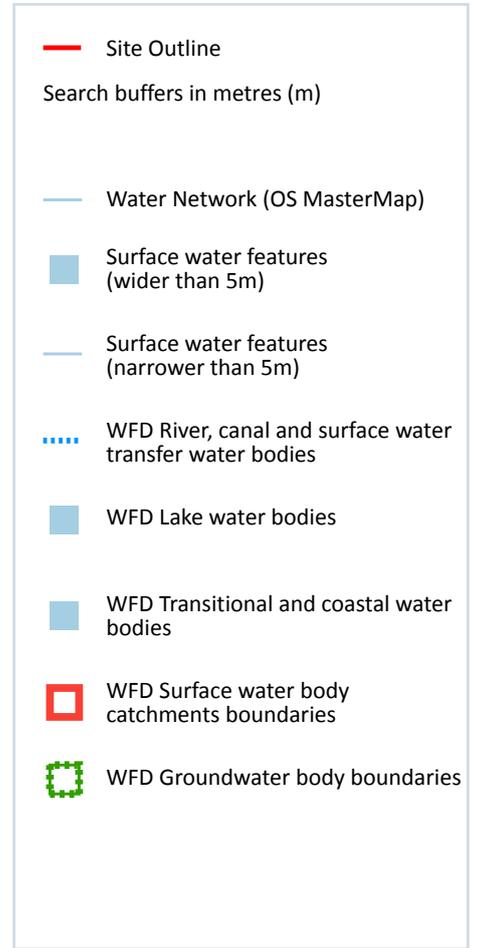
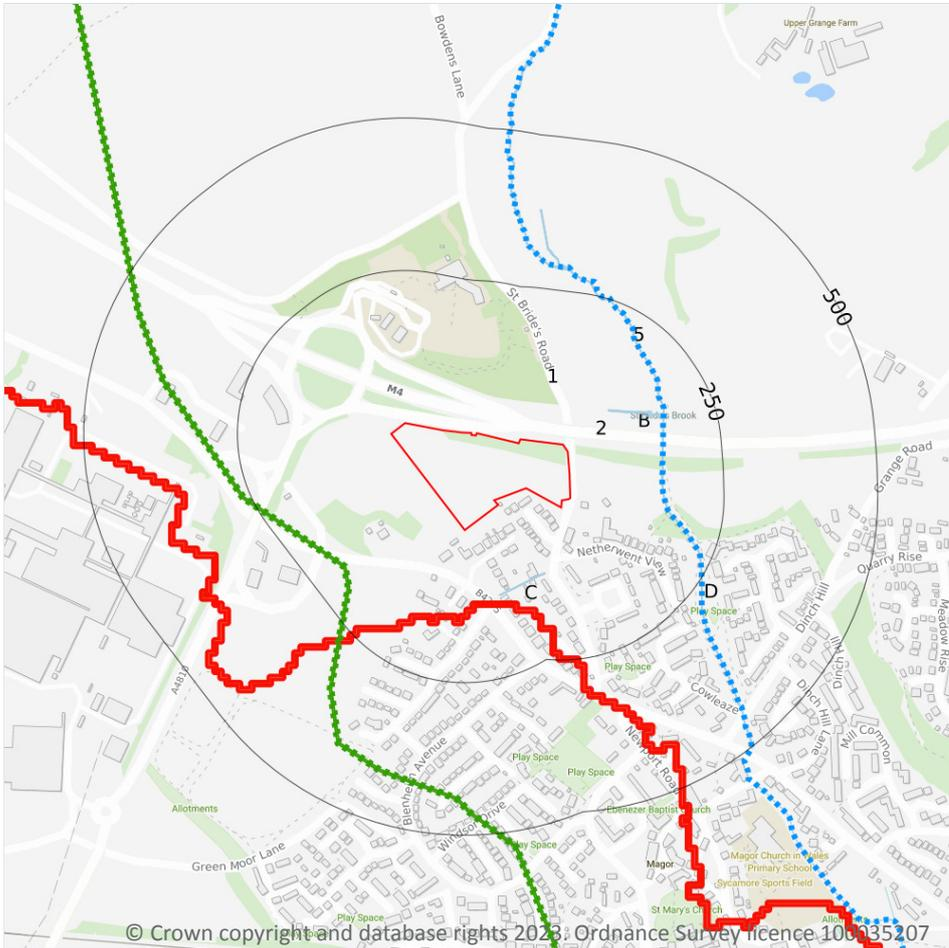

### 6.1 Water Network (OS MasterMap)

Records within 250m

6

Detailed water network of Great Britain showing the flow and precise central course of every river, stream, lake and canal.

Features are displayed on the Hydrology map on [page 49 >](#)

ID	Location	Type of water feature	Ground level	Permanence	Name
B	92m NE	Inland river not influenced by normal tidal action.	On ground surface	Watercourse contains water year round (in normal circumstances)	-

ID	Location	Type of water feature	Ground level	Permanence	Name
C	110m SE	Inland river not influenced by normal tidal action.	On ground surface	Watercourse contains water year round (in normal circumstances)	-
D	150m E	Inland river not influenced by normal tidal action.	On ground surface	Watercourse contains water year round (in normal circumstances)	St Bride's Brook
B	152m E	Inland river not influenced by normal tidal action.	Underground	Watercourse contains water year round (in normal circumstances)	St Bride's Brook
B	161m E	Inland river not influenced by normal tidal action.	On ground surface	Watercourse contains water year round (in normal circumstances)	St Bride's Brook
5	166m E	Inland river not influenced by normal tidal action.	On ground surface	Watercourse contains water year round (in normal circumstances)	St Bride's Brook

*This data is sourced from the Ordnance Survey.*

## 6.2 Surface water features

**Records within 250m**

**3**

Covering rivers, streams and lakes (some overlap with OS MasterMap Water Network data in previous section) but additionally covers smaller features such as ponds. Rivers and streams narrower than 5m are represented as a single line. Lakes, ponds and rivers or streams wider than 5m are represented as polygons.

Features are displayed on the Hydrology map on [page 49 >](#)

*This data is sourced from the Ordnance Survey.*

## 6.3 WFD Surface water body catchments

**Records on site**

**1**

The Water Framework Directive is an EU-led framework for the protection of inland surface waters, estuaries, coastal waters and groundwater through river basin-level management planning. In terms of surface water, these basins are broken down into smaller units known as management, operational and water body catchments.

Features are displayed on the Hydrology map on [page 49 >](#)

ID	Location	Type	Water body catchment	Water body ID	Operational catchment	Management catchment
1	On site	River WB catchment	Mill Reen - source to R Severn Estuary	GB109056026860	East Reens	Usk

This data is sourced from the Environment Agency and Natural Resources Wales.

## 6.4 WFD Surface water bodies

<b>Records identified</b>	<b>1</b>
---------------------------	----------

Surface water bodies under the Directive may be rivers, lakes, estuary or coastal. To achieve the purpose of the Directive, environmental objectives have been set and are reported on for each water body. The progress towards delivery of the objectives is then reported on by the relevant competent authorities at the end of each six-year cycle. The river water body directly associated with the catchment listed in the previous section is detailed below, along with any lake, canal, coastal or artificial water body within 250m of the site.

Features are displayed on the Hydrology map on [page 49 >](#)

ID	Location	Type	Name	Water body ID	Overall rating	Chemical rating	Ecological rating	Year
4	150m E	River	Mill Reen - source to R Severn Estuary	GB109056026860	Moderate	Good	Moderate	2016

This data is sourced from the Environment Agency and Natural Resources Wales.

## 6.5 WFD Groundwater bodies

<b>Records on site</b>	<b>1</b>
------------------------	----------

Groundwater bodies are also covered by the Directive and the same regime of objectives and reporting detailed in the previous section is in place.

Features are displayed on the Hydrology map on [page 49 >](#)

ID	Location	Name	Water body ID	Overall rating	Chemical rating	Quantitative	Year
2	On site	Usk and Wye Southern Carboniferous Limestone	GB40901G206300	Good	Good	Good	2017

This data is sourced from the Environment Agency and Natural Resources Wales.



## 7 River and coastal flooding

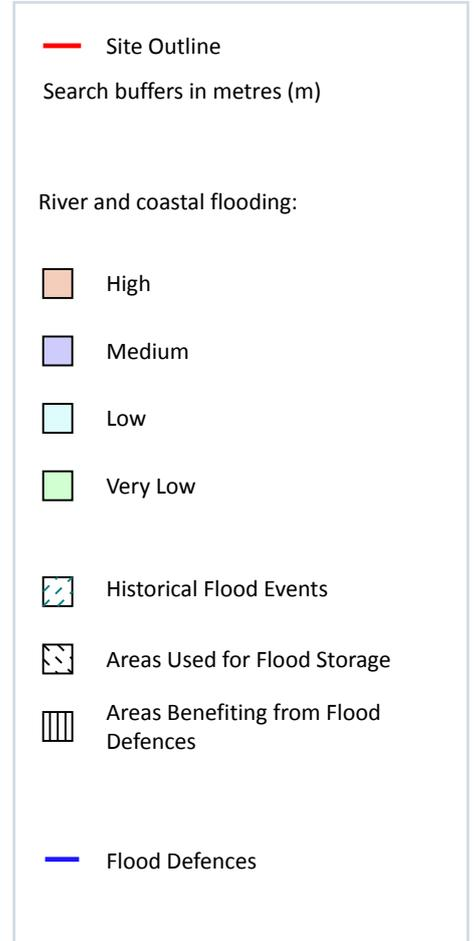
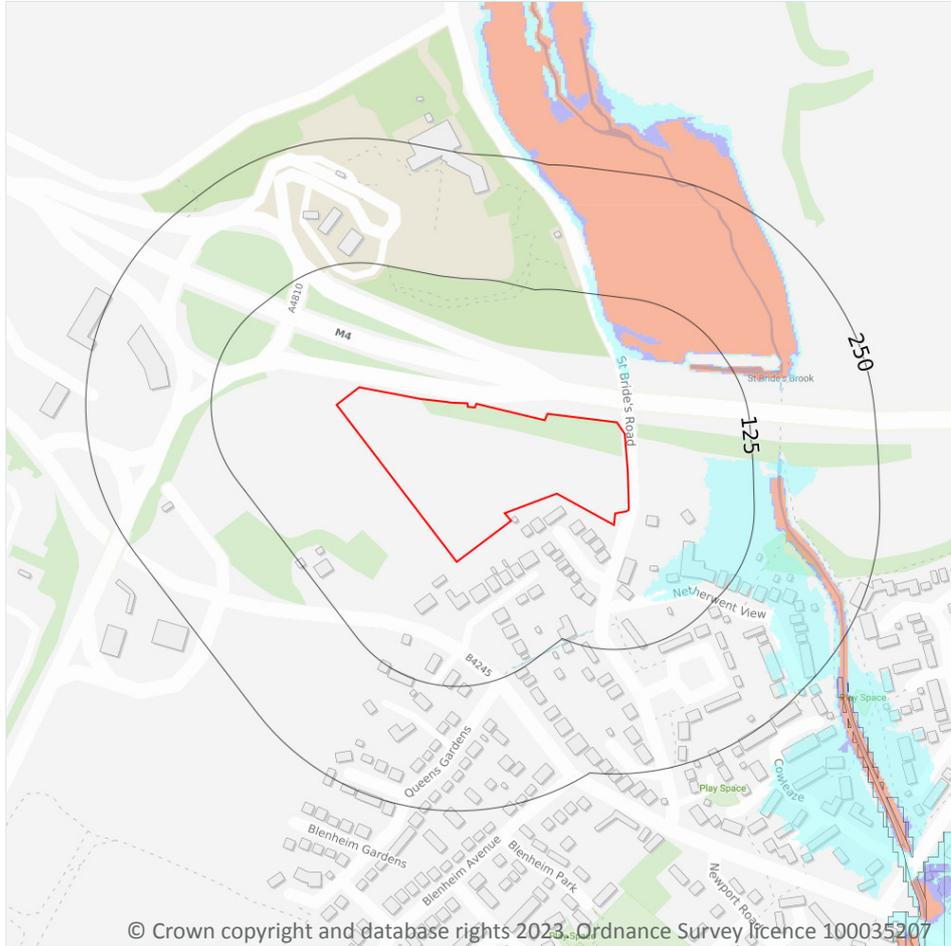

### 7.1 Risk of flooding from rivers and the sea

#### Records within 50m

1

The chance of flooding from rivers and/or the sea in any given year, based on cells of 50m within the Risk of Flooding from Rivers and Sea (RoFRaS)/Flood Risk Assessment Wales (FRAW) models. Each cell is allocated one of four flood risk categories, taking into account flood defences and their condition. The risk categories for RoFRaS for rivers and the sea and FRAW for rivers are; Very low (less than 1 in 1000 chance in any given year), Low (less than 1 in 100 but greater than or equal to 1 in 1000 chance), Medium (less than 1 in 30 but greater than or equal to 1 in 100 chance) or High (greater than or equal to 1 in 30 chance). The risk categories for FRAW for the sea are; Very low (less than 1 in 1000 chance in any given year), Low (less than 1 in 200 but greater than or equal to 1 in 1000 chance), Medium (less than 1 in 30 but greater than or equal to 1 in 200 chance) or High (greater than or equal to 1 in 30 chance).

Features are displayed on the River and coastal flooding map on [page 52 >](#)

Distance	Flood risk category
<b>On site</b>	<b>N/A</b>
0 - 50m	Low

*This data is sourced from the Environment Agency and Natural Resources Wales.*

## 7.2 Historical Flood Events

<b>Records within 250m</b>	<b>0</b>
----------------------------	----------

Records of historic flooding from rivers, the sea, groundwater and surface water. Records began in 1946 when predecessor bodies started collecting detailed information about flooding incidents, although limited details may be included on flooding incidents prior to this date. Takes into account the presence of defences, structures, and other infrastructure where they existed at the time of flooding, and includes flood extents that may have been affected by overtopping, breaches or blockages.

*This data is sourced from the Environment Agency and Natural Resources Wales.*

## 7.3 Flood Defences

<b>Records within 250m</b>	<b>0</b>
----------------------------	----------

Records of flood defences owned, managed or inspected by the Environment Agency and Natural Resources Wales. Flood defences can be structures, buildings or parts of buildings. Typically these are earth banks, stone and concrete walls, or sheet-piling that is used to prevent or control the extent of flooding.

*This data is sourced from the Environment Agency and Natural Resources Wales.*

## 7.4 Areas Benefiting from Flood Defences

<b>Records within 250m</b>	<b>0</b>
----------------------------	----------

Areas that would benefit from the presence of flood defences in a 1 in 100 (1%) chance of flooding each year from rivers or 1 in 200 (0.5%) chance of flooding each year from the sea.

*This data is sourced from the Environment Agency and Natural Resources Wales.*

## 7.5 Flood Storage Areas

<b>Records within 250m</b>	<b>0</b>
----------------------------	----------

Areas that act as a balancing reservoir, storage basin or balancing pond to attenuate an incoming flood peak to a flow level that can be accepted by the downstream channel or to delay the timing of a flood peak so that its volume is discharged over a longer period.

*This data is sourced from the Environment Agency and Natural Resources Wales.*





## River and coastal flooding - Flood Zones

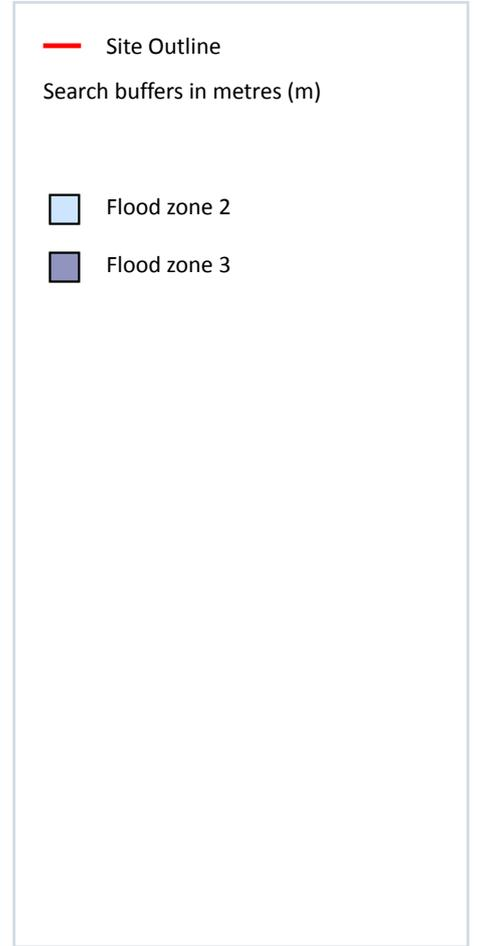

### 7.6 Flood Zone 2

#### Records within 50m

1

Areas of land at risk of flooding, when the presence of flood defences are ignored. Covering land between Flood Zone 3 (see next section) and the extent of the flooding from rivers or the sea with a 1 in 1000 (0.1%) chance of flooding each year.

Features are displayed on the River and coastal flooding map on [page 52 >](#)

Location	Type
35m NE	Zone 2 - (Fluvial /Tidal Models)

*This data is sourced from the Environment Agency and Natural Resources Wales.*

## 7.7 Flood Zone 3

### Records within 50m

**1**

Areas of land at risk of flooding, when the presence of flood defences are ignored. Covering land with a 1 in 100 (1%) or greater chance of flooding each year from rivers or a 1 in 200 (0.5%) or greater chance of flooding each year from the sea.

Features are displayed on the River and coastal flooding map on [page 52 >](#)

Location	Type
39m NE	Zone 3 - (Fluvial /Tidal Models)

*This data is sourced from the Environment Agency and Natural Resources Wales.*

## 8 Surface water flooding

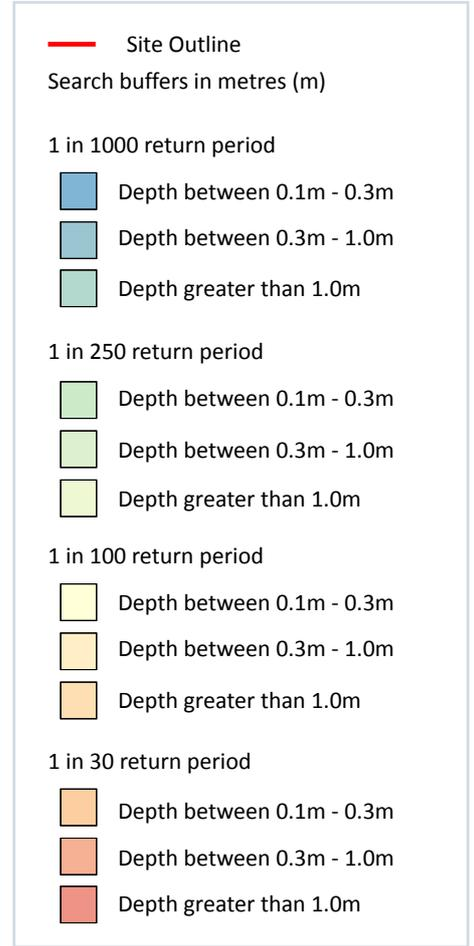

### 8.1 Surface water flooding

Highest risk on site

1 in 1000 year, 0.3m - 1.0m

Highest risk within 50m

1 in 30 year, 0.3m - 1.0m

Ambiental Risk Analytics surface water (pluvial) FloodMap identifies areas likely to flood as a result of extreme rainfall events, i.e. land naturally vulnerable to surface water ponding or flooding. This data set was produced by simulating 1 in 30 year, 1 in 100 year, 1 in 250 year and 1 in 1,000 year rainfall events. Modern urban drainage systems are typically built to cope with rainfall events between 1 in 20 and 1 in 30 years, though some older ones may flood in a 1 in 5 year rainfall event.

Features are displayed on the Surface water flooding map on [page 56 >](#)

The data shown on the map and in the table above shows the highest likelihood of flood events happening at the site. Lower likelihood events may have greater flood depths and hence a greater potential impact on a site.

The table below shows the maximum flood depths for a range of return periods for the site.

Return period	Maximum modelled depth
1 in 1000 year	Between 0.3m and 1.0m
1 in 250 year	Negligible
1 in 100 year	Negligible
1 in 30 year	Negligible

*This data is sourced from Ambiental Risk Analytics.*

## 9 Groundwater flooding

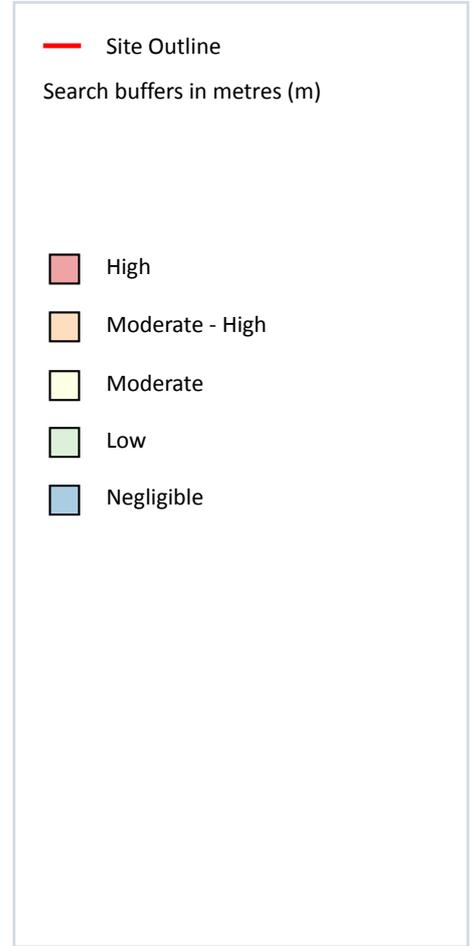
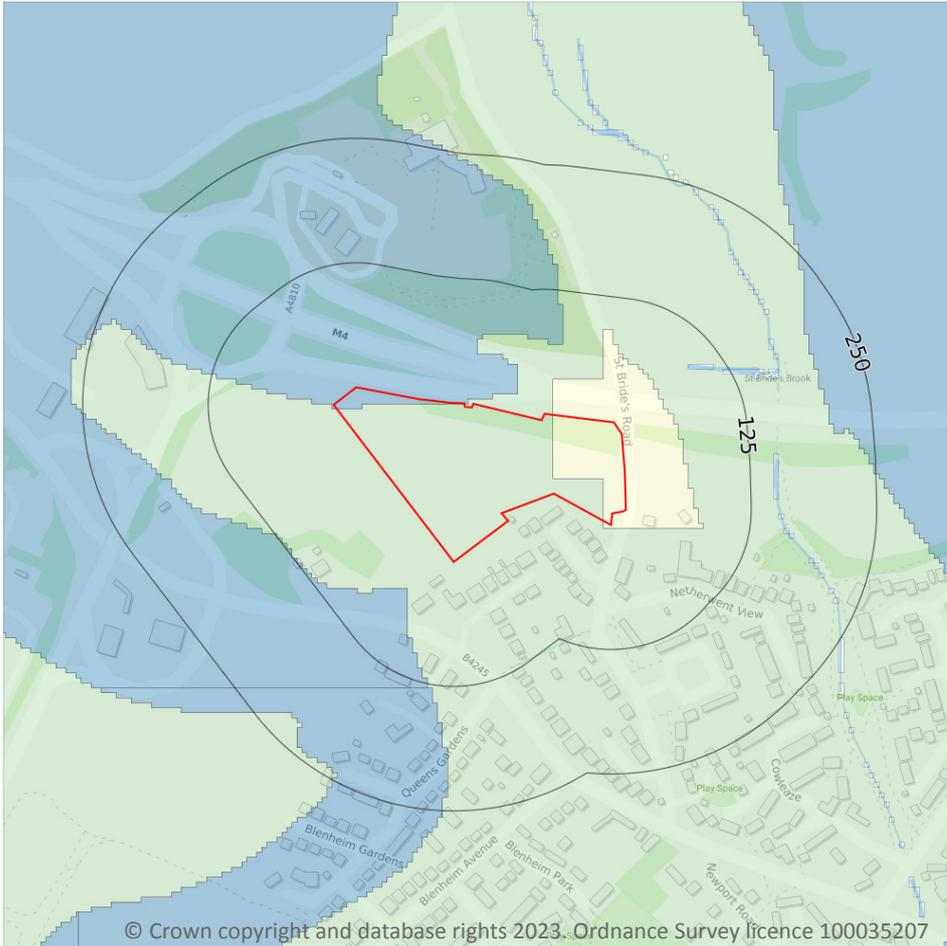

### 9.1 Groundwater flooding

**Highest risk on site**

**Moderate**

**Highest risk within 50m**

**Moderate**

Groundwater flooding is caused by unusually high groundwater levels. It occurs when the water table rises above the ground surface or within underground structures such as basements or cellars. Groundwater flooding tends to exhibit a longer duration than surface water flooding, possibly lasting for weeks or months, and as a result it can cause significant damage to property. This risk assessment is based on a 1 in 100 year return period and a 5m Digital Terrain Model (DTM).

Features are displayed on the Groundwater flooding map on [page 58 >](#)

*This data is sourced from Ambiental Risk Analytics.*

## 10 Environmental designations

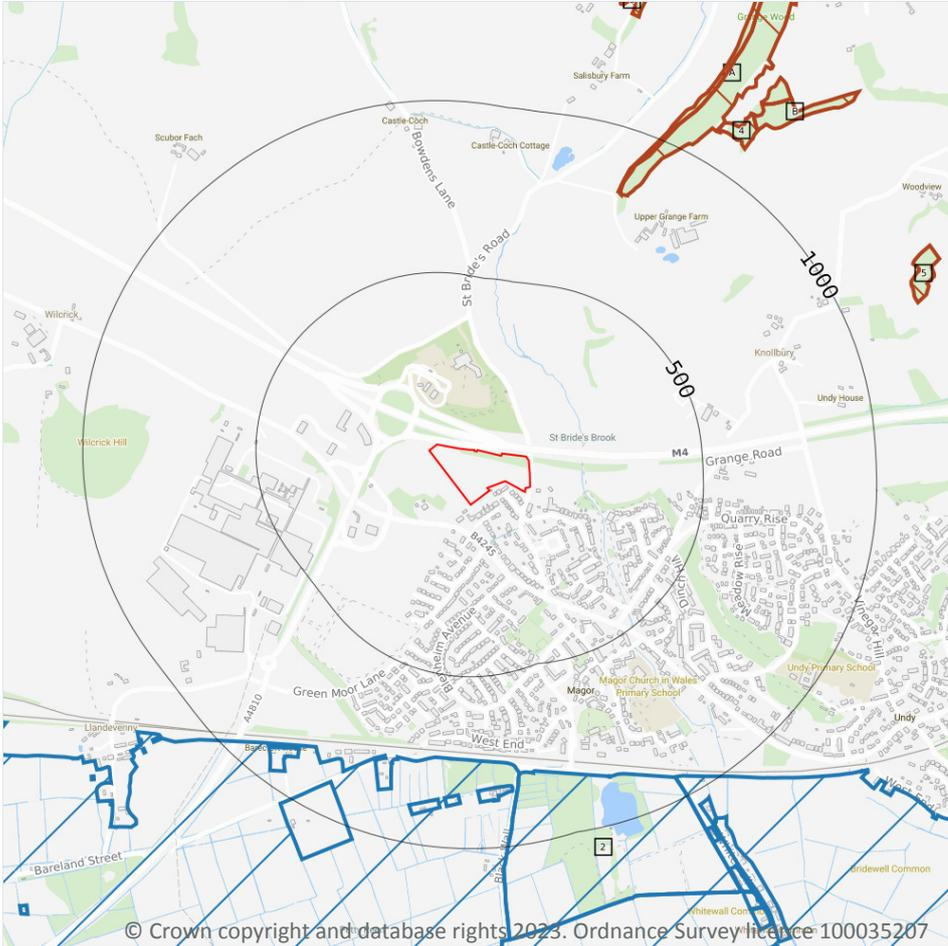

- Site Outline
- Search buffers in metres (m)
- Sites of Special Scientific Interest (SSSI)
- X National Nature Reserves (NNR)
- / Designated Ancient Woodland

### 10.1 Sites of Special Scientific Interest (SSSI)

Records within 2000m

5

Sites providing statutory protection for the best examples of UK flora, fauna, or geological or physiographical features. Originally notified under the National Parks and Access to the Countryside Act 1949, SSSIs were re-notified under the Wildlife and Countryside Act 1981. Improved provisions for the protection and management of SSSIs were introduced by the Countryside and Rights of Way Act 2000 (in England and Wales) and (in Scotland) by the Nature Conservation (Scotland) Act 2004 and the Wildlife and Natural Environment (Scotland) Act 2010.

Features are displayed on the Environmental designations map on [page 59 >](#)

ID	Location	Name	Data source
1	740m S	Gwent Levels - Redwick and Llandeveynny	Natural Resources Wales



ID	Location	Name	Data source
2	793m S	Magor Marsh	Natural Resources Wales
3	935m SE	Gwent Levels - Magor and Undy	Natural Resources Wales
-	1659m N	Penhow Woodlands	Natural Resources Wales
-	1910m N	Penhow Woodlands	Natural Resources Wales

*This data is sourced from Natural England, Natural Resources Wales and Scottish Natural Heritage.*

## 10.2 Conserved wetland sites (Ramsar sites)

**Records within 2000m**

**0**

Ramsar sites are designated under the Convention on Wetlands of International Importance, agreed in Ramsar, Iran, in 1971. They cover all aspects of wetland conservation and wise use, recognizing wetlands as ecosystems that are extremely important for biodiversity conservation in general and for the well-being of human communities. These sites cover a broad definition of wetland; marsh, fen, peatland or water, whether natural or artificial, permanent or temporary, with water that is static or flowing, fresh, brackish or salt, and even some marine areas.

*This data is sourced from Natural England, Natural Resources Wales and Scottish Natural Heritage.*

## 10.3 Special Areas of Conservation (SAC)

**Records within 2000m**

**0**

Areas which have been identified as best representing the range and variety within the European Union of habitats and (non-bird) species listed on Annexes I and II to the Directive. SACs are designated under the EC Habitats Directive.

*This data is sourced from Natural England, Natural Resources Wales and Scottish Natural Heritage.*

## 10.4 Special Protection Areas (SPA)

**Records within 2000m**

**0**

Sites classified by the UK Government under the EC Birds Directive, SPAs are areas of the most important habitat for rare (listed on Annex I to the Directive) and migratory birds within the European Union.

*This data is sourced from Natural England, Natural Resources Wales and Scottish Natural Heritage.*

## 10.5 National Nature Reserves (NNR)

Records within 2000m

1

Sites containing examples of some of the most important natural and semi-natural terrestrial and coastal ecosystems in Great Britain. They are managed to conserve their habitats, provide special opportunities for scientific study or to provide public recreation compatible with natural heritage interests.

Features are displayed on the Environmental designations map on [page 59 >](#)

ID	Location	Name	Data source
-	1910m N	Penhow Woodlands	Natural Resources Wales

*This data is sourced from Natural England, Natural Resources Wales and Scottish Natural Heritage.*

## 10.6 Local Nature Reserves (LNR)

Records within 2000m

0

Sites managed for nature conservation, and to provide opportunities for research and education, or simply enjoying and having contact with nature. They are declared by local authorities under the National Parks and Access to the Countryside Act 1949 after consultation with the relevant statutory nature conservation agency.

*This data is sourced from Natural England, Natural Resources Wales and Scottish Natural Heritage.*

## 10.7 Designated Ancient Woodland

Records within 2000m

16

Ancient woodlands are classified as areas which have been wooded continuously since at least 1600 AD. This includes semi-natural woodland and plantations on ancient woodland sites. 'Wooded continuously' does not mean there is or has previously been continuous tree cover across the whole site, and not all trees within the woodland have to be old.

Features are displayed on the Environmental designations map on [page 59 >](#)

ID	Location	Name	Woodland Type
A	810m NE	Unknown	Ancient Semi Natural Woodland
A	810m NE	Unknown	Ancient Semi Natural Woodland
4	1094m NE	Unknown	Ancient Semi Natural Woodland
B	1158m NE	Unknown	Ancient Semi Natural Woodland
5	1211m E	Unknown	Ancient Semi Natural Woodland
B	1230m NE	Unknown	Ancient Semi Natural Woodland



ID	Location	Name	Woodland Type
6	1320m N	Unknown	Ancient Semi Natural Woodland
-	1348m W	Unknown	Ancient Semi Natural Woodland
-	1400m N	Unknown	Ancient Semi Natural Woodland
-	1602m NE	Unknown	Ancient Semi Natural Woodland
-	1613m NE	Unknown	Restored Ancient Woodland Site
-	1648m N	Unknown	Ancient Semi Natural Woodland
-	1662m N	Unknown	Ancient Semi Natural Woodland
-	1789m N	Unknown	Ancient Semi Natural Woodland
-	1790m N	Unknown	Ancient Semi Natural Woodland
-	1913m N	Unknown	Ancient Semi Natural Woodland

*This data is sourced from Natural England, Natural Resources Wales and Scottish Natural Heritage.*

## 10.8 Biosphere Reserves

**Records within 2000m**

**0**

Biosphere Reserves are internationally recognised by UNESCO as sites of excellence to balance conservation and socioeconomic development between nature and people. They are recognised under the Man and the Biosphere (MAB) Programme with the aim of promoting sustainable development founded on the work of the local community.

*This data is sourced from Natural England, Natural Resources Wales and Scottish Natural Heritage.*

## 10.9 Forest Parks

**Records within 2000m**

**0**

These are areas managed by the Forestry Commission designated on the basis of recreational, conservation or scenic interest.

*This data is sourced from the Forestry Commission.*

## 10.10 Marine Conservation Zones

Records within 2000m

0

A type of marine nature reserve in UK waters established under the Marine and Coastal Access Act (2009). They are designated with the aim to protect nationally important, rare or threatened habitats and species.

*This data is sourced from Natural England, Natural Resources Wales and Scottish Natural Heritage.*

## 10.11 Green Belt

Records within 2000m

0

Areas designated to prevent urban sprawl by keeping land permanently open.

*This data is sourced from the Ministry of Housing, Communities and Local Government.*

## 10.12 Proposed Ramsar sites

Records within 2000m

0

Ramsar sites are areas listed as a Wetland of International Importance under the Convention on Wetlands of International Importance especially as Waterfowl Habitat (the Ramsar Convention) 1971. The sites here supplied have a status of 'Proposed' having been identified for potential adoption under the framework.

*This data is sourced from Natural England.*

## 10.13 Possible Special Areas of Conservation (pSAC)

Records within 2000m

0

Special Areas of Conservation are areas which have been identified as best representing the range and variety within the European Union of habitats and (non-bird) species listed on Annexes I and II to the Directive. SACs are designated under the EC Habitats Directive. Those sites supplied here are those with a status of 'Possible' having been identified for potential adoption under the framework.

*This data is sourced from Natural England and Natural Resources Wales.*

## 10.14 Potential Special Protection Areas (pSPA)

Records within 2000m

0

Special Protection Areas (SPAs) are areas designated (or 'classified') under the European Union Wild Birds Directive for the protection of nationally and internationally important populations of wild birds. Those sites supplied here are those with a status of 'Potential' having been identified for potential adoption under the framework.

*This data is sourced from Natural England.*



## 10.15 Nitrate Sensitive Areas

Records within 2000m

0

Areas where nitrate concentrations in drinking water sources exceeded or was at risk of exceeding the limit of 50 mg/l set by the 1980 EC Drinking Water Directive. Voluntary agricultural measures as a means of reducing the levels of nitrate were introduced by DEFRA as MAFF, with payments being made to farmers who complied. The scheme was started as a pilot in 1990 in ten areas, later implemented within 32 areas. The scheme was closed to further new entrants in 1998, although existing agreements continued for their full term. All Nitrate Sensitive Areas fell within the areas designated as Nitrate Vulnerable Zones (NVZs) in 1996 under the EC Nitrate Directive (91/676/EEC).

*This data is sourced from Natural England.*

## 10.16 Nitrate Vulnerable Zones

Records within 2000m

0

Areas at risk from agricultural nitrate pollution designated under the EC Nitrate Directive (91/676/EEC). These are areas of land that drain into waters polluted by nitrates. Farmers operating within these areas have to follow mandatory rules to tackle nitrate loss from agriculture.

*This data is sourced from Natural England and Natural Resources Wales.*

## SSSI Impact Zones and Units

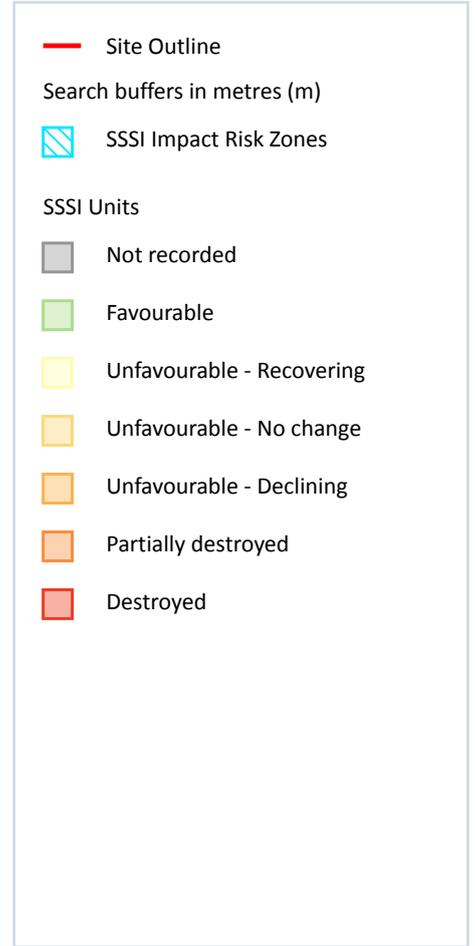
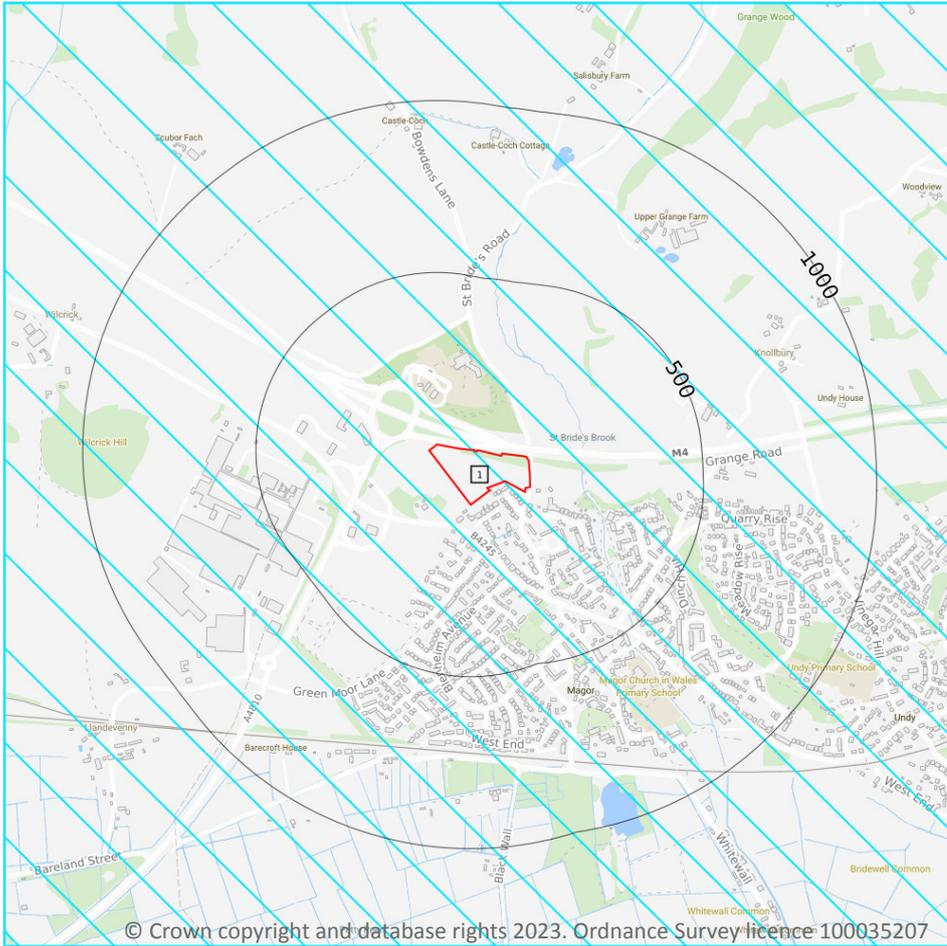

### 10.17 SSSI Impact Risk Zones

#### Records on site

1

Developed to allow rapid initial assessment of the potential risks to SSSIs posed by development proposals. They define zones around each SSSI which reflect the particular sensitivities of the features for which it is notified and indicate the types of development proposal which could potentially have adverse impacts.

Features are displayed on the SSSI Impact Zones and Units map on [page 65](#) >

ID	Location	Type of developments requiring consultation
1	On site	<b>Infrastructure - Airports, helipads and other aviation proposals.</b> <b>Air pollution - Livestock &amp; poultry units with floorspace &gt; 500m<sup>2</sup>, slurry lagoons &amp; digestate stores &gt; 4000m<sup>2</sup>.</b> <b>Combustion - General combustion processes &gt;50MW energy input. Incl: energy from waste incineration, other incineration, landfill gas generation plant, pyrolysis/gasification, anaerobic digestion, sewage treatment works, other incineration/ combustion.</b>

*This data is sourced from Natural England.*

## 10.18 SSSI Units

**Records within 2000m**

**0**

Divisions of SSSIs used to record management and condition details. Units are the smallest areas for which Natural England gives a condition assessment, however, the size of units varies greatly depending on the types of management and the conservation interest.

*This data is sourced from Natural England and Natural Resources Wales.*



## 11 Visual and cultural designations

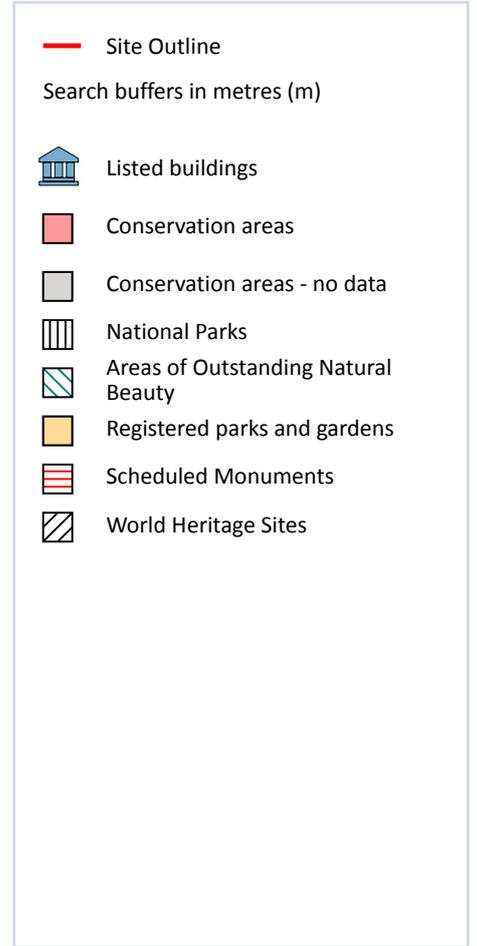

### 11.1 World Heritage Sites

Records within 250m

0

Sites designated for their globally important cultural or natural interest requiring appropriate management and protection measures. World Heritage Sites are designated to meet the UK's commitments under the World Heritage Convention.

*This data is sourced from Historic England, Cadw and Historic Environment Scotland.*

## 11.2 Area of Outstanding Natural Beauty

Records within 250m

0

Areas of Outstanding Natural Beauty (AONB) are conservation areas, chosen because they represent 18% of the finest countryside. Each AONB has been designated for special attention because of the quality of their flora, fauna, historical and cultural associations, and/or scenic views. The National Parks and Access to the Countryside Act of 1949 created AONBs and the Countryside and Rights of Way Act, 2000 added further regulation and protection. There are likely to be restrictions to some developments within these areas.

*This data is sourced from Natural England, Natural Resources Wales and Scottish Natural Heritage.*

## 11.3 National Parks

Records within 250m

0

In England and Wales, the purpose of National Parks is to conserve and enhance landscapes within the countryside whilst promoting public enjoyment of them and having regard for the social and economic well-being of those living within them. In Scotland National Parks have the additional purpose of promoting the sustainable use of the natural resources of the area and the sustainable social and economic development of its communities. The National Parks and Access to the Countryside Act 1949 established the National Park designation in England and Wales, and The National Parks (Scotland) Act 2000 in Scotland.

*This data is sourced from Natural England, Natural Resources Wales and the Scottish Government.*

## 11.4 Listed Buildings

Records within 250m

1

Buildings listed for their special architectural or historical interest. Building control in the form of 'listed building consent' is required in order to make any changes to that building which might affect its special interest. Listed buildings are graded to indicate their relative importance, however building controls apply to all buildings equally, irrespective of their grade, and apply to the interior and exterior of the building in its entirety, together with any curtilage structures.

Features are displayed on the Visual and cultural designations map on [page 67 >](#)

ID	Location	Name	Grade	Reference Number	Listed date
1	111m SW	The Vicarage, On Western Edge Of Magor Village.	II	16068	31/05/1995

*This data is sourced from Historic England, Cadw and Historic Environment Scotland.*

## 11.5 Conservation Areas

Records within 250m

0

Local planning authorities are obliged to designate as conservation areas any parts of their own area that are of special architectural or historic interest, the character and appearance of which it is desirable to preserve or enhance. Designation of a conservation area gives broader protection than the listing of individual buildings. All the features within the area, listed or otherwise, are recognised as part of its character. Conservation area designation is the means of recognising the importance of all factors and of ensuring that planning decisions address the quality of the landscape in its broadest sense.

*This data is sourced from Historic England, Cadw and Historic Environment Scotland.*

## 11.6 Scheduled Ancient Monuments

Records within 250m

0

A scheduled monument is an historic building or site that is included in the Schedule of Monuments kept by the Secretary of State for Digital, Culture, Media and Sport. The regime is set out in the Ancient Monuments and Archaeological Areas Act 1979. The Schedule of Monuments has c.20,000 entries and includes sites such as Roman remains, burial mounds, castles, bridges, earthworks, the remains of deserted villages and industrial sites. Monuments are not graded, but all are, by definition, considered to be of national importance.

*This data is sourced from Historic England, Cadw and Historic Environment Scotland.*

## 11.7 Registered Parks and Gardens

Records within 250m

0

Parks and gardens assessed to be of particular interest and of special historic interest. The emphasis being on 'designed' landscapes, rather than on planting or botanical importance. Registration is a 'material consideration' in the planning process, meaning that planning authorities must consider the impact of any proposed development on the special character of the landscape.

*This data is sourced from Historic England, Cadw and Historic Environment Scotland.*





## 12 Agricultural designations

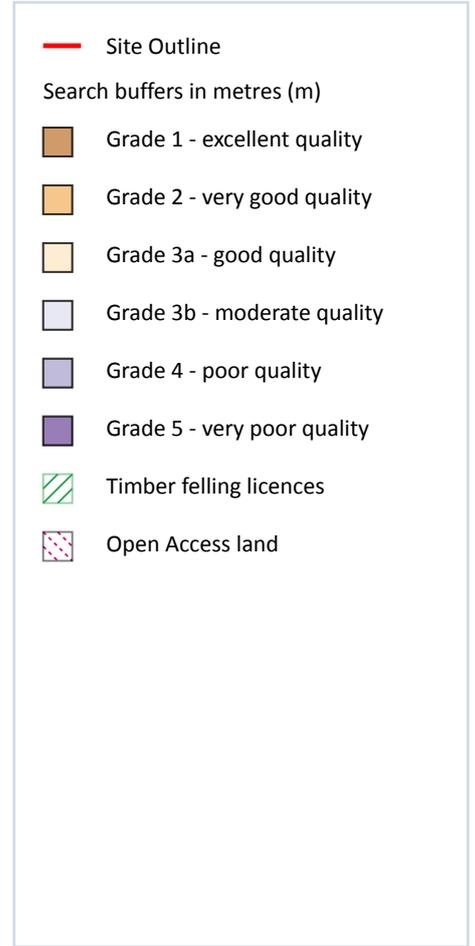
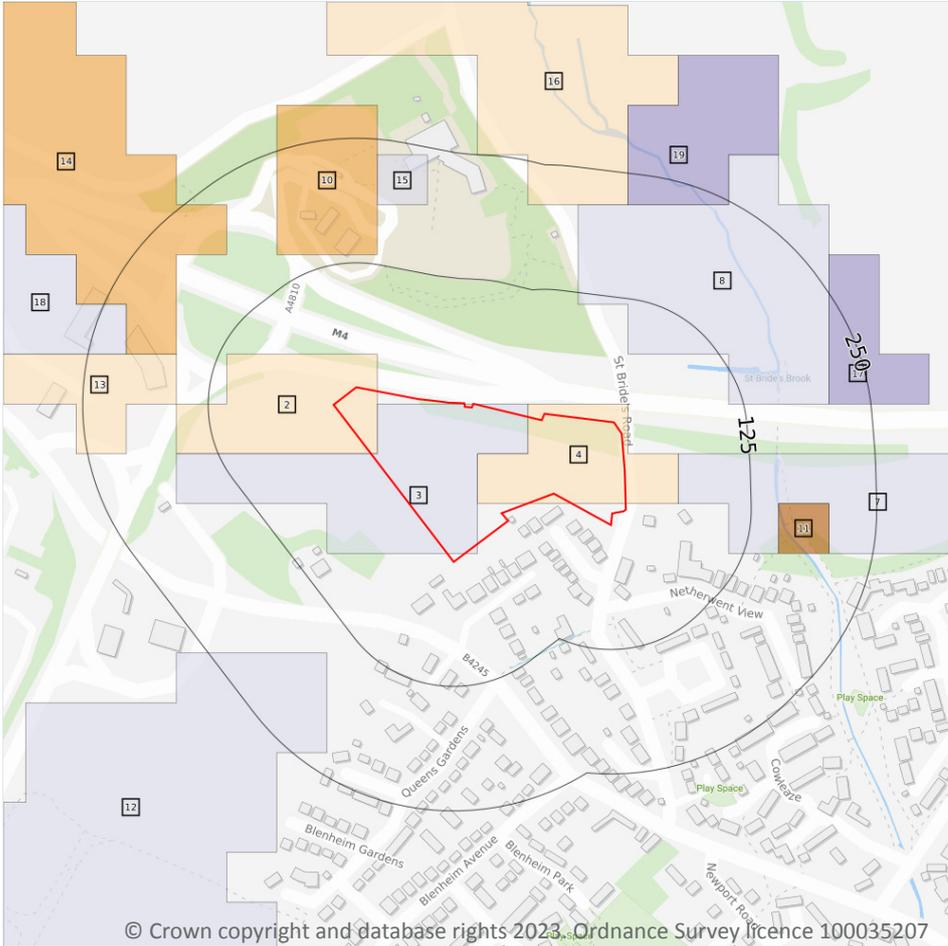

### 12.1 Agricultural Land Classification

Records within 250m

15

Classification of the quality of agricultural land taking into consideration multiple factors including climate, physical geography and soil properties. It should be noted that the categories for the grading of agricultural land are not consistent across England, Wales and Scotland.

Features are displayed on the Agricultural designations map on [page 70 >](#)

ID	Location	Classification	Description
2	On site	Grade 3a	Good to moderate quality agricultural land
3	On site	Grade 3b	Moderate quality agricultural land
4	On site	Grade 3a	Good to moderate quality agricultural land

ID	Location	Classification	Description
7	52m E	Grade 3b	Moderate quality agricultural land
8	70m NE	Grade 3b	Moderate quality agricultural land
10	133m NW	Grade 2	Good quality agricultural land
11	152m E	Grade 1	Excellent quality agricultural land
12	156m SW	Grade 3b	Moderate quality agricultural land
13	157m W	Grade 3a	Good to moderate quality agricultural land
14	165m W	Grade 2	Good quality agricultural land
15	184m NW	Grade 3b	Moderate quality agricultural land
16	207m N	Grade 3a	Good to moderate quality agricultural land
17	209m E	Grade 4	Poor quality agricultural land
18	213m W	Grade 3b	Moderate quality agricultural land
19	219m NE	Grade 4	Poor quality agricultural land

*This data is sourced from Natural Resources Wales.*

## 12.2 Open Access Land

**Records within 250m**

**0**

The Countryside and Rights of Way Act 2000 (CROW Act) gives a public right of access to land without having to use paths. Access land includes mountains, moors, heaths and downs that are privately owned. It also includes common land registered with the local council and some land around the England Coast Path. Generally permitted activities on access land are walking, running, watching wildlife and climbing.

*This data is sourced from Natural England and Natural Resources Wales.*

## 12.3 Tree Felling Licences

**Records within 250m**

**0**

Felling Licence Application (FLA) areas approved by Forestry Commission England. Anyone wishing to fell trees must ensure that a licence or permission under a grant scheme has been issued by the Forestry Commission before any felling is carried out or that one of the exceptions apply.

*This data is sourced from the Forestry Commission.*



## 12.4 Environmental Stewardship Schemes

Records within 250m

0

Environmental Stewardship covers a range of schemes that provide financial incentives to farmers, foresters and land managers to look after and improve the environment. The schemes identified may be historical schemes that have now expired, or may still be active.

*This data is sourced from Natural England.*

## 12.5 Countryside Stewardship Schemes

Records within 250m

0

Countryside Stewardship covers a range of schemes that provide financial incentives to farmers, foresters and land managers to look after and improve the environment. Main objectives are to improve the farmed environment for wildlife and to reduce diffuse water pollution.

*This data is sourced from Natural England.*

## 13 Habitat designations

### 13.1 Priority Habitat Inventory

Records within 250m	0
---------------------	---

Habitats of principal importance as named under Natural Environment and Rural Communities Act (2006) Section 41.

*This data is sourced from Natural England.*

### 13.2 Habitat Networks

Records within 250m	0
---------------------	---

Habitat networks for 18 priority habitat networks (based primarily, but not exclusively, on the priority habitat inventory) and areas suitable for the expansion of networks through restoration and habitat creation.

*This data is sourced from Natural England.*

### 13.3 Open Mosaic Habitat

Records within 250m	0
---------------------	---

Sites verified as Open Mosaic Habitat. Mosaic habitats are brownfield sites that are identified under the UK Biodiversity Action Plan as a priority habitat due to the habitat variation within a single site, supporting an array of invertebrates.

*This data is sourced from Natural England.*

### 13.4 Limestone Pavement Orders

Records within 250m	0
---------------------	---

Limestone pavements are outcrops of limestone where the surface has been worn away by natural means over millennia. These rocks have the appearance of paving blocks, hence their name. Not only do they have geological interest, they also provide valuable habitats for wildlife. These habitats are threatened due to their removal for use in gardens and water features. Many limestone pavements have been designated as SSSIs which affords them some protection. In addition, Section 34 of the Wildlife and Countryside Act 1981 gave them additional protection via the creation of Limestone Pavement Orders, which made it a criminal offence to remove any part of the outcrop. The associated Limestone Pavement Priority Habitat is part of the UK Biodiversity Action Plan priority habitat in England.

*This data is sourced from Natural England.*

## 14 Geology 1:10,000 scale - Availability



— Site Outline  
Search buffers in metres (m)

- Full coverage
- Partial coverage
- No coverage

### 14.1 10k Availability

Records within 500m

1

An indication on the coverage of 1:10,000 scale geology data for the site, the most detailed dataset provided by the British Geological Survey. Either 'Full', 'Partial' or 'No coverage' for each geological theme.

Features are displayed on the Geology 1:10,000 scale - Availability map on [page 74](#) >

ID	Location	Artificial	Superficial	Bedrock	Mass movement	Sheet No.
1	On site	No coverage	Full	Full	No coverage	ST48NW

This data is sourced from the British Geological Survey.



## Geology 1:10,000 scale - Artificial and made ground

### 14.2 Artificial and made ground (10k)

Records within 500m

0

Details of made, worked, infilled, disturbed and landscaped ground at 1:10,000 scale. Artificial ground can be associated with potentially contaminated material, unpredictable engineering conditions and instability.

*This data is sourced from the British Geological Survey.*



## Geology 1:10,000 scale - Superficial

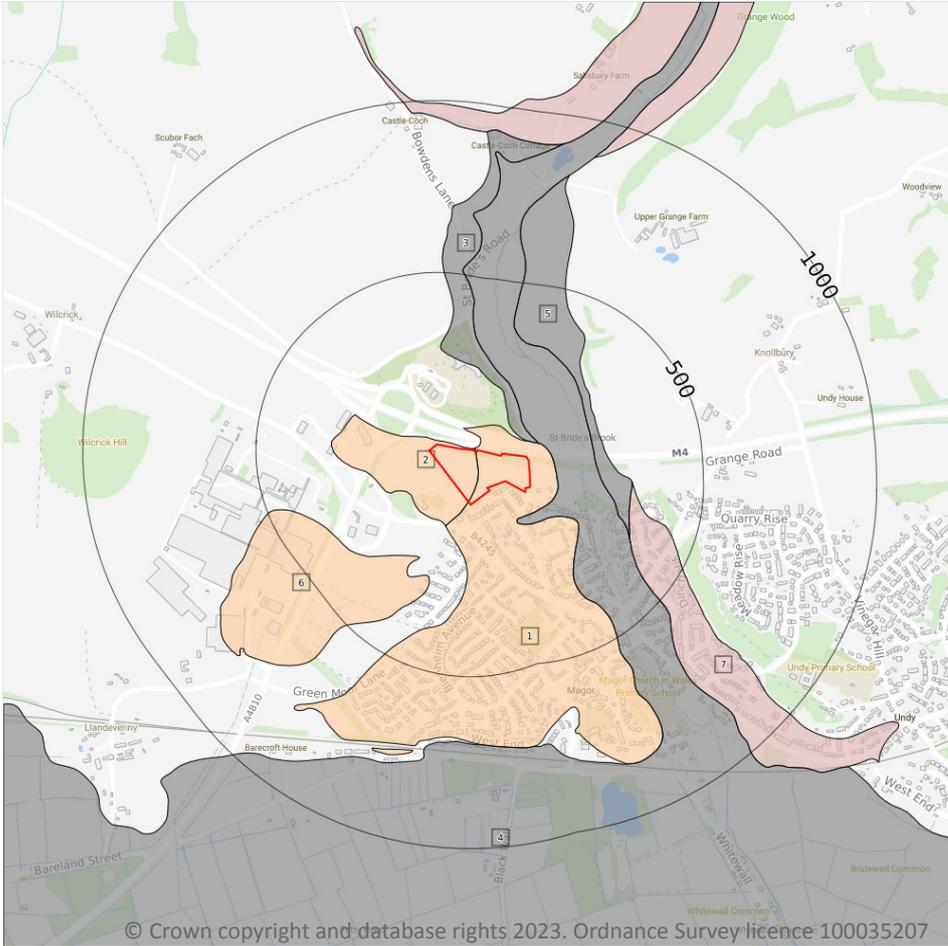

- Site Outline
- Search buffers in metres (m)
- Landslip (10k)
- Superficial geology (10k)  
Please see table for more details.

### 14.3 Superficial geology (10k)

Records within 500m

7

Superficial geological deposits at 1:10,000 scale. Also known as 'drift', these are the youngest geological deposits, formed during the Quaternary. They rest on older deposits or rocks referred to as bedrock.

Features are displayed on the Geology 1:10,000 scale - Superficial map on [page 76](#) >

ID	Location	LEX Code	Description	Rock description
1	On site	RTD2-XSV	River Terrace Deposits, 2 - Sand And Gravel	Sand And Gravel
2	On site	T2T3-XSV	River Terrace Deposits, 2 To 3 - Sand And Gravel	Sand And Gravel
3	45m NE	TFD1-CZ	Tidal Flat Deposits, 1 - Silty Clay	Clay, Silty
4	53m NE	TFD1-CZ	Tidal Flat Deposits, 1 - Silty Clay	Clay, Silty



ID	Location	LEX Code	Description	Rock description
5	189m E	TFD1-CZ	Tidal Flat Deposits, 1 - Silty Clay	Clay, Silty
6	213m SW	T2T3-XSV	River Terrace Deposits, 2 To 3 - Sand And Gravel	Sand And Gravel
7	291m E	HEAD- XCZSV	Head - Clay, Silt, Sand And Gravel	Clay, Silt, Sand And Gravel

*This data is sourced from the British Geological Survey.*

## 14.4 Landslip (10k)

**Records within 500m**

**0**

Mass movement deposits on BGS geological maps at 1:10,000 scale. Primarily superficial deposits that have moved down slope under gravity to form landslips. These affect bedrock, other superficial deposits and artificial ground.

*This data is sourced from the British Geological Survey.*



## Geology 1:10,000 scale - Bedrock

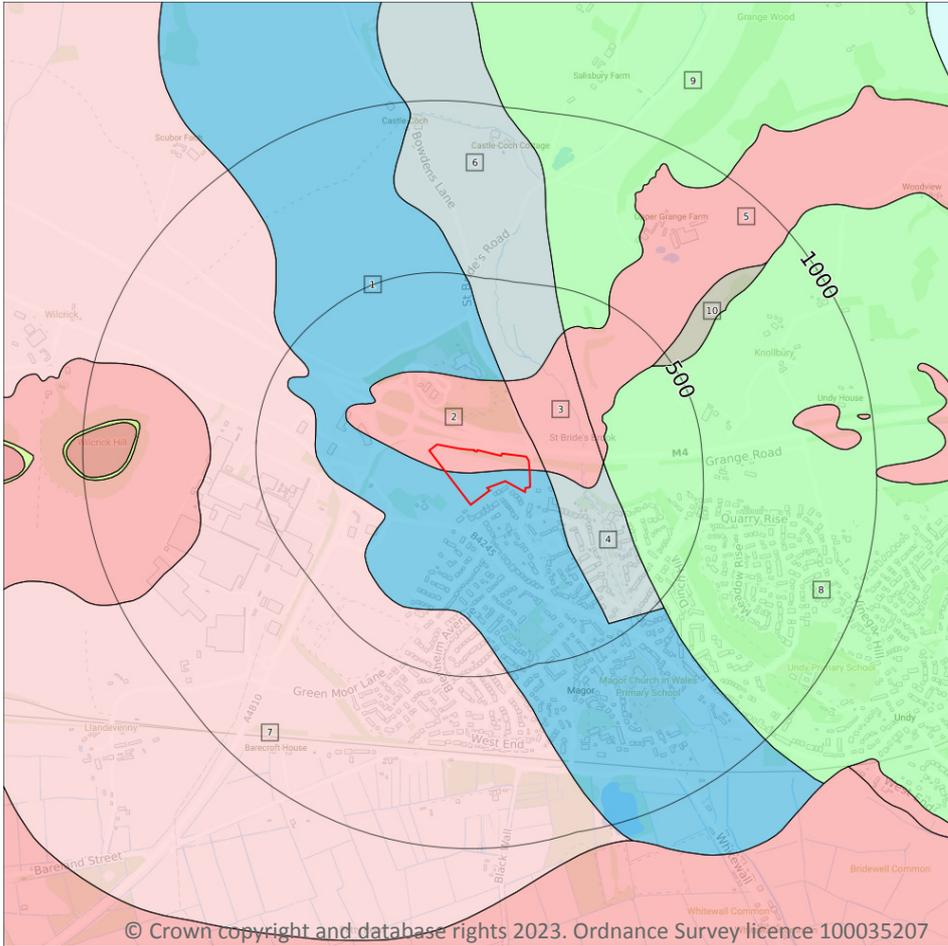

- Site Outline
- Search buffers in metres (m)
- Bedrock faults and other linear features (10k)
- Bedrock geology (10k)  
Please see table for more details.

### 14.5 Bedrock geology (10k)

Records within 500m

10

Bedrock geology at 1:10,000 scale. The main mass of rocks forming the Earth and present everywhere, whether exposed at the surface in outcrops or concealed beneath superficial deposits or water.

Features are displayed on the Geology 1:10,000 scale - Bedrock map on [page 78 >](#)

ID	Location	LEX Code	Description	Rock age
1	On site	AVO-LMST	Avon Group - Limestone	Courseyan Age
2	On site	MMMMF-CONG	Mercia Mudstone Group (marginal Facies) - Conglomerate	Triassic Period
3	33m E	MMMMF-CONG	Mercia Mudstone Group (marginal Facies) - Conglomerate	Triassic Period

ID	Location	LEX Code	Description	Rock age
4	47m E	AVO-MDLM	Avon Group - Mudstone And Limestone, Interbedded	Courseyan Age
5	203m E	MMMF- CONG	Mercia Mudstone Group (marginal Facies) - Conglomerate	Triassic Period
6	212m N	AVO-MDLM	Avon Group - Mudstone And Limestone, Interbedded	Courseyan Age
7	214m SW	TSG-SDST	Tintern Sandstone Formation - Sandstone	Tournaisian Age - Famennian Age
8	215m E	BRL-DOLO	Black Rock Limestone Subgroup - Dolostone	Chadian Age - Courseyan Age
9	379m NE	BRL-DOLO	Black Rock Limestone Subgroup - Dolostone	Chadian Age - Courseyan Age
10	448m NE	MMG-SDST	Mercia Mudstone Group - Sandstone	Rhaetian Age - Early Triassic Epoch

*This data is sourced from the British Geological Survey.*

## 14.6 Bedrock faults and other linear features (10k)

**Records within 500m**

**0**

Linear features at the ground or bedrock surface at 1:10,000 scale of six main types; rock, fault, fold axis, mineral vein, alteration area or landform. Features are either observed or inferred, and relate primarily to bedrock.

*This data is sourced from the British Geological Survey.*

## 15 Geology 1:50,000 scale - Availability

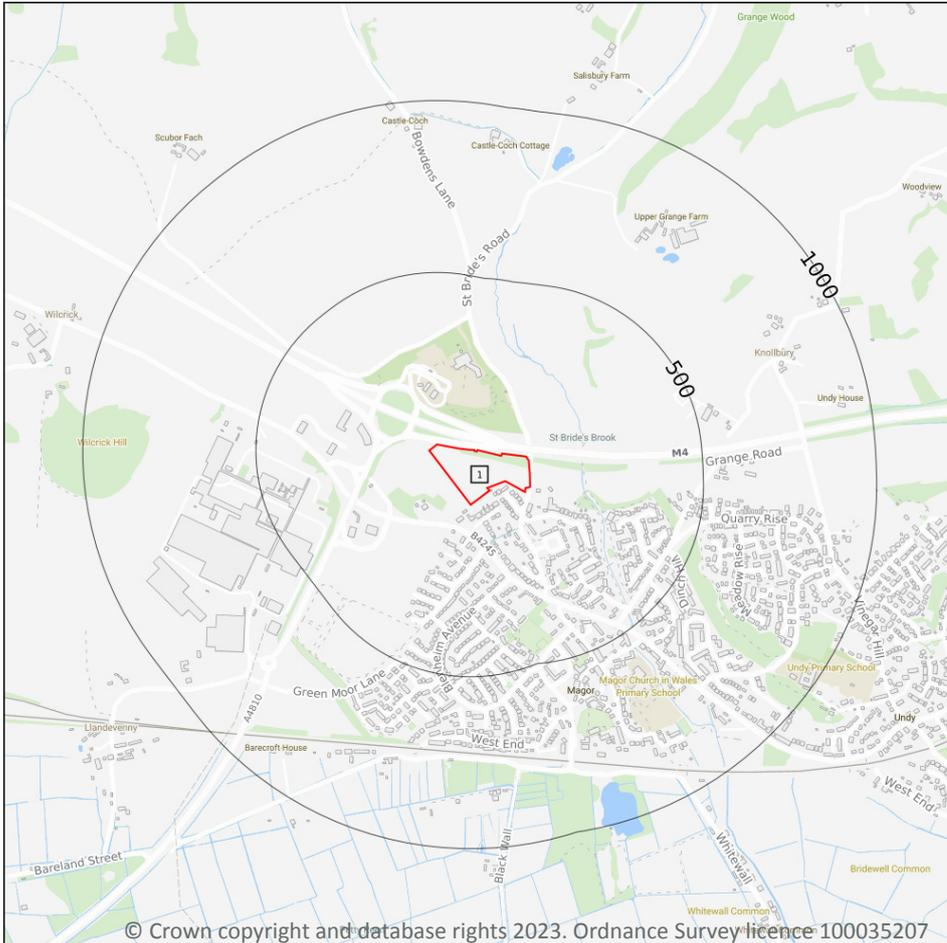

- Site Outline
- Search buffers in metres (m)
- Geological map tile

### 15.1 50k Availability

Records within 500m

1

An indication on the coverage of 1:50,000 scale geology data for the site. Either 'Full' or 'No coverage' for each geological theme. Where 50k data is not available, this area has been filled in with 625k scale data.

Features are displayed on the Geology 1:50,000 scale - Availability map on [page 80](#) >

ID	Location	Artificial	Superficial	Bedrock	Mass movement	Sheet No.
1	On site	No coverage	Full	Full	Full	EW250_chepstow_v4

This data is sourced from the British Geological Survey.



## Geology 1:50,000 scale - Artificial and made ground

### 15.2 Artificial and made ground (50k)

Records within 500m

0

Details of made, worked, infilled, disturbed and landscaped ground at 1:50,000 scale. Artificial ground can be associated with potentially contaminated material, unpredictable engineering conditions and instability.

*This data is sourced from the British Geological Survey.*

### 15.3 Artificial ground permeability (50k)

Records within 50m

0

A qualitative classification of estimated rates of vertical movement of water from the ground surface through the unsaturated zone of any artificial deposits (the zone between the land surface and the water table).

*This data is sourced from the British Geological Survey.*

## Geology 1:50,000 scale - Superficial

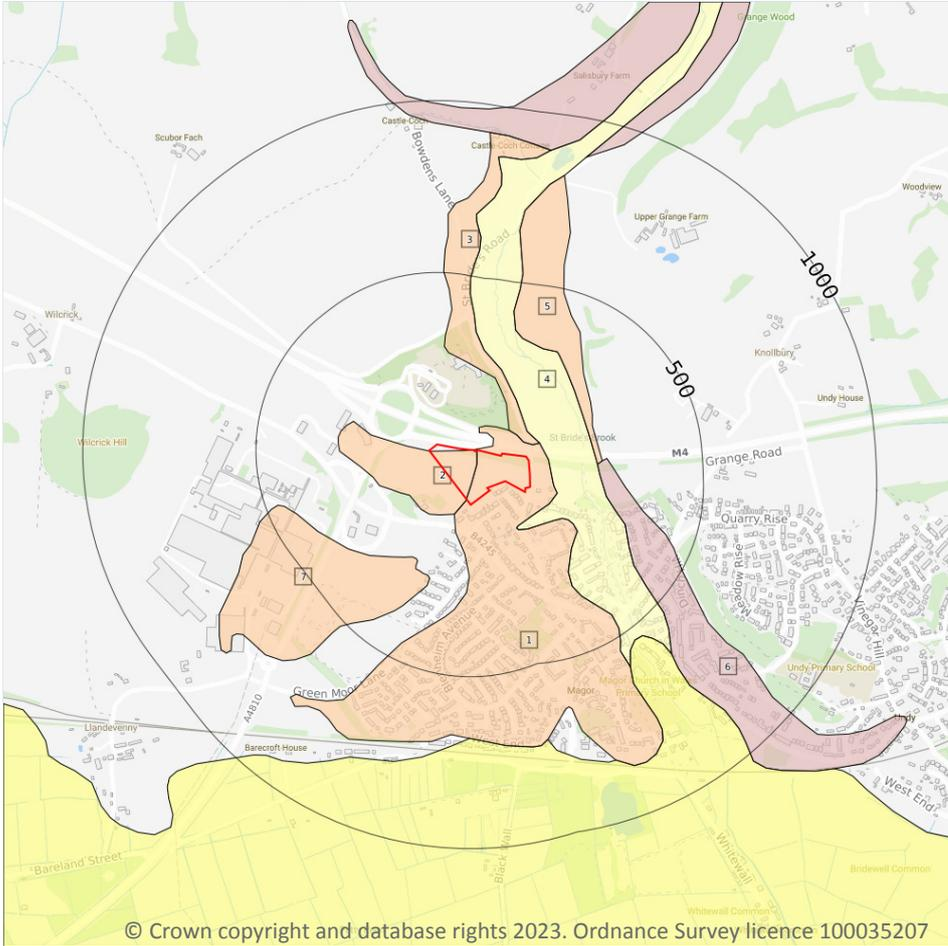

- Site Outline
- Search buffers in metres (m)
- Landslip (50k)
- Superficial geology (50k)  
Please see table for more details.

### 15.4 Superficial geology (50k)

Records within 500m

7

Superficial geological deposits at 1:50,000 scale. Also known as 'drift', these are the youngest geological deposits, formed during the Quaternary. They rest on older deposits or rocks referred to as bedrock.

Features are displayed on the Geology 1:50,000 scale - Superficial map on [page 82](#) >

ID	Location	LEX Code	Description	Rock description
1	On site	RTD2-XSV	RIVER TERRACE DEPOSITS, 2	SAND AND GRAVEL
2	On site	T2T3-XSV	RIVER TERRACE DEPOSITS, 2 TO 3	SAND AND GRAVEL
3	39m NE	RTD1-XSV	RIVER TERRACE DEPOSITS, 1	SAND AND GRAVEL
4	52m E	ALV-XCZSV	ALLUVIUM	CLAY, SILT, SAND AND GRAVEL



ID	Location	LEX Code	Description	Rock description
5	188m E	RTD1-XSV	RIVER TERRACE DEPOSITS, 1	SAND AND GRAVEL
6	197m E	HEAD-XCZSV	HEAD	CLAY, SILT, SAND AND GRAVEL
7	222m SW	RTD3-XSV	RIVER TERRACE DEPOSITS, 3	SAND AND GRAVEL

This data is sourced from the British Geological Survey.

## 15.5 Superficial permeability (50k)

**Records within 50m** **3**

A qualitative classification of estimated rates of vertical movement of water from the ground surface through the unsaturated zone of any superficial deposits (the zone between the land surface and the water table).

Location	Flow type	Maximum permeability	Minimum permeability
On site	Intergranular	Very High	High
On site	Intergranular	Very High	High
38m NE	Intergranular	Very High	High

This data is sourced from the British Geological Survey.

## 15.6 Landslip (50k)

**Records within 500m** **0**

Mass movement deposits on BGS geological maps at 1:50,000 scale. Primarily superficial deposits that have moved down slope under gravity to form landslips. These affect bedrock, other superficial deposits and artificial ground.

This data is sourced from the British Geological Survey.

## 15.7 Landslip permeability (50k)

**Records within 50m** **0**

A qualitative classification of estimated rates of vertical movement of water from the ground surface through the unsaturated zone of any landslip deposits (the zone between the land surface and the water table).

This data is sourced from the British Geological Survey.



## Geology 1:50,000 scale - Bedrock

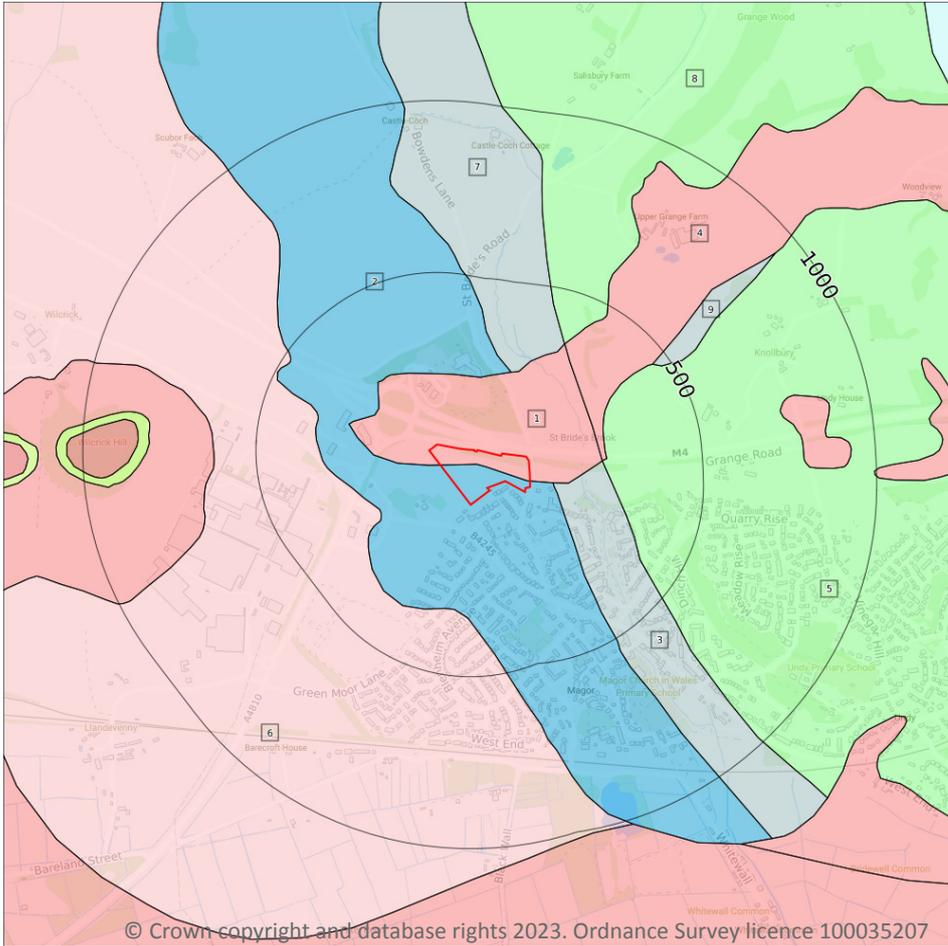

— Site Outline

Search buffers in metres (m)

.... Bedrock faults and other linear features (50k)

Bedrock geology (50k)  
Please see table for more details.

### 15.8 Bedrock geology (50k)

Records within 500m

9

Bedrock geology at 1:50,000 scale. The main mass of rocks forming the Earth and present everywhere, whether exposed at the surface in outcrops or concealed beneath superficial deposits or water.

Features are displayed on the Geology 1:50,000 scale - Bedrock map on [page 84](#) >

ID	Location	LEX Code	Description	Rock age
1	On site	MMMF- CONG	MERCIA MUDSTONE GROUP (MARGINAL FACIES) - CONGLOMERATE	-
2	On site	AVO-LMST	AVON GROUP - LIMESTONE	TOURNAISIAN
3	67m E	AVO-MDLM	AVON GROUP - MUDSTONE AND LIMESTONE, INTERBEDDED	TOURNAISIAN

ID	Location	LEX Code	Description	Rock age
4	204m E	MMMF- CONG	MERCIA MUDSTONE GROUP (MARGINAL FACIES) - CONGLOMERATE	-
5	212m E	BRL-DOLO	BLACK ROCK LIMESTONE SUBGROUP - DOLOSTONE	TOURNAISIAN
6	218m W	TSG-SDST	TINTERN SANDSTONE FORMATION - SANDSTONE	FAMENNIAN
7	238m N	AVO-MDLM	AVON GROUP - MUDSTONE AND LIMESTONE, INTERBEDDED	TOURNAISIAN
8	346m NE	BRL-DOLO	BLACK ROCK LIMESTONE SUBGROUP - DOLOSTONE	TOURNAISIAN
9	453m NE	AVO-MDLM	AVON GROUP - MUDSTONE AND LIMESTONE, INTERBEDDED	TOURNAISIAN

*This data is sourced from the British Geological Survey.*

## 15.9 Bedrock permeability (50k)

**Records within 50m**

**2**

A qualitative classification of estimated rates of vertical movement of water from the ground surface through the unsaturated zone of bedrock (the zone between the land surface and the water table).

Location	Flow type	Maximum permeability	Minimum permeability
On site	Fracture	Very High	Very High
On site	Fracture	Very High	Very High

*This data is sourced from the British Geological Survey.*

## 15.10 Bedrock faults and other linear features (50k)

**Records within 500m**

**0**

Linear features at the ground or bedrock surface at 1:50,000 scale of six main types; rock, fault, fold axis, mineral vein, alteration area or landform. Features are either observed or inferred, and relate primarily to bedrock.

*This data is sourced from the British Geological Survey.*



## 16 Boreholes

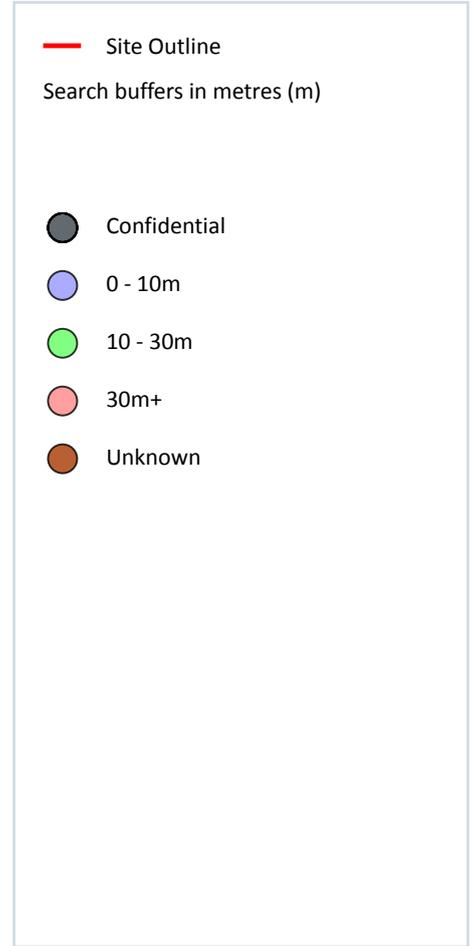

© Crown copyright and database rights 2023. Ordnance Survey licence 100035207

### 16.1 BGS Boreholes

Records within 250m

25

The Single Onshore Boreholes Index (SOBI); an index of over one million records of boreholes, shafts and wells from all forms of drilling and site investigation work held by the British Geological Survey. Covering onshore and nearshore boreholes dating back to at least 1790 and ranging from one to several thousand metres deep.

Features are displayed on the Boreholes map on [page 86](#) >

ID	Location	Grid reference	Name	Length	Confidential	Web link
1	On site	342326 187782	LONDON-SOUTH WALES MOTORWAY 65	7.62	N	<a href="#">16023277</a> ↗
2	10m E	342353 187773	2ND SEVERN CROSSING 7108	10.0	N	<a href="#">387049</a> ↗

ID	Location	Grid reference	Name	Length	Confidential	Web link
3	21m NW	342094 187835	LONDON-SOUTH WALES MOTORWAY 64	3.04	N	<a href="#">16023276</a> ↗
4	48m NE	342341 187829	2ND SEVERN CROSSING 7109	9.8	N	<a href="#">387050</a> ↗
A	86m E	342430 187770	LONDON-SOUTH WALES MOTORWAY 108	4.26	N	<a href="#">16023295</a> ↗
A	94m E	342438 187771	LONDON-SOUTH WALES MOTORWAY 109	3.35	N	<a href="#">16023296</a> ↗
A	99m E	342443 187770	LONDON-SOUTH WALES MOTORWAY 66A	7.62	N	<a href="#">16023280</a> ↗
5	105m NW	341996 187885	LONDON-SOUTH WALES MOTORWAY 61	6.09	N	<a href="#">16023274</a> ↗
A	106m E	342452 187740	M4 SECOND SEVERN CROSSING, MAIN ONSHORE GI TP 7411	4.7	N	<a href="#">387074</a> ↗
A	106m E	342450 187769	LONDON-SOUTH WALES MOTORWAY 110	3.2	N	<a href="#">16023297</a> ↗
A	109m E	342454 187753	M4 SECOND SEVERN CROSSING, MAIN ONSHORE GI TP7412	1.7	N	<a href="#">387073</a> ↗
6	110m NW	341962 187855	LONDON-SOUTH WALES MOTORWAY 62	4.64	N	<a href="#">16023275</a> ↗
7	114m E	342444 187823	LONDON-SOUTH WALES MOTORWAY 66	9.14	N	<a href="#">16023278</a> ↗
A	116m E	342460 187774	LONDON-SOUTH WALES MOTORWAY 111	4.26	N	<a href="#">16023298</a> ↗
A	121m E	342465 187767	LONDON-SOUTH WALES MOTORWAY 113	3.2	N	<a href="#">16023301</a> ↗
A	127m E	342471 187767	LONDON-SOUTH WALES MOTORWAY 112	3.35	N	<a href="#">16023299</a> ↗
8	157m E	342504 187738	2ND SEVERN CROSSING 7105	11.43	N	<a href="#">387047</a> ↗
9	173m E	342507 187827	2ND SEVERN CROSSING 7106	15.0	N	<a href="#">387048</a> ↗
10	202m W	341887 187689	M4CAN: Key Stage 6 BHM4CAN150	10.3	N	<a href="#">20783603</a> ↗
11	211m NW	341889 187927	LONDON-SOUTH WALES MOTORWAY 59	6.09	N	<a href="#">16023266</a> ↗
12	215m NW	341867 187900	LONDON-SOUTH WALES MOTORWAY 60	1.42	N	<a href="#">16023269</a> ↗



ID	Location	Grid reference	Name	Length	Confidential	Web link
13	218m E	342564 187743	M4 SECOND SEVERN CROSSING, MAIN ONSHORE GI TP 7408	1.9	N	<a href="#">387077 ↗</a>
B	229m E	342570 187807	M4 SECOND SEVERN CROSSING, MAIN ONSHORE GI TP 7410	1.7	N	<a href="#">387075 ↗</a>
B	229m E	342568 187818	M4 SECOND SEVERN CROSSING, MAIN ONSHORE GI TP 7409	3.5	N	<a href="#">387076 ↗</a>
14	241m E	342588 187731	M4 SECOND SEVERN CROSSING, MAIN ONSHORE GI TP 7407	4.3	N	<a href="#">387078 ↗</a>

*This data is sourced from the British Geological Survey.*

## 17 Natural ground subsidence - Shrink swell clays

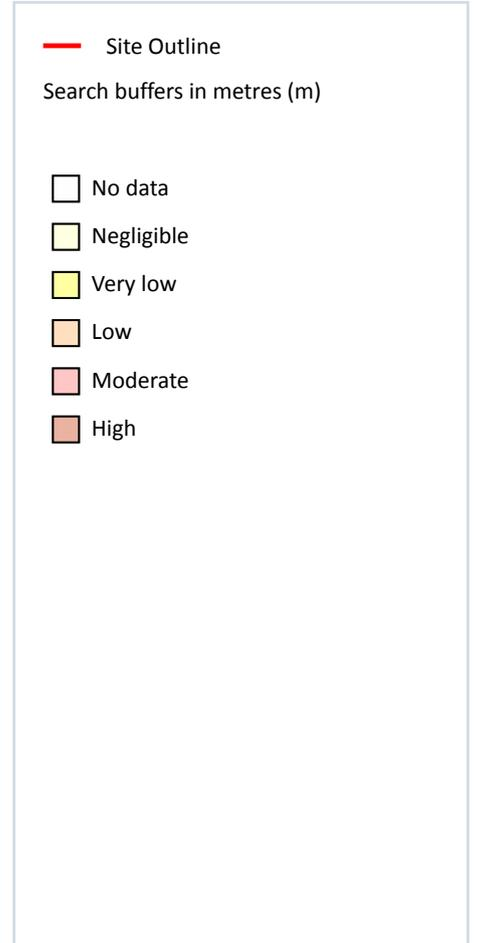
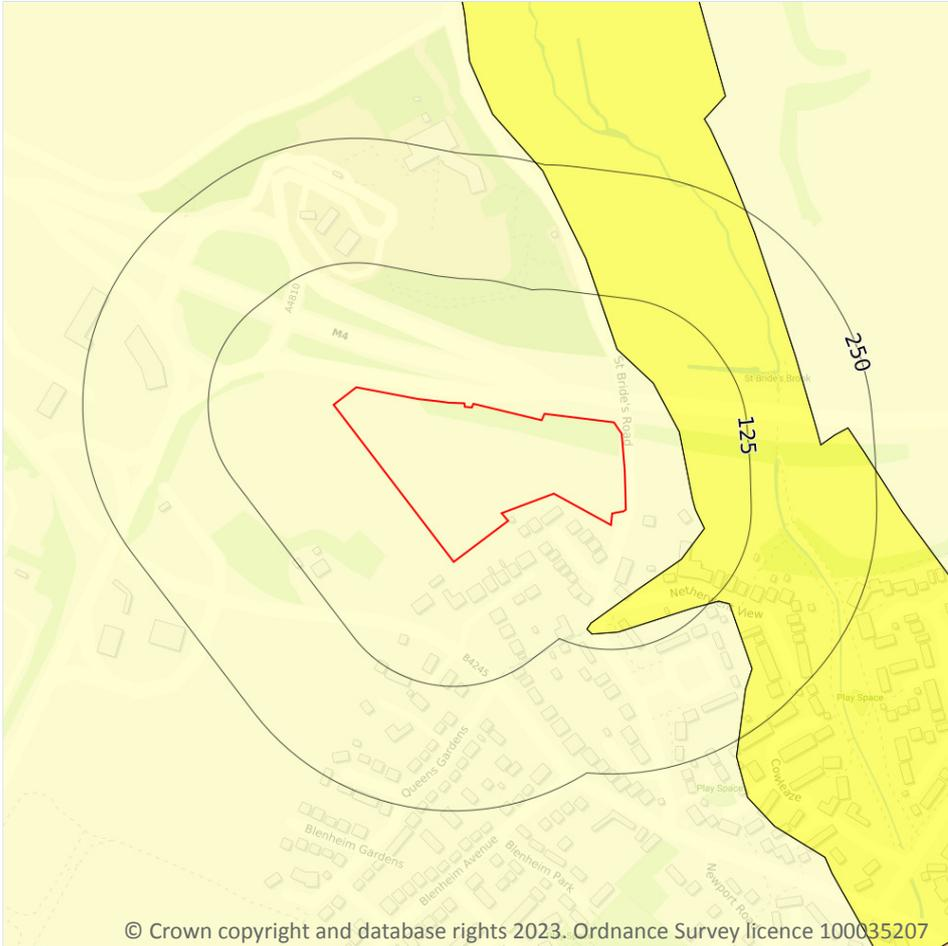

### 17.1 Shrink swell clays

#### Records within 50m

1

The potential hazard presented by soils that absorb water when wet (making them swell), and lose water as they dry (making them shrink). This shrink-swell behaviour is controlled by the type and amount of clay in the soil, and by seasonal changes in the soil moisture content (related to rainfall and local drainage).

Features are displayed on the Natural ground subsidence - Shrink swell clays map on [page 89](#) >

Location	Hazard rating	Details
On site	Negligible	Ground conditions predominantly non-plastic.

*This data is sourced from the British Geological Survey.*

## Natural ground subsidence - Running sands

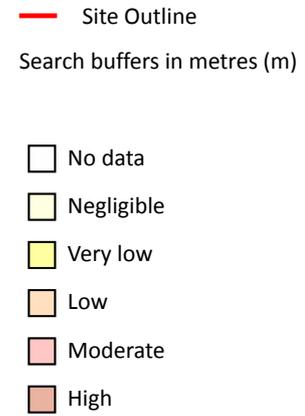
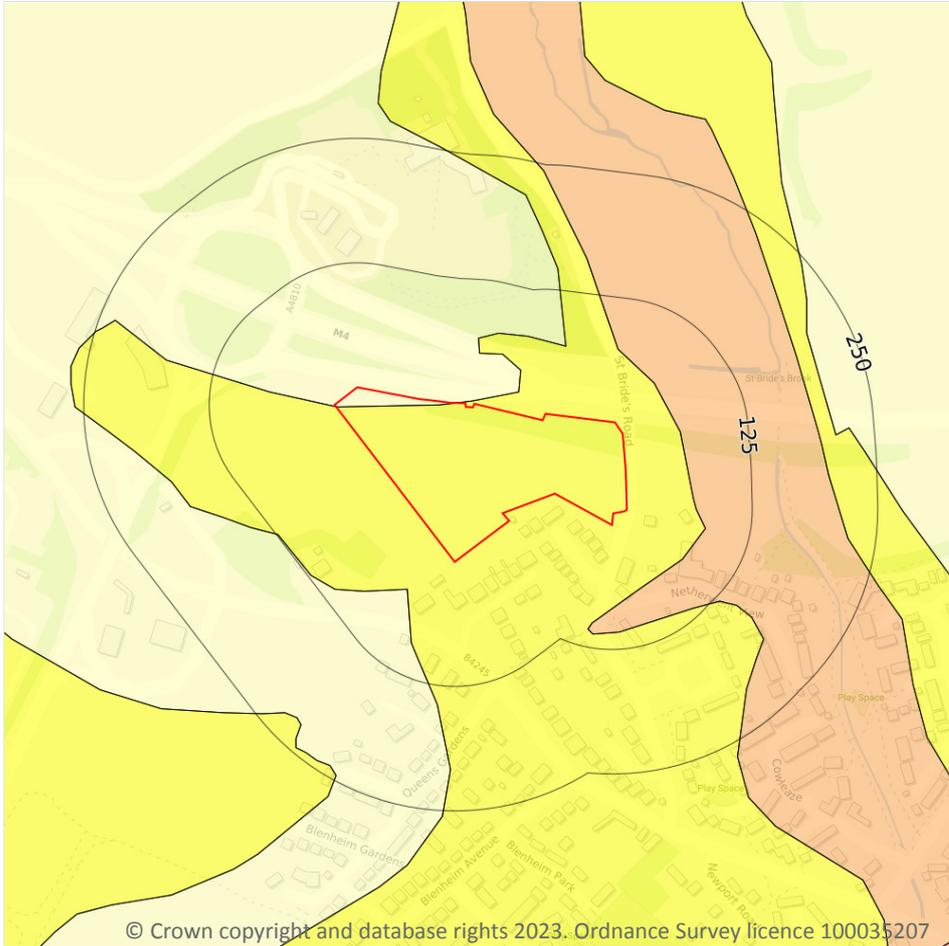

### 17.2 Running sands

Records within 50m

2

The potential hazard presented by rocks that can contain loosely-packed sandy layers that can become fluidised by water flowing through them. Such sands can 'run', removing support from overlying buildings and causing potential damage.

Features are displayed on the Natural ground subsidence - Running sands map on [page 90](#) >

Location	Hazard rating	Details
On site	Negligible	Running sand conditions are not thought to occur whatever the position of the water table. No identified constraints on lands use due to running conditions.

Location	Hazard rating	Details
On site	Very low	Running sand conditions are unlikely. No identified constraints on land use due to running conditions unless water table rises rapidly.

*This data is sourced from the British Geological Survey.*

## Natural ground subsidence - Compressible deposits

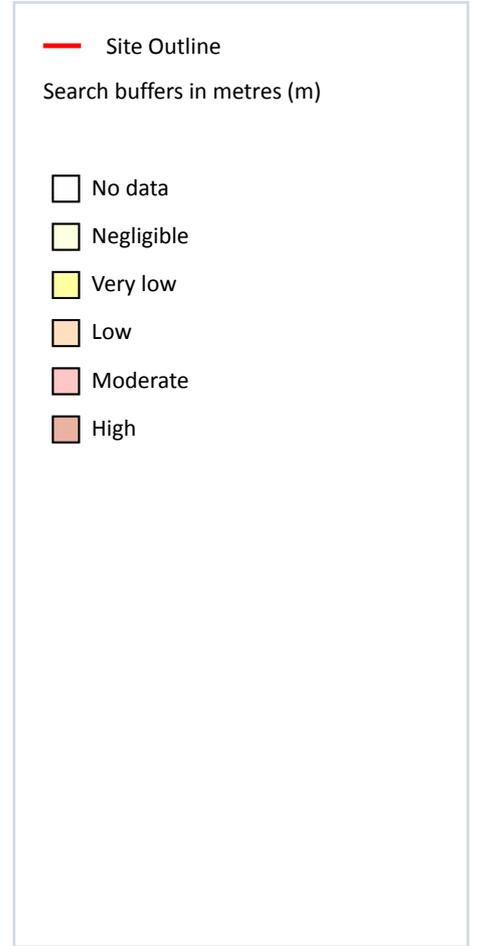
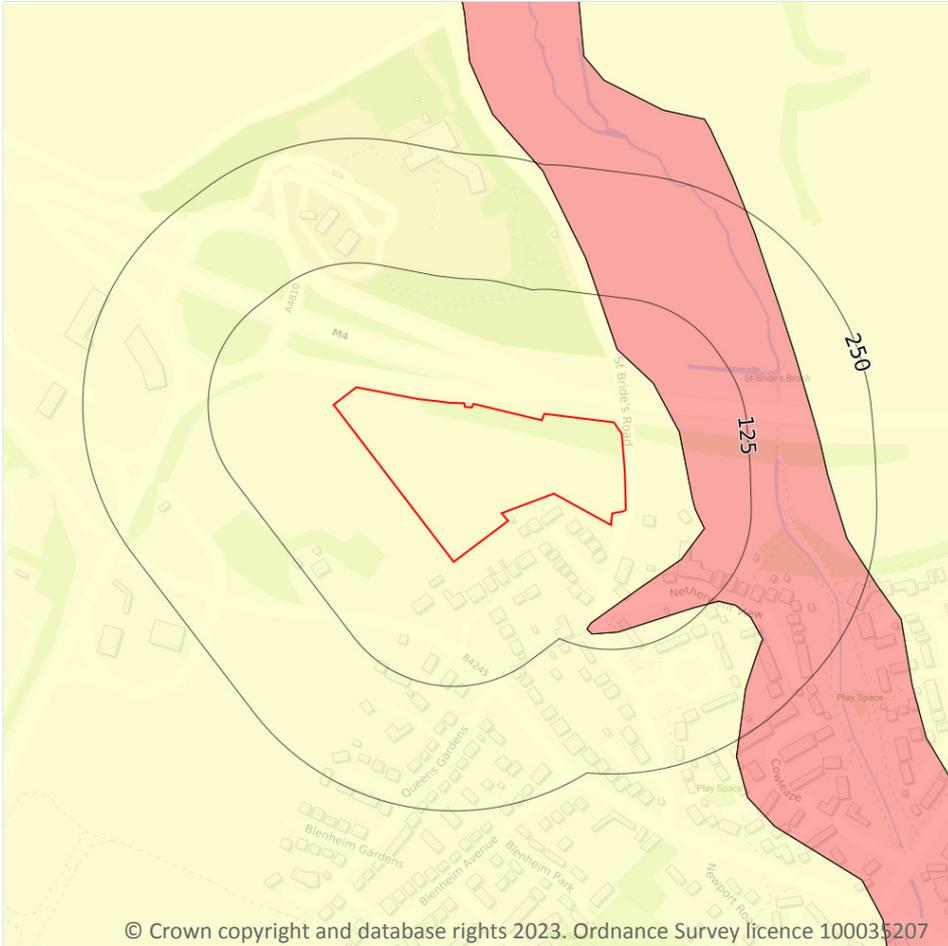

### 17.3 Compressible deposits

Records within 50m

1

The potential hazard presented by types of ground that may contain layers of very soft materials like clay or peat and may compress if loaded by overlying structures, or if the groundwater level changes, potentially resulting in depression of the ground and disturbance of foundations.

Features are displayed on the Natural ground subsidence - Compressible deposits map on [page 92 >](#)

Location	Hazard rating	Details
On site	Negligible	Compressible strata are not thought to occur.

This data is sourced from the British Geological Survey.

## Natural ground subsidence - Collapsible deposits

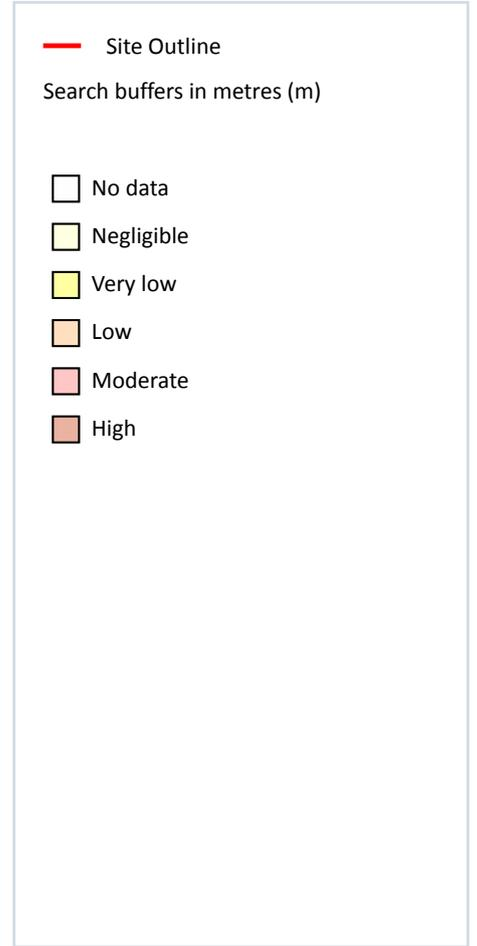
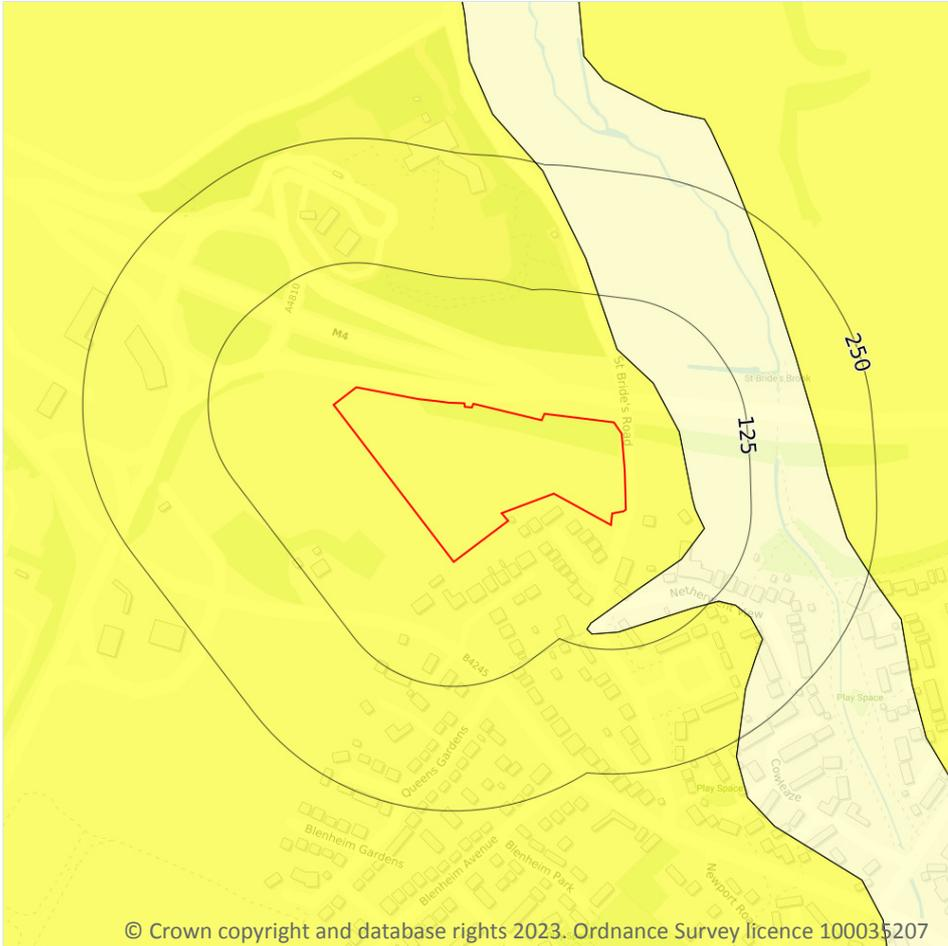

### 17.4 Collapsible deposits

Records within 50m

1

The potential hazard presented by natural deposits that could collapse when a load (such as a building) is placed on them or they become saturated with water.

Features are displayed on the Natural ground subsidence - Collapsible deposits map on [page 93 >](#)

Location	Hazard rating	Details
On site	Very low	Deposits with potential to collapse when loaded and saturated are unlikely to be present.

*This data is sourced from the British Geological Survey.*



## Natural ground subsidence - Landslides

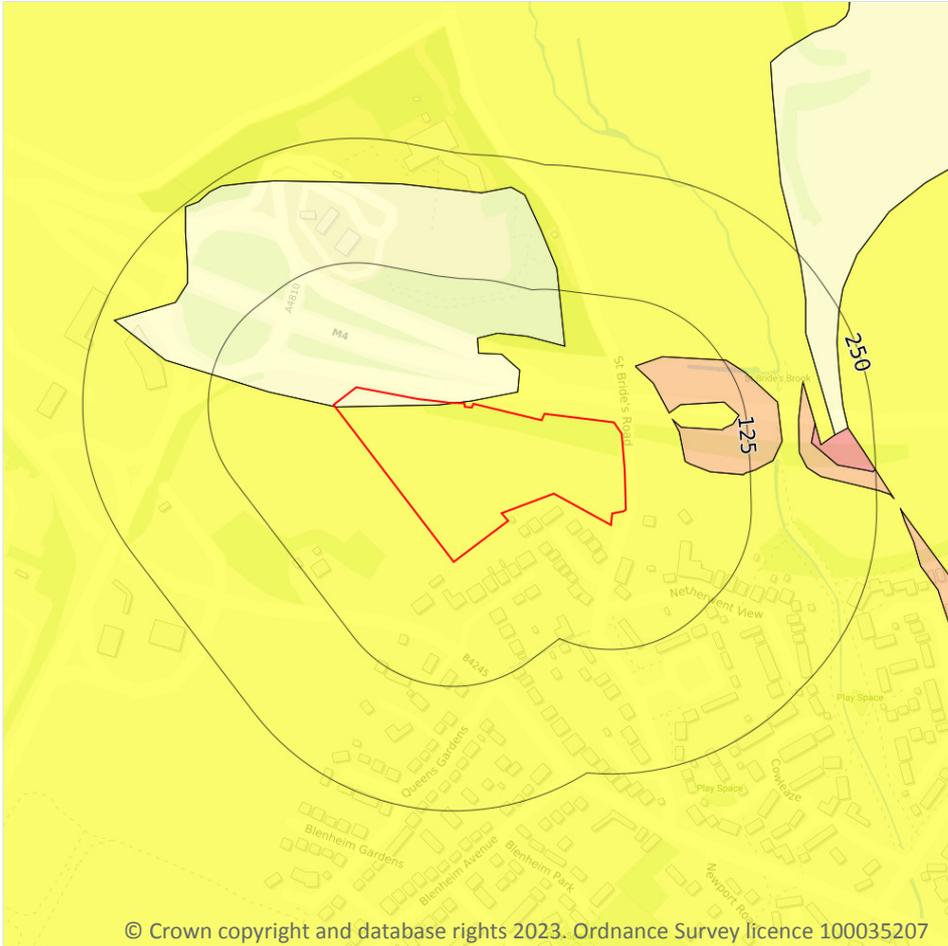

— Site Outline  
Search buffers in metres (m)

- No data
- Negligible
- Very low
- Low
- Moderate
- High

### 17.5 Landslides

Records within 50m

2

The potential for landsliding (slope instability) to be a hazard assessed using 1:50,000 scale digital maps of superficial and bedrock deposits, combined with information from the BGS National Landslide Database and scientific and engineering reports.

Features are displayed on the Natural ground subsidence - Landslides map on [page 94 >](#)

Location	Hazard rating	Details
On site	Negligible	Slope instability problems are not thought to occur but consideration to potential problems of adjacent areas impacting on the site should always be considered.

Location	Hazard rating	Details
On site	Very low	Slope instability problems are not likely to occur but consideration to potential problems of adjacent areas impacting on the site should always be considered.

*This data is sourced from the British Geological Survey.*

## Natural ground subsidence - Ground dissolution of soluble rocks

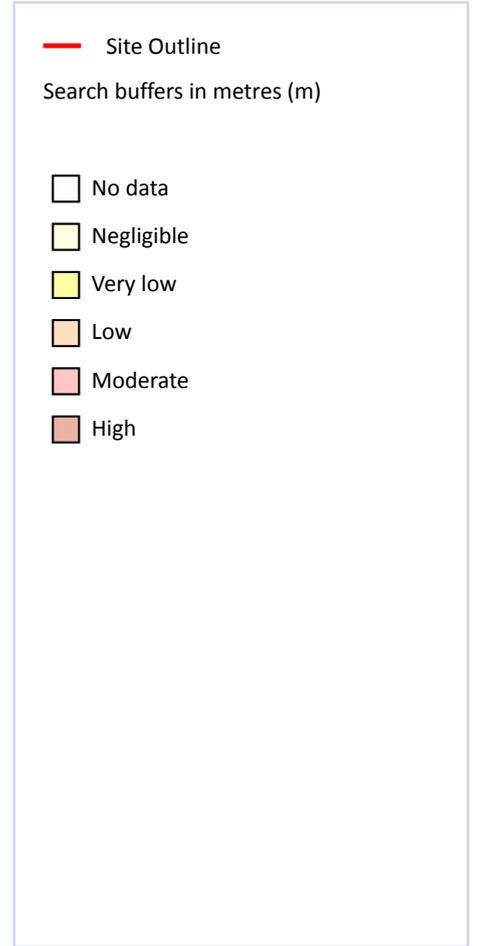
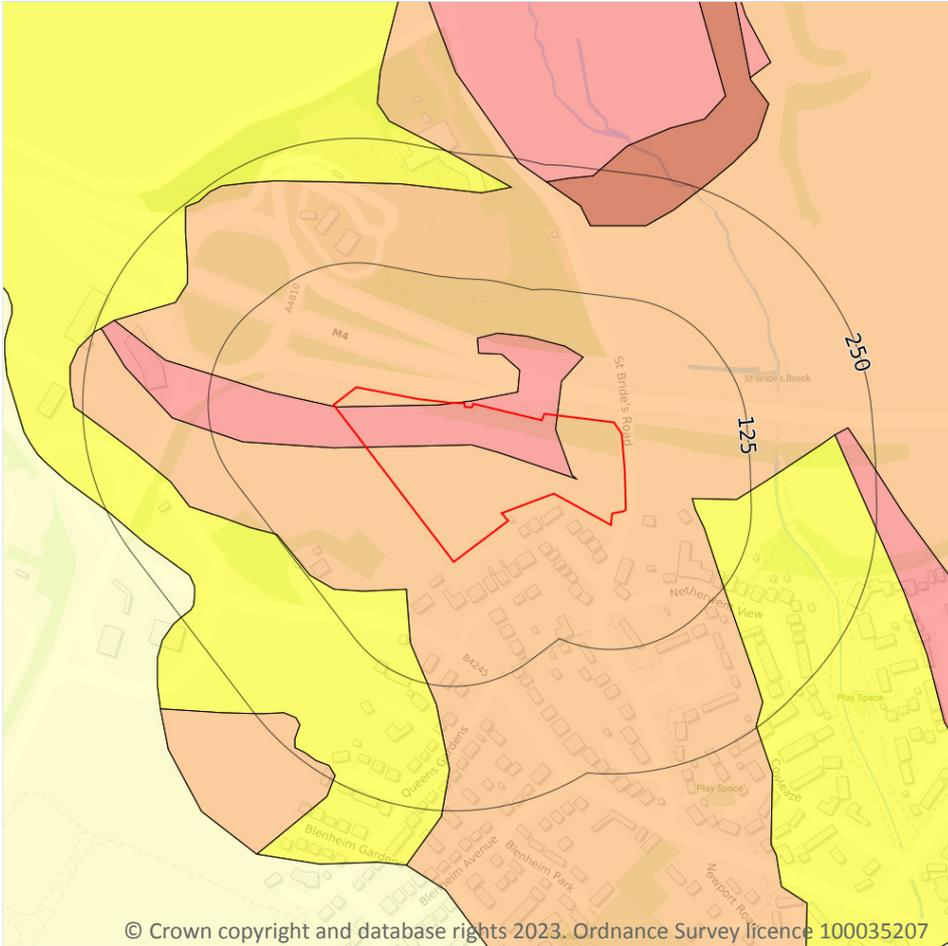

© Crown copyright and database rights 2023. Ordnance Survey licence 100035207

### 17.6 Ground dissolution of soluble rocks

Records within 50m

2

The potential hazard presented by ground dissolution, which occurs when water passing through soluble rocks produces underground cavities and cave systems. These cavities reduce support to the ground above and can cause localised collapse of the overlying rocks and deposits.

Features are displayed on the Natural ground subsidence - Ground dissolution of soluble rocks map on [page 96](#)

>

Location	Hazard rating	Details
On site	Low	Soluble rocks are present within the ground. Some dissolution features may be present. Potential for difficult ground conditions are at a level where they may be considered, localised subsidence need not be considered except in exceptional circumstances.

Location	Hazard rating	Details
On site	Moderate	Soluble rocks are present within the ground. Many dissolution features may be present. Potential for difficult ground conditions are at a level where they should be considered. Potential for subsidence is at a level where it may need to be considered.

*This data is sourced from the British Geological Survey.*

## 18 Mining and ground workings

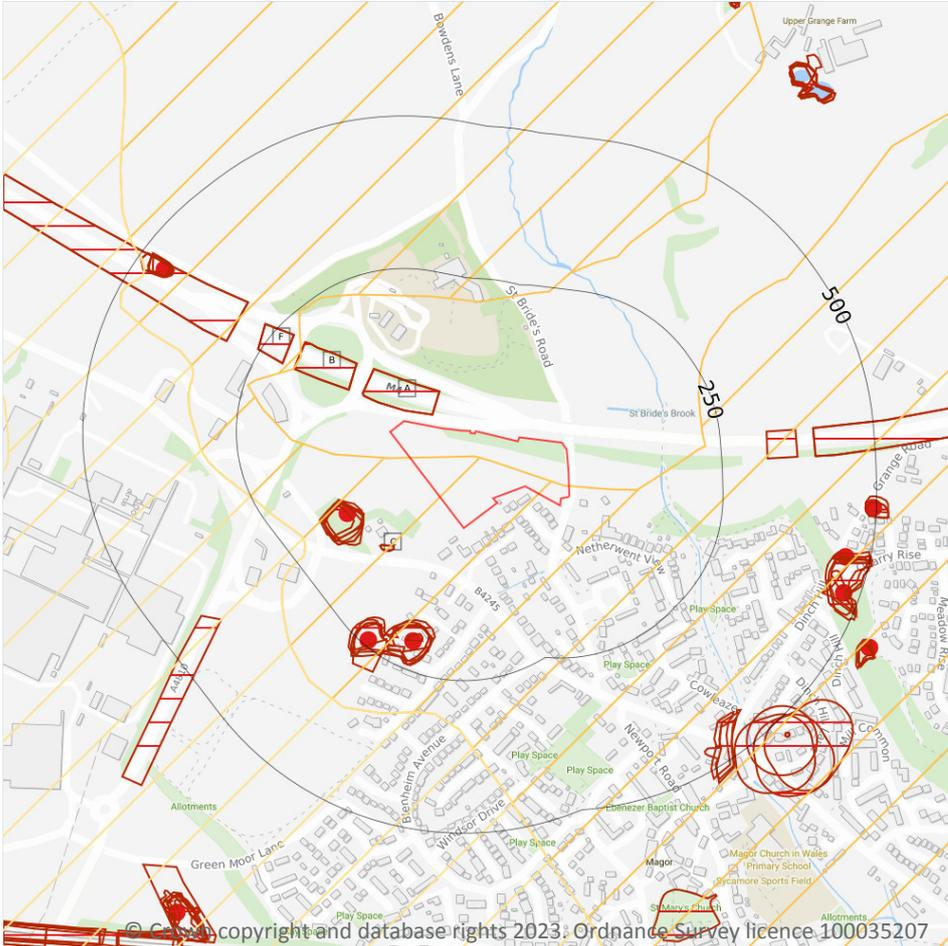

### 18.1 BritPits

#### Records within 500m

7

BritPits (an abbreviation of British Pits) is a database maintained by the British Geological Survey of currently active and closed surface and underground mineral workings. Details of major mineral handling sites, such as wharfs and rail depots are also held in the database.

Features are displayed on the Mining and ground workings map on [page 98](#) >

ID	Location	Details	Description
D	136m W	Name: The Elms Address: Magor, NEWPORT, Monmouthshire Commodity: Limestone Status: Ceased	Type: A surface mineral working. It may be termed Quarry, Sand Pit, Clay Pit or Opencast Coal Site Status description: Site which, at date of entry, has ceased to extract minerals. May be considered as Closed by operator. May be considered to have Active, Dormant or Expired planning permissions by Mineral Planning Authority
E	203m S	Name: The Laurels Address: Magor, NEWPORT, Monmouthshire Commodity: Limestone Status: Ceased	Type: A surface mineral working. It may be termed Quarry, Sand Pit, Clay Pit or Opencast Coal Site Status description: Site which, at date of entry, has ceased to extract minerals. May be considered as Closed by operator. May be considered to have Active, Dormant or Expired planning permissions by Mineral Planning Authority
E	240m SW	Name: The Laurels Address: Magor, NEWPORT, Monmouthshire Commodity: Limestone Status: Ceased	Type: A surface mineral working. It may be termed Quarry, Sand Pit, Clay Pit or Opencast Coal Site Status description: Site which, at date of entry, has ceased to extract minerals. May be considered as Closed by operator. May be considered to have Active, Dormant or Expired planning permissions by Mineral Planning Authority
G	453m NW	Name: Wilcrick Hill Address: Wilcrick, NEWPORT, Monmouthshire Commodity: Limestone Status: Ceased	Type: A surface mineral working. It may be termed Quarry, Sand Pit, Clay Pit or Opencast Coal Site Status description: Site which, at date of entry, has ceased to extract minerals. May be considered as Closed by operator. May be considered to have Active, Dormant or Expired planning permissions by Mineral Planning Authority
I	460m E	Name: The Dancing Place Address: Magor, NEWPORT, Monmouthshire Commodity: Dolomite Status: Ceased	Type: A surface mineral working. It may be termed Quarry, Sand Pit, Clay Pit or Opencast Coal Site Status description: Site which, at date of entry, has ceased to extract minerals. May be considered as Closed by operator. May be considered to have Active, Dormant or Expired planning permissions by Mineral Planning Authority
I	473m E	Name: Dinch Hill Address: Magor, NEWPORT, Monmouthshire Commodity: Dolomite Status: Ceased	Type: A surface mineral working. It may be termed Quarry, Sand Pit, Clay Pit or Opencast Coal Site Status description: Site which, at date of entry, has ceased to extract minerals. May be considered as Closed by operator. May be considered to have Active, Dormant or Expired planning permissions by Mineral Planning Authority

ID	Location	Details	Description
L	494m E	Name: The Cedars Address: Magor, NEWPORT, Monmouthshire Commodity: Dolomite Status: Ceased	Type: A surface mineral working. It may be termed Quarry, Sand Pit, Clay Pit or Opencast Coal Site Status description: Site which, at date of entry, has ceased to extract minerals. May be considered as Closed by operator. May be considered to have Active, Dormant or Expired planning permissions by Mineral Planning Authority

This data is sourced from the British Geological Survey.

## 18.2 Surface ground workings

<b>Records within 250m</b>	<b>22</b>
----------------------------	-----------

Historical land uses identified from Ordnance Survey mapping that involved ground excavation at the surface. These features may or may not have been subsequently backfilled.

Features are displayed on the Mining and ground workings map on [page 98 >](#)

ID	Location	Land Use	Year of mapping	Mapping scale
A	17m NW	Cuttings	1988	1:10000
A	17m NW	Cuttings	1969	1:10560
B	97m NW	Cuttings	1988	1:10000
B	97m NW	Cuttings	1969	1:10560
C	109m SW	Unspecified Ground Workings	1922	1:10560
C	109m SW	Unspecified Ground Workings	1922	1:10560
D	115m W	Unspecified Old Quarries	1963	1:10560
D	115m W	Unspecified Ground Workings	1988	1:10000
D	118m W	Unspecified Ground Workings	1969	1:10560
D	118m W	Unspecified Old Quarries	1949	1:10560
D	118m W	Unspecified Old Quarries	1919	1:10560
D	125m SW	Unspecified Quarry	1881	1:10560
D	135m SW	Unspecified Old Quarries	1902	1:10560
E	166m S	Unspecified Old Quarries	1922	1:10560
E	173m S	Unspecified Old Quarries	1963	1:10560
E	174m S	Unspecified Ground Workings	1969	1:10560



ID	Location	Land Use	Year of mapping	Mapping scale
E	176m S	Unspecified Old Quarries	1949	1:10560
E	177m S	Unspecified Old Quarries	1902	1:10560
E	187m S	Unspecified Pit	1881	1:10560
E	207m SW	Unspecified Pit	1881	1:10560
F	208m NW	Cuttings	1988	1:10000
F	208m NW	Cuttings	1969	1:10560

*This data is sourced from Ordnance Survey/Groundsure.*

### 18.3 Underground workings

**Records within 1000m**

**0**

Historical land uses identified from Ordnance Survey mapping that indicate the presence of underground workings e.g. mine shafts.

*This data is sourced from Ordnance Survey/Groundsure.*

### 18.4 Underground mining extents

**Records within 500m**

**0**

This data identifies underground mine workings that could present a potential risk, including adits and seam workings. These features have been identified from BGS Geological mapping and mine plans sourced from the BGS and various collections and sources.

*This data is sourced from Groundsure.*

### 18.5 Historical Mineral Planning Areas

**Records within 500m**

**0**

Boundaries of mineral planning permissions for England and Wales. This data was collated between the 1940s (and retrospectively to the 1930s) and the mid 1980s. The data includes permitted, withdrawn and refused permissions.

*This data is sourced from the British Geological Survey.*



## 18.6 Non-coal mining

### Records within 1000m

**2**

The potential for historical non-coal mining to have affected an area. The assessment is drawn from expert knowledge and literature in addition to the digital geological map of Britain. Mineral commodities may be divided into seven general categories - vein minerals, chalk, oil shale, building stone, bedded ores, evaporites and 'other' commodities (including ball clay, jet, black marble, graphite and chert).

Features are displayed on the Mining and ground workings map on [page 98 >](#)

ID	Location	Name	Commodity	Class	Likelihood
1	On site	Not available	Vein Mineral	B	<b>Underground mine workings may have occurred in the past or current mines may be working at significant depth to modern engineering standards. Potential for difficult ground conditions are unlikely and are at a level where they need not be considered.</b>
2	218m W	Not available	Vein Mineral	A	Underground mine workings are uncommon, although the geology is similar to that worked elsewhere. Potential for difficult ground conditions are unlikely and are at a level where they need not be considered.

*This data is sourced from the British Geological Survey.*

## 18.7 JPB mining areas

### Records on site

**0**

Areas which could be affected by former coal and other mining. This data includes some mine plans unavailable to the Coal Authority.

*This data is sourced from Johnson Poole and Bloomer.*

## 18.8 The Coal Authority non-coal mining

### Records within 500m

**0**

This data provides an indication of the potential zone of influence of recorded underground non-coal mining workings. Any and all analysis and interpretation of Coal Authority Data in this report is made by Groundsure, and is in no way supported, endorsed or authorised by the Coal Authority. The use of the data is restricted to the terms and provisions contained in this report. Data reproduced in this report may be the copyright of the Coal Authority and permission should be sought from Groundsure prior to any re-use.

*This data is sourced from The Coal Authority.*



## 18.9 Researched mining

Records within 500m

0

This data indicates areas of potential mining identified from alternative or archival sources, including; BGS Geological paper maps, Lidar data, aerial photographs (from World War II onwards), archaeological data services, websites, Tithe maps, and various text/plans from collected books and reports. Some of this data is approximate and Groundsure have interpreted the resultant risk area and, where possible, specific areas of risk have been captured.

*This data is sourced from Groundsure.*

## 18.10 Mining record office plans

Records within 500m

0

This dataset is representative of Mining Record Office and/or plan extents held by Groundsure and should be considered approximate. Where possible, plans have been located and any specific areas of risk they depict have been captured.

*This data is sourced from Groundsure.*

## 18.11 BGS mine plans

Records within 500m

0

This dataset is representative of BGS mine plans held by Groundsure and should be considered approximate. Where possible, plans have been located and any specific areas of risk they depict have been captured.

*This data is sourced from Groundsure.*

## 18.12 Coal mining

Records on site

0

Areas which could be affected by past, current or future coal mining.

*This data is sourced from the Coal Authority.*

## 18.13 Brine areas

Records on site

0

The Cheshire Brine Compensation District indicates areas that may be affected by salt and brine extraction in Cheshire and where compensation would be available where damage from this mining has occurred. Damage from salt and brine mining can still occur outside this district, but no compensation will be available.

*This data is sourced from the Cheshire Brine Subsidence Compensation Board.*



### 18.14 Gypsum areas

Records on site	0
-----------------	---

Generalised areas that may be affected by gypsum extraction.

*This data is sourced from British Gypsum.*

### 18.15 Tin mining

Records on site	0
-----------------	---

Generalised areas that may be affected by historical tin mining.

*This data is sourced from Groundsure.*

### 18.16 Clay mining

Records on site	0
-----------------	---

Generalised areas that may be affected by kaolin and ball clay extraction.

*This data is sourced from the Kaolin and Ball Clay Association (UK).*

## 19 Ground cavities and sinkholes

### 19.1 Natural cavities

Records within 500m

0

Industry recognised national database of natural cavities. Sinkholes and caves are formed by the dissolution of soluble rock, such as chalk and limestone, gulls and fissures by cambering. Ground instability can result from movement of loose material contained within these cavities, often triggered by water.

*This data is sourced from Stantec UK Ltd.*

### 19.2 Mining cavities

Records within 1000m

0

Industry recognised national database of mining cavities. Degraded mines may result in hazardous subsidence (crown holes). Climatic conditions and water escape can also trigger subsidence over mine entrances and workings.

*This data is sourced from Stantec UK Ltd.*

### 19.3 Reported recent incidents

Records within 500m

0

This data identifies sinkhole information gathered from media reports and Groundsure's own records. This data goes back to 2014 and includes relative accuracy ratings for each event and links to the original data sources. The data is updated on a regular basis and should not be considered a comprehensive catalogue of all sinkhole events. The absence of data in this database does not mean a sinkhole definitely has not occurred during this time.

*This data is sourced from Groundsure.*

### 19.4 Historical incidents

Records within 500m

0

This dataset comprises an extract of 1:10,560, 1:10,000, 1:2,500 and 1:1,250 scale historical Ordnance Survey maps held by Groundsure, dating back to the 1840s. It shows shakeholes, deneholes and other 'holes' as noted on these maps. Dene holes are medieval chalk extraction pits, usually comprising a narrow shaft with a number of chambers at the base of the shaft. Shakeholes are an alternative name for suffusion sinkholes, most commonly found in the limestone landscapes of North Yorkshire but also extensively noted around the Brecon Beacons National Park.

Not all 'holes' noted on Ordnance Survey mapping will necessarily be present within this dataset.



*This data is sourced from Groundsure.*

## 19.5 National karst database

Records within 500m

0

This is a comprehensive database of national karst information gathered from a wide range of sources. BGS have collected data on five main types of karst feature: Sinkholes, stream links, caves, springs, and incidences of associated damage to buildings, roads, bridges and other engineered works.

Since the database was set up in 2002 data covering most of the evaporite karst areas of the UK have now been added, along with data covering about 60% of the Chalk, and 35% of the Carboniferous Limestone outcrops. Many of the classic upland karst areas have yet to be included. Recorded so far are: Over 800 caves, 1300 stream sinks, 5600 springs, 10,000 sinkholes.

The database is not yet complete, and not all records have been verified. The absence of data does not mean that karst features are not present at a site. A reliability rating is included with each record.

*This data is sourced from the British Geological Survey.*



## 20 Radon

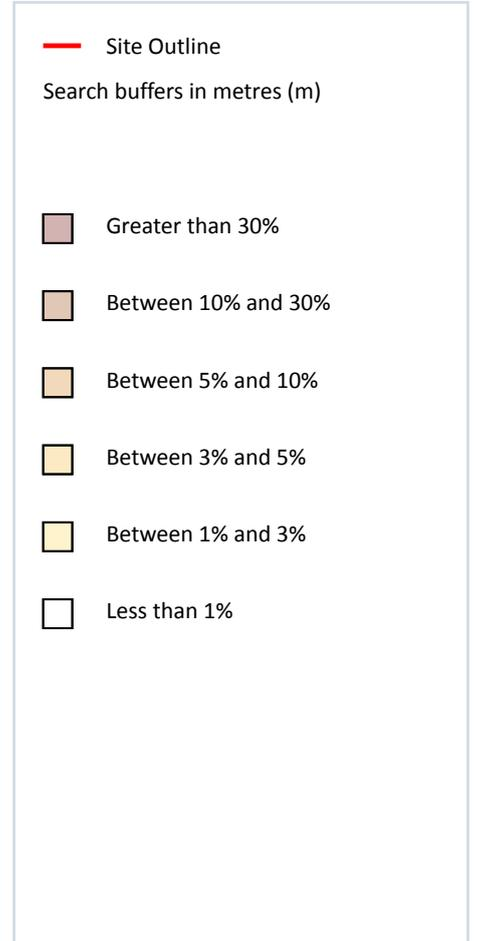
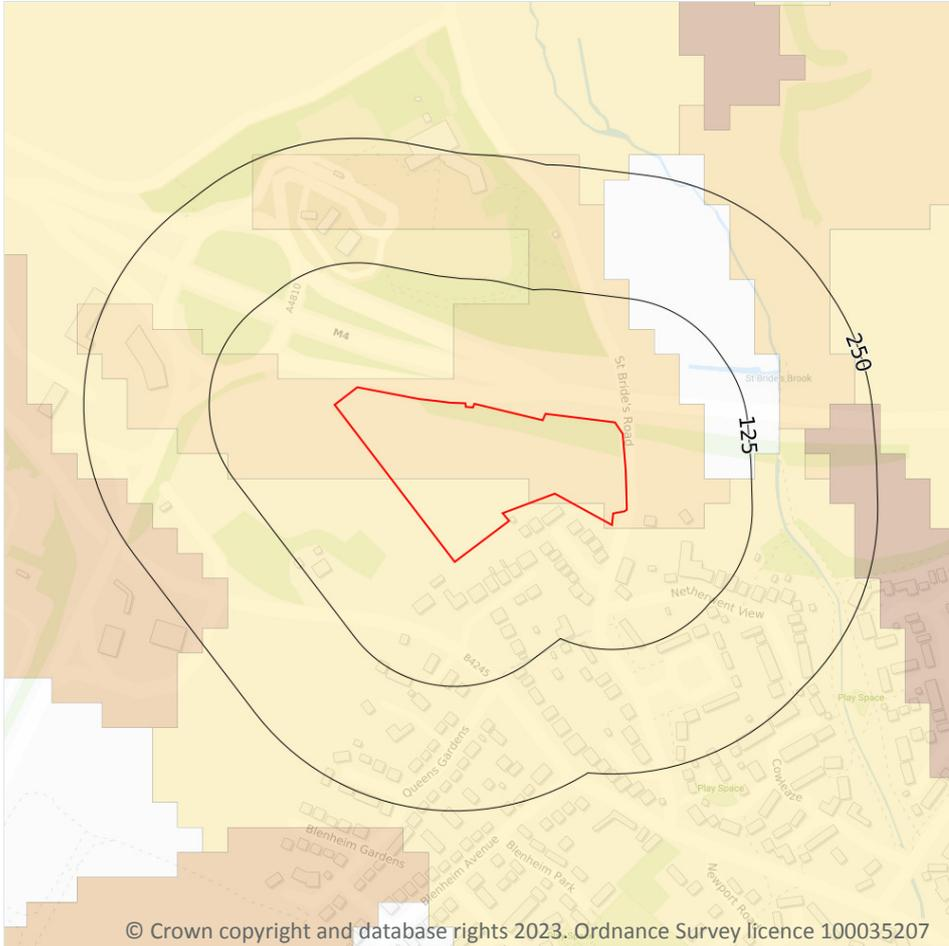

### 20.1 Radon

#### Records on site

2

The Radon Potential data classifies areas based on their likelihood of a property having a radon level at or above the Action Level in Great Britain. The dataset is intended for use at 1:50,000 scale and was derived from both geological assessments and indoor radon measurements (more than 560,000 records). A minimum 50m buffer should be considered when searching the maps, as the smallest detectable feature at this scale is 50m. The findings of this section should supersede any estimations derived from the Indicative Atlas of Radon in Great Britain (1:100,000 scale).

Features are displayed on the Radon map on [page 107](#) >

Location	Estimated properties affected	Radon Protection Measures required
On site	Between 3% and 5%	Basic

Location	Estimated properties affected	Radon Protection Measures required
<b>On site</b>	<b>Between 1% and 3%</b>	<b>None</b>

*This data is sourced from the British Geological Survey and UK Health Security Agency.*

## 21 Soil chemistry

### 21.1 BGS Estimated Background Soil Chemistry

Records within 50m

6

The estimated values provide the likely background concentration of the potentially harmful elements Arsenic, Cadmium, Chromium, Lead and Nickel in topsoil. The values are estimated primarily from rural topsoil data collected at a sample density of approximately 1 per 2 km<sup>2</sup>. In areas where rural soil samples are not available, estimation is based on stream sediment data collected from small streams at a sampling density of 1 per 2.5 km<sup>2</sup>; this is the case for most of Scotland, Wales and southern England. The stream sediment data are converted to soil-equivalent concentrations prior to the estimation.

Location	Arsenic	Bioaccessible Arsenic	Lead	Bioaccessible Lead	Cadmium	Chromium	Nickel
On site	15 - 25 mg/kg	No data	100 mg/kg	60 mg/kg	1.8 mg/kg	60 - 90 mg/kg	15 - 30 mg/kg
On site	15 mg/kg	No data	100 mg/kg	60 mg/kg	1.8 mg/kg	60 - 90 mg/kg	15 - 30 mg/kg
On site	15 mg/kg	No data	100 mg/kg	60 mg/kg	1.8 mg/kg	60 - 90 mg/kg	15 - 30 mg/kg
On site	15 mg/kg	No data	100 mg/kg	60 mg/kg	1.8 mg/kg	60 - 90 mg/kg	15 - 30 mg/kg
On site	15 mg/kg	No data	100 mg/kg	60 mg/kg	1.8 mg/kg	60 - 90 mg/kg	15 - 30 mg/kg
38m NE	15 mg/kg	No data	100 mg/kg	60 mg/kg	1.8 mg/kg	60 - 90 mg/kg	15 - 30 mg/kg

*This data is sourced from the British Geological Survey.*

### 21.2 BGS Estimated Urban Soil Chemistry

Records within 50m

0

Estimated topsoil chemistry of Arsenic, Cadmium, Chromium, Copper, Nickel, Lead, Tin and Zinc and bioaccessible Arsenic and Lead in 23 urban centres across Great Britain. These estimates are derived from interpolation of the measured urban topsoil data referred to above and provide information across each city between the measured sample locations (4 per km<sup>2</sup>).

*This data is sourced from the British Geological Survey.*





## 21.3 BGS Measured Urban Soil Chemistry

Records within 50m

0

The locations and measured total concentrations (mg/kg) of Arsenic, Cadmium, Chromium, Copper, Nickel, Lead, Tin and Zinc in urban topsoil samples from 23 urban centres across Great Britain. These are collected at a sample density of 4 per km<sup>2</sup>.

*This data is sourced from the British Geological Survey.*



## 22 Railway infrastructure and projects

### 22.1 Underground railways (London)

Records within 250m 0

Details of all active London Underground lines, including approximate tunnel roof depth and operational hours.

*This data is sourced from publicly available information by Groundsure.*

### 22.2 Underground railways (Non-London)

Records within 250m 0

Details of the Merseyrail system, the Tyne and Wear Metro and the Glasgow Subway. Not all parts of all systems are located underground. The data contains location information only and does not include a depth assessment.

*This data is sourced from publicly available information by Groundsure.*

### 22.3 Railway tunnels

Records within 250m 0

Railway tunnels taken from contemporary Ordnance Survey mapping.

*This data is sourced from the Ordnance Survey.*

### 22.4 Historical railway and tunnel features

Records within 250m 0

Railways and tunnels digitised from historical Ordnance Survey mapping as scales of 1:1,250, 1:2,500, 1:10,000 and 1:10,560.

*This data is sourced from Ordnance Survey/Groundsure.*

### 22.5 Royal Mail tunnels

Records within 250m 0

The Post Office Railway, otherwise known as the Mail Rail, is an underground railway running through Central London from Paddington Head District Sorting Office to Whitechapel Eastern Head Sorting Office. The line is 10.5km long. The data includes details of the full extent of the tunnels, the depth of the tunnel, and the depth to track level.

*This data is sourced from Groundsure/the Postal Museum.*

## 22.6 Historical railways

Records within 250m	0
---------------------	---

Former railway lines, including dismantled lines, abandoned lines, disused lines, historic railways and razed lines.

*This data is sourced from OpenStreetMap.*

## 22.7 Railways

Records within 250m	0
---------------------	---

Currently existing railway lines, including standard railways, narrow gauge, funicular, trams and light railways.

*This data is sourced from Ordnance Survey and OpenStreetMap.*

## 22.8 Crossrail 1

Records within 500m	0
---------------------	---

The Crossrail railway project links 41 stations over 100 kilometres from Reading and Heathrow in the west, through underground sections in central London, to Shenfield and Abbey Wood in the east.

*This data is sourced from publicly available information by Groundsure.*

## 22.9 Crossrail 2

Records within 500m	0
---------------------	---

Crossrail 2 is a proposed railway linking the national rail networks in Surrey and Hertfordshire via an underground tunnel through London.

*This data is sourced from publicly available information by Groundsure.*

## 22.10 HS2

Records within 500m	0
---------------------	---

HS2 is a proposed high speed rail network running from London to Manchester and Leeds via Birmingham. Main civils construction on Phase 1 (London to Birmingham) of the project began in 2019, and it is currently anticipated that this phase will be fully operational by 2026. Construction on Phase 2a (Birmingham to Crewe) is anticipated to commence in 2021, with the service fully operational by 2027. Construction on Phase 2b (Crewe to Manchester and Birmingham to Leeds) is scheduled to begin in 2023 and be operational by 2033.

*This data is sourced from HS2 Ltd.*



## Data providers

Groundsure works with respected data providers to bring you the most relevant and accurate information. To find out who they are and their areas of expertise see <https://www.groundsure.com/sources-reference> ↗.

## Terms and conditions

Groundsure's Terms and Conditions can be accessed at this link: [www.groundsure.com/terms-and-conditions-april-2023/](http://www.groundsure.com/terms-and-conditions-april-2023/) ↗.



## **B. Historical Borehole Logs**

**BOREHOLE LOG**

BOREHOLE N° 65

GROUND LEVEL : 36.1

TYPE OF BORING: Power Auger.

DATE STARTED : 5.7.62

DIA OF BORING: 6"

DESCRIPTION	THICKNESS	DEPTH	LEGEND	SAMPLE N°	N° OF BLOWS OR LOAD	LABORATORY TESTS	TOOLS USED
Firm red-brown sandy silty CLAY very sandy in places.	16' 6"	0' 0"	X	• 1	6 tons.	Tu	Power Auger.
		X	• 2				
		X	• 3				
		X	• 4				
		X	• 5				
		X	• 6				
		X	• 7				
		X	• 8				
		X	• 9				
		X	• 10				
Compact SAND and GRAVEL (f.m.c)	8' 6"	16' 6"	X	+ 8	80 blows/ft.		
		25' 0"	X	+ 9	70 blows/5"		

REMARKS:

KEY TO LABORATORY TESTS			LONDON - SOUTH WALES MOTORWAY COLDRA - CRICK.
W = MOISTURE CONTENT; S = SIEVE ANALYSIS; H = FULL MECH-ANICAL ANALYSIS; A = PLASTICITY INDEX; P = DRY DENSITY/MOISTURE RELATION; Td = DRAINED TRIAXIAL; Tu = UNDRAINED TRIAXIAL; Rd = REMOULDED DRAINED TRIAXIAL; Ru = REMOULDED UNDRAINED TRIAXIAL; K = C.B.R. (UNSOAKED); Ks = C.B.R. (SOAKED); C = CONSOLIDATION; U = UNCONFINED COMPRESSION TEST; B = SHEAR BOX			
KEY TO SAMPLES.	UNDISTURBED SAMPLE	DISTURBED SAMPLE	FOUNDATION ENGINEERING LIMITED; 111, WESTMINSTER BRIDGE ROAD, LONDON, S.E. 1.
CORE BORING % RECOVERY	+ S.P.T. No. of BLOWS	WATER LEVEL	

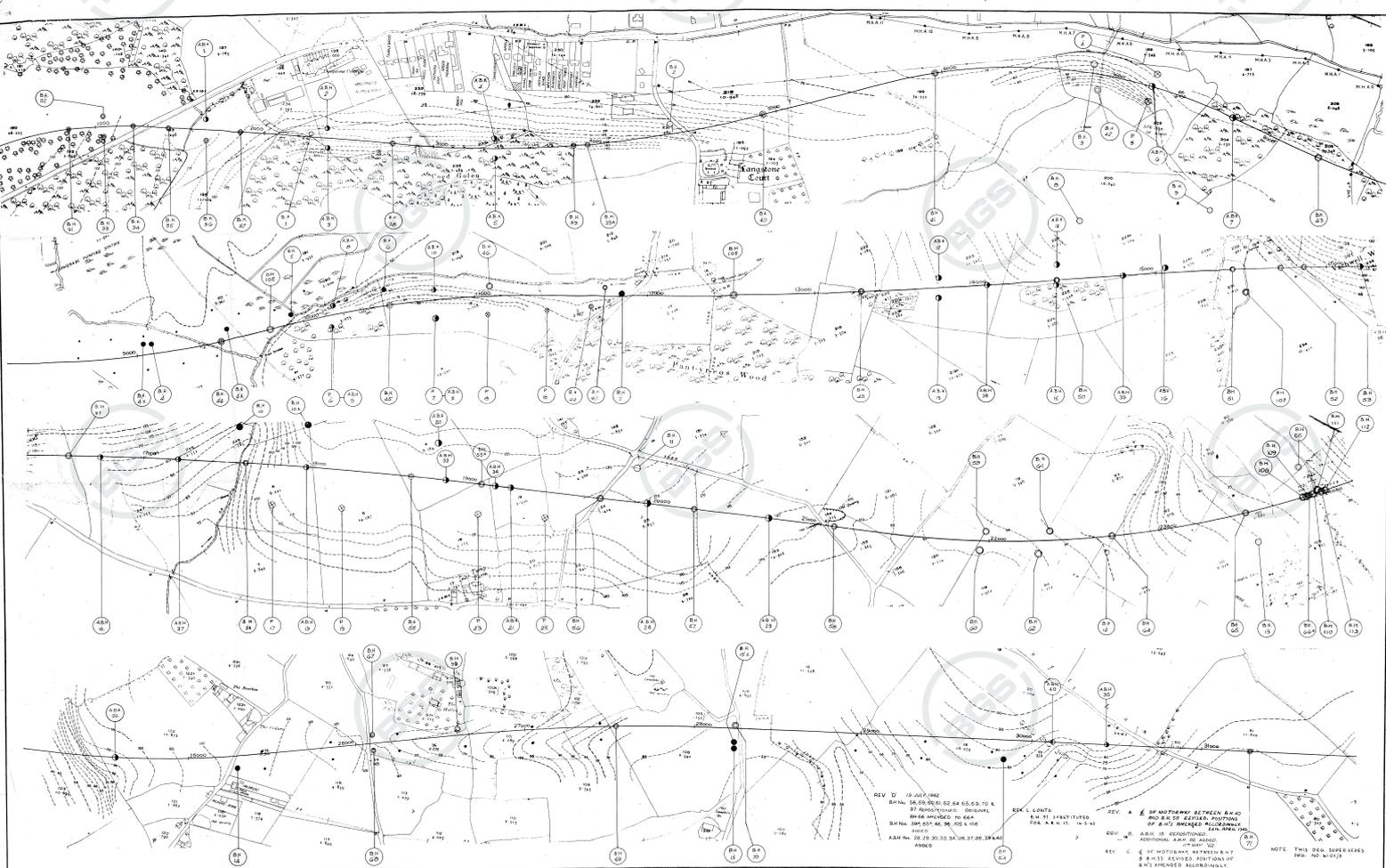

LONDON — SOUTH WALES MOTORWAY CRICK — EAST OF CHRISTCHURCH SPECIAL ROAD	SECOND SOIL SURVEY - BOREHOLE AND PROBE POSITIONS SHEET 1	G. MAUNSELL & PARTNERS, (CONSULTING ENGINEERS) WESTMINSTER, S.W.1.	SCALE 1:2500 DATE 15 APR 2002 DRG. No. 601/5
--	---	--	---

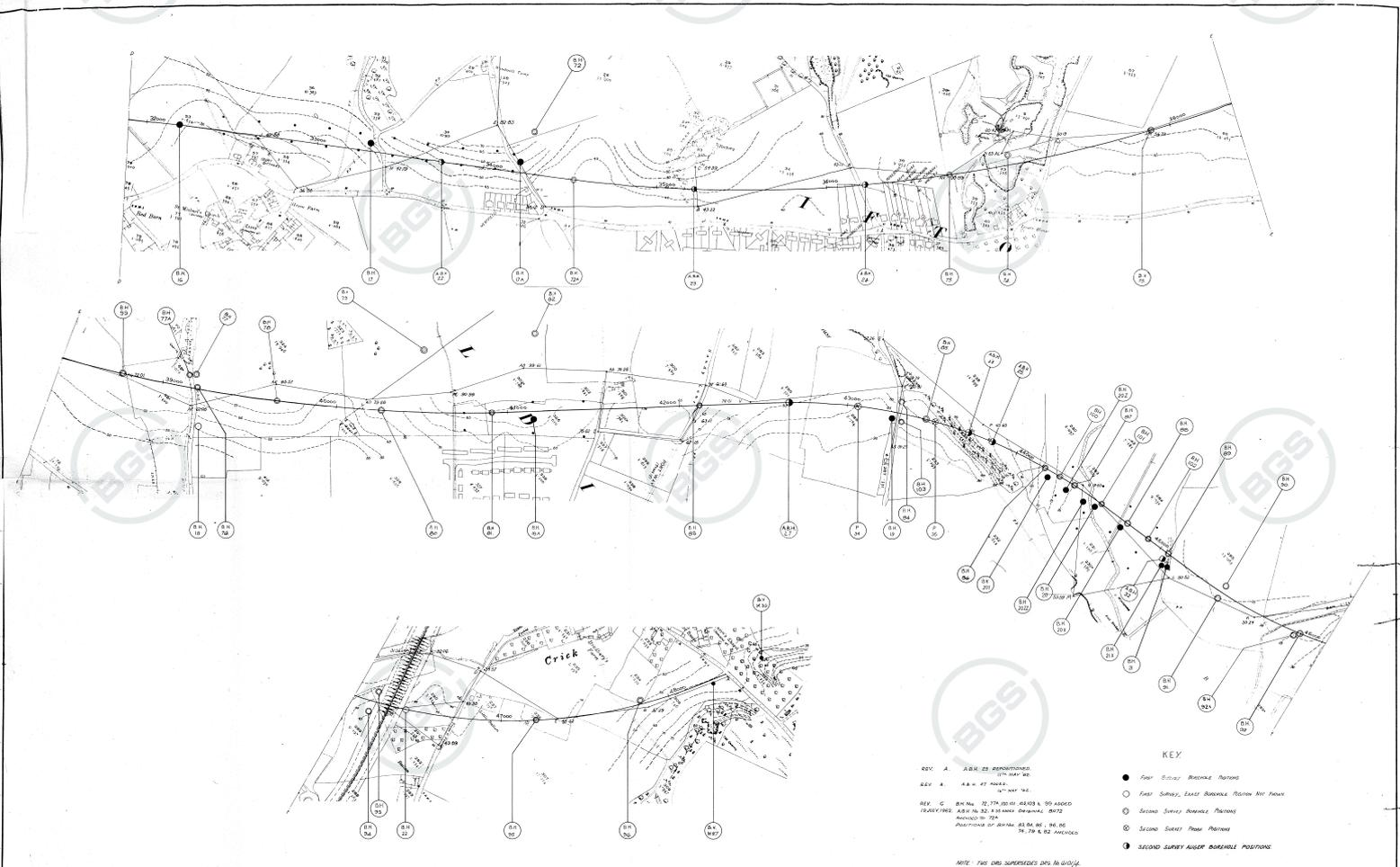

LONDON - SOUTH WALES MOTORWAY CRICK - EAST OF CHRISTCHURCH SPECIAL ROAD	SECOND SOIL SURVEY - BOREHOLE AND PROBE POSITIONS SHEET 2	G. MAUNSELL & PARTNERS, CONSULTING ENGINEERS WESTMINSTER, S.W.1.	SCALE 1/2500 DATE: 14/11/02 DRG. No. 610/16°
--	---	--	--



ST48NW, 28

Methods		Dates	Job No.	Borehole No.	Sheet	
Cable tool boring 150mm dia. from G.L to 3.50m. Rotary coring 92mm dia. from 3.50 10.00m using air/mist flush and mylar.		22/03/90 - 29/03/90	7625	7108	1 of 1	
		Coordinates	Site			
		[REDACTED]	SECOND SEVERN CROSSING Main Onshore Ground Investigation			
		Ground Level	Client			
		12.90 mOD	Department of Transport.			
Depth m	Sample/Test	Field Records	Level mOD	Depth m (Thick)	Description	Legend
			12.80	0.10	TOPSOIL	[Symbol]
0.50 - 1.00	B 1				Firm brown sandy CLAY with some subangular fine to coarse limestone gravel. (TERRACE DEPOSITS)	[Symbol]
1.00 - 1.50	B 2			(1.80)		[Symbol]
1.20 - 1.65	SPT N(12)	2,3/3,4,2,3				[Symbol]
1.50 - 2.00	B 3					[Symbol]
2.20 - 2.65	SPT D 4	N(9)	11.00	1.90	Loose to medium dense orange brown limestone GRAVEL with much sand. (TERRACE DEPOSITS)	[Symbol]
2.20 - 2.65				(1.10)		[Symbol]
2.70 - 3.20	B 5					[Symbol]
3.00 - 3.30	SPT D 6	N(61*)	9.90	3.00	Recovered as non intact fragments of moderately weathered LIMESTONE very strong, moderately weathered CONGLOMERATE very strong and brown moderately weathered SANDSTONE strong. (Possible TERRACE DEPOSITS)	[Symbol]
3.00 - 3.30						[Symbol]
3.50 - 3.50	SPT N(50*)	50 for no pen.,/,,				[Symbol]
	TCR	SCR	RQD	If		
					Coring started at 3.50m.	
	17	0	0		(4.50)	
6.50					CPT: 50 no pen.	
	25	0	0			
7.50					Assessed zone of core loss.	
	0	0	0	NA	(2.50)	
10.00						
					CPT: 3,2/2, 50 for 75mm	
			2.90	10.00		
Remarks					Scale	1:50
1. Inspection pit to 1.20m. 2. Chiselling, 3.00 to 3.50m, 1 hr. 3. Borehole backfilled with bentonite/cement grout on completion.					Logged by	JL/GW
See key sheet for symbols and abbreviations					200890/1038	



ST48NW128

Type of Installation:  Internal Diameter of Pipes:  Diameter of Filter Zone:				<b>Borehole No.</b> 7108					
				<b>Job No.</b> 7625					
				<b>Site</b> SECOND SEVERN CROSSING Main Onshore Ground Investigation					
				<b>Client</b> Department of Transport.					
				Groundwater Observations during Drilling					
Level mOD	Depth m	Legend	Description	Date	Time	Depth Hole m	Depth Casing m	Depth Water m	Remarks
				22/03/90		3.50	3.40	DRY	Start of coring BH complete
				29/03/90	1000	3.50	3.00	DRY	
				29/03/90	1915	10.00	3.00	DRY	
				Instrument Type (A):					
				Groundwater Observations					
				Date	Time	Depth m	Level mOD	Remarks	
				Notes					
Remarks									
								Logged by JL/GW	

**BOREHOLE LOG**

BOREHOLE No 64.

GROUND LEVEL : 70.3

TYPE OF BORING: Power Auger -  
Diamond Drill.

DATE STARTED : 19.7.62

DIA OF BORING: 6" and 2 7/8"

DESCRIPTION	THICKNESS	DEPTH	LEGEND	SAMPLE No	No of BLOWS OR LOAD.	LABORATORY TESTS	TOOLS USED.
Firm brown CLAY and boulders of limestone.	3' 6"	0'0" to 3'6"		• 1			Power Auger.
LIMESTONE.	6' 6" +	3'6" to 10'0"					Diamond Drill.

REMARKS:

<p><b>KEY TO LABORATORY TESTS</b></p> <p>W = MOISTURE CONTENT ; S = SIEVE ANALYSIS ; H = FULL MECH -ANICAL ANALYSIS ; A = PLASTICITY INDEX ; P = DRY DENSITY / MOISTURE RELATION ; T<sub>d</sub> = DRAINED TRIAXIAL ; T<sub>u</sub> = UNDRAINED TRIAXIAL ; R<sub>d</sub> = REMOULDED DRAINED TRIAXIAL ; R<sub>u</sub> = REMOULDED UNDRAINED TRIAXIAL ; K = C.B.R. (UNSOAKED) ; K<sub>s</sub> = C.B.R. (SOAKED) ; C = CONSOLIDATION ; U = UNCONFINED COMPRESSION TEST ; B = SHEAR BOX</p>		<p>LONDON - SOUTH WALES MOTORWAY COLDRA - CRICK.</p>
--	--	--

<p>KEY TO SAMPLES.</p> <p> CORE BORING % RECOVERY</p>	<p> UNDISTURBED SAMPLE</p> <p> DISTURBED SAMPLE</p>	<p>FOUNDATION ENGINEERING LIMITED ; 111, WESTMINSTER BRIDGE ROAD, LONDON S. E. 1.</p>
---	---	---

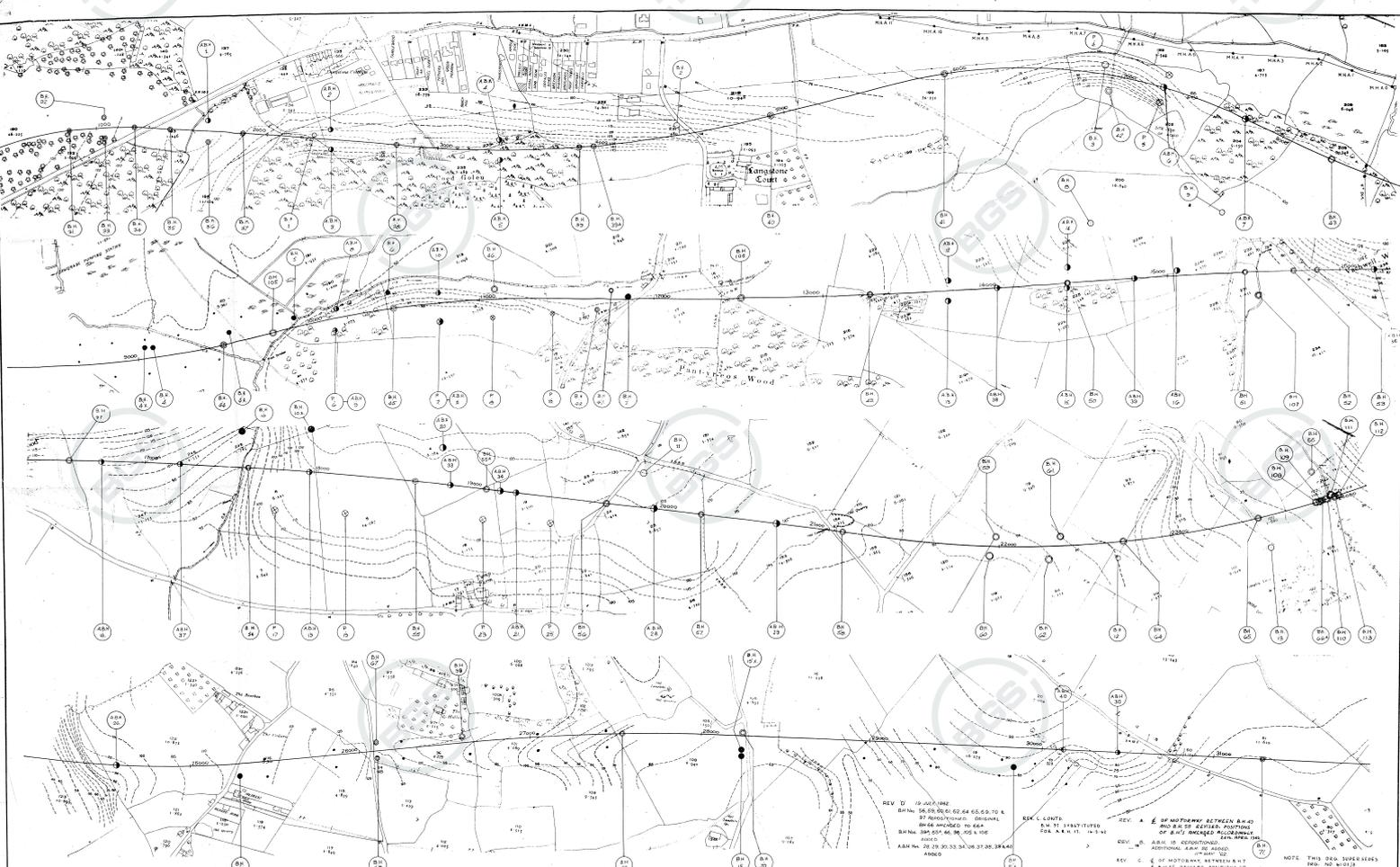

LONDON — SOUTH WALES MOTORWAY CRICK — EAST OF CHRISTCHURCH SPECIAL ROAD	SECOND SOIL SURVEY - BOREHOLE AND PROBE POSITIONS SHEET 1	G. MAUNSELL & PARTNERS, CONSULTING ENGINEERS WESTMINSTER, S.W.1 SCALE 1:2500 DATE 15 APR 2002 DRG. No. 601/5
--	---	--

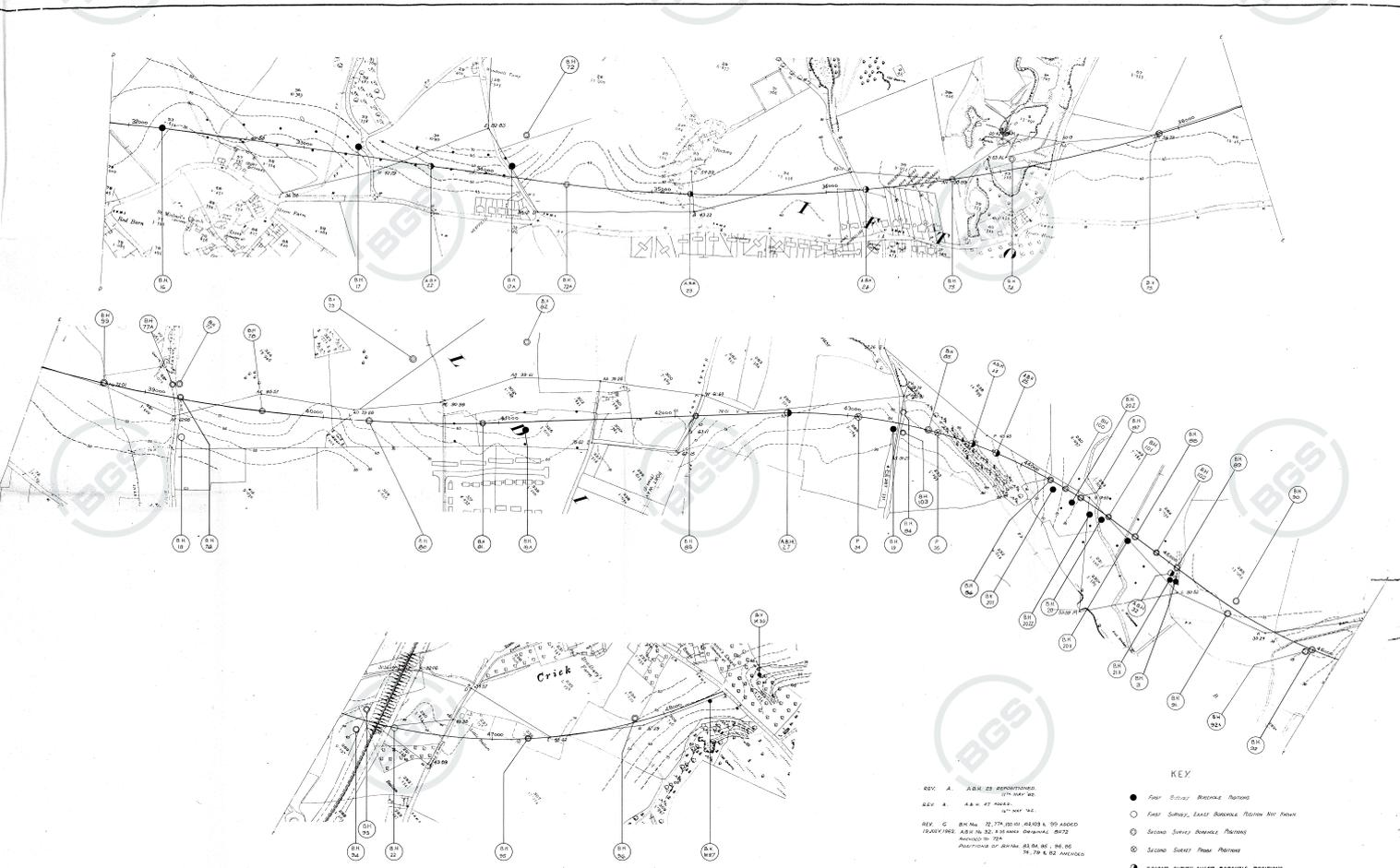

LONDON — SOUTH WALES MOTORWAY  
CRICK — EAST OF CHRISTCHURCH SPECIAL ROAD

SECOND SOIL SURVEY — BOREHOLE AND PROBE POSITIONS SHEET 2

G. MAUNSELL & PARTNERS,  
CONSULTING ENGINEERS  
WESTMINSTER, S.W.1.

SCALE 1/2500 DATE 14/7/61  
DRG. No. 610/69

ST48NW 29

Methods		Dates		Job No.		Borehole No.	
Cable tool boring 150mm dia. from G.L to 7.50m. Rotary coring 92mm dia. and open holing 143mm dia. from 7.50 to 9.80m using air/mist flush and mylar.		22/03/90 - 30/03/90		7625		7109	
		Coordinates		Site			
		Ground Level		Client			
		11.30 mOD		Department of Transport.			
Depth m	Sample/Test	Field Records	Level mOD	Depth m (Thick)	Description	Legend	
0.20 - 0.70	B 1			(0.70)	Firm brown gravelly CLAY. (MADE GROUND)		
0.70 - 1.20	B 2		10.60	0.70	Loose brown fine SAND. (TERRACE DEPOSITS)		
1.20 - 1.65 1.20 - 1.65	SPT D 3	N(9) 2,2/2,2,2,3		(1.10)			
1.70 - 2.20	B 4		9.50	1.80	Firm brown very sandy CLAY with a little to some subrounded gravel. (TERRACE DEPOSITS)		
2.20 - 2.65 2.20 - 2.65	SPT D 5	N(6) 2,1/1,2,1,2		(2.00)			
3.80 - 4.25 3.80 - 4.25	SPT D 6	N(11) 1,2/3,2,2,4	7.50	3.80	Medium dense brown subrounded to subangular GRAVEL with some clayey sand. (TERRACE DEPOSITS)		
4.30 - 4.90	B 7						
4.90 - 5.35 4.90 - 5.35	SPT D 8	N(12) 3,3/3,3,3,3		(3.20)			
6.00 - 6.45 6.00 - 6.45	SPT D 9	N(15) 2,3/3,4,4,4					
7.00 - 7.43 7.00 7.00 7.00 - 7.43 7.50 - 7.58 7.50 - 9.00	SPT W 11 W 13 D 10 SPT B 12	N(75*) 8,10/ 12,13,19,31 for 50mm N(50*) 50,/,...	4.30	7.00	Probably very dense light brown subangular to subrounded sandstone and limestone gravel with some sand and occasional cobbles. (TERRACE DEPOSITS)		
			2.30	9.00	Probable bedrock.		
				(0.80)			
			1.50	9.80			
Remarks						Scale	
1. Inspection pit to 1.20m. 2. Water added 3.80 to 7.50m. 3. Chiselling, 4.40 to 4.70m, 0.75 hrs 4. Chiselling, 6.60 to 7.50m, 2.50 hrs 5. Started coring at 7.00m. Barrel stuck inside casing. On pulling casing hole collapsed to 4.90m. cased to 6.50m and open holed to 9.80m. Hole terminated at 9.80m. 6. Borehole backfilled with bentonite/cement grout on completion.						1:50	
See key sheet for symbols and abbreviations						200890/1039	
						Logged by	
						JC	



ST48NW/29

Type of Installation:  Internal Diameter of Pipes:  Diameter of Filter Zone:				Borehole No. 7109					
				Job No. 7625					
				Site SECOND SEVERN CROSSING Main Onshore Ground Investigation					
				Client Department of Transport.					
Level mOD	Depth m	Legend	Description	Groundwater Observations during Drilling					
				Date	Time	Depth Hole m	Depth Casing m	Depth Water m	Remarks
				22/03/90	1800	3.00	3.00	DRY	
				23/03/90	0800	3.00	3.00	2.60	
				23/03/90		3.80	3.20	0.00	Water added
				23/03/90		7.50	6.90	0.00	
				29/03/90	1205	7.00	7.00	2.65	Start of coring
				29/03/90	1835	9.80	7.00	2.90	
				30/03/90	0800	9.80	7.50	3.05	BH complete
				Instrument Type (A):					
				Groundwater Observations					
				Date	Time	Depth m	Level mOD	Remarks	
				Notes					
Remarks									

**BOREHOLE LOG**

BOREHOLE N° 108

GROUND LEVEL : 33

TYPE OF BORING: Shell and Auger.

DATE STARTED : 17.10.62.

DIA OF BORING: 6"

DESCRIPTION	THICKNESS	DEPTH	LEGEND	SAMPLE N°	N° OF BLOWS OR LOAD.	LABORATORY TESTS	TOOLS USED.
Red brown CLAY.	2' 6"	0' 0" - 2' 6"		• 1			
Loose brown sandy CLAY.	2' 3"	2' 6" - 4' 9"		• 2 • 3	17	T <sub>u</sub>	
Grey silty CLAY.	2' 0"	4' 9" - 6' 9"	X	• 4	blows/ft.		
Grey sandy CLAY.	6' 9"	6' 9" - 13' 6"		• 5			
Hard CLAY with sandstone.	0' 6"	13' 6" - 14' 0"		• 6			

REMARKS:

<p><b>KEY TO LABORATORY TESTS</b></p> <p>W = MOISTURE CONTENT; S = SIEVE ANALYSIS; H = FULL MECH - ANICAL ANALYSIS; A = PLASTICITY INDEX; P = DRY DENSITY / MOISTURE RELATION; T<sub>d</sub> = DRAINIED TRIAXIAL; T<sub>u</sub> = UNDRAINED TRIAXIAL; R<sub>d</sub> = REMOULDED DRAINIED TRIAXIAL; R<sub>u</sub> = REMOULDED UNDRAINED TRIAXIAL; K = C.B.R. (UNSOAKED); K<sub>s</sub> = C.B.R. (SOAKED); C = CONSOLIDATION; U = UNOAINED COMPRESSION TEST; B = SHEAR BOX</p>		<p>LONDON - SOUTH WALES MOTORWAY COLDRA - CRICK.</p>
<p>KEY TO SAMPLES.</p> <p>□ CORE BORING % RECOVERY</p>	<p>▬ UNDISTURBED SAMPLE</p> <p>• DISTURBED SAMPLE</p> <p>+ S.P.T. N° OF BLOWS</p> <p>≡ WATER</p>	<p>FOUNDATION ENGINEERING LIMITED; 111, WESTMINSTER BRIDGE ROAD, LONDON, S.E.1.</p>



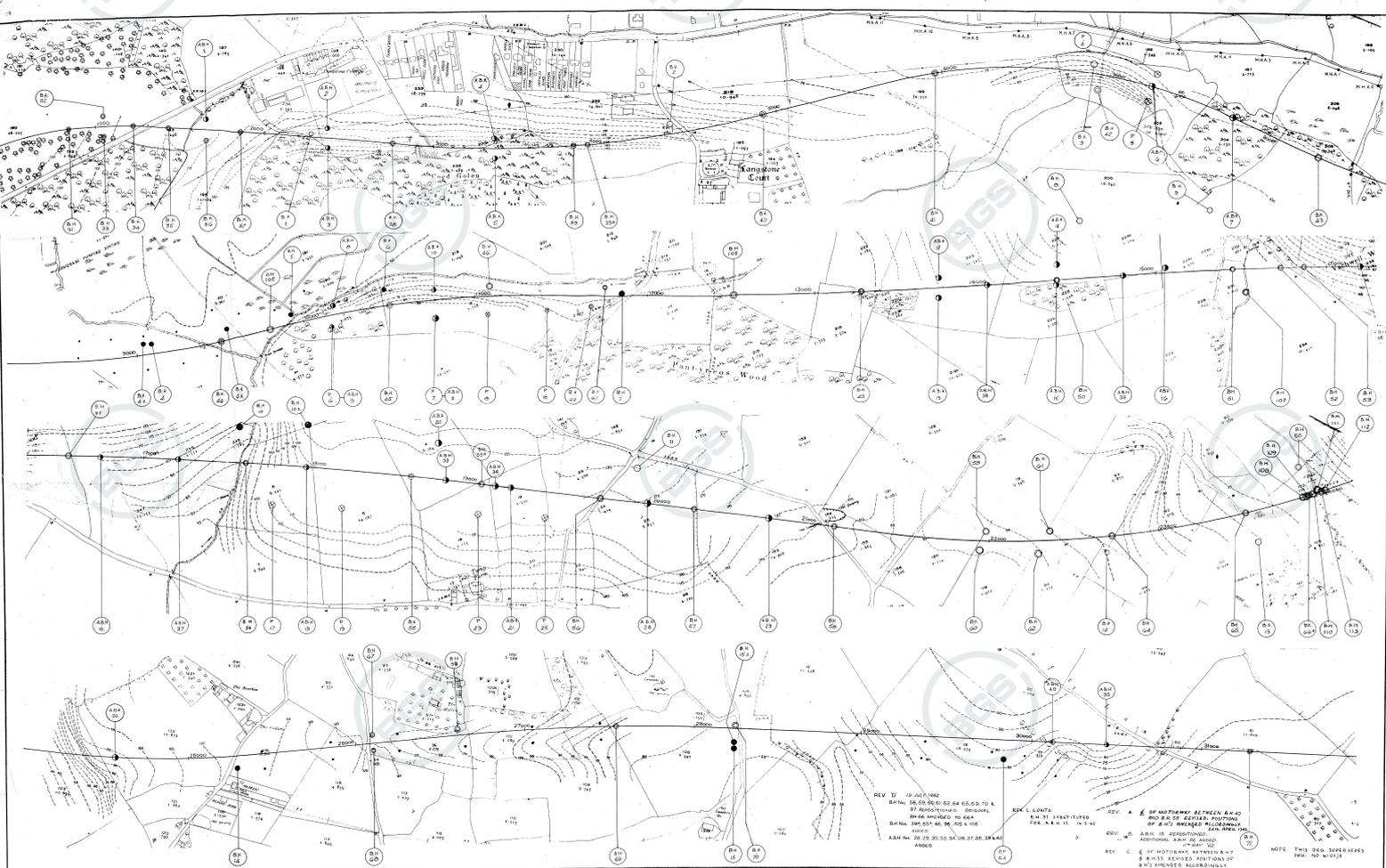

<p>LONDON — SOUTH WALES MOTORWAY CRICK — EAST OF CHRISTCHURCH SPECIAL ROAD</p>	<p>SECOND SOIL SURVEY - BOREHOLE AND PROBE POSITIONS SHEET 1</p>	<p>G. MAUNSELL &amp; PARTNERS, CONSULTING ENGINEERS WESTMINSTER, S.W.1</p> <p>SCALE 1:2500 DATE 15 APR 2002 DRG. No. 601/5<sup>c</sup></p>
--	--	--



**BOREHOLE LOG**

BOREHOLE No 109

GROUND LEVEL : 33

TYPE OF BORING: Shell and Auger.

DATE STARTED : 17.10.62.

DIA OF BORING: 6"

DESCRIPTION	THICKNESS	DEPTH	LEGEND	SAMPLE No	No of BLOWS OR LOAD.	LABORATORY TESTS.	Tools Used.
Firm red brown CLAY.	3' 10"	0' 0" to 3' 10"	[Horizontal lines]	• 1			
Loose sandy CLAY.	1' 5"	3' 10" to 5' 3"	[Dotted pattern]	• 2			
Firm blue SILT with some sand.	2' 9"	5' 3" to 8' 0"	[Cross-hatch pattern]	• 3	17	Tu	
			[Cross-hatch pattern]	• 4	blows/ft.		
Firm blue CLAY with coarse sand.	3' 0" +	8' 0" to 11' 0"	[Dotted pattern]	• 5			
			[Dotted pattern]	• 6			

REMARKS :

<p><b>KEY TO LABORATORY TESTS</b></p> <p>W = MOISTURE CONTENT ; S = SIEVE ANALYSIS ; H = FULL MECH - ANICAL ANALYSIS ; A = PLASTICITY INDEX ; P = DRY DENSITY / MOISTURE RELATION ; T<sub>d</sub> = DRAINER TRIAXIAL ; T<sub>u</sub> = UNDRAINED TRIAXIAL ; R<sub>d</sub> = REMOLDED DRAINER TRIAXIAL ; R<sub>u</sub> = REMOLDED UNDRAINED TRIAXIAL ; K = C.B.R. (UNSOAKED) ; K<sub>s</sub> = C.B.R. (SOAKED) ; C = CONSOLIDATION ; U = UNCONFINED COMPRESSION TEST ; B = SHEAR BOX</p>			<p>LONDON - SOUTH WALES MOTORWAY COLDRA - CRICK.</p>
<p>KEY TO SAMPLES.</p> <p>▬ CORE BORING % RECOVERY</p>	<p>▬ UNDISTURBED SAMPLE</p> <p>• DISTURBED SAMPLE</p>	<p>† S.P.T. No. OF BLOWS</p> <p>▽ WATER LEVEL</p>	<p>FOUNDATION ENGINEERING LIMITED ; 111, WESTMINSTER BRIDGE ROAD, LONDON S. E. 1.</p>

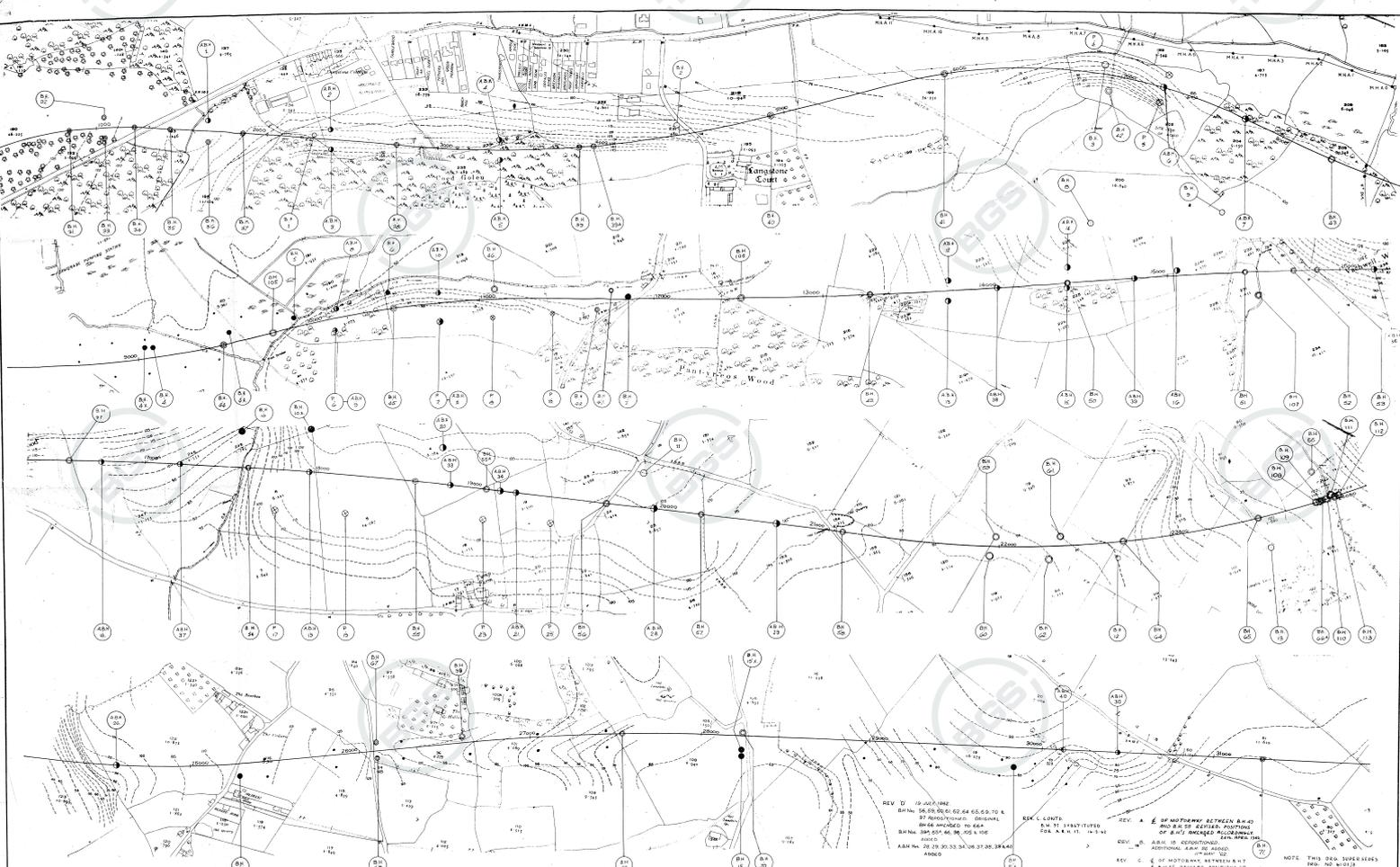

<p>LONDON — SOUTH WALES MOTORWAY CRICK — EAST OF CHRISTCHURCH SPECIAL ROAD</p>	<p>SECOND SOIL SURVEY - BOREHOLE AND PROBE POSITIONS SHEET 1</p>	<p>G. MAUNSELL &amp; PARTNERS, CONSULTING ENGINEERS WESTMINSTER, S.W.1</p> <p>SCALE 1:2500 DATE 15 APR 2002 DRG. No. 601/5<sup>c</sup></p>
--	--	--

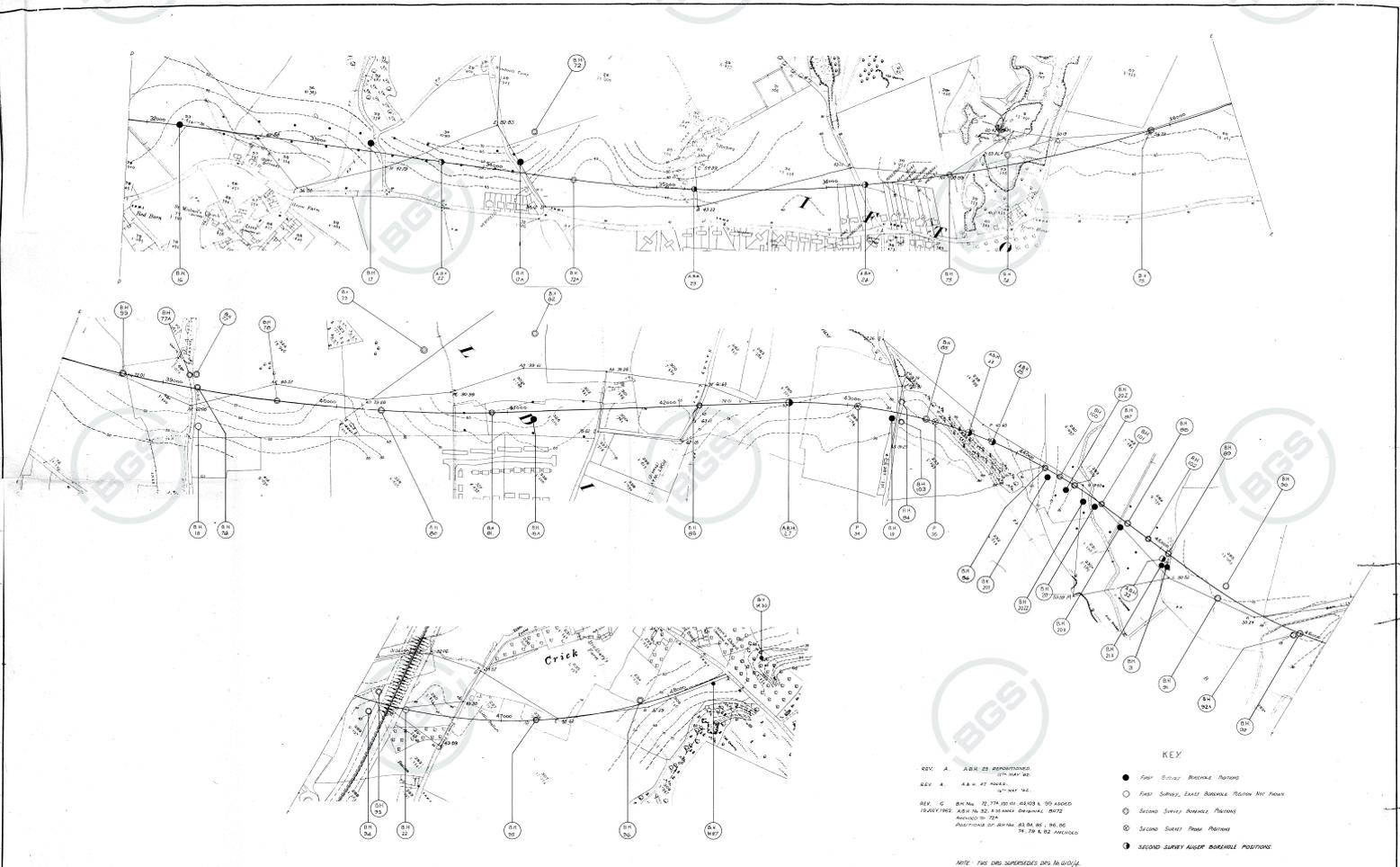

LONDON - SOUTH WALES MOTORWAY CRICK - EAST OF CHRISTCHURCH SPECIAL ROAD	SECOND SOIL SURVEY - BOREHOLE AND PROBE POSITIONS SHEET 2	G. MAUNSELL & PARTNERS, CONSULTING ENGINEERS WESTMINSTER, S.W.1. SCALE 1/2500 DATE: 14/11/04 DRG. No. 610/69
--	---	--

**BOREHOLE LOG**

BOREHOLE N° 66A.

GROUND LEVEL : 32.3

TYPE OF BORING: Shell and Auger.

DATE STARTED : 19.7.62.

DIA OF BORING: 8"

DESCRIPTION	THICKNESS	DEPTH	LEGEND	SAMPLE N°	N° OF BLOWS OR LOAD.	LABORATORY TESTS	TOOLS USED.
TOPSOIL.	1' 0"	0' 0"					
		1' 0"		• 1			
Firm yellow red-brown sandy silty CLAY.			X	• 2			
		4' 0"	X				
Soft blue-grey silty organic CLAY.	3' 0"		X	• 3	25	Tu	Shell and Auger.
		7' 0"	X	• 4	blows/ft.		
			X	• 5			
Soft blue-grey silty sandy CLAY.	3' 0"		X				
		10' 0"	X	• 6	22	Tu	
			X	• 7	blows/ft.		
Soft grey-brown silty sandy CLAY.	4' 0"		X				
		14' 0"	X				
c.m.f. GRAVEL with pieces of sandstone.	2' 0"		○	+ 8	55		
		16' 0"			blows/ft.		
				• 9			
Stiff red-grey CLAY with pieces of sandstone.	5' 0"						
		21' 0"		• 10	110	Tu	
			X	• 11	blows/ft.		
Firm black silty CLAY.	2' 6"		X				
		23' 6"	X				
Stiff red-grey marly silty sandy CLAY with limestone and sandstone	1' 0"		X	+ 12	165		
		25' 0"			blows/ft.		

REMARKS:

KEY TO LABORATORY TESTS			LONDON - SOUTH WALES MOTORWAY COLDRA - CRICK.
W = MOISTURE CONTENT; S = SIEVE ANALYSIS; H = FULL MECH-ANICAL ANALYSIS; A = PLASTICITY INDEX; P = DRY DENSITY/MOISTURE RELATION; T <sub>d</sub> = DRAINED TRIAXIAL; T <sub>u</sub> = UNDRAINED TRIAXIAL; R <sub>d</sub> = REMOLDED DRAINED TRIAXIAL; R <sub>u</sub> = REMOLDED UNDRAINED TRIAXIAL; K = C.B.R. (UNSOAKED); K <sub>s</sub> = C.B.R. (SOAKED); C = CONSOLIDATION; U = UNCONFINED COMPRESSION TEST; B = SHEAR BOX			
KEY TO SAMPLES.	UNDISTURBED SAMPLE	DISTURBED SAMPLE	FOUNDATION ENGINEERING LIMITED; 111, WESTMINSTER BRIDGE ROAD, LONDON, S.E.1.
□ CORE BORING % RECOVERY	+ S.P.T. No of Blows	⊖ WATER	

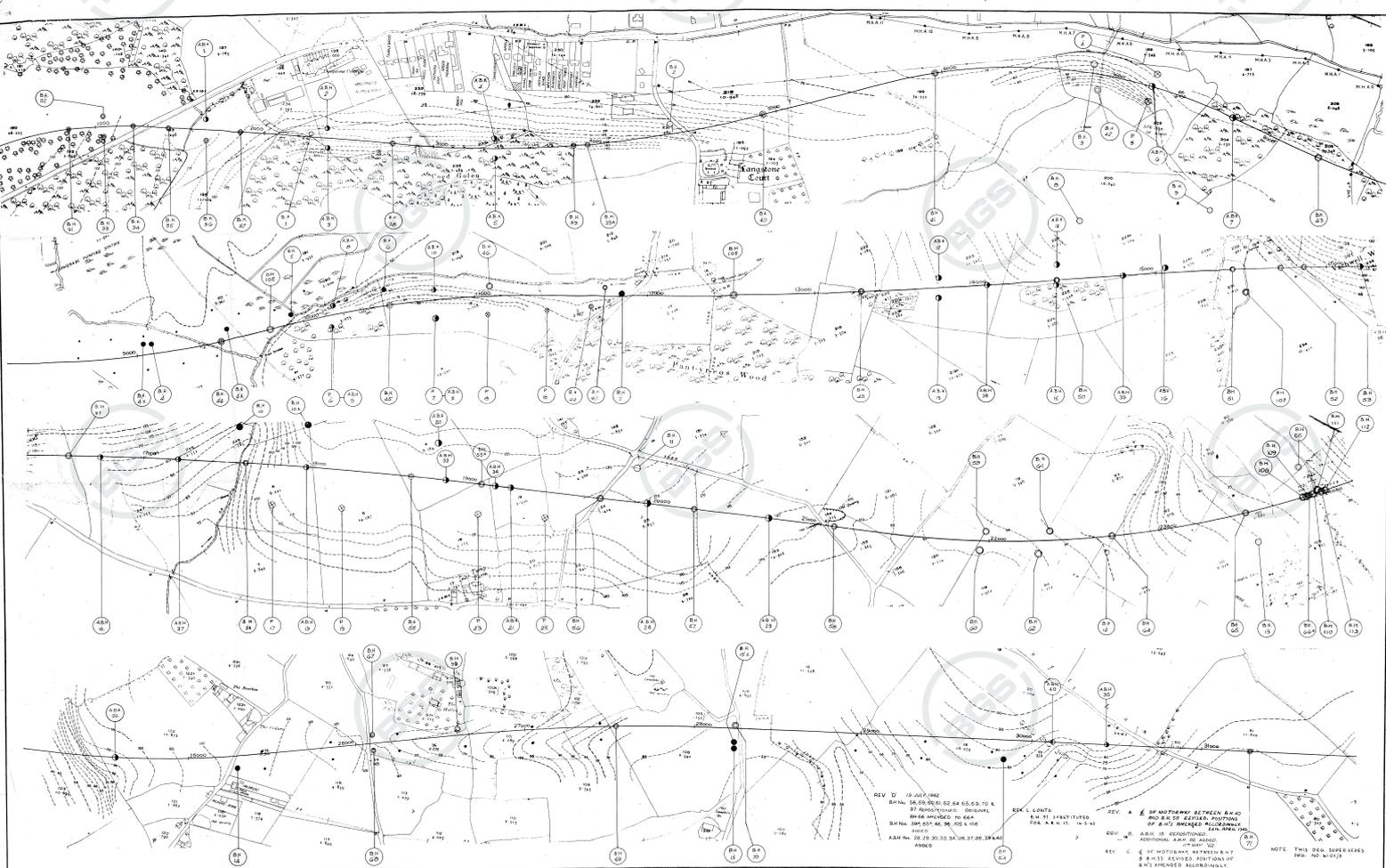

LONDON — SOUTH WALES MOTORWAY  
CRICK — EAST OF CHRISTCHURCH SPECIAL ROAD

SECOND SOIL SURVEY - BOREHOLE AND PROBE POSITIONS SHEET 1

G. MAUNSELL & PARTNERS,  
CONSULTING ENGINEERS  
WESTMINSTER, S.W.1  
SCALE 1:2500 DATE 15 APR 2002  
DRG. No. 601/5<sup>c</sup>

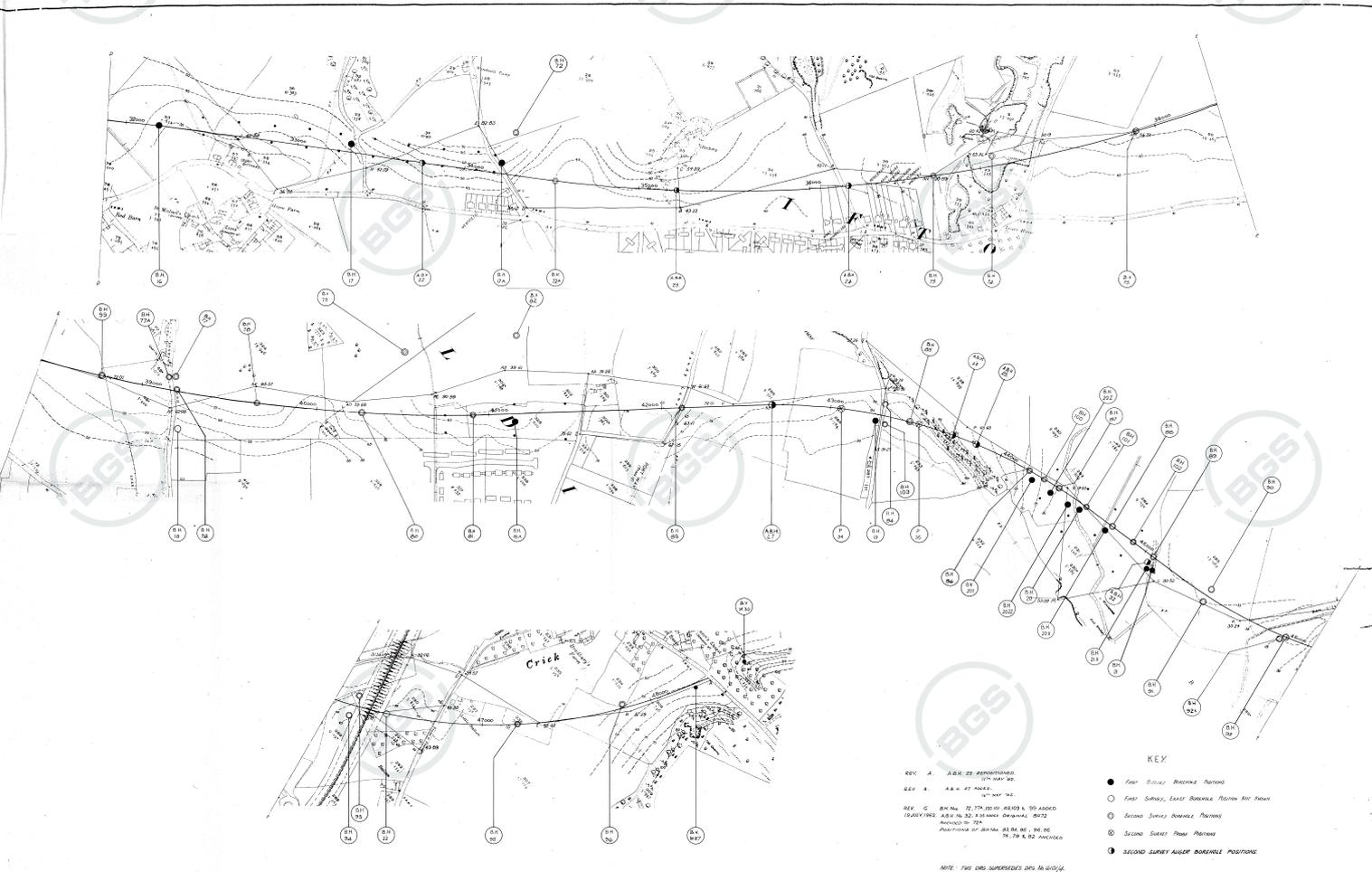

LONDON - SOUTH WALES MOTORWAY CRICK - EAST OF CHRISTCHURCH SPECIAL ROAD	SECOND SOIL SURVEY - BOREHOLE AND PROBE POSITIONS SHEET 2	G. MAUNSELL & PARTNERS, CONSULTING ENGINEERS WESTMINSTER, S.W.1. SCALE 1/2500 DATE: 14/11/02 DRG. No. 610/16°
--	---	--



**BOREHOLE LOG**

BOREHOLE No 61.

GROUND LEVEL : 80.0

TYPE OF BORING: Power Auger -  
Diamond Drill.

DATE STARTED : 14.7.62.

DIA OF BORING: 6" and 2 7/8"

DESCRIPTION	THICKNESS	DEPTH	LEGEND	SAMPLE No	No of BLOWS OR LOAD.	LABORATORY TESTS.	TOOLS USED.
Firm red CLAY slightly silty 8'0" to 9'0"	11'6"	0'0"					Power Auger.
		1'0"		1	8 tons.	P.A.	
		2'0"		2			
		3'0"		3			
SANDSTONE.	1'0"	11'6"	X		5 tons.	P.A.	Diamond Drill.
		12'6"	X	4			
LIMESTONE.	7'6" +	20'0"					

REMARKS:

**KEY TO LABORATORY TESTS**

W = MOISTURE CONTENT; S = SIEVE ANALYSIS; H = FULL MECH-ANICAL ANALYSIS; A = PLASTICITY INDEX; P = DRY DENSITY; MOISTURE RELATION; T<sub>d</sub> = DRAINED TRIAXIAL; T<sub>u</sub> = UNDRAINED TRIAXIAL; R<sub>d</sub> = REMOULDED DRAINED TRIAXIAL; R<sub>u</sub> = REMOULDED UNDRAINED TRIAXIAL; K = C.B.R. (UNSOAKED); K<sub>s</sub> = C.B.R. (SOAKED); C = CONSOLIDATION; U = UNCONFINED COMPRESSION TEST; B = SHEAR BOX

LONDON-SOUTH WALES MOTORWAY  
COLDRA - CRICK.

KEY TO SAMPLES.	UNDISTURBED SAMPLE	DISTURBED SAMPLE
CORE BORING % RECOVERY	S.P.T. No of BLOWS	WATER LEVEL.

FOUNDATION ENGINEERING LIMITED;  
111, WESTMINSTER BRIDGE ROAD,  
LONDON S.E.1.

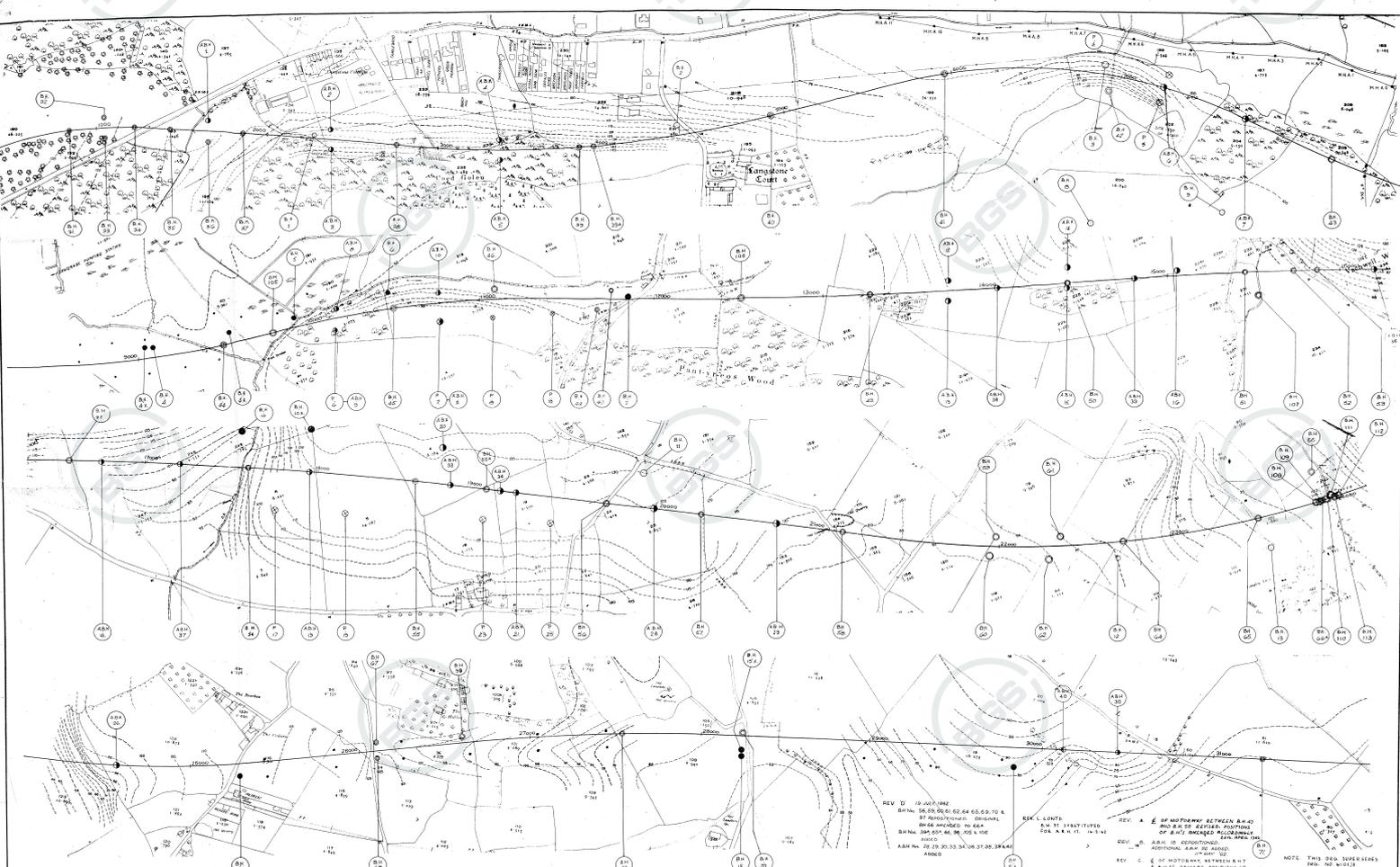

LONDON — SOUTH WALES MOTORWAY CRICK — EAST OF CHRISTCHURCH SPECIAL ROAD	SECOND SOIL SURVEY - BOREHOLE AND PROBE POSITIONS SHEET 1	G. MAUNSELL & PARTNERS, CONSULTING ENGINEERS WESTMINSTER, S.W.1 SCALE 1:2000 DATE 15 JUL 2006 DRG. No. 601/5
--	---	--

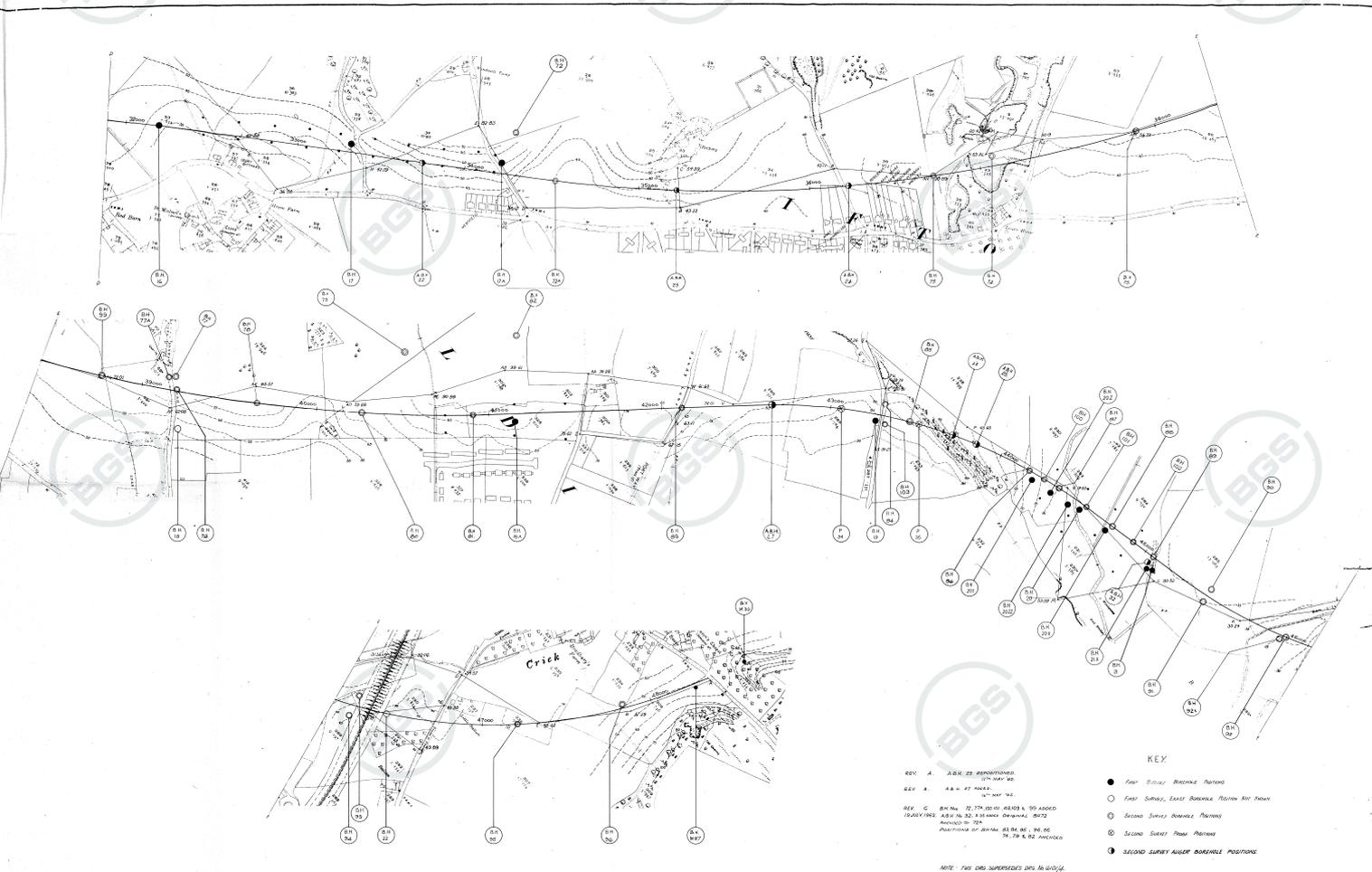

LONDON — SOUTH WALES MOTORWAY  
CRICK — EAST OF CHRISTCHURCH SPECIAL ROAD

SECOND SOIL SURVEY — BOREHOLE AND PROBE POSITIONS SHEET 2

G. MAUNSELL & PARTNERS,  
CONSULTING ENGINEERS  
WESTMINSTER, S.W.1.

SCALE 1/2500 DATE 14/7/61  
DRG. No. 610/69

ST48NW/53

<b>Methods</b> Machine dug to 4.70m by Fiat/Hitachi 130. No support used. Logged on excavated material below 1.20m.		<b>Dates</b> 06/04/90		<b>Job No.</b> 7625	<b>Sheet</b> 1 of 1
		<b>Coordinates</b> 342452 E 187740 N		<b>Site</b> SECOND SEVERN CROSSING Main Onshore Ground Investigation	
		<b>Ground Level</b> 9.73 mOD		<b>Client</b> Department of Transport	
<b>Sample/Test</b>		<b>Level mOD</b>	<b>Depth m (Thick)</b>	<b>Description</b>	<b>Legend</b>
<b>Depth m</b>	<b>Sample/Test</b>				
0.10 - 0.80	B 1	9.63	0.10	TOPSOIL	
0.10	D 2			(0.70)	
0.80 - 1.10	D 3	8.93	0.80	Loose brown slightly clayey medium SAND. From 0.90 to 0.95m, sandy clay. (Probable MADE GROUND)	
1.10	B 4	8.63	1.10	Soft grey CLAY. (ALLUVIUM)	
1.10	D 5			(0.40)	Firm grey CLAY with a little medium gravel. (ALLUVIUM)
1.50	D 6	8.23	1.50	Soft red brown mottled grey sandy CLAY with a little gravel. (ALLUVIUM)	
1.70	D 7	8.03	1.70	Loose grey mottled red brown in parts slightly clayey medium SAND. (ALLUVIUM)	
1.90	D 8			(0.30)	Soft grey very sandy CLAY with a little subangular gravel and occasional red brown clayey sand lenses upto 150mm thick. (ALLUVIUM)
1.90 - 2.00	B 9	7.73	2.00	Dense grey to dark brown clayey sandy rounded GRAVEL with some cobbles. (TERRACE DEPOSITS) From 4.30m, becoming brown and very clayey.	
2.00	D 10			(1.00)	
2.00 - 2.40	B 11	7.33	2.40		
2.40 - 3.40	B 12				
2.40	D 13				
3.40 - 4.30	B 14	6.33	3.40		
4.30 - 4.60	B 15	5.13	4.60		
4.60	D 16			5.03	4.70
<b>Remarks</b>		<b>Plan (Not to scale)</b>			
Insitu Tests: None Groundwater: Not encountered Variability of Faces: None Stability of Faces: Stable Weather: Fine					
See key sheet for symbols and abbreviations		160890/1244		Scale 1:50 Logged by PA	

**BOREHOLE LOG**

BOREHOLE No 110

GROUND LEVEL : 33

TYPE OF BORING: Shell and Auger.

DATE STARTED : 17.10.62

DIA OF BORING: 6"

DESCRIPTION	THICKNESS	DEPTH	LEGEND	SAMPLE No	No of BLOWS OR LOGS	LABORATORY TESTS	TOOLS USED
Red brown CLAY.	4' 0"	0' 0" to 4' 0"	[Horizontal lines]				
Loose sandy CLAY.	2' 0"	4' 0" to 6' 0"	[Horizontal lines]	.1			
Firm blue SILT with some sand.	1' 6"	6' 0" to 7' 6"	[X's]	.2			
Soft blue SILT.	3' 0" +	7' 6" to 10' 6"	[X's]	.3			
			[X's]	.4			

REMARKS: Attempted U4<sup>s</sup> at 4' 0" and 7' 6"

<p><b>KEY TO LABORATORY TESTS</b></p> <p>W = MOISTURE CONTENT; S = SIEVE ANALYSIS; H = FULL MECH - ANICAL ANALYSIS; A = PLASTICITY INDEX; P = DRY DENSITY; MOISTURE RELATION; T<sub>d</sub> = DRAINED TRIAXIAL; T<sub>u</sub> = UNDRAINED TRIAXIAL; R<sub>d</sub> = REMOULDED DRAINED TRIAXIAL; R<sub>u</sub> = REMOULDED UNDRAINED TRIAXIAL; K = C.B.R. (UNSOAKED); K<sub>s</sub> = C.B.R. (SOAKED); C = CONSOLIDATION; U = UNCONFINED COMPRESSION TEST; B = SHEAR BOX</p>		<p>LONDON - SOUTH WALES MOTORWAY COLDRA - CRICK.</p>
---	--	--

<p>KEY TO SAMPLES.</p> <p>▬ UNDISTURBED SAMPLE</p> <p>● DISTURBED SAMPLE</p>	<p>+ S.P.T. No of BLOWS</p>	<p>≡ WATER LEVEL</p>	<p>FOUNDATION ENGINEERING LIMITED; 111, WESTMINSTER BRIDGE ROAD, LONDON, S.E.1.</p>
--	-----------------------------	----------------------	---

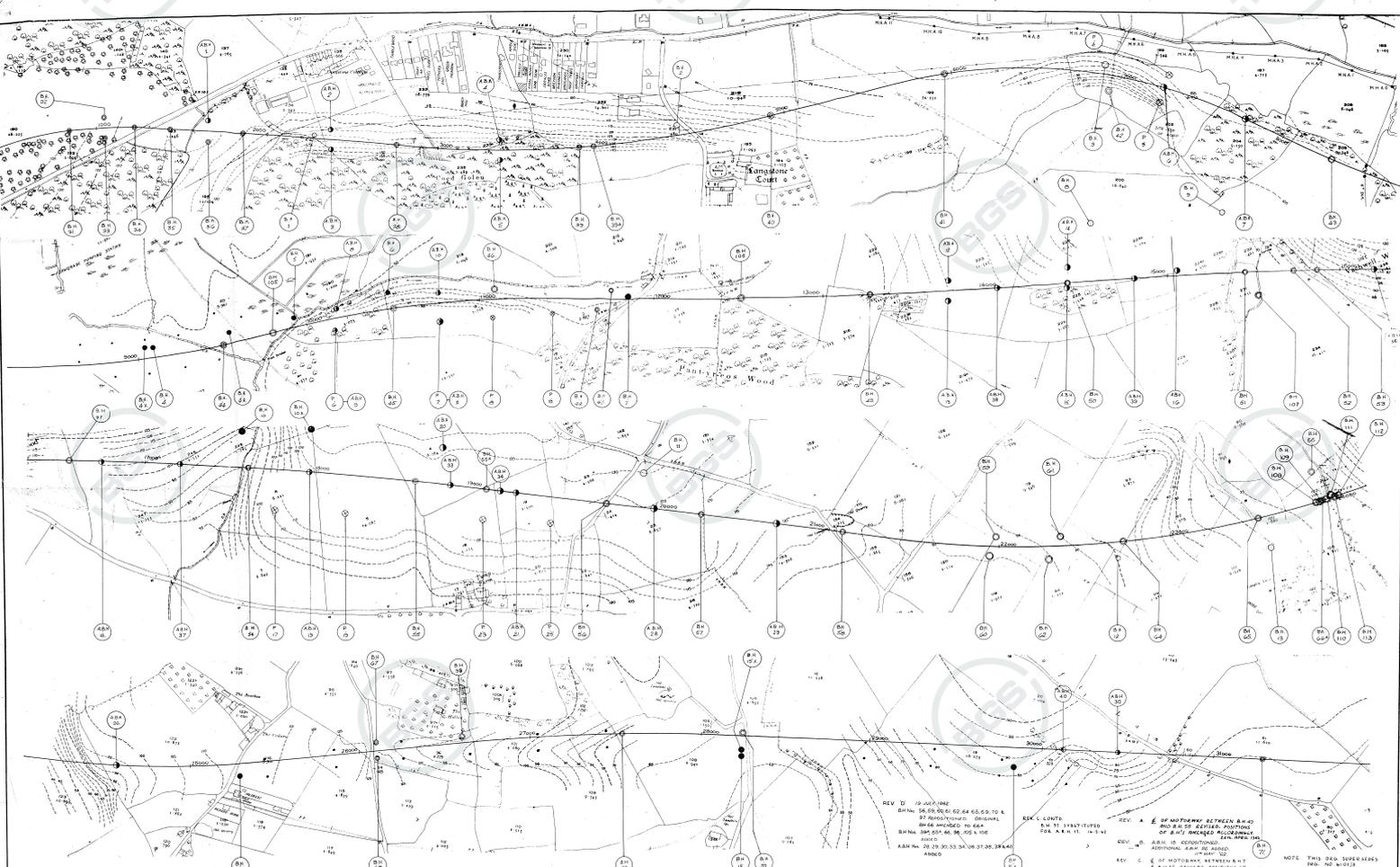

LONDON — SOUTH WALES MOTORWAY CRICK — EAST OF CHRISTCHURCH SPECIAL ROAD	SECOND SOIL SURVEY - BOREHOLE AND PROBE POSITIONS SHEET 1	G. MAUNSELL & PARTNERS, CONSULTING ENGINEERS WESTMINSTER, S.W.1 SCALE 1/2500 DATE 19 APR 1967 DRG. No. 601/5 <sup>c</sup>
--	---	---

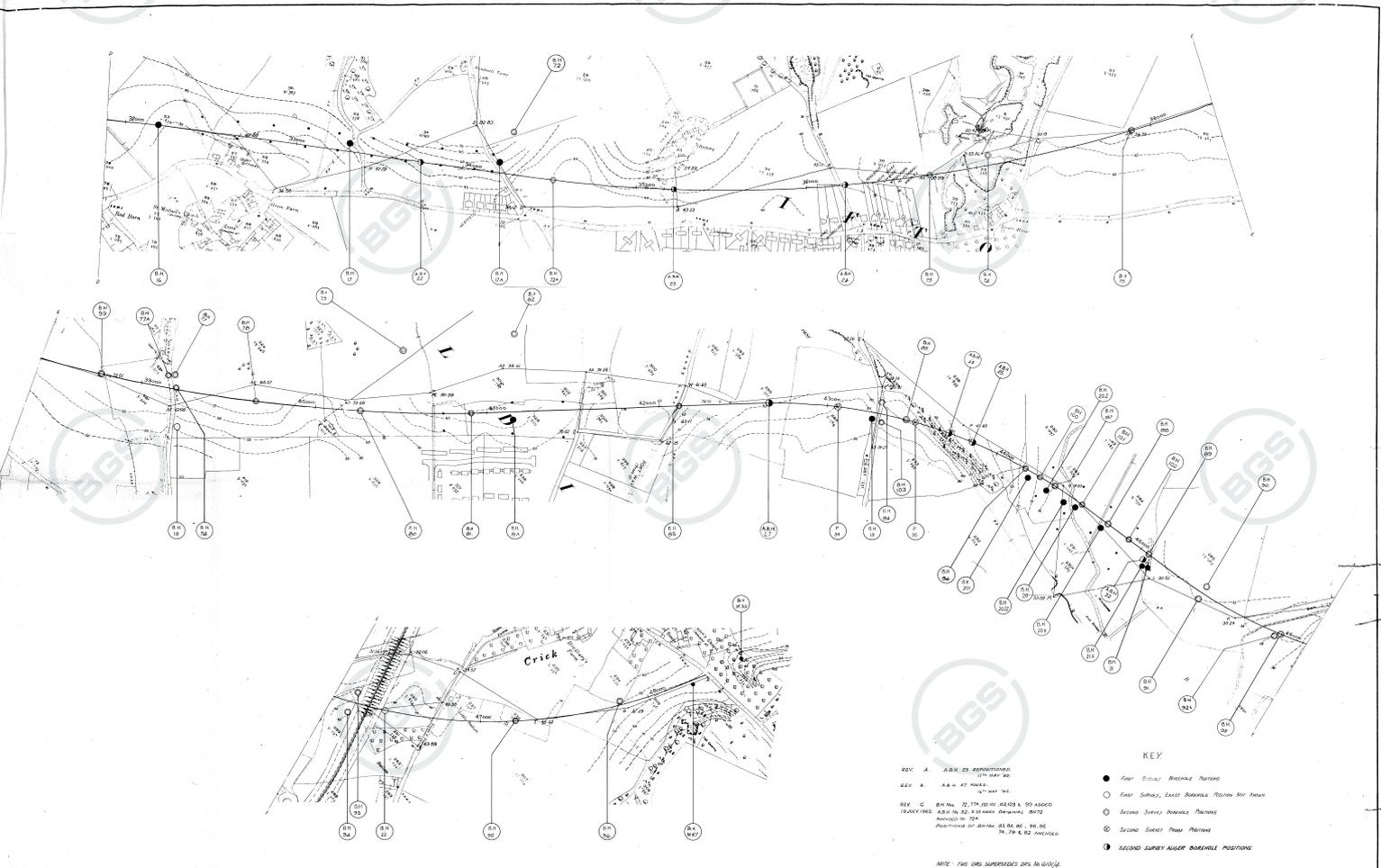

LONDON — SOUTH WALES MOTORWAY  
CRICK — EAST OF CHRISTCHURCH SPECIAL ROAD

SECOND SOIL SURVEY — BOREHOLE AND PROBE POSITIONS SHEET 2

G. MAUNSELL & PARTNERS,  
CONSULTING ENGINEERS  
WESTMINSTER, S.W.1.

SCALE 1/2500 DATE/MAY/04  
DRG. No. 610/6°

ST48NW/SZ

<b>Methods</b> Machine dug to 1.70m by Fiat/Hitachi 130. No support used. Looped on excavated material below 1.20m.		<b>Dates</b> 05/04/90		<b>Job No.</b> 7625	<b>Trial Pit No.</b> 7412 <b>Sheet</b> 1 of 2	
		<b>Coordinates</b> 342454 E 187753 N		<b>Site</b> SECOND SEVERN CROSSING Main Onshore Ground Investigation		
		<b>Ground Level</b> 11.77 mOD		<b>Client</b> Department of Transport		
Sample/Test		Level mOD	Depth m (Thick)	Description	Legend	
Depth m	Sample/Test					
0.00 - 0.10	D 1	11.67	0.10	a. TOPSOIL	[Cross-hatched pattern]	
0.10 - 1.40	B 2		(1.30)	b. Firm to stiff red brown very silty CLAY with many cobbles and occasional boulders of sandstone and conglomerate. (FILL)		
			10.37	1.40 (0.30)		c. Grey angular limestone BOULDERS in a little matrix of firm red brown sandy clay. (FILL)
		10.07	1.70			
<b>Remarks</b>  Insitu Tests: None Groundwater: Not encountered Variability of Faces: See sheet 2 Stability of Faces: Stable Weather: Fine See key sheet for symbols and abbreviations				<b>Plan (Not to scale)</b> 		
				Scale 1:50 Logged by PA		



ST48NW/52

		<b>Trial Pit No.</b> 7412	
<b>Methods</b> Machine dug to 1.70m by Fiat/Hitachi 130. No support used. Logged on excavated material below 1.20m.	<b>Dates</b> 05/04/90	<b>Job No.</b> 7625	<b>Sheet</b> 2 of 2
	<b>Coordinates</b> 342454 E 187753 N		<b>Site</b> SECOND SEVERN CROSSING Main Onshore Ground Investigation
	<b>Ground Level</b> 11.77 mOD	<b>Client</b> Department of Transport	

**Sketch of Faces**

NOT TO SCALE

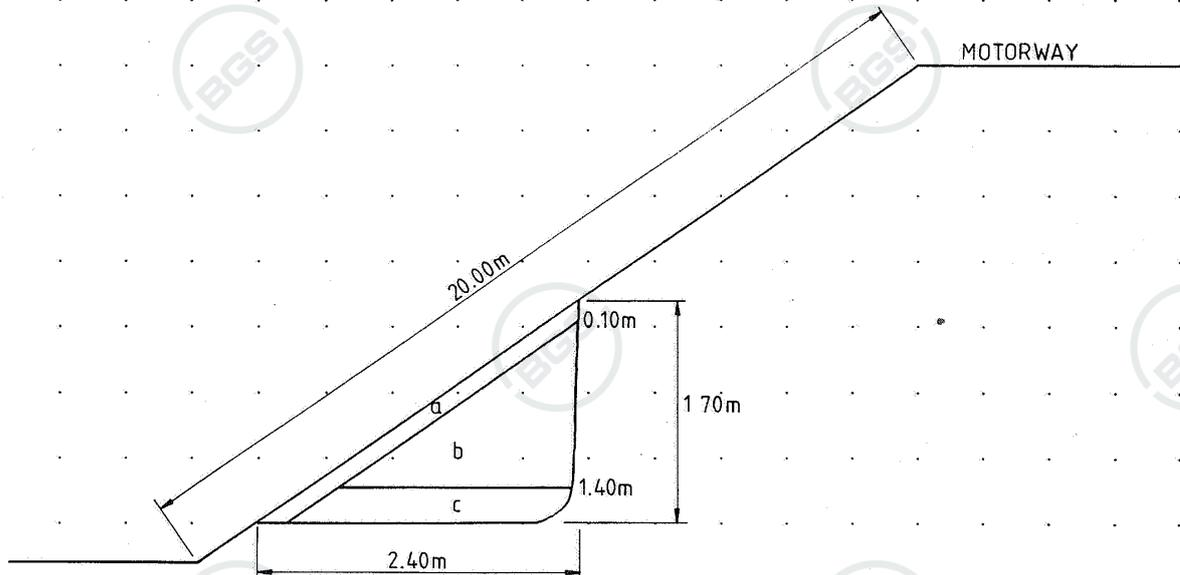

**Remarks**

See key sheet for symbols and abbreviations

090890/1635

Logged by  
PA

**BOREHOLE LOG**

BOREHOLE No 62

GROUND LEVEL : 85.6

TYPE of BORING: Power Auger.

DATE STARTED : 14.7.62.

DIA of BORING: 6"

DESCRIPTION	THICKNESS	DEPTH	LEGEND	SAMPLE No	No of BLOWS OR LOAD	LABORATORY TESTS	TOOLS USED
Firm red-brown CLAY and Gravel.	2' 6"	0' 0" to 2' 6"		1, 2	10 tons.	P.A.	Power Auger.
Firm to stiff red-brown CLAY.	12' 9" +	2' 6" to 15' 3"		3, 4, 5	5 tons.	P.A.	
LIMESTONE.		15' 3" to 16' 0"					

REMARKS:

<p><b>KEY TO LABORATORY TESTS</b></p> <p>W = MOISTURE CONTENT ; S = SIEVE ANALYSIS ; H = FULL MECH - ANICAL ANALYSIS ; A = PLASTICITY INDEX ; P = DRY DENSITY / MOISTURE RELATION ; T<sub>d</sub> = DRAINED TRIAXIAL ; T<sub>u</sub> = UNDRAINED TRIAXIAL ; R<sub>d</sub> = REMOULDED DRAINED TRIAXIAL ; R<sub>u</sub> = REMOULDED UNDRAINED TRIAXIAL ; K = C.B.R. (UNSOAKED) ; K<sub>s</sub> = C.B.R. (SOAKED) ; C = CONSOLIDATION ; U = UNCONFINED COMPRESSION TEST ; B = SHEAR BOX</p>	<p>LONDON - SOUTH WALES MOTORWAY COLDRA - CRICK.</p>
---	--

<p><b>KEY TO SAMPLES</b></p> <p> CORE BORING % RECOVERY</p>	<p> UNDISTURBED SAMPLE</p> <p> S.P.T. No of BLOWS</p>	<p> DISTURBED SAMPLE</p> <p> WATER LEVEL</p>	<p>FOUNDATION ENGINEERING LIMITED ; 111, WESTMINSTER BRIDGE ROAD, LONDON, S.E.1.</p>
---	---	--	--

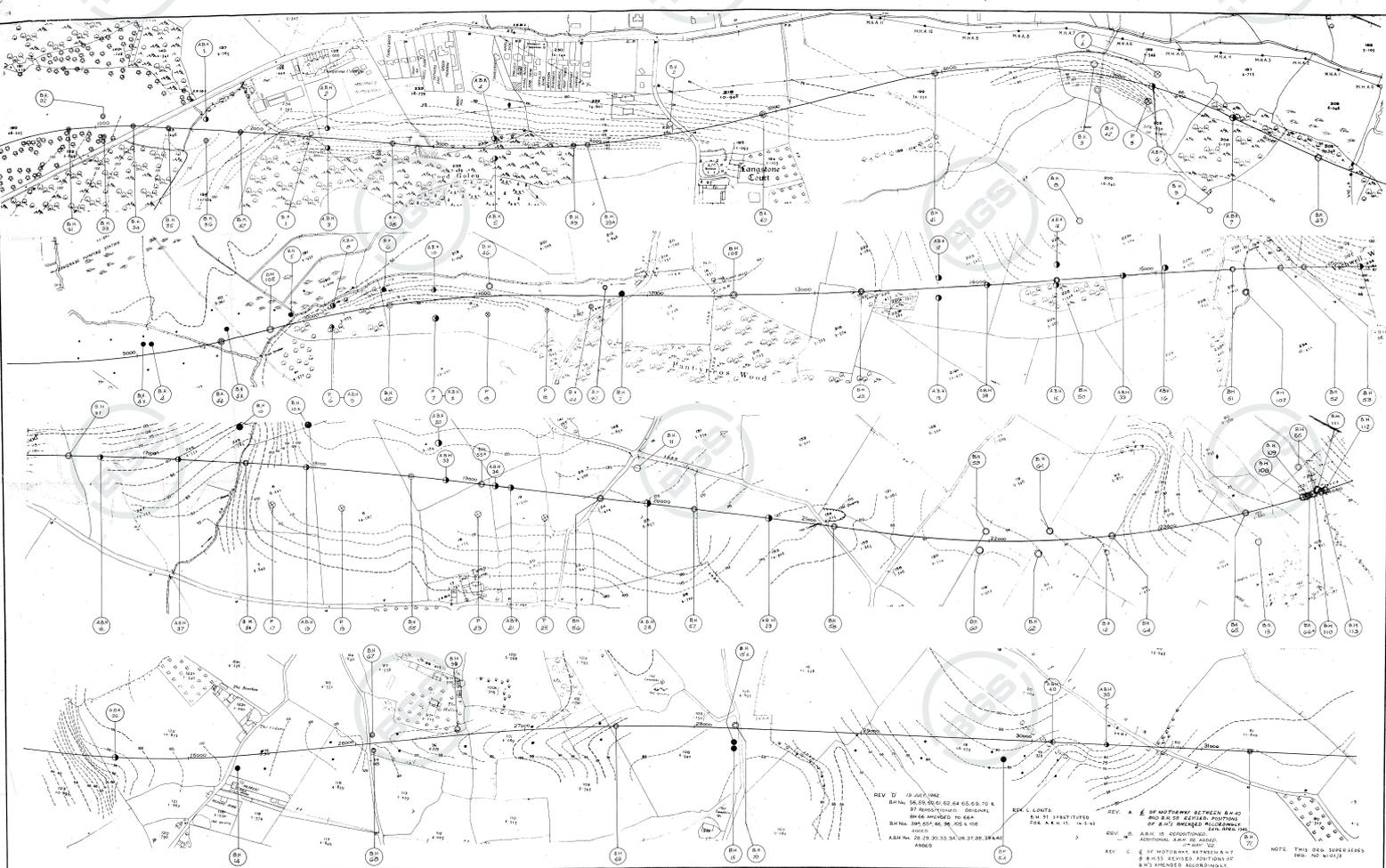

<p>LONDON — SOUTH WALES MOTORWAY CRICK — EAST OF CHRISTCHURCH SPECIAL ROAD</p>	<p>SECOND SOIL SURVEY - BOREHOLE AND PROBE POSITIONS SHEET 1</p>	<p>G. MAUNSELL &amp; PARTNERS, CONSULTING ENGINEERS WESTMINSTER, S.W.1</p> <p>SCALE 1:2500 DATE 15 APR 2002 DRG. No. 601/5<sup>c</sup></p>
--	--	--

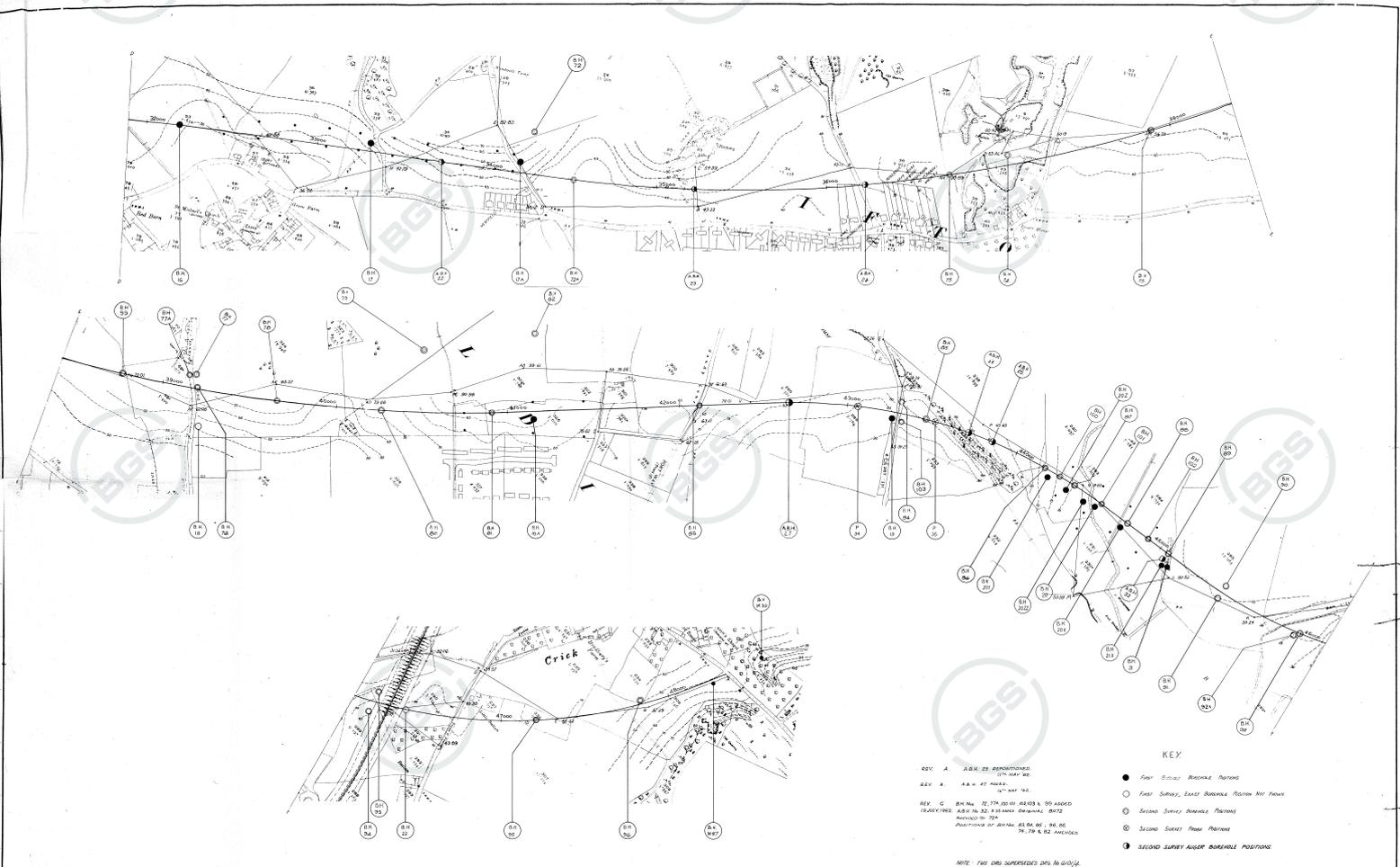

LONDON - SOUTH WALES MOTORWAY CRICK - EAST OF CHRISTCHURCH SPECIAL ROAD	SECOND SOIL SURVEY - BOREHOLE AND PROBE POSITIONS SHEET 2	G. MAUNSELL & PARTNERS, CONSULTING ENGINEERS WESTMINSTER, S.W.1. SCALE 1/2500 DATE: 14/11/04 DRG. No. 610/16 <sup>o</sup>
--	---	---

**BOREHOLE LOG**

BOREHOLE N° 66.

GROUND LEVEL : 34.1

TYPE OF BORING: Power Auger.

DATE STARTED : 9.7.62

DIA OF BORING: 6"

DESCRIPTION	THICKNESS	DEPTH	LEGEND	SAMPLE N°	N° OF BLOWS OR LOAD.	LABORATORY TESTS	TOOLS USED.
TOPSOIL.	3' 0"	0'd'					
Soft grey silty CLAY with stones	3' 6"	3' 0"	X	1	5 tons.	Tu	Power Auger.
		3' 6"	X	2			
Firm red-brown silty sandy CLAY with soft layers and stones	18' 6"	6' 6"	X	3	12 blows/ft.		
		6' 6"	X	4			
		6' 6"	X				
		6' 6"	X				
		6' 6"	X				
		6' 6"	X				
		6' 6"	X				
		6' 6"	X				
		6' 6"	X				
		6' 6"	X				
Firm to stiff red-brown sandy silty marly CLAY.	5' 0" +	25' 0"	X	5	50 blows/ft.		
		25' 0"	X	6			
		25' 0"	X				
		25' 0"	X				
		25' 0"	X				
		25' 0"	X				
		25' 0"	X				
		25' 0"	X				
		25' 0"	X				
		25' 0"	X				
		30' 0"	X	7	45 blows/ft.		
		30' 0"	X	8			

REMARKS:

<p><b>KEY TO LABORATORY TESTS</b></p> <p>W = MOISTURE CONTENT; S = SIEVE ANALYSIS; H = FULL MECH - ANICAL ANALYSIS; A = PLASTICITY INDEX; P = DRY DENSITY/ MOISTURE RELATION; Td = DRAINED TRIAXIAL; Tu = UNDRAINDED TRIAXIAL; Rd = REMOULDED DRAINDED TRIAXIAL; Ru = REMOULDED UNDRAINDED TRIAXIAL; K = C.B.R. (UNSOAKED); Ks = C.B.R. (SOAKED); C = CONSOLIDATION; U = UNDRAINDED COMPRESSION TEST; B = SHEAR BOX.</p>		<p>LONDON - SOUTH WALES MOTORWAY COLDRA - CRICK.</p>
--	--	--

<p>KEY TO SAMPLES.</p> <p>□ CORE BORING % RECOVERY</p>	<p>▬ UNDISTURBED SAMPLE</p> <p>+ S.P.T. N° OF BLOWS</p>	<p>● DISTURBED SAMPLE</p> <p>≡ WATER LEVEL</p>	<p>FOUNDATION ENGINEERING LIMITED; 111, WESTMINSTER BRIDGE ROAD, LONDON S.E.1.</p>
--	---	--	--

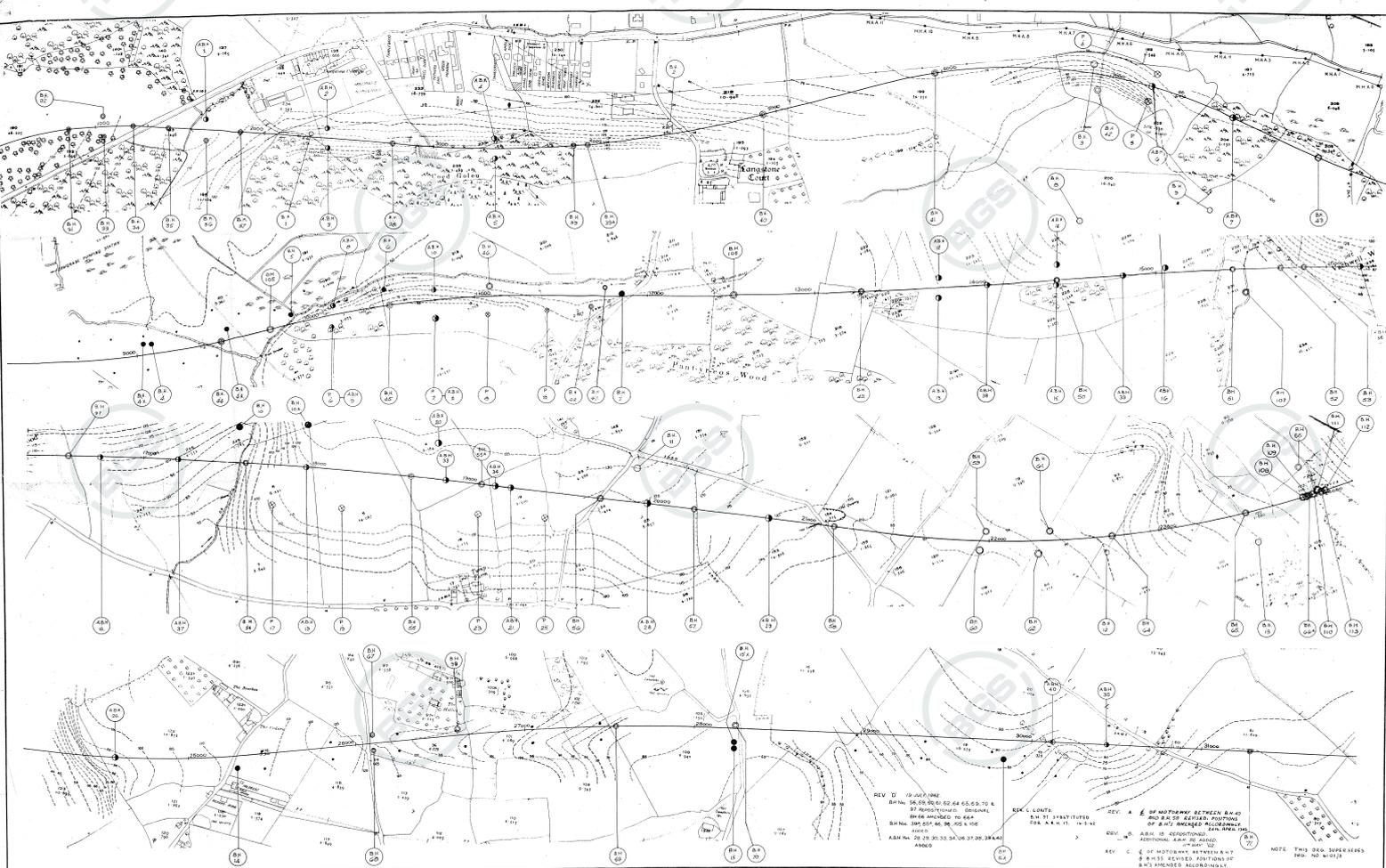

LONDON — SOUTH WALES MOTORWAY CRICK — EAST OF CHRISTCHURCH SPECIAL ROAD	SECOND SOIL SURVEY - BOREHOLE AND PROBE POSITIONS SHEET 1	G. MAUNSELL & PARTNERS, CONSULTING ENGINEERS WESTMINSTER, S.W.1 SCALE 1:2500 DATE 15 APR 06 DRG. No. 601/5 <sup>c</sup>
--	---	---

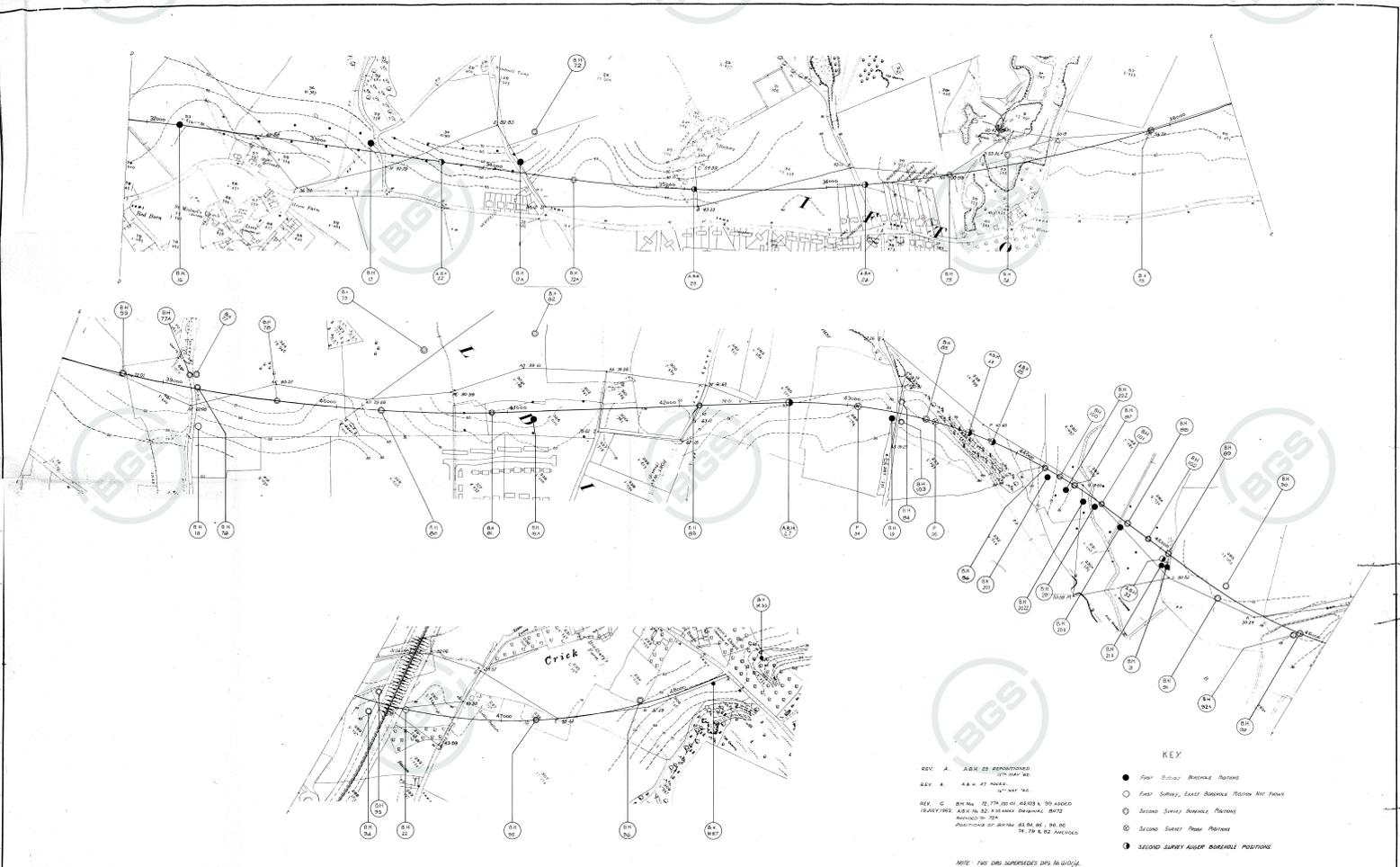

LONDON — SOUTH WALES MOTORWAY CRICK — EAST OF CHRISTCHURCH SPECIAL ROAD	SECOND SOIL SURVEY — BOREHOLE AND PROBE POSITIONS — SHEET 2	G. MAUNSELL & PARTNERS, CONSULTING ENGINEERS WESTMINSTER, S.W.1. SCALE 1/2500 DATE: 14/11/02 DRG. No. 610/69
--	---	---





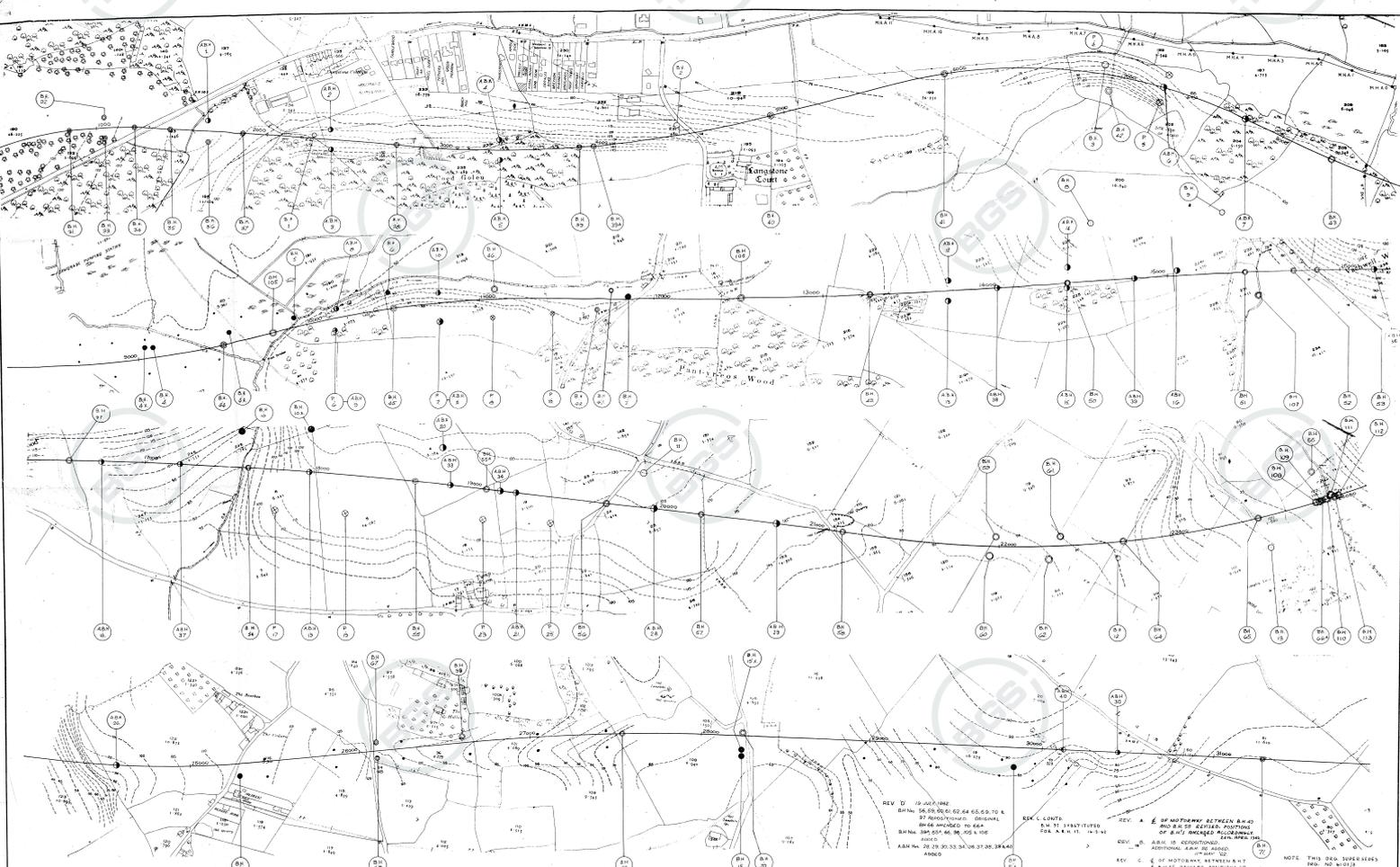

LONDON — SOUTH WALES MOTORWAY CRICK — EAST OF CHRISTCHURCH SPECIAL ROAD	SECOND SOIL SURVEY - BOREHOLE AND PROBE POSITIONS SHEET 1	G. MAUNSELL & PARTNERS, CONSULTING ENGINEERS WESTMINSTER, S.W.1 SCALE 1:2500 DATE 15 APR 2006 DRG. No. 601/5
--	---	--

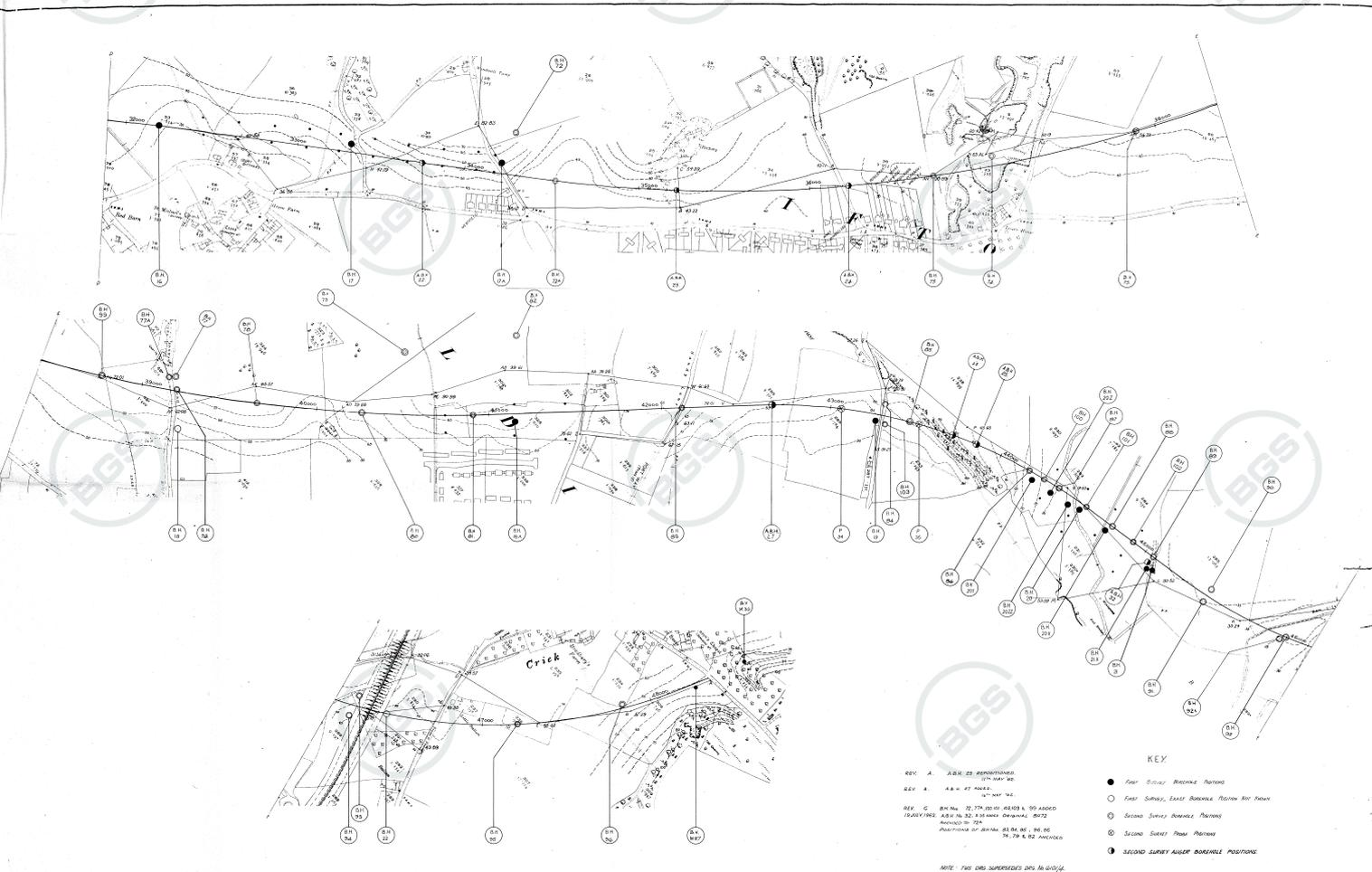

LONDON - SOUTH WALES MOTORWAY CRICK - EAST OF CHRISTCHURCH SPECIAL ROAD	SECOND SOIL SURVEY - BOREHOLE AND PROBE POSITIONS SHEET 2	G. MAUNSELL & PARTNERS, CONSULTING ENGINEERS WESTMINSTER, S.W.1. SCALE 1/2500 DATE: 14/10/02 DRG. No. 610/69
--	---	---

**BOREHOLE LOG /;**

BOREHOLE N° 113

GROUND LEVEL : 33

TYPE of BORING: Shell and Auger.

DATE STARTED : 17.10.62

DIA of BORING: 6"

DESCRIPTION	THICKNESS	DEPTH	LEGEND	SAMPLE N°	N° of BLOWS OR LOAD.	LABORATORY TESTS.	TOOLS Used.
TOPSOIL.	1'0"	0'0" 1'0"					
Loose sandy CLAY.	2'9"	3'9"		• 1 • 2			
Firm red CLAY with traces of sand.	5'0"	9'0"		3	18 blows/ft.	T <sub>u</sub>	
Firm red CLAY with pieces of weathered limestone.	1'6" +	10'6"		• 4.			

REMARKS:

**KEY TO LABORATORY TESTS**  
 W = MOISTURE CONTENT; S = SIEVE ANALYSIS; H = FULL MECH - ANICAL ANALYSIS; A = PLASTICITY INDEX; P = DRY DENSITY / MOISTURE RELATION; T<sub>d</sub> = DRAINED TRIAXIAL; T<sub>u</sub> = UNDRAINED TRIAXIAL; R<sub>d</sub> = REMOULDED DRAINED TRIAXIAL; R<sub>u</sub> = REMOULDED UNDRAINED TRIAXIAL; K = C.B.R. (UNSOAKED); K<sub>s</sub> = C.B.R. (SOAKED); C = CONSOLIDATION; U = UNCONFINED COMPRESSION TEST; B = SHEAR BOX

LONDON - SOUTH WALES MOTORWAY  
COLDRA - CRICK.

**KEY TO SAMPLES.**  
 □ CORE BORING / % RECOVERY  
 + S.P.T. N° OF BLOWS  
 ▬ UNDISTURBED SAMPLE  
 ● DISTURBED SAMPLE  
 ≍ WATER LEVEL

FOUNDATION ENGINEERING LIMITED;  
111, WESTMINSTER BRIDGE ROAD,  
LONDON S.E. 1.

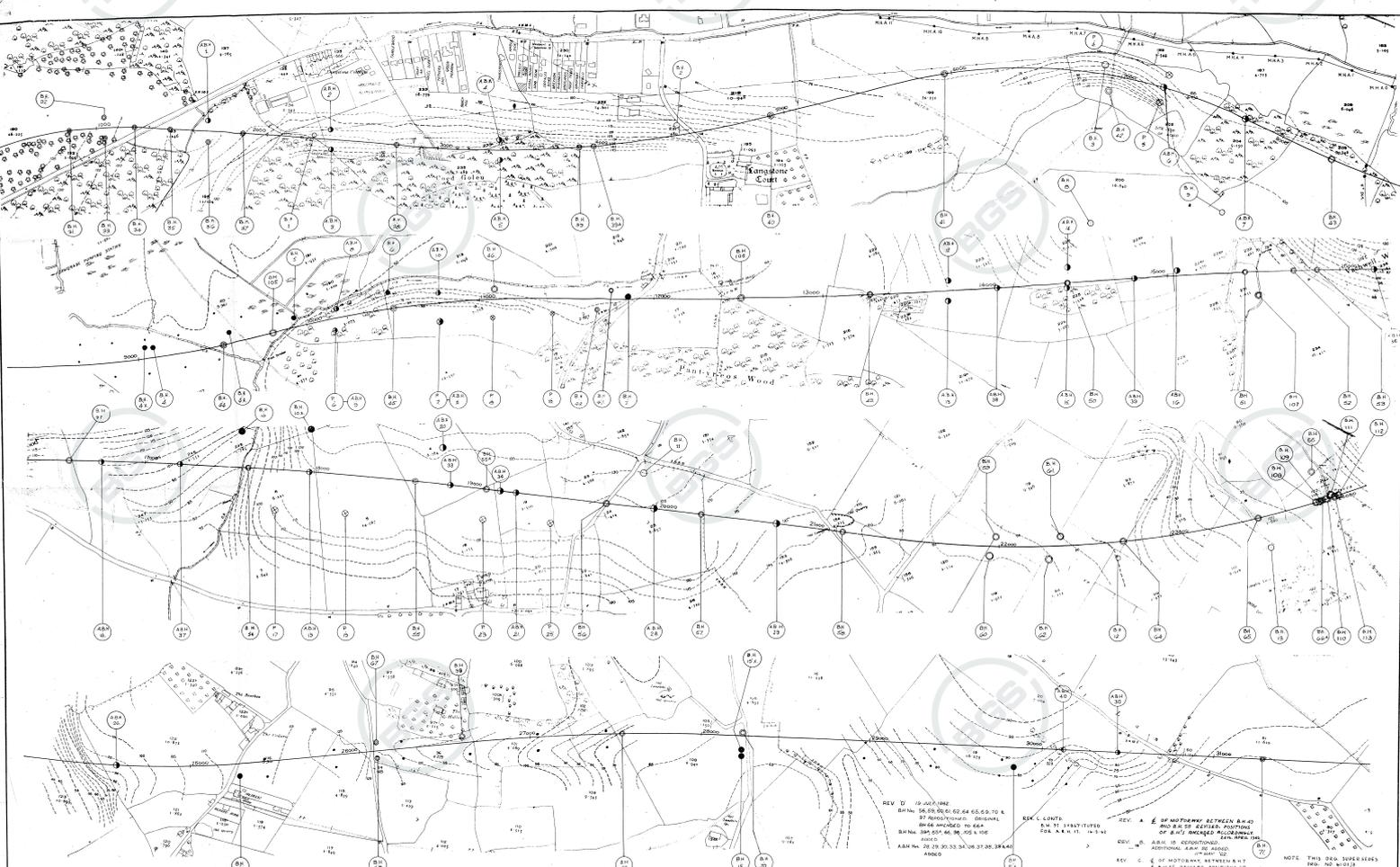

LONDON — SOUTH WALES MOTORWAY CRICK — EAST OF CHRISTCHURCH SPECIAL ROAD	SECOND SOIL SURVEY - BOREHOLE AND PROBE POSITIONS SHEET 1	G. MAUNSELL & PARTNERS, CONSULTING ENGINEERS WESTMINSTER, S.W.1 SCALE 1:2500 DATE 15 APR 2002 DRG. No. 601/5 <sup>c</sup>
--	---	---

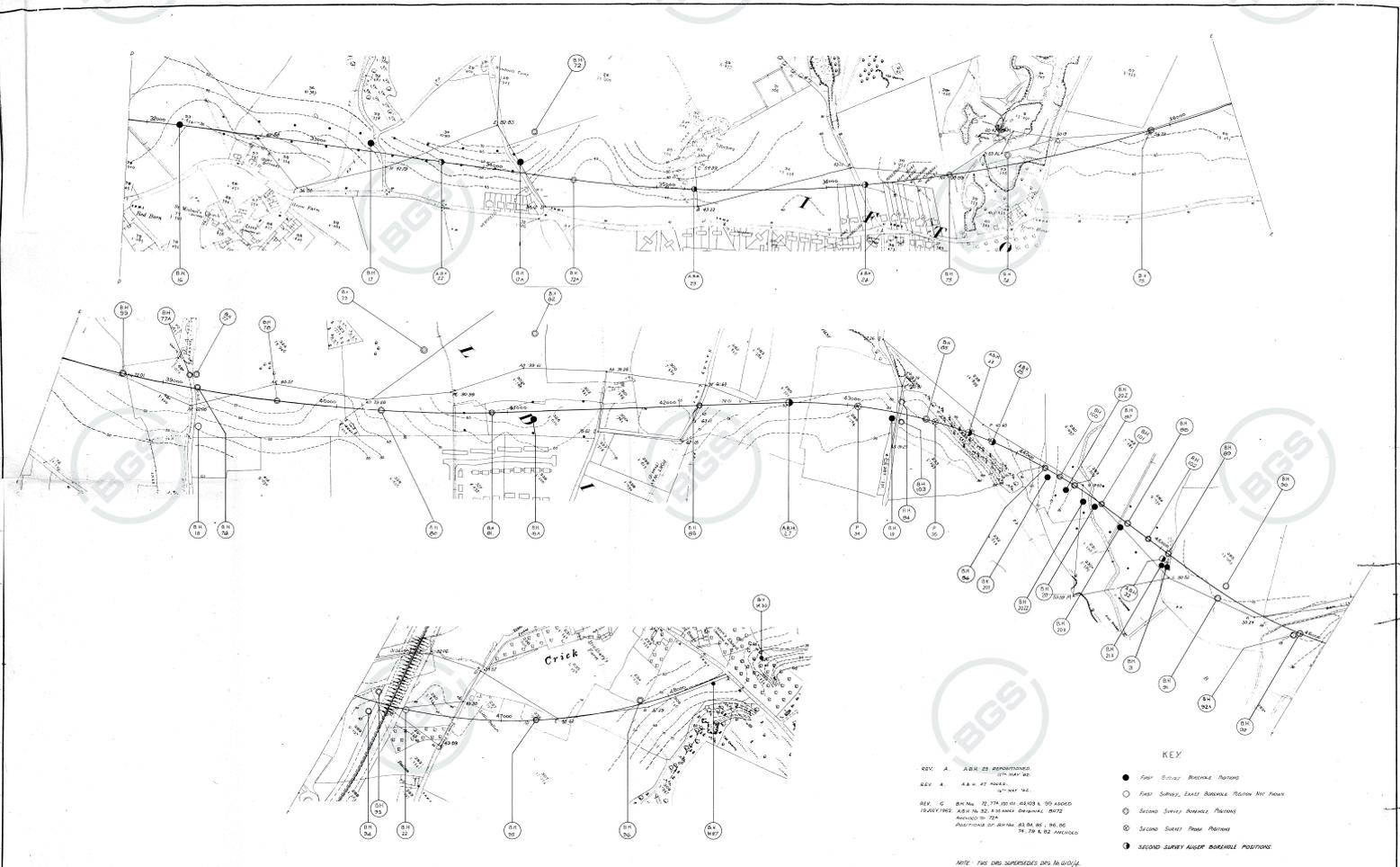

LONDON - SOUTH WALES MOTORWAY CRICK - EAST OF CHRISTCHURCH SPECIAL ROAD	SECOND SOIL SURVEY - BOREHOLE AND PROBE POSITIONS SHEET 2	G. MAUNSELL & PARTNERS, CONSULTING ENGINEERS WESTMINSTER, S.W.1. SCALE 1/2500 DATE: 14/01/02 DRG. No. 610/69
--	---	--

**BOREHOLE LOG**

BOREHOLE N° 112

GROUND LEVEL : 33

TYPE OF BORING: Shell and Auger.

DATE STARTED : 16.10.62.

DIA OF BORING: 6"

DESCRIPTION	THICKNESS	DEPTH	LEGEND	SAMPLE N°	N° OF BLOWS OR LOAD.	LABORATORY TESTS	TOOLS USED.
TOPSOIL.	1'0"	0'0" 1'0"		1	22	T <sub>0</sub>	
Firm red-brown CLAY.	3'0"	4'0"		2	blows/ft		
Mottled sandy CLAY.	4'6"	8'6"		3			
Red CLAY and weathered limestone.	2'6" +	11'0"		4 5	29 blows/ft	T <sub>0</sub>	

REMARKS: Attempted U4 at 5'0".

**KEY TO LABORATORY TESTS**

W = MOISTURE CONTENT; S = SIEVE ANALYSIS; H = FULL MECH-ANICAL ANALYSIS; A = PLASTICITY INDEX; P = DRY DENSITY/MOISTURE RELATION; T<sub>0</sub> = DRAINER TRIAXIAL; T<sub>u</sub> = UNDRAINER TRIAXIAL; R<sub>d</sub> = REMOULDED DRAINER TRIAXIAL; R<sub>u</sub> = REMOULDED UNDRAINER TRIAXIAL; K = C.B.R. (UNSOAKED); K<sub>s</sub> = C.B.R. (SOAKED); C = CONSOLIDATION; U = UNCONFINED COMPRESSION TEST; B = SHEAR BOX

LONDON-SOUTH WALES MOTORWAY  
COLDRA - CRICK.

KEY TO SAMPLES.	UNDISTURBED SAMPLE	DISTURBED SAMPLE
CORE BORING % RECOVERY	+ S.P.T. No. OF BLOWS	WATER

FOUNDATION ENGINEERING LIMITED;  
111, WESTMINSTER BRIDGE ROAD,  
LONDON, S.E.1.

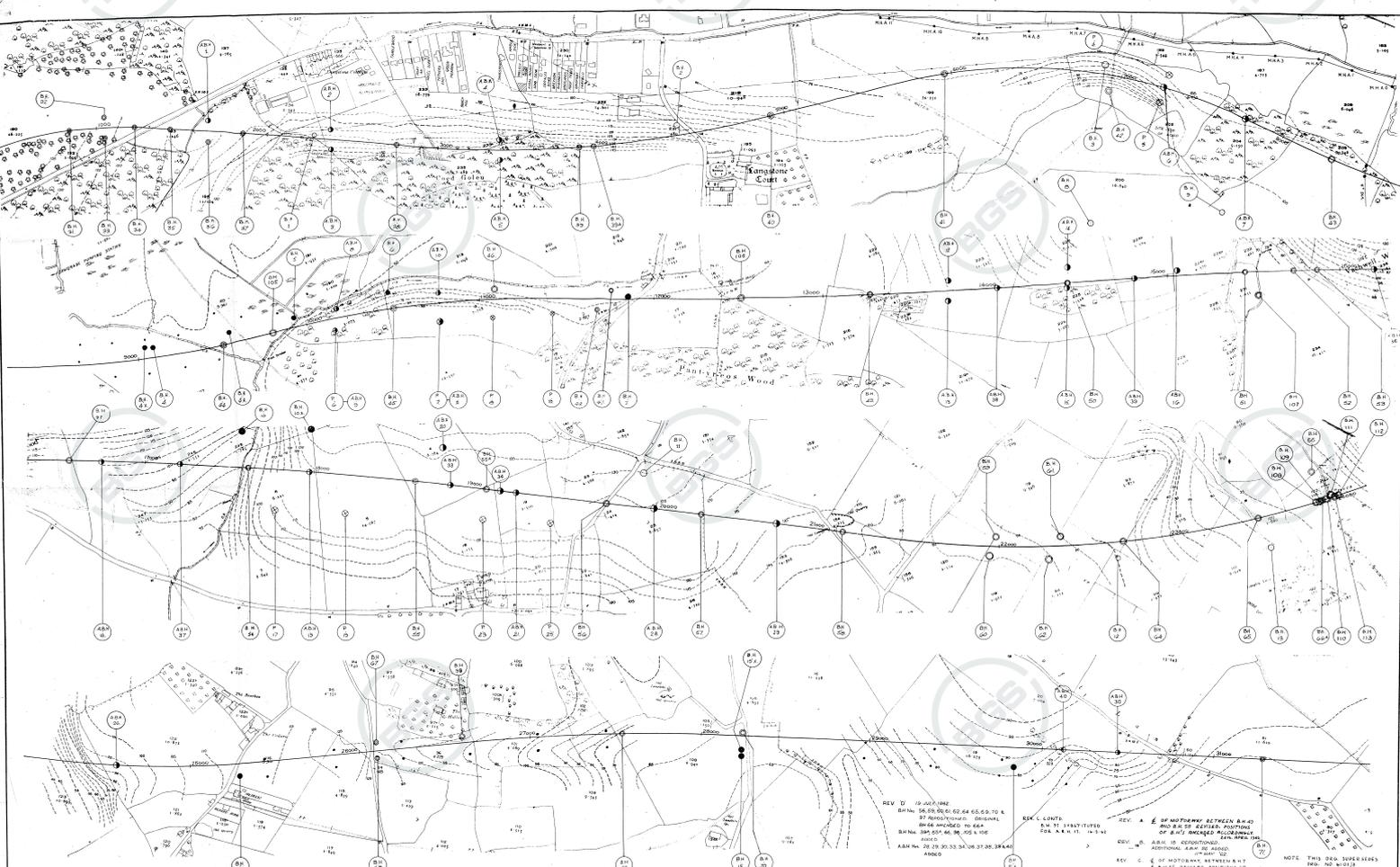

LONDON — SOUTH WALES MOTORWAY CRICK — EAST OF CHRISTCHURCH SPECIAL ROAD	SECOND SOIL SURVEY - BOREHOLE AND PROBE POSITIONS SHEET 1	G. MAUNSELL & PARTNERS, CONSULTING ENGINEERS WESTMINSTER, S.W.1 SCALE 1/2500 DATE 19 4/92 262 DRG. No. 601/5 <sup>c</sup>
--	---	---





## C. Site Walkover Survey Photographs

**Photo C.1: View looking to the east towards the site entrance on St Bride's Road**



**Photo C.2: View looking towards the northern section of the site**



**Photo C.3: View of the south-western edge of site looking towards the west**



**Photo C.4: View of the north-eastern edge of site showing the animal water trough in the site centre and a steep sloped section**



**Photo C.5: Close-up view of animal water trough and blue alkathene pipe water supply in the centre of the site**



**Photo C.6: Blue alkathene pipe near the gate along St Bride's Road**



**Photo C.7: View from the western edge of site looking towards the north-east**



**Photo C.8: View from the western edge of site looking towards the north**



**Photo C.9: View showing hedges from the centre of the site looking towards the south-east**



**Photo C.10: View of bricks and roots located along the northern edge of site**



**Photo C.11: View of the northern edge of site looking towards the west**



**Photo C.12: View of the northern edge of site looking towards the east including view of silage for cattle feeding**



**Photo C.13: View towards site entrance at the eastern edge of site**



**Photo C.14: View from the site entrance looking westwards**



**Photo C.15: View of metal caravan at the eastern edge of site**



**Photo C.16: Wooden boards beside metal caravan at eastern edge of the site**







This page is intentionally left blank

A large teal graphic element on the left side of the page, consisting of a triangle at the top and a vertical rectangle below it, with a diagonal cutout in the upper right corner.

# **Proposed Gypsy and Traveller Site - Bradbury Farm, Crick**

Land Contamination Assessment

February 2024

This page left intentionally blank for pagination.

Mott MacDonald  
2 Callaghan Square  
Cardiff CF10 5BT  
United Kingdom

T +44 (0)29 2046 7800  
mottmac.com

# **Proposed Gypsy and Traveller Site - Bradbury Farm, Crick**

Land Contamination Assessment

February 2024

# Issue and Revision Record

Revision	Date	Originator	Checker	Approver	Description
P01	February 2024	A Packman	N Cummins	C Williams	First Issue

**Document reference:** 100115516 | LQ002 | P01 |

**Information class:** Standard

---

This document is issued for the party which commissioned it and for specific purposes connected with the above-captioned project only. It should not be relied upon by any other party or used for any other purpose.

We accept no responsibility for the consequences of this document being relied upon by any other party, or being used for any other purpose, or containing any error or omission which is due to an error or omission in data supplied to us by other parties.

This document contains confidential information and proprietary intellectual property. It should not be shown to other parties without consent from us and from the party which commissioned it.

---

# Contents

<b>1</b>	<b>Introduction</b>	<b>1</b>
1.1	Details of Scheme	1
1.2	Report scope	1
1.3	Report Objectives	1
1.4	Methodology	1
1.5	Limitations	2
<b>2</b>	<b>Sources of information</b>	<b>3</b>
2.1	Historical Ordnance Survey Maps	3
2.2	British Geological Survey (BGS)	3
2.3	Previous Desk Studies and Ground Investigations	3
2.4	Mining quarrying and mineral deposits	3
2.5	Land mass movement	3
2.6	Hydrology and hydrogeology	3
2.7	Unexploded ordnance	4
2.8	Radon	4
<b>3</b>	<b>Site Description</b>	<b>5</b>
3.1	General	5
3.2	Topography	6
3.3	Geomorphology	6
3.4	Historic development and current land use	6
3.5	Unexploded ordnance	8
3.6	Other information	8
3.7	Site reconnaissance	10
<b>4</b>	<b>Ground Conditions</b>	<b>12</b>
4.1	Topsoil	12
4.2	Artificial ground	12
4.3	Superficial deposits	12
4.4	Bedrock geology	12
4.5	Land mass movement	12
4.6	Mining and quarrying	12
4.7	BGS Ground Stability Hazards	13
4.8	Hydrology and flooding	13
4.9	Hydrogeology	13
4.10	Historical Ground Investigations	14
4.11	Ground Gas Generation Potential	15

5	Preliminary Ground Model	16
5.2	Groundwater	16
5.3	Obstructions	16
6	Preliminary Contamination Risk Assessment	17
6.1	Preliminary Conceptual Model Methodology	17
6.2	Preliminary Risk Assessment Methodology	17
6.3	Preliminary Conceptual Site Model	19
7	Conclusions	22
7.1	Ground Conditions	22
7.2	Recommendations	23
A.	Groundsure Environmental and Geo Insight Report	25
B.	British Geological Society Historic Borehole Records	26
C.	Site Walkover Survey Photographs	27



# 1 Introduction

## 1.1 Details of Scheme

Monmouthshire County Council (MCC) has a legal and moral duty to ensure everyone has access to good quality homes. MCC recognises that safe, culturally appropriate accommodation is necessary for individuals to flourish in other parts of their lives. In accordance with the Housing (Wales) Act, 2014, MCC has identified a need for additional sites to house the Gypsy and Traveller families already living in Monmouthshire. Three Council-owned sites in Monmouthshire have been identified as potentially suitable to meet the current needs for the Gypsy and Traveller community.

Mott MacDonald has been appointed by MCC to provide a land contamination report as part of MCC's Gypsy and Traveller Accommodation Assessment (GTAA) identification study for Bradbury Farm, Crick, Monmouthshire (hereafter referred to as "the proposed Gypsy & Traveller site" or simply "the site"), one of the three identified sites for potential development. The proposed Gypsy & Traveller site is understood to comprise the construction of up to six pitches that will include parking and a collective utility block. The site is accessed from Crick Road.

The site is located in Monmouthshire, south-east Wales, some 370m to the south of the village of Crick and some 1.8km to the north-east of the town of Caldicot. The site is roughly rectangular in shape and centred at National Grid Reference (NGR) ST 48987 89858. For the purpose of this report a reporting buffer of 500m has been identified around the site to identify features within the surrounding area which may impact upon the site.

## 1.2 Report scope

The scope of this desk study is to:

- Review freely available information, and client supplied data, for an understanding of the proposed development
- Review and summarise site-specific information
- Develop a preliminary ground model for the site
- Identify ground related risks which may impact future ground investigations (GI)
- Develop a conceptual site model and identify potential contaminant linkages present at the site
- Undertake a Preliminary Contaminated Land Risk Assessment (CLRA), and
- Provide recommendations (if necessary) for further assessments, including project specific investigations.

## 1.3 Report Objectives

The key objective of this report is to provide a high-level assessment of the likely ground conditions underlying the site and their potential geo-environmental impact upon the scheme and make recommendations on how these risks can be managed.

## 1.4 Methodology

This desk-based review and report have been completed in accordance with the with the following guidance documents and standards:

- Development of Land Affected by Contamination: A Guide for Developers. Welsh Government Ver 4, September 2023
- BS10175:2011+A2:2017, Investigation of Potentially Contaminated Sites, Code of Practice, December 2017
- CIRIA C552, Contaminated Land Risk Assessment - A Guide to Good Practice, January 2001.

## 1.5 Limitations

This report has been prepared for the titled project or named part thereof and should not be relied upon or used for any other project without an independent check being carried out for the suitability and written authority from Mott MacDonald Ltd being obtained.

Mott MacDonald Ltd accepts no responsibility or liability for the consequences of this document being used for the purpose other than the proposed for which it was commissioned. Any person using or relying on the document for such other purposes agrees – with use or reliance to be taken as confirmation, that this indemnifies Mott MacDonald Ltd for all loss or damage resulting from therein. Mott MacDonald Ltd accepts no responsibility or liability for this document to any party other than the person by whom it was commissioned.

To the extent that this document is based on information supplied by other parties, Mott MacDonald Ltd accepts no liability for any loss or damage suffered by the Client stemming from any conclusions based on data supplied by parties other than Mott MacDonald Ltd and used by Mott MacDonald Ltd in preparing this report.

To the extent that this document is based on information obtained in previous or recent ground investigations, persons using or relying on it should recognise that such investigation can examine only a fraction of the subsurface conditions. In any ground investigation there remains the risk that pockets or 'hotspots' of contamination or other ground hazards may not be identified, because investigations are necessarily based on sample at localised points. Certain indicators or evidence of hazardous substance or conditions may have been outside the portion of the subsurface investigated or monitored, and thus may not have been identified or their full significance appreciated.

Mott MacDonald Ltd is not insured for, and therefore will not undertake surveys to identify any asbestos or provide guidance on the treatment of asbestos, or similarly for toxic mould. Should the presence of asbestos or toxic mould be suspected during the course of the study, Mott MacDonald Ltd would recommend the appointment of a specialist contractor to address the issue and would not provide advice on the risk or remedial measures.

This review considers the risks associated with the proposed use of the site only. This report should not be relied upon by any other third party.

## 2 Sources of information

### 2.1 Historical Ordnance Survey Maps

The following sources of information have been used as part of the historical map review process:

- Groundsure Environmental and Geo Insight Report (Appendix A)
- National Library of Scotland Side-by-Side Map Viewer<sup>1</sup>
- Google Earth Pro<sup>2</sup>

### 2.2 British Geological Survey (BGS)

The following sources of information have been used to determine the geological conditions underlying the site:

- British Geological Society GeoIndex Onshore<sup>3</sup>
- British Geological Survey Sheet 250 Chepstow (1:50,000) Bedrock and Drift<sup>4</sup>
- British Geological Survey National Grid Series Sheet ST48NE(1:10,560) Bedrock and Drift<sup>5</sup>
- BGS Lexicon of Named Rock Units<sup>6</sup>

### 2.3 Previous Desk Studies and Ground Investigations

Mott MacDonald are not aware of any previous desk studies or ground investigations having been carried out on the site previously. However historic ground investigation information from works carried out in the vicinity of the site was reviewed using the BGS GeoIndex<sup>3</sup> online viewer.

### 2.4 Mining quarrying and mineral deposits

The BGS GeoIndex<sup>3</sup> online map viewer and Coal Authority Interactive Online Map Viewer<sup>7</sup> were reviewed as part of this study and are discussed in Section 4.6.

### 2.5 Land mass movement

Land mass movement was reviewed as part of this study using the BGS GeoIndex<sup>3</sup> online map viewer.

### 2.6 Hydrology and hydrogeology

Long term flood risk for the site has been obtained from Natural Resource Wales (NRW) Flood Maps<sup>8</sup> for the scheme area. Flood risk is discussed in Section 4.8 of this report.

---

<sup>1</sup> [Side by side georeferenced maps viewer - Map images - National Library of Scotland \(nls.uk\)](#) – Accessed December 2023

<sup>2</sup> [Earth Versions – Google Earth](#) – accessed December 2023

<sup>3</sup> [GeoIndex \(onshore\) - British Geological Survey \(bgs.ac.uk\)](#) – Accessed December 2023

<sup>4</sup> British Geological Survey (2011). 1:63,360/1:50,000 geological map series, sheet number 250, solid and drift. Chepstow.

<sup>5</sup> British Geological Survey (1980). 1:10,560/1:10,000 geological map series. Sheet ST48NE. Solid and drift.

<sup>6</sup> British Geological Survey (2023). Lexicon of Named Rock Units (<https://www.bgs.ac.uk/Lexicon/>).

<sup>7</sup> [Interactive Map Viewer | Coal Authority \(bgs.ac.uk\)](#) – Accessed December 2023

<sup>8</sup> [Flood and Coastal Erosion Risk Maps \(naturalresources.wales\)](#) – Accessed December 2023

Hydrogeology has been reviewed using the BGS GeoIndex<sup>3</sup> online map viewer.

## 2.7 Unexploded ordnance

A preliminary UXO threat assessment for the site has been made using the Zetica UXO<sup>9</sup> online risk mapping.

## 2.8 Radon

UK Health Security Agency's (UKHSA) interactive radon map<sup>10</sup> and Groundsure Report were reviewed as part of this scheme to assess radon risk at the site and in the surrounding area.

---

<sup>9</sup> [Risk Maps | Zetica UXO](#) – Accessed December 2023

<sup>10</sup> [UKradon - UK maps of radon](#) – Accessed December 2023

## 3 Site Description

### 3.1 General

The site is a green space comprising open grassland centred at UK National Grid Reference ST 48986 89851. It is approximately 180m in length and 100m wide and is approximately rectangular in shape. The site has a perimeter length of 610m and an approximate area of 1.74 hectares.

The site is bounded by the M48 motorway to the north, beyond which is the village of Crick, to the east by open fields, a linear woodland running in a north-south orientation and a solar farm, to the south by open fields and to the west by Crick Road beyond which are open fields and a pair of residential properties. The location of the site both regionally and locally can be found in Figure 3.1 and Figure 3.2.

**Figure 3.1: Regional Site Location Plan**



Source: Mott MacDonald/ArcGIS, 2023

**Figure 3.2: Local Site Location Plan**



Source: Mott MacDonald/ArcGIS, 2023

The site itself comprises open grassland used for the grazing of sheep with overhead power lines running north to south through the approximate centre of the site.

### 3.2 Topography

The topography of the site has been assessed from Google Earth<sup>2</sup> and verified by a site visit on 12<sup>th</sup> January 2024. The site topography is relatively flat and level being located at between 12m and 14m Above Ordnance Datum (mAOD) with the lowest part of the site being in the south-west corner of the site, coincident with the access point off Crick Road.

### 3.3 Geomorphology

BGS 1:10,000 geological map Sheet ST48NE<sup>5</sup> does not indicate any geomorphological features on the site with the only feature recorded comprising a geological boundary within the superficial deposits showing 'Gravel Flat' in the west and 'Red Loam' in the east.

### 3.4 Historic development and current land use

A review of the historical development of the site has been undertaken using historical and current Ordnance Survey (OS) mapping and historical aerial imagery, the results of which are presented in Table 3.1.

For some map dates only partial site coverage is available and other maps span a range of dates (1887 for example). The dates shown in Table 3.1 are representative of the features on and off site at stages in the past. The descriptions are based on correlations between features on and/or off site from overlapping map date ranges.

**Table 3.1: Historical development and current land use of the site and surrounding area.**

Map Date (Scale)	On-site	Off-site
1881 (1:2,500)	The site comprises an undeveloped field	The surrounding area is generally undeveloped comprising a series of open fields. The village of Crick can be seen to the north of the site and properties labelled as 'Ballan' and 'Little Ballan' are located to the west, their purpose unknown. A woodland is located some 100m to the east running in a north-south orientation. A quarry is located 250m to the north-east and within the woodland. A potential track or road labelled 'traces of paving' is located some 100m to the west.
1881 (1:10,560)	No significant change.	No significant change. The larger scale shows the wider area to comprise open fields with woodlands to the north, east, and south
1887 (1:10,560) Partial Coverage	Site not covered in the mapping	Partial coverage only shows the land to the east of the site. No significant change, land uses comprise open fields and farm buildings 500m to the east.
1901 (1:2,500)	No significant change.	No significant change. The linear wood to the east is now recorded as 'Ballan Wood' and the quarry within the wood is no longer recorded.
1902 (1:10,560)	No significant change.	No significant change.
1903 (1:10,560)	No significant change.	No significant change.
1919 (1:10,560)	No significant change.	No significant change.
1903 (1:10,560)	No significant change.	No significant change.
1921 (1:2,500)	No significant change.	No significant change.
1924 (1:10,560)	Site not covered in the mapping	Only partial coverage to the east of the site, no significant change
1949 (1:10,560)	No significant change.	No significant change.
1964-1965 (1:2,500)	No significant change.	A new railway line and associated cutting is now present running north to south circa 200m to the west.
1967 (1:2,500)	No significant change.	The M4 has been constructed immediately to the north of the site running in a north-east to south-west orientation. Additionally, a road now traces the western boundary of the site, this is unlabelled but follows the line of Crick Road shown on modern maps.
1967 (1:10,560) Partial coverage	Site not covered in the mapping.	Partial coverage only shows the land to the north of the site. As shown in the 1:2,500 scale map a motorway has been constructed.
1968 (1:2,500)	No significant change.	No significant change.
1968-69 (1:10,560)	No significant change.	No significant change. Assumed residential properties are labelled within woodland between 400m and 600m to the northeast of the site including 'West View', 'Sunny Bank' and 'Woodside'.
1968-69 (1:10,560) Partial coverage	No significant change.	Partial coverage only shows the land south and north-east of the site. No significant change.
1988-90 (1:2,500) Partial Coverage	No significant change.	No significant change.
1994 (1:2,500) Partial Coverage	No significant change.	No significant change.

Map Date (Scale)	On-site	Off-site
2000 (Aerial Image)	No significant change. The site is shown to comprise open grassland only.	No significant change. The site is shown to be surrounded by open fields with the original M4 now labelled as the M48 motorway to the north and Crick Road running along the site's western boundary.
2001 (1:10,000)	No significant change.	No significant change. A poultry farm is shown some 800m to the north of the site and the railway line to the west now extends beyond Crick travels towards the north-west
2003 (1:1,250) Partial Coverage	No significant change.	No significant change.
2008 (Aerial Image)	The photo shows a linear feature connecting the north-western corner to the south-eastern corner. This is potentially a path worn into the ground by the movement of sheep. There is also a light brown oval shape adjacent to the sites eastern boundary details of which are unknown.	No significant change.
2009 (Aerial Image)	The linear feature and oval shape are no longer apparent, the site is once again shown to just be laid to grass.	No significant change.
2010 (1:10,000)	No significant change.	No significant change. The poultry farm previously identified is no longer labelled however the associated buildings are still present.
2017 (Aerial Image)	No significant change.	No significant change.
2020 (Aerial Image)	No significant change.	No significant change.

### 3.5 Unexploded ordnance

The Zetica Risk Map shows that the site is located within a Low Risk area defined as an area having '15 bombs per 1000 acres or less'.

However it should be noted that there is a known Luftwaffe target, the Caerwent Training Area, which is located 2km to the north-east of the site. , Caerwent Training Area was formerly known as the 'Royal Navy Propellant Factory' which was used to manufacture and store munitions for the Royal Navy between 1939 and 1992<sup>11</sup>. As such it cannot be discounted that the site may have been struck by UXOs dropped from aircraft targeting this nearby facility.

### 3.6 Other information

#### 3.6.1 Radon hazards

According to the Groundsure Report<sup>3</sup>, the highest band of radon risk on site is 3-5%, indicating that there is a 3-5% likelihood of any building on site exceeding the radon action level of 200Bq/m<sup>3</sup>. As the proposed development is not expected to comprise any below ground structures or significant enclosed and unventilated spaces, the risk from radon is considered to be low. However, due to the brick-and-mortar utility blocks, it is recommended that a Radon

<sup>11</sup> The Caerwent Community Web Site - Caerwent Historic Trust Report (archive.org) – Accessed December 2023



Search Address Report is obtained to determine the exact radon potential of the site, and appropriate protection put into place based on the results.

Should the proposed development change this risk should be reassessed.

### 3.6.2 Services and Utilities

At the time of writing this report, Mott MacDonald has not been provided with any service or utility plans for the site. Given the undeveloped nature of the site, it is considered unlikely that significant buried services are present beneath the site.

However, it should be noted that during the walkover overhead power lines were noted to be present traversing the site north to south which should be considered when planning any investigation or construction works. Additionally, animal water troughs and a manhole cover labelled 'Water' were noted to be present on site which will have buried pipes associated with them, the alignment of which should be determined prior to breaking ground.

### 3.6.3 Regulatory Information

Information on the site and surrounding area's land use, pollution incidents, and designations is presented in Table 3.2.

**Table 3.2: Land Use, Designated Sites and Pollution Incidents**

Aspect	Detail
<b>Agency and Hydrological</b>	
<b>Discharge Consents</b>	There are no discharge consents associated with the site. There are a total of 33 discharge consents within 420m of the site and all comprise the discharge of treated sewerage to groundwater or minor watercourses via an infiltration system.
<b>Local Authority Pollution Prevention Controls</b>	There are no local authority Pollution Prevention and Controls permits on or within 500m of the site
<b>Pollution Incidents</b>	There are no pollution incidents associated with the site however there are 6 within 500m with the nearest being located 205m to the north-west. This occurred in 2012 and comprised the release of sewage materials (grey water) and was noted to have had a significant impact on water but no impact on land or air quality.
<b>Waste</b>	
<b>Registered Landfill Sites</b>	There are no registered landfills on, or within 500m of the site.
<b>Waste Sites</b>	There are no records of any waste activities being carried out on site. The nearest such activity comprises a 'Waste Transfer Station' located 294m to the north with activities including <i>'screening, sorting, crushing and grading of material brought on to site, the product of these processes will be sold on.'</i>
<b>Waste Exemptions</b>	There are 7 waste exemptions recorded within 500m of the site. The nearest 5 of which are all located 196m to the north-west and is associated with the storage of waste in a secure place and the use of waste in construction by MCC. The remaining two are located 463m to the north-west and are for the disposal of waste through burning in the open.
<b>Potentially Infilled Land (Non-Water)</b>	There are no records of infilled land on, or within 500m of the site.
<b>Hazardous Substances</b>	
<b>Control of Major Accident Hazards Sites (COMAH)</b>	There are no recorded COMAH sites on, or within 500m of the site.
<b>Planning Hazardous Substance Consents</b>	There are no recorded Hazardous Substance Consents on, or within 500m of the site.
<b>Historic Land Uses</b>	
<b>Industrial land uses</b>	There are no recorded historical industrial land uses registered for the site. There are 14 located within 500m of the site with the nearest being located 181m to the

Aspect	Detail
	north-east and comprising 'cuttings', potentially associated with the quarry identified on the historical mapping.
<b>Energy Features</b>	There are no energy features recorded on the site. There are two electrical substations located within 500m of the site with the nearest being located 411m to the north-west
<b>Petrol Stations and garages</b>	There are no petrol stations or garages recorded on the site. There are two historic garages recorded within 500m of the site with the nearest being 311m to the north-west however this is recorded as being closed since 1967. The second is 313m to the north-west and is likely the same site that has been re-registered at a later date.
<b>Storage tanks</b>	There are no records of storage tanks on, or within 500m of the site.
<b>Military Land</b>	There are no records of military on, or within 500m of the site. The nearest such site is the Caerwent Training Area located some 2km to the north-west
<b>Current Industrial Land Uses</b>	
<b>Industrial land uses</b>	There are no records of current industrial land use for the site. The nearest industrial land use is the Celtic Fuel Oils Ltd facility 208m to the north
<b>Petrol Stations and garages</b>	There are no records of current or recent petrol stations on or within 500m of the site. There is a second-hand car dealer located in Crick some 326m to the north of the site that utilises a former petrol station forecourt as a vehicle storage area.
<b>Electricity Cables</b>	There are no records of underground high voltage electricity transmission cables on or within 500m of the site.
<b>Gas Pipelines</b>	There are no records of underground high pressure gas main on or within 500m of the site.
<b>Contaminated Land</b>	There are no records of land requiring remediation under Part 2a of the Environmental Protection Act 1990 on, or within 500m of the site.
<b>Regulated explosive sites</b>	There are no records sites registered and licensed to manufacture and store explosives on or within 500m of the site.
<b>Radioactive substances</b>	There are no records of the use or storage of radioactive substances on, or within 500m of the site.
<b>Hazardous Substances</b>	There are no records of sites licensed to store hazardous substances on or within 500m of the site.
<b>Sensitive Land Use</b>	
<b>Ancient Woodland</b>	There are no registered ancient woodlands recorded on site. The nearest such area comprised the Ballan Wood some 180m to the east.
<b>Local Nature Reserves</b>	The Saltings Local Nature Reserve is located circa 926m west of the site.
<b>Listed buildings</b>	There are no listed buildings within 500m of the site.
<b>World Heritage Sites</b>	There are two world heritage sites associated with the Antonine Wall recorded circa 47 – 233m north of the site.

### 3.7 Site reconnaissance

A walkover of the site was carried out on the 12<sup>th</sup> January 2024 during which the weather was cool and dry. The following observations were made:

- The site is generally flat and level and is covered in close grazed grass.
- Access to the site could be obtained by metal five-bar gates in the south-western and north-western corners, both of which open onto Crick Road to the west of the site.
- Aggregates were placed in the south-western site entrance, likely to consolidate the soils in an area of high traffic and prevent the tracking of mud onto the highways.
- The field was seen to have been actively grazed by sheep who had moved into the adjacent field during the walkover however access to the field remained available to them.
- The field boundaries adjacent to the road and M48 comprised wooden post and rail fencing with a wire stock fence also attached.

- Internal boundaries between fields comprised a wire stock fence only.
- Hedges were also present on all boundaries and comprised blackthorn, hawthorn and holly.
- A water utility man-hole cover was noted within 10m of the north-western entrance with its condition suggesting it had been constructed recently (little rust on the steel and almost not staining or algal growth on the concrete).
- Although closely grazed the grass all appeared to be healthy and of a uniform colour indicating consistent soil chemistry across the site.
- There were no areas of disturbed ground or debris that might indicate historic land uses outside of animal agriculture.
- Two animal water troughs were noted, one adjacent to the south-western site entrance and a second in the south-eastern corner adjacent to the gate connecting to an adjacent field, both of which were fed by a blue polythene water pipe, and
- The overhead lines noted on the aerial photography previously were confirmed to cross the site in a north-south orientation.

Based on the above observations, no specific sources of contamination were identified. The only evidence of land disturbance was the identified water utility manhole in the north-west, and the animal water troughs which are fed by a water supply pipe however the route of these supply pipes is not currently known.

The manhole lid was not lifted during the walkover; the depth and alignment of the utility as well as those of the water feed pipes for the troughs remains unknown. A photographic record from the walkover can be found in Appendix C.

## 4 Ground Conditions

### 4.1 Topsoil

Given the undeveloped nature of the site, and the lack of known historical developments within the site boundary, it is likely that topsoil is present across the whole site area.

### 4.2 Artificial ground

Made Ground has not been mapped in or in close proximity to the site. Given the current and historical land uses of the site, significant thicknesses of Made Ground at the site are not anticipated. However, localised Made Ground may be present along the northern boundary associated with the construction of the M4 motorway (now called the M48 motorway) and in the vicinity of the water main depending on how the trench was backfilled, however this is highly unlikely to represent a contaminant source.

### 4.3 Superficial deposits

The BGS GeoIndex indicates that superficial deposits are absent within the eastern part of the site. The western part of the site is shown to be underlain by River Terrace Deposits. These are described by the BGS Lexicon<sup>6</sup> as comprising '*Sand and gravel, locally with lenses of silt, clay or peat*'

In areas where no superficial deposits are recorded as being present it is highly likely that a thickness of completely weathered bedrock would be present overlying more competent rock at depth.

### 4.4 Bedrock geology

The BGS GeoIndex<sup>3</sup> shows that the site is completely underlain by bedrock comprising the Mercia Mudstone Group – Mudstone beneath the entirety of the site.

The Mercia Mudstone Group – Mudstone is described by the BGS Lexicon<sup>6</sup> as consisting of '*Dominantly red, less commonly green-grey, mudstones and subordinate siltstones with thick halite-bearing units in some basinal areas. Thin beds of gypsum/anhydrite are widespread; thin sandstones are also present*' these were formed during the mid to late Triassic.

### 4.5 Land mass movement

GeoIndex<sup>3</sup> does not identify land mass movement events on site, with no mass movement deposits within 500m.

### 4.6 Mining and quarrying

#### 4.6.1 Coal Mining

The Coal Authority Interactive Map Viewer<sup>7</sup> indicates that the site is not located within a Coal Mining Reporting Area.

#### 4.6.2 Non-coal Mining

The Groundsure report indicates that there are no known non-coal mining features on site. The following non-coal mining features have been recorded within 500m of the site.

- One ‘BritPit’ located 253m to the north-west comprising a ‘surface mineral working, sometimes termed a quarry, sand pit, clay pit, or opencast coal site’;
- 14 surface ground workings the closest of which is located 181m to the north-east and described as a ‘cutting’.

#### 4.7 BGS Ground Stability Hazards

Potential BGS Ground Stability Hazards highlighted within the Envirocheck Report are presented in Table 4.1.

**Table 4.1: BGS Ground Stability Hazards**

Ground Stability Hazard	Hazard Potential on Site
Collapsible Ground	Very Low
Compressible Ground	Negligible
Ground Dissolution	Negligible
Landslides	Low
Running Sands	Very Low
Shrinking or Swelling Clay	Very Low

#### 4.8 Hydrology and flooding

The nearest watercourse is an unnamed drainage channel located some 130m to the north-west of the site. This drains into the Nedern Brook designated by DataMap Wales<sup>12</sup> as a Main River (Water body ID: GB109056026880), located some 400m to the east which flows to the south before ultimately discharging into the Severn Estuary. There are no other surface water features in the vicinity of the site.

The Nedern Brook was last classified under the Water Framework Directive in 2016 and was classified as having a chemical rating of ‘Good’ and an ecological rating of ‘Poor’.

The Groundsure Report indicates that the site is not at risk from groundwater flooding, however a very limited area in the north of the site has a 1 in 1000 year risk of surface water flooding to a depth of between 0.1m and 0.3m. The land immediately to the west of the site is shown to be at a risk of surface water flooding with a 1 in 100 year period to a depth of greater than 1.0m.

#### 4.9 Hydrogeology

The superficial deposits, which are only present beneath the western half of the site, are categorised as a Secondary A aquifer. This is classified by the BGS as *‘Permeable layers capable of supporting water supplies at a local rather than strategic scale, and in some cases forming an important source of base flow to rivers. These are generally aquifers formerly classified as minor aquifers’*.

The bedrock geology underlying the site is classified as a Secondary B aquifer, described by the BGS as *‘Predominantly lower permeability layers which may store/yield limited amounts of groundwater due to localised features such as fissures, thin permeable horizons and weathering. These are generally the water-bearing parts of the former non-aquifers’*.

According to the Groundsure Report, the superficial and bedrock aquifers have been classified as high vulnerability aquifers, defined as comprising *‘Areas able to easily transmit pollution to groundwater. They are likely to be characterised by high leaching soils and the absence of low permeability superficial deposits’*.

<sup>12</sup> Home | DataMapWales (gov.wales) – Accessed December 2023

The site is located within a Source Protection Zone 4 (Zone of Special Interest) and although there are no groundwater abstractions on site, there is a single groundwater abstraction recorded some 400m to the south. This abstraction has an annual abstraction volume of 10,454m<sup>3</sup> from the Mercia Mudstone Group and is recorded as being for ‘general farming and domestic purposes’.

## 4.10 Historical Ground Investigations

Mott MacDonald is not aware of any historical ground investigations having been carried out within the site boundaries.

### 4.10.1 BGS Borehole Records

There are no BGS boreholes recorded within the site extent, however there are 9 exploratory hole locations recorded within approximately 500m of the site boundary.

A summary of relevant BGS boreholes located within approximately 500m of the site is presented below in Table 4.2 and the logs are provided in Appendix B.

**Table 4.2: Summary of BGS Borehole Records**

BGS Reference	Name	Year	Depth (m)	Approximate Distance (m) and Direction	Easting	Northing
ST48NE165	LONDON-SOUTH WALES MOTORWAY 95	1962	6.24	30m North	348927	189943
ST49SE36	LONDON-SOUTH WALES MOTORWAY 96	1962	6.24	168m North	349029	190100
ST48NE164	LONDON-SOUTH WALES MOTORWAY 94	1962	9.29	245m South- West	348712	189737
ST48NE163	LONDON-SOUTH WALES MOTORWAY 93	1962	9.14	254m West	348698	189774
ST49SE9	SEVEN BRIDGE APPROACH M37	None provided	6.10	310m North	349096	190233
ST48NE161	LONDON-SOUTH WALES MOTORWAY 92	1962	7.62	340m West	348626	189723
ST48NE162	LONDON-SOUTH WALES MOTORWAY 92A	1962	2.28	350m West	348620	189711
ST49SE8	SEVEN BRIDGE APPROACH M36	None provided	9.14	405m North	349135	190336
ST48NE160	LONDON-SOUTH WALES MOTORWAY 91	1962	3.42	495m South-West	348482	189655
ST48NE159	LONDON-SOUTH WALES MOTORWAY 90	1962	9.14	495m South-West	348475	189680

The available BGS boreholes indicate that the ground conditions within the wider area generally comprise Topsoil to a depth of up to 0.45m bgl, underlain by superficial deposits comprising brown and red-brown silts, clays and sands with occasional gravels and cobbles of sandstone considered by Mott MacDonald to represent the River Terrace Deposits. Bedrock was only encountered in four boreholes (ST49SE8, ST49SE9, ST48NE161 and ST48NE159) and comprised limestone, sandstone and mudstone, considered to be representative of the Mercia Mudstone Group underlying the site.

Given these historical boreholes would have been advanced on land of a similar use and geographic location to the site (prior to development) it is likely that the ground conditions recorded in the boreholes will be similar to those encountered on this site.

#### **4.11 Ground Gas Generation Potential**

Based on the available information it is not considered likely that the soils underlying the site have the potential to produce significant concentrations or quantities of ground gas that could pose a risk the sites end users. As such the risk from ground gas is not considered further.

Should significant deposits of organic materials, whether natural or anthropogenic in nature, be encountered during any future development work this assumption should be reconsidered.

## 5 Preliminary Ground Model

### 5.1.1 Ground Model

The historical site information and BGS Geological Mapping have been used to infer the potential ground conditions beneath the site, and a preliminary ground model is presented in Table 5.1.

**Table 5.1: Preliminary Ground Model**

Strata	Depth to Top (m)	Anticipated Thickness (m)	Typical Description
Topsoil	0.00	0.00 – 0.30	Anticipated to comprise brown sands silts, and clays with minor gravel content and rootlets.
River Terrace Deposits	0.00	0.00 – 4.60	Brown sandy clay or clayey sand with medium to fine gravels of sandstone, likely only present beneath the western half of the site.
Completely Weathered Mercia Mudstone Formation	0.00	0.00 – 8.50	Red-brown sandy gravelly clay. Gravels are fine to coarse sandstone fragments.
Mercia Mudstone Formation	2.30	>9.14 – Base unproven	Hard red white and grey marl, sandstone and dolomitic limestone.

Note: Depths have been assumed, based on near-by BGS boreholes, and as such may not accurately represent the conditions beneath the site.

### 5.2 Groundwater

There is no current information available to inform the groundwater conditions beneath the site area. Historical BGS boreholes do not record any groundwater strikes in any of the boreholes in the vicinity of the site to their maximum depth of 9.30m bgl.

Although unlikely to be encountered during the works groundwater, if encountered, would be expected to be flowing towards the south-west and the Nedern Brook.

### 5.3 Obstructions

Natural obstructions, such as cobbles or boulders, may also be present within the River Terrace Gravels and completely weather bedrock.

Buried water pipes are present within the central part of the site, the alignment of which is currently known.



## 6 Preliminary Contamination Risk Assessment

### 6.1 Preliminary Conceptual Model Methodology

Historical contaminated land is managed in the UK through Part 2A of the Environmental Protection Act (EPA) 1990<sup>13</sup> or, where development of a site is to take place, through the Town and Country Planning Act 1990<sup>14</sup>. The Town and Country Planning Act<sup>14</sup> requires that a site must be suitable for its intended use and that there are no significant risks to the environment following development. A developed site must be left in a condition that it cannot be determined as contaminated land under Part 2A.

This report adopts a strategy for the assessment of potential land contamination based on current government guidance contained in Land Contamination Risk Management (LCRM)<sup>15</sup> and CIRIA Report C552<sup>16</sup>.

A key element in the risk assessment for land contamination is the development of a Conceptual Site Model (CSM) which may be refined or revised as more information and understanding is obtained through the risk assessment process. The CSM is described in terms of the contaminant 'Source', transport 'Pathways' and possible 'Receptors' that may be present. These are defined as:

- Sources (S) are potential or known contaminant sources e.g. arising from a former land use.
- Pathways (P) are environmental systems through which a contaminant could migrate e.g. air, groundwater or direct contact; and
- Receptors (R) are sensitive environmental or human receptors that could be adversely affected by a contaminant e.g. site occupiers, groundwater resources.

Where a source, relevant pathway and receptor are present, a contaminant linkage is present which requires further investigation and risk assessment.

The conceptual model and qualitative risk assessment are presented in Table 6.1. The risk assessment process is described in Section 6.2.

It is anticipated that, as part of any future ground investigation works, geoenvironmental laboratory testing will be undertaken on samples of soil, rock and water recovered as during the intrusive ground investigation, to inform further development of the potential risks at the site.

### 6.2 Preliminary Risk Assessment Methodology

For each potential contaminant linkage identified within the conceptual model presented in this report, the potential risk has been evaluated for ecological receptors, buildings and construction/maintenance workers and the final end users. A Preliminary Qualitative Risk Assessment has been prepared, based on the probability of the pollution event, and the severity it may have on site users and the environment. R&D Publication 66<sup>17</sup> (NHBC, ES, CIEH, 2008) sets out the classification used in the Preliminary Qualitative Risk Assessment. The

---

<sup>13</sup> [Environmental Protection Act 1990 \(legislation.gov.uk\)](https://www.legislation.gov.uk). Accessed February 2024

<sup>14</sup> [Town and Country Planning Act 1990 \(legislation.gov.uk\)](https://www.legislation.gov.uk). Accessed February 2024

<sup>15</sup> [Land contamination risk management \(LCRM\) - GOV.UK \(www.gov.uk\)](https://www.gov.uk). Accessed February 2024

<sup>16</sup> CIRIA. Contaminated land risk assessment. A guide to good practice (C552). Accessed February 2024

<sup>17</sup> [R&D66 VOL 1 Guidance for the Safe Development of Housing on Land Affected by Contamination \(nhbc.co.uk\)](https://www.nhbc.co.uk). Accessed February 2024

classification has been developed from DOE Guide to Risk Assessment and Risk Management for Environmental Protection and the Statutory Guidance on Contaminated Land (Welsh Government 2012<sup>18</sup>). The key to the classification is that the designation of risk is based upon the consideration of both:

- The magnitude of the potential consequence (i.e. severity); and
  - Takes into account both the potential severity of the hazard and the sensitivity of the receptor
- The magnitude of probability (i.e. likelihood)

**Table 6.1: Classification of consequence**

Classification	Definition of Consequence
Severe	Highly elevated concentrations likely to result in 'significant harm' to human health as defined by the EPA 1990, Part 2A, if exposure occurs. Equivalent to EA Category 1 pollution incident including persistent and/or extensive effects on water quality; leading to closure of a potable abstraction point; major impact on amenity value or major damage to agriculture or commerce. Major damage to aquatic or other ecosystems, which is likely to result in a substantial adverse change in its functioning or harm to a species of special interest that endangers the long - term maintenance of the population. Catastrophic damage to crops, buildings or property.
Medium	Elevated concentrations which could result in 'significant harm' to human health as defined by the EPA 1990, Part 2A if exposure occurs. Equivalent to EA Category 2 pollution incident including significant effect on water quality; notification required to abstractors; reduction in amenity value or significant damage to agriculture or commerce. Significant damage to aquatic or other ecosystems, which may result in a substantial adverse change in its functioning or harm to a species of special interest that may endanger the long - term maintenance of the population. Significant damage to crops, buildings or property.
Mild	Exposure to human health unlikely to lead to 'significant harm'. Equivalent to EA Category 3 pollution incident including minimal or short-lived effect on water quality; marginal effect on amenity value, agriculture or commerce. Minor or short-lived damage to aquatic or other ecosystems, which is unlikely to result in a substantial adverse change in its functioning or harm to a species of special interest that would endanger the long - term maintenance of the population. Minor damage to crops, buildings or property.
Minor	No measurable effect on humans. Equivalent to insubstantial pollution incident with no observed effect on water quality or ecosystems. Repairable effects of damage to buildings, structures and services.

The probability of contamination risks occurring is classified in accordance with Table 6.2. A contaminant linkage must first be established before probability is classified. If there is no contaminant linkage, then there is no potential risk and therefore no requirement to apply tests for probability and consequence.

**Table 6.2: Classification of probability**

Classification	Definition
High Likelihood	There is contaminant linkage and an event would appear very likely in the short - term and almost inevitable over the long - term, or there is evidence at the receptor of harm or pollution.
Likely	There is contaminant linkage and all the elements are present and in the right place which means that it is probable that an event will occur. Circumstances are such that an event is not inevitable, but possible in the short - term and likely over the long - term.
Low Likelihood	There is contaminant linkage and circumstances are possible under which an event could occur. However, it is by no means certain that even over a long period such an event would take place and is less likely in the shorter term.
Unlikely	There is contaminant linkage, but circumstances are such that it is improbable that an event would occur even in the very long - term.

<sup>18</sup> [Contaminated Land Statutory Guidance – 2011 version \(gov.wales\)](#) – Accessed February 2024

For each possible contaminant linkage (source – pathway – receptor) identified, the potential risk can be evaluated based upon the following probability x consequence matrix shown in Table 6.3.

**Table 6.3: Overall Contamination Risk Matrix**

		Consequence			
		Severe	Medium	Mild	Minor
Probability	High Likelihood	Very high risk	High risk	Moderate risk	Moderate / low risk
	Likely	High risk	Moderate risk	Moderate / low risk	Low risk
	Low Likelihood	Moderate risk	Moderate / low risk	Low risk	Very low risk
	Unlikely	Moderate / low risk	Low risk	Very low risk	Very low risk

R&D 66:2008 presents definitions of the risk categories, together with the investigatory and remedial actions that are likely to be necessary in each case. These definitions are reproduced in Table 6.4. These risk categories apply to each contaminant linkage, not simply to each hazard or receptor.

**Table 6.4: Definition of Risk Categories and Likely Action Required**

Risk Category	Definition and Likely Actions
Very high	There is a high probability that severe harm could arise to a designated receptor from an identified hazard at the site without remediation action OR there is evidence that severe harm to a designated receptor is already occurring. Realisation of that risk is likely to present a substantial liability to be site owner/or occupier. Investigation is required as a matter of urgency and remediation works likely to follow in the short - term.
High	Harm is likely to arise to a designated receptor from an identified hazard at the site without remediation action. Realisation of the risk is likely to present a substantial liability to the site owner/or occupier. Investigation is required as a matter of urgency to clarify the risk. Remediation works may be necessary in the short - term and are likely over the longer term.
Moderate	It is possible that harm could arise to a designated receptor from an identified hazard. However, it is either relatively unlikely that any such harm would be severe, and if any harm were to occur it is more likely, that the harm would be relatively mild. Further investigative work is normally required to clarify the risk and to determine the potential liability to site owner/occupier. Some remediation works may be required in the longer term.
Low	It is possible that harm could arise to a designated receptor from identified hazard, but it is likely at worst, that this harm if realised would normally be mild. It is unlikely that the site owner/or occupier would face substantial liabilities from such a risk. Further investigative work (which is likely to be limited) to clarify the risk may be required. Any subsequent remediation works are likely to be relatively limited.
Very low	It is a low possibility that harm could arise to a designated receptor, but it is likely at worst, that this harm if realised would normally be mild or minor.

### 6.3 Preliminary Conceptual Site Model

The following sources, pathways and receptors have been considered based on the available information for this site.

#### Potential Sources

**S1:** Sources associated with potential Made Ground on site associated with the site entrance and installation of water utility pipes.

**S2:** Sources associated with offsite activities in the vicinity of the site including the construction and use of the M48 motorway.

**Potential Pathways**

**P1:** Human uptake pathways including ingestion, inhalation and direct contact.

**P2:** Man-made pathways – e.g., excavations, buried foundations

**P3:** Vertical and horizontal migration of contaminants in the subsurface.

**P4:** Overland flow - surface runoff.

**Potential Receptors**

**R1:** Human receptors – site end users.

**R2:** Construction and maintenance worker.

**R3:** Groundwater – Superficial Secondary A and Bedrock Secondary B aquifers.

**R4:** Environmental receptors - including Nedern Brook and associated tributaries.

**Table 6.5: Preliminary Conceptual Site Model**

Potential Sources	Potential Pathways	Potential Receptors	Consequence	Likelihood	Risk Classification
<b>S1:</b> Sources associated with potential Made Ground on site associated with the site entrance and installation of water utility pipes.	<b>P1:</b> Human uptake pathways Ingestion Inhalation Direct contact	<b>R1:</b> End users – future site users	<b>Mild</b> – Contaminants present in the soil could pose a health risk to site users. Any contaminants present are unlikely to be present in sufficiently high concentrations as to pose a risk of significant harm.	<b>Unlikely</b> – There is no current evidence that significant contaminant sources exist, and the site will have a transient population so the likelihood of residents growing produce on site is low. Extent of Made Ground is expected to be highly limited in extent.	Very Low
		<b>R2:</b> Construction and maintenance workers.			<b>Low Likelihood</b> – Although limited in extent, construction and maintenance workers are likely come into contact with any impacted soil during any construction or maintenance works. However, if present this will be mitigated by the Contractor though appropriate and safe working methodology.
	<b>P2:</b> Man-made pathways <b>P3:</b> Vertical and horizontal migration of contaminants in the subsurface	<b>R3:</b> Groundwater – Secondary A and B Aquifers	<b>Minor</b> – Contaminants on site are unlikely to be present in sufficiently high volumes or concentrations so as to pose a risk to the underlying aquifers.	<b>Unlikely</b> – Sources are expected to be of limited extent and nor are they expected to be sufficiently leachable so as to become mobile in the environment.	Very Low
<b>S2:</b> Sources associated with offsite activities in the vicinity of the site including the construction and use of the M48 motorway.	<b>P1:</b> Human uptake pathways Ingestion Inhalation Direct contact	<b>R4:</b> Environmental receptors – including Nedern Brook and associated tributaries.	<b>Minor</b> – Contaminants on site are unlikely to be present in sufficiently high volumes or concentrations so as to pose a risk to the underlying aquifers.	<b>Unlikely</b> – Sources are expected to be of limited extent and nor are they expected to be sufficiently leachable so as to become mobile in the environment. Unlikely that sufficient runoff would be produced to carry contaminants as far as the identified receptors	Very Low
		<b>R1:</b> End users – future site users			<b>Mild</b> – Contaminants present in the groundwater could pose a health risk to site users. Any contaminants present are unlikely to be present in sufficiently high concentrations as to pose a risk of significant harm.
	<b>P2:</b> Man-made pathways <b>P3:</b> Vertical and horizontal migration of contaminants in the subsurface	<b>R3:</b> Groundwater – Secondary A and B Aquifers	<b>Minor</b> –Contaminants on site are unlikely to be present in sufficiently high volumes or concentrations to pose a risk to the underlying aquifers.	<b>Unlikely</b> – Sources are expected to be of limited extent and nor are they expected to be sufficiently leachable so as to become mobile in the environment.	
<b>P3:</b> Vertical and horizontal migration of contaminants in the subsurface <b>P4:</b> Overland flow - surface runoff.	<b>R4:</b> Environmental receptors – including Nedern Brook and associated tributaries.	<b>Minor</b> –Contaminants on site are unlikely to be present in sufficiently high volumes or concentrations so as to pose a risk to the underlying aquifers.	<b>Unlikely</b> – Sources are expected to be of limited extent and nor are they expected to be sufficiently leachable so as to become mobile in the environment. Unlikely that sufficient runoff would be produced to carry contaminants as far as the identified receptors	Very Low	

## 7 Conclusions

Mott MacDonald has been commissioned by Monmouthshire County Council to produce a Phase 1 Desk Study for the proposed development of a new Gypsy & Traveller Site camp at Bradbury Farm, Crick.

The following conclusions are based on the understanding that the proposed development comprises the construction of a service block containing toilets, showers, cooking and laundry facilities, with access roads to a number of plots.

It is recommended that this desk study be updated should the scheme proposals be refined or changed.

### 7.1 Ground Conditions

The ground conditions anticipated to underlie the site have been inferred from available geological mapping and supplemented by the findings from historical off site BGS exploratory holes. A preliminary ground model has been developed for the site. The conditions underlying the site are anticipated to comprise the following:

- Topsoil: Anticipated to comprise brown sands silts and clays with minor gravel inclusions present beneath the whole site area
- Possible Localised Made Ground: Anticipated to be present locally within the site.
- River Terrace Deposits: Anticipated to comprise brown sandy clay or clayey sand with medium to fine gravels of sandstone
- Completely Weathered Bedrock: Red-brown sandy gravelly clay. Gravels are fine to coarse sandstone fragments.
- Bedrock: Anticipated to hard red, white and grey marl, sandstone and dolomitic limestone.
- Groundwater levels beneath the site are currently unknown with the historic borehole logs not recording groundwater to depths as great as 9.30m bgl.

#### 7.1.1 Geo-environmental

A preliminary contaminated land risk assessment has been developed for the site to identify potential contaminant sources, pathways and receptors associated with the proposed development.

##### 7.1.1.1 Human Health

Due to the absence of any significant sources of contamination on site the risk to human health is considered to be 'very low' for the sites end users and 'low' for construction and maintenance workers. Should any soils be identified on site during the works that are not consistent with the likely ground conditions described within this report works should stop and samples of the suspect materials should be recovered and sent for chemical testing with a suitable risk assessment carried out.

##### 7.1.1.2 Groundwater

It is not considered likely that the ground conditions on site pose a significant risk to either the groundwater underlying the site nor surface water features in the vicinity of the site. Additionally, it is not considered likely that the groundwater beneath the site will be acting as a contaminant source.

### 7.1.1.3 Radon

The highest band of radon risk on site is 3-5%, indicating that there is a 3-5% likelihood of any building on site exceeding Radon Action Level of 200Bq/m<sup>3</sup>.

### 7.1.1.4 Waste Classification and Disposal

At the time of writing a soil mass balance for the project had not been produced for the proposed development. However, there is potential for the proposed development to generate surplus soils. Where possible, these soils should be either reused on site or sent to a waste recovery facility for recycling. All soil to be reused or disposed of will need to be tested to confirm suitability for reuse and/or waste classification. This testing should be carried out following completion of the excavation works and prior to reuse or disposal.

## 7.1.2 Objective and format of any investigation

As the site has been used as an undeveloped field with little ground disturbance that may have led to the presence of contamination sources on site and as such it is considered that the risk of active contaminants pathways to be present on site is low to very low. As such, an intrusive ground investigation is not considered necessary as the risk geoenvironmental risks are not considered to be sufficiently high. However, ground investigation may be required, to inform geotechnical design, should the scheme be progressed beyond the current feasibility stage.

During any future stages of the scheme, should ground conditions be encountered which are outside of those detailed within this report, works should be stopped, samples of the suspect materials sampled and the geoenvironmental risks reassessed. The processes to be followed in the event of uncovering unexpected contamination should be detailed within a Discovery Strategy and provided to the contractor prior to commencing works.

## 7.2 Recommendations

### 7.2.1 Utility Survey

There is no information on the location of buried services within or adjacent to the site, however during the walkover, a manhole associated with a water main was identified as were animal water troughs and their associated water supplies. Additionally, overhead power lines were identified running north to south through the centre of the site. It is recommended that a utilities search is undertaken at an early stage in the development of the scheme's design in order obtain details such the line and depth of buried services and the required standoff distances from the overhead power lines.

### 7.2.2 Radon

A Radon Search Address Report should be obtained to determine the exact radon potential of the site, and appropriate protection put into place based on the results.

### 7.2.3 Discovery Strategy

A Discovery Strategy should be produced which will detail the steps to be followed should previously unidentified contamination be discovered, if the scheme progresses to the construction stage. This should include the following:

- Potential indicators of contamination (visual or olfactory);
- Quarantine procedures to put in place;
- Testing requirements (number of samples, testing suites etc);

- Geoenvironmental assessment procedures; and
- Materials tracking and verification.



# **A. Groundsure Environmental and Geo Insight Report**

BALLAN COTTAGE, LITTLE BALLAN LANE, CRICK, NP26 5UN

**Order Details**

**Date:** 05/12/2023  
**Your ref:** Land\_at\_Bradbury\_Farm\_Crick  
**Our Ref:** GS-774-2DA-JKL-FL5

**Site Details**

**Location:** 348995 189835  
**Area:** 1.79 ha  
**Authority:** [Sir Fynwy - Monmouthshire County Council](#) ↗



© Crown copyright and database rights 2023. Ordnance Survey licence 100035207

**Summary of findings**

[p. 2 >](#) **Aerial image**

[p. 9 >](#)

**OS MasterMap site plan**

[p.14 >](#) [groundsure.com/insightuserguide](https://groundsure.com/insightuserguide) ↗

## Summary of findings

Page	Section	<a href="#">Past land use &gt;</a>	On site	0-50m	50-250m	250-500m	500-2000m
<a href="#">15 &gt;</a>	<a href="#">1.1 &gt;</a>	<a href="#">Historical industrial land uses &gt;</a>	0	0	10	4	-
16	1.2	Historical tanks	0	0	0	0	-
<a href="#">16 &gt;</a>	<a href="#">1.3 &gt;</a>	<a href="#">Historical energy features &gt;</a>	0	0	0	2	-
17	1.4	Historical petrol stations	0	0	0	0	-
<a href="#">17 &gt;</a>	<a href="#">1.5 &gt;</a>	<a href="#">Historical garages &gt;</a>	0	0	0	2	-
18	1.6	Historical military land	0	0	0	0	-
Page	Section	<a href="#">Past land use - un-grouped &gt;</a>	On site	0-50m	50-250m	250-500m	500-2000m
<a href="#">19 &gt;</a>	<a href="#">2.1 &gt;</a>	<a href="#">Historical industrial land uses &gt;</a>	0	0	15	7	-
20	2.2	Historical tanks	0	0	0	0	-
<a href="#">21 &gt;</a>	<a href="#">2.3 &gt;</a>	<a href="#">Historical energy features &gt;</a>	0	0	0	2	-
21	2.4	Historical petrol stations	0	0	0	0	-
<a href="#">21 &gt;</a>	<a href="#">2.5 &gt;</a>	<a href="#">Historical garages &gt;</a>	0	0	0	3	-
Page	Section	<a href="#">Waste and landfill &gt;</a>	On site	0-50m	50-250m	250-500m	500-2000m
22	3.1	Active or recent landfill	0	0	0	0	-
22	3.2	Historical landfill (BGS records)	0	0	0	0	-
23	3.3	Historical landfill (LA/mapping records)	0	0	0	0	-
23	3.4	Historical landfill (EA/NRW records)	0	0	0	0	-
<a href="#">23 &gt;</a>	<a href="#">3.5 &gt;</a>	<a href="#">Historical waste sites &gt;</a>	0	0	0	1	-
23	3.6	Licensed waste sites	0	0	0	0	-
<a href="#">24 &gt;</a>	<a href="#">3.7 &gt;</a>	<a href="#">Waste exemptions &gt;</a>	0	0	5	2	-
Page	Section	<a href="#">Current industrial land use &gt;</a>	On site	0-50m	50-250m	250-500m	500-2000m
<a href="#">26 &gt;</a>	<a href="#">4.1 &gt;</a>	<a href="#">Recent industrial land uses &gt;</a>	0	0	1	-	-
27	4.2	Current or recent petrol stations	0	0	0	0	-
27	4.3	Electricity cables	0	0	0	0	-
27	4.4	Gas pipelines	0	0	0	0	-
27	4.5	Sites determined as Contaminated Land	0	0	0	0	-



27	4.6	Control of Major Accident Hazards (COMAH)	0	0	0	0	-
28	4.7	Regulated explosive sites	0	0	0	0	-
28	4.8	Hazardous substance storage/usage	0	0	0	0	-
28	4.9	Historical licensed industrial activities (IPC)	0	0	0	0	-
28	4.10	Licensed industrial activities (Part A(1))	0	0	0	0	-
28	4.11	Licensed pollutant release (Part A(2)/B)	0	0	0	0	-
29	4.12	Radioactive Substance Authorisations	0	0	0	0	-
<b>29 &gt;</b>	<b>4.13 &gt;</b>	<b><u>Licensed Discharges to controlled waters &gt;</u></b>	0	0	6	27	-
34	4.14	Pollutant release to surface waters (Red List)	0	0	0	0	-
35	4.15	Pollutant release to public sewer	0	0	0	0	-
35	4.16	List 1 Dangerous Substances	0	0	0	0	-
35	4.17	List 2 Dangerous Substances	0	0	0	0	-
<b>35 &gt;</b>	<b>4.18 &gt;</b>	<b><u>Pollution Incidents (EA/NRW) &gt;</u></b>	0	0	1	5	-
36	4.19	Pollution inventory substances	0	0	0	0	-
36	4.20	Pollution inventory waste transfers	0	0	0	0	-
37	4.21	Pollution inventory radioactive waste	0	0	0	0	-
Page	Section	<b><u>Hydrogeology &gt;</u></b>	On site	0-50m	50-250m	250-500m	500-2000m
<b>38 &gt;</b>	<b>5.1 &gt;</b>	<b><u>Superficial aquifer &gt;</u></b>	Identified (within 500m)				
<b>40 &gt;</b>	<b>5.2 &gt;</b>	<b><u>Bedrock aquifer &gt;</u></b>	Identified (within 500m)				
<b>42 &gt;</b>	<b>5.3 &gt;</b>	<b><u>Groundwater vulnerability &gt;</u></b>	Identified (within 50m)				
<b>44 &gt;</b>	<b>5.4 &gt;</b>	<b><u>Groundwater vulnerability- soluble rock risk &gt;</u></b>	Identified (within 0m)				
44	5.5	Groundwater vulnerability- local information	None (within 0m)				
<b>45 &gt;</b>	<b>5.6 &gt;</b>	<b><u>Groundwater abstractions &gt;</u></b>	0	0	0	6	2
<b>47 &gt;</b>	<b>5.7 &gt;</b>	<b><u>Surface water abstractions &gt;</u></b>	0	0	0	0	3
48	5.8	Potable abstractions	0	0	0	0	0
<b>49 &gt;</b>	<b>5.9 &gt;</b>	<b><u>Source Protection Zones &gt;</u></b>	1	0	0	0	-
49	5.10	Source Protection Zones (confined aquifer)	0	0	0	0	-
Page	Section	<b><u>Hydrology &gt;</u></b>	On site	0-50m	50-250m	250-500m	500-2000m
<b>50 &gt;</b>	<b>6.1 &gt;</b>	<b><u>Water Network (OS MasterMap) &gt;</u></b>	0	0	5	-	-



<a href="#">51</a> >	<a href="#">6.2</a> >	<a href="#">Surface water features</a> >	0	0	4	-	-
<a href="#">51</a> >	<a href="#">6.3</a> >	<a href="#">WFD Surface water body catchments</a> >	1	-	-	-	-
<a href="#">52</a> >	<a href="#">6.4</a> >	<a href="#">WFD Surface water bodies</a> >	0	0	0	-	-
<a href="#">52</a> >	<a href="#">6.5</a> >	<a href="#">WFD Groundwater bodies</a> >	1	-	-	-	-
Page	Section	River and coastal flooding	On site	0-50m	50-250m	250-500m	500-2000m
53	7.1	Risk of flooding from rivers and the sea	None (within 50m)				
53	7.2	Historical Flood Events	0	0	0	-	-
53	7.3	Flood Defences	0	0	0	-	-
54	7.4	Areas Benefiting from Flood Defences	0	0	0	-	-
54	7.5	Flood Storage Areas	0	0	0	-	-
55	7.6	Flood Zone 2	None (within 50m)				
55	7.7	Flood Zone 3	None (within 50m)				
Page	Section	<a href="#">Surface water flooding</a> >					
<a href="#">56</a> >	<a href="#">8.1</a> >	<a href="#">Surface water flooding</a> >	1 in 30 year, 0.3m - 1.0m (within 50m)				
Page	Section	<a href="#">Groundwater flooding</a> >					
<a href="#">58</a> >	<a href="#">9.1</a> >	<a href="#">Groundwater flooding</a> >	Low (within 50m)				
Page	Section	<a href="#">Environmental designations</a> >	On site	0-50m	50-250m	250-500m	500-2000m
<a href="#">59</a> >	<a href="#">10.1</a> >	<a href="#">Sites of Special Scientific Interest (SSSI)</a> >	0	0	0	1	3
60	10.2	Conserved wetland sites (Ramsar sites)	0	0	0	0	0
60	10.3	Special Areas of Conservation (SAC)	0	0	0	0	0
60	10.4	Special Protection Areas (SPA)	0	0	0	0	0
61	10.5	National Nature Reserves (NNR)	0	0	0	0	0
61	10.6	Local Nature Reserves (LNR)	0	0	0	0	0
<a href="#">61</a> >	<a href="#">10.7</a> >	<a href="#">Designated Ancient Woodland</a> >	0	0	7	2	60
64	10.8	Biosphere Reserves	0	0	0	0	0
<a href="#">64</a> >	<a href="#">10.9</a> >	<a href="#">Forest Parks</a> >	0	0	0	0	1
64	10.10	Marine Conservation Zones	0	0	0	0	0
65	10.11	Green Belt	0	0	0	0	0
65	10.12	Proposed Ramsar sites	0	0	0	0	0



65	10.13	Possible Special Areas of Conservation (pSAC)	0	0	0	0	0
65	10.14	Potential Special Protection Areas (pSPA)	0	0	0	0	0
65	10.15	Nitrate Sensitive Areas	0	0	0	0	0
66	10.16	Nitrate Vulnerable Zones	0	0	0	0	0
<b>67 &gt;</b>	<b>10.17 &gt;</b>	<b><u>SSSI Impact Risk Zones &gt;</u></b>	1	-	-	-	-
68	10.18	SSSI Units	0	0	0	0	0
Page	Section	<b><u>Visual and cultural designations &gt;</u></b>	On site	0-50m	50-250m	250-500m	500-2000m
69	11.1	World Heritage Sites	0	0	0	-	-
70	11.2	Area of Outstanding Natural Beauty	0	0	0	-	-
70	11.3	National Parks	0	0	0	-	-
70	11.4	Listed Buildings	0	0	0	-	-
70	11.5	Conservation Areas	0	0	0	-	-
<b>71 &gt;</b>	<b>11.6 &gt;</b>	<b><u>Scheduled Ancient Monuments &gt;</u></b>	0	0	1	-	-
71	11.7	Registered Parks and Gardens	0	0	0	-	-
Page	Section	<b><u>Agricultural designations &gt;</u></b>	On site	0-50m	50-250m	250-500m	500-2000m
<b>72 &gt;</b>	<b>12.1 &gt;</b>	<b><u>Agricultural Land Classification &gt;</u></b>	Grade 3b (within 250m)				
73	12.2	Open Access Land	0	0	0	-	-
73	12.3	Tree Felling Licences	0	0	0	-	-
73	12.4	Environmental Stewardship Schemes	0	0	0	-	-
74	12.5	Countryside Stewardship Schemes	0	0	0	-	-
Page	Section	<b><u>Habitat designations</u></b>	On site	0-50m	50-250m	250-500m	500-2000m
75	13.1	Priority Habitat Inventory	0	0	0	-	-
75	13.2	Habitat Networks	0	0	0	-	-
75	13.3	Open Mosaic Habitat	0	0	0	-	-
75	13.4	Limestone Pavement Orders	0	0	0	-	-
Page	Section	<b><u>Geology 1:10,000 scale &gt;</u></b>	On site	0-50m	50-250m	250-500m	500-2000m
<b>76 &gt;</b>	<b>14.1 &gt;</b>	<b><u>10k Availability &gt;</u></b>	Identified (within 500m)				
77	14.2	Artificial and made ground (10k)	0	0	0	0	-
<b>78 &gt;</b>	<b>14.3 &gt;</b>	<b><u>Superficial geology (10k) &gt;</u></b>	1	0	5	0	-

79	14.4	Landslip (10k)	0	0	0	0	-
<a href="#">80</a> >	<a href="#">14.5</a> >	<a href="#">Bedrock geology (10k)</a> >	1	1	5	8	-
<a href="#">81</a> >	<a href="#">14.6</a> >	<a href="#">Bedrock faults and other linear features (10k)</a> >	0	0	0	3	-
Page	Section	<a href="#">Geology 1:50,000 scale</a> >	On site	0-50m	50-250m	250-500m	500-2000m
<a href="#">83</a> >	<a href="#">15.1</a> >	<a href="#">50k Availability</a> >	Identified (within 500m)				
84	15.2	Artificial and made ground (50k)	0	0	0	0	-
84	15.3	Artificial ground permeability (50k)	0	0	-	-	-
<a href="#">85</a> >	<a href="#">15.4</a> >	<a href="#">Superficial geology (50k)</a> >	1	0	2	0	-
<a href="#">86</a> >	<a href="#">15.5</a> >	<a href="#">Superficial permeability (50k)</a> >	Identified (within 50m)				
86	15.6	Landslip (50k)	0	0	0	0	-
86	15.7	Landslip permeability (50k)	None (within 50m)				
<a href="#">87</a> >	<a href="#">15.8</a> >	<a href="#">Bedrock geology (50k)</a> >	2	0	3	4	-
<a href="#">88</a> >	<a href="#">15.9</a> >	<a href="#">Bedrock permeability (50k)</a> >	Identified (within 50m)				
<a href="#">88</a> >	<a href="#">15.10</a> >	<a href="#">Bedrock faults and other linear features (50k)</a> >	1	0	0	3	-
Page	Section	<a href="#">Boreholes</a> >	On site	0-50m	50-250m	250-500m	500-2000m
<a href="#">90</a> >	<a href="#">16.1</a> >	<a href="#">BGS Boreholes</a> >	0	1	3	-	-
Page	Section	<a href="#">Natural ground subsidence</a> >					
<a href="#">92</a> >	<a href="#">17.1</a> >	<a href="#">Shrink swell clays</a> >	Very low (within 50m)				
<a href="#">93</a> >	<a href="#">17.2</a> >	<a href="#">Running sands</a> >	Very low (within 50m)				
<a href="#">95</a> >	<a href="#">17.3</a> >	<a href="#">Compressible deposits</a> >	Negligible (within 50m)				
<a href="#">96</a> >	<a href="#">17.4</a> >	<a href="#">Collapsible deposits</a> >	Very low (within 50m)				
<a href="#">97</a> >	<a href="#">17.5</a> >	<a href="#">Landslides</a> >	Low (within 50m)				
<a href="#">99</a> >	<a href="#">17.6</a> >	<a href="#">Ground dissolution of soluble rocks</a> >	Negligible (within 50m)				
Page	Section	<a href="#">Mining and ground workings</a> >	On site	0-50m	50-250m	250-500m	500-2000m
<a href="#">101</a> >	<a href="#">18.1</a> >	<a href="#">BritPits</a> >	0	0	0	1	-
<a href="#">102</a> >	<a href="#">18.2</a> >	<a href="#">Surface ground workings</a> >	0	0	14	-	-
103	18.3	Underground workings	0	0	0	0	0
103	18.4	Underground mining extents	0	0	0	0	-
103	18.5	Historical Mineral Planning Areas	0	0	0	0	-



<a href="#">103</a> >	<a href="#">18.6</a> >	<a href="#">Non-coal mining</a> >	0	0	2	1	6
105	18.7	JPB mining areas	None (within 0m)				
105	18.8	The Coal Authority non-coal mining	0	0	0	0	-
105	18.9	Researched mining	0	0	0	0	-
105	18.10	Mining record office plans	0	0	0	0	-
106	18.11	BGS mine plans	0	0	0	0	-
106	18.12	Coal mining	None (within 0m)				
106	18.13	Brine areas	None (within 0m)				
106	18.14	Gypsum areas	None (within 0m)				
106	18.15	Tin mining	None (within 0m)				
107	18.16	Clay mining	None (within 0m)				
Page	Section	<a href="#">Ground cavities and sinkholes</a> >	On site	0-50m	50-250m	250-500m	500-2000m
<a href="#">108</a> >	<a href="#">19.1</a> >	<a href="#">Natural cavities</a> >	0	0	0	1	-
109	19.2	Mining cavities	0	0	0	0	0
109	19.3	Reported recent incidents	0	0	0	0	-
109	19.4	Historical incidents	0	0	0	0	-
109	19.5	National karst database	0	0	0	0	-
Page	Section	<a href="#">Radon</a> >					
<a href="#">111</a> >	<a href="#">20.1</a> >	<a href="#">Radon</a> >	Between 3% and 5% (within 0m)				
Page	Section	<a href="#">Soil chemistry</a> >	On site	0-50m	50-250m	250-500m	500-2000m
<a href="#">113</a> >	<a href="#">21.1</a> >	<a href="#">BGS Estimated Background Soil Chemistry</a> >	7	3	-	-	-
114	21.2	BGS Estimated Urban Soil Chemistry	0	0	-	-	-
114	21.3	BGS Measured Urban Soil Chemistry	0	0	-	-	-
Page	Section	<a href="#">Railway infrastructure and projects</a> >	On site	0-50m	50-250m	250-500m	500-2000m
115	22.1	Underground railways (London)	0	0	0	-	-
115	22.2	Underground railways (Non-London)	0	0	0	-	-
116	22.3	Railway tunnels	0	0	0	-	-
116	22.4	Historical railway and tunnel features	0	0	0	-	-
116	22.5	Royal Mail tunnels	0	0	0	-	-



116	22.6	Historical railways	0	0	0	-	-
<a href="#">116</a> >	<a href="#">22.7</a> >	<a href="#">Railways</a> >	0	0	3	-	-
117	22.8	Crossrail 1	0	0	0	0	-
117	22.9	Crossrail 2	0	0	0	0	-
117	22.10	HS2	0	0	0	0	-

## Recent aerial photograph

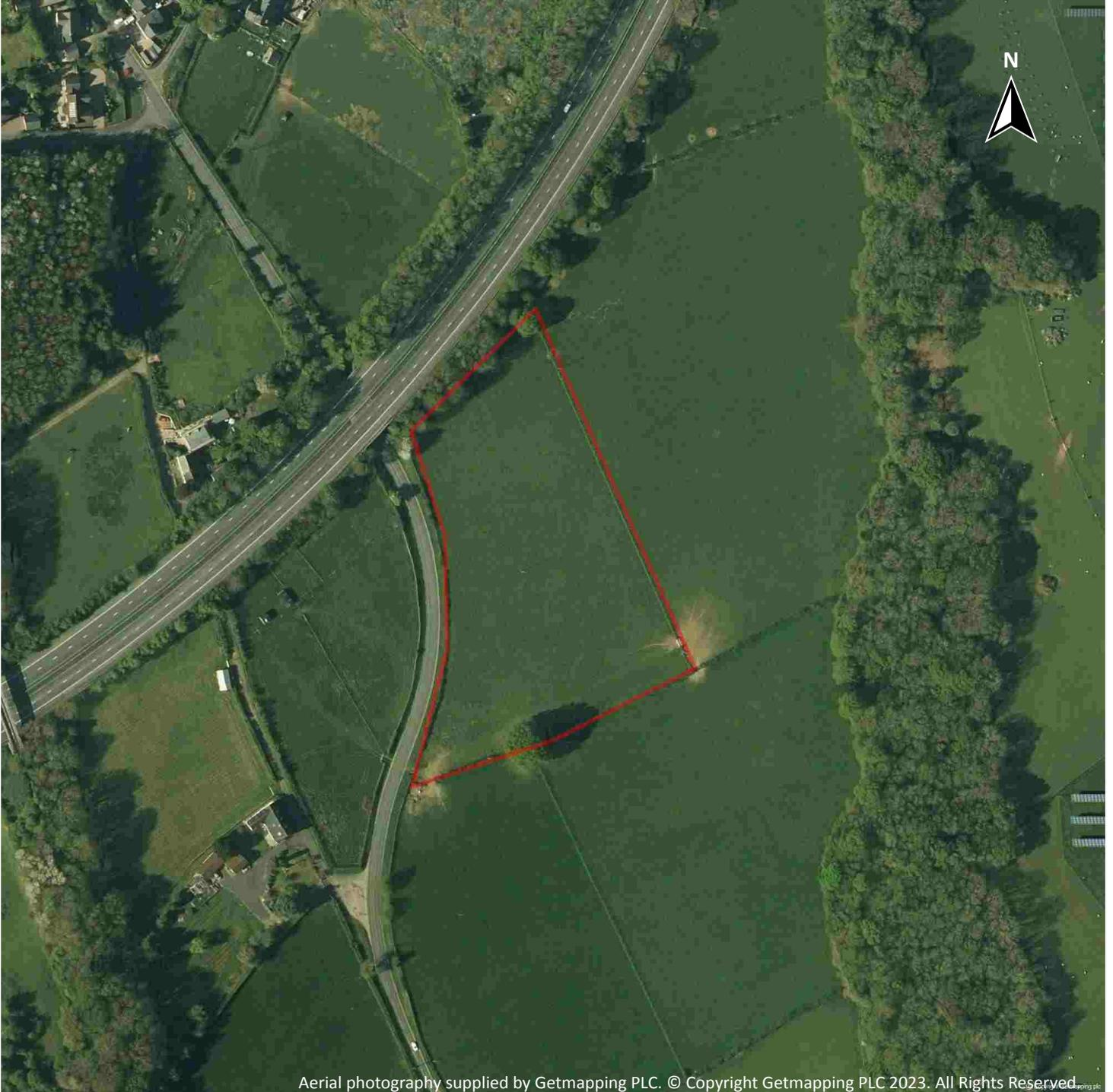

Capture Date: 14/04/2020

Site Area: 1.79ha



## Recent site history - 2017 aerial photograph



Capture Date: 26/05/2017

Site Area: 1.79ha



## Recent site history - 2009 aerial photograph

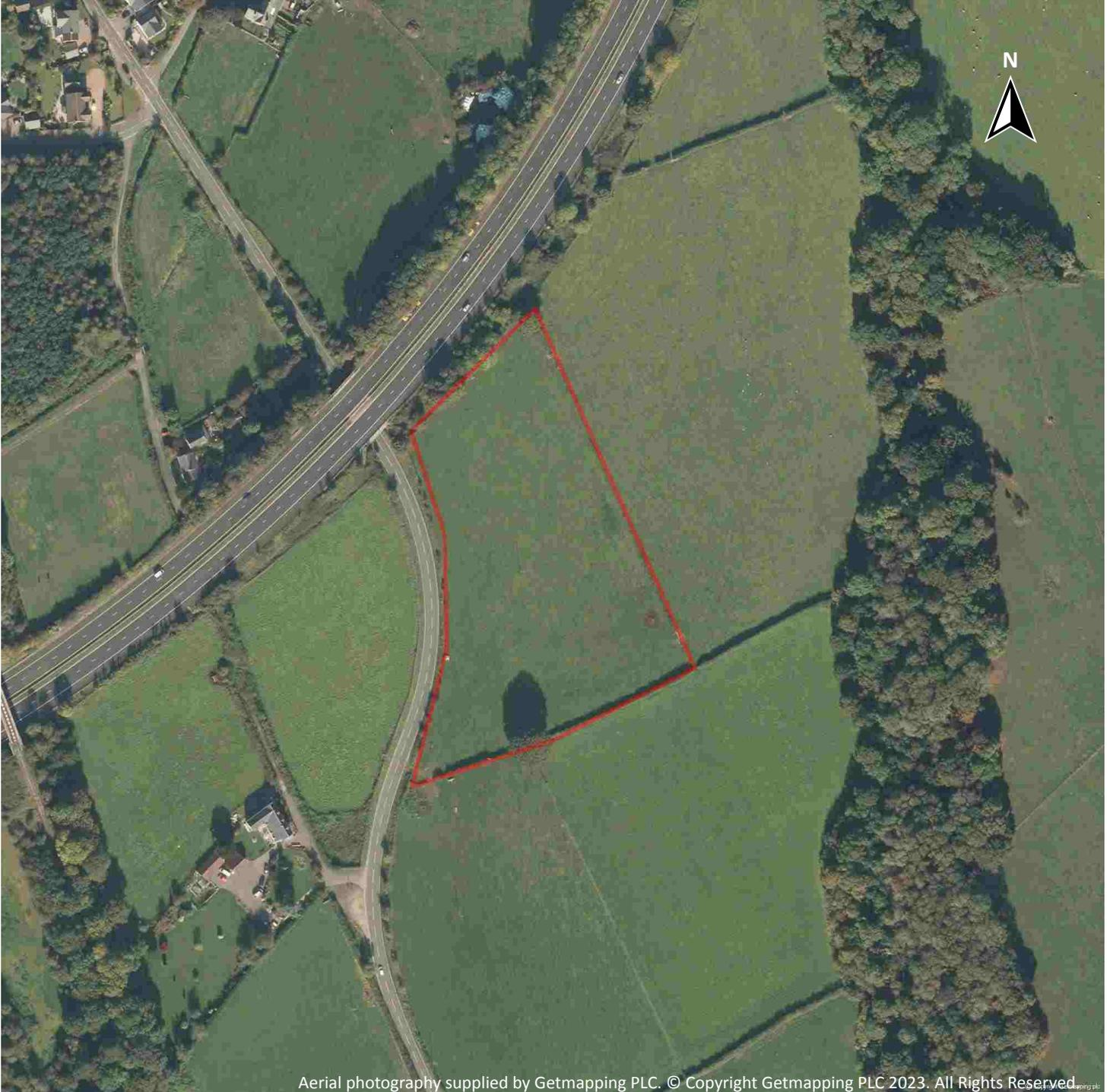

Capture Date: 14/10/2009

Site Area: 1.79ha



## Recent site history - 2008 aerial photograph



Capture Date: 27/07/2008

Site Area: 1.79ha



## Recent site history - 2000 aerial photograph

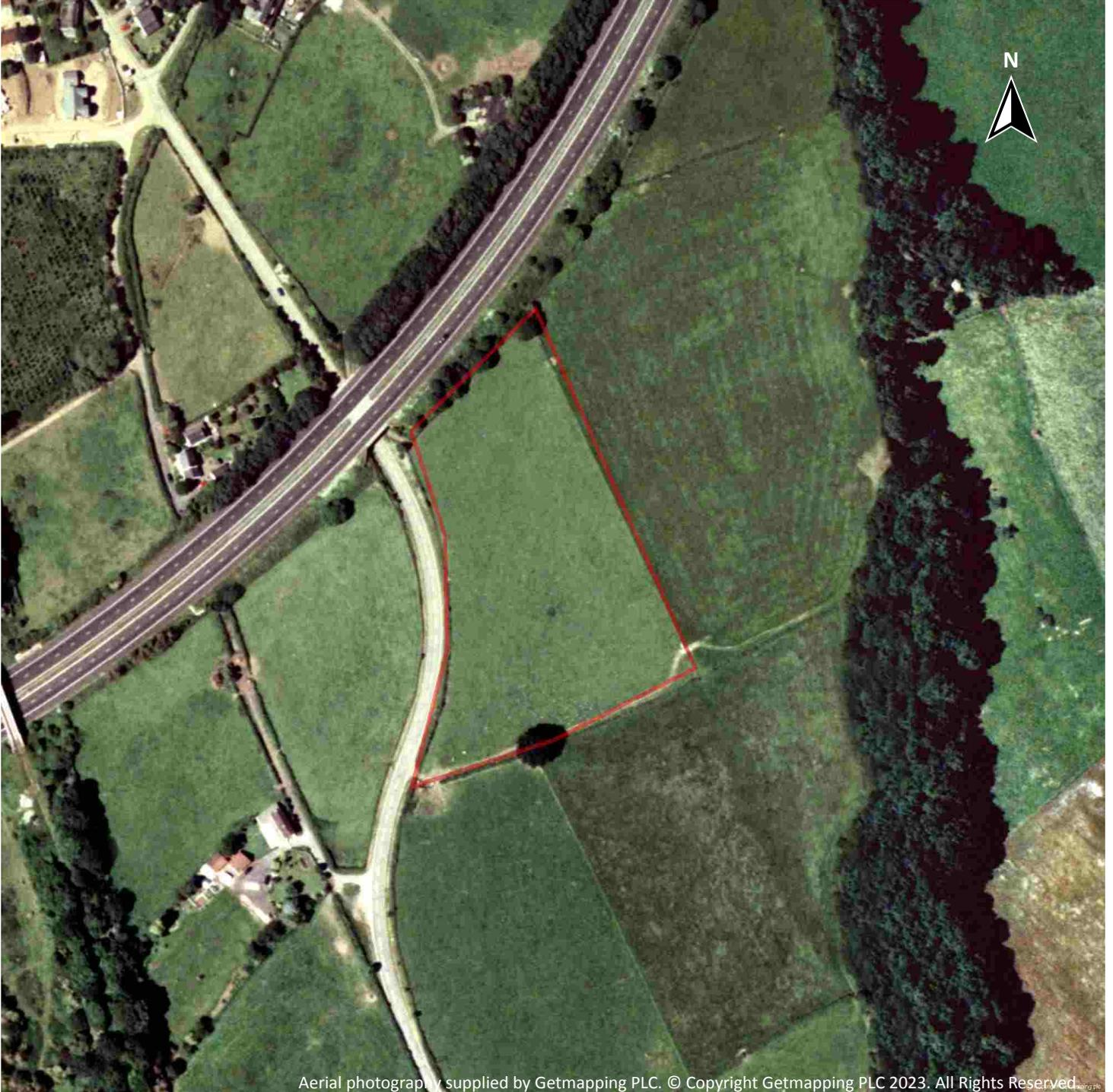

Capture Date: 21/07/2000

Site Area: 1.79ha



## OS MasterMap site plan

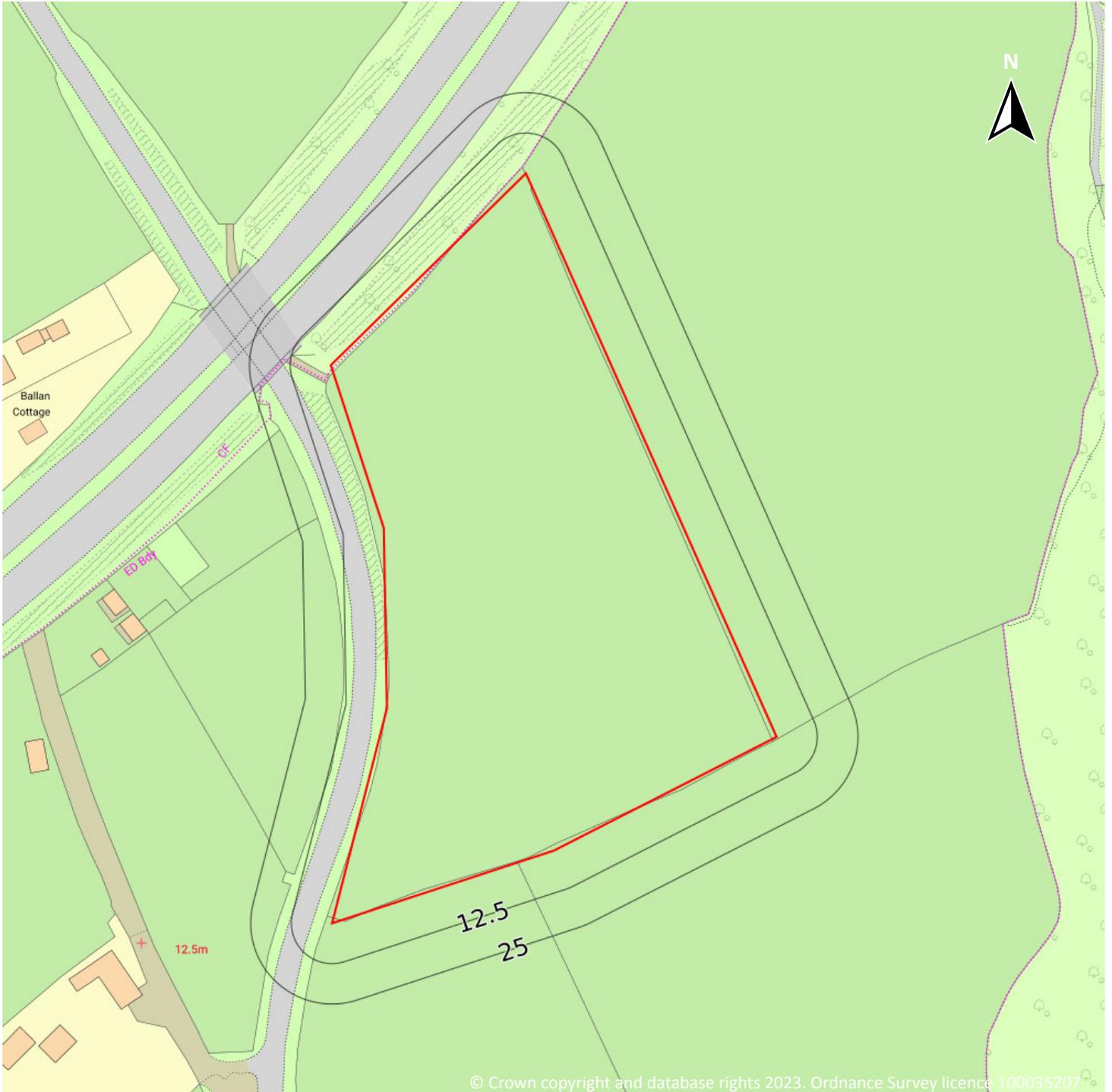

© Crown copyright and database rights 2023. Ordnance Survey licence 100035207

Site Area: 1.79ha



# 1 Past land use

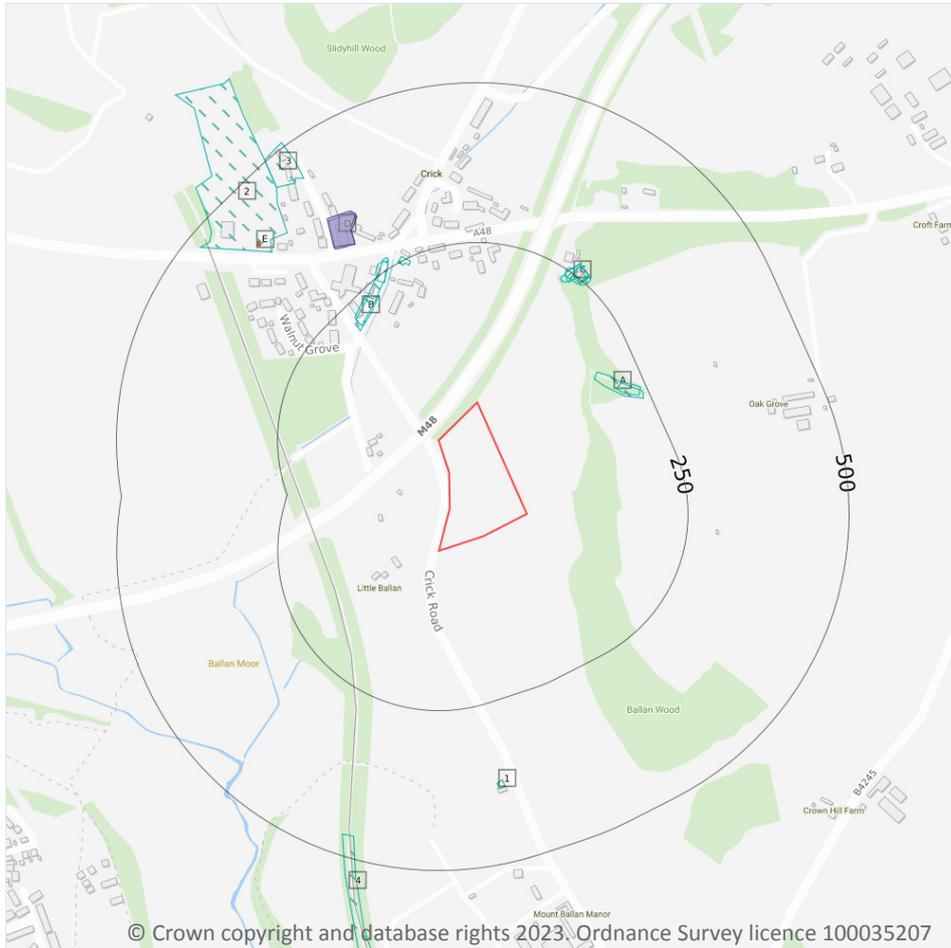

- Site Outline
- Search buffers in metres (m)
- Historical industrial land uses
- Historical energy features
- Historical garages

## 1.1 Historical industrial land uses

**Records within 500m** **14**

Potentially contaminative land use features digitised from historical Ordnance Survey mapping at 1:10,000 and 1:10,560 scale, intelligently grouped into contiguous features. To prevent misrepresentation of the size of historical features at any given time, features are only grouped if they have similar geometries within immediately preceding or succeeding map editions. See section 2 for a breakdown of grouping if required. Grouped and the original un-grouped features can be cross-referenced across sections 1 and 2 using the 'Group ID'.

Features are displayed on the Past land use map on [page 15 >](#)

ID	Location	Land use	Dates present	Group ID
A	181m NE	Cuttings	1919 - 1949	1229590



ID	Location	Land use	Dates present	Group ID
A	206m NE	Cuttings	1949	1215866
B	207m NW	Unspecified Pit	1919 - 1949	1220993
B	211m NW	Unspecified Pit	1949	1232447
C	230m NE	Unspecified Old Quarry	1902	1241874
C	236m NE	Unspecified Old Quarry	1919 - 1949	1202477
B	236m NW	Unspecified Pit	1919 - 1949	1230572
B	239m N	Smithy	1919	1188923
C	240m NE	Unspecified Old Quarry	1967 - 1968	1200803
C	240m NE	Unspecified Old Quarry	1949	1239385
1	371m S	Telephone Exchange	1969 - 1983	1212686
2	391m NW	Unspecified Depot	1967 - 1968	1256686
3	442m NW	Unspecified Works	1967 - 1968	1219132
4	466m S	Cuttings	1983	1158509

*This data is sourced from Ordnance Survey / Groundsure.*

## 1.2 Historical tanks

<b>Records within 500m</b>	<b>0</b>
----------------------------	----------

Tank features digitised from historical Ordnance Survey mapping at high-detail 1:1,250 and 1:2,500 scale, intelligently grouped into contiguous features. To prevent misrepresentation of the size of historical features at any given time, features are only grouped if they have similar geometries within immediately preceding or succeeding map editions. See section 2 for a breakdown of grouping if required. Grouped and the original ungrouped features can be cross-referenced across sections 1 and 2 using the 'Group ID'.

*This data is sourced from Ordnance Survey / Groundsure.*

## 1.3 Historical energy features

<b>Records within 500m</b>	<b>2</b>
----------------------------	----------

Energy features digitised from historical Ordnance Survey mapping at high-detail 1:1,250 and 1:2,500 scale, intelligently grouped into contiguous features. To prevent misrepresentation of the size of historical features at any given time, features are only grouped if they have similar geometries within immediately preceding or succeeding map editions. See section 2 for a breakdown of grouping if required. Grouped and the original ungrouped features can be cross-referenced across sections 1 and 2 using the 'Group ID'.



Features are displayed on the Past land use map on [page 15 >](#)

ID	Location	Land use	Dates present	Group ID
E	411m NW	Electricity Substation	-	96473
E	414m NW	Electricity Substation	1998	97973

*This data is sourced from Ordnance Survey / Groundsure.*

## 1.4 Historical petrol stations

**Records within 500m**

**0**

Petrol stations digitised from historical Ordnance Survey mapping at high-detail 1:1,250 and 1:2,500 scale, intelligently grouped into contiguous features. To prevent misrepresentation of the size of historical features at any given time, features are only grouped if they have similar geometries within immediately preceding or succeeding map editions. See section 2 for a breakdown of grouping if required. Grouped and the original ungrouped features can be cross-referenced across sections 1 and 2 using the 'Group ID'.

*This data is sourced from Ordnance Survey / Groundsure.*

## 1.5 Historical garages

**Records within 500m**

**2**

Garages digitised from historical Ordnance Survey mapping at high-detail 1:1,250 and 1:2,500 scale, intelligently grouped into contiguous features. To prevent misrepresentation of the size of historical features at any given time, features are only grouped if they have similar geometries within immediately preceding or succeeding map editions. See section 2 for a breakdown of grouping if required. Grouped and the original ungrouped features can be cross-referenced across sections 1 and 2 using the 'Group ID'.

Features are displayed on the Past land use map on [page 15 >](#)

ID	Location	Land use	Dates present	Group ID
D	311m NW	Garage	1964 - 1967	35409
D	313m NW	Garage	1998	33628

*This data is sourced from Ordnance Survey / Groundsure.*

## 1.6 Historical military land

Records within 500m

0

Areas of military land digitised from multiple sources including the National Archives, local records, MOD records and verified other sources, intelligently grouped into contiguous features.

*This data is sourced from Ordnance Survey / Groundsure / other sources.*



## 2 Past land use - un-grouped

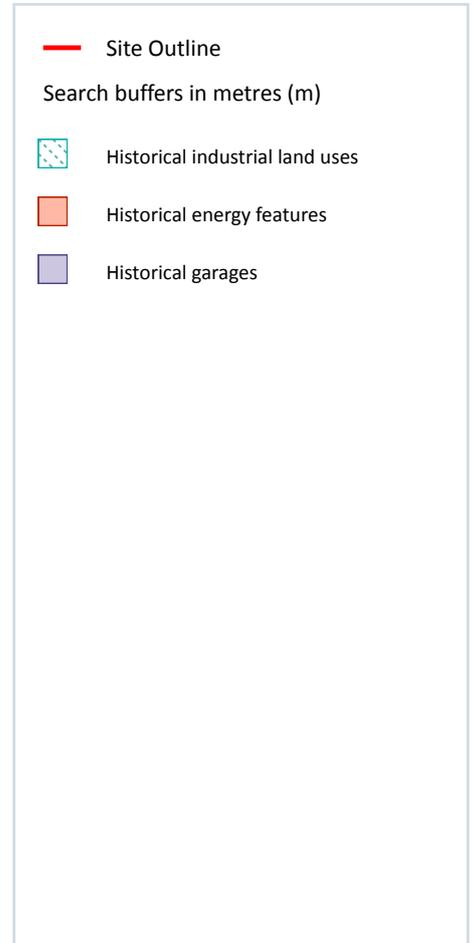
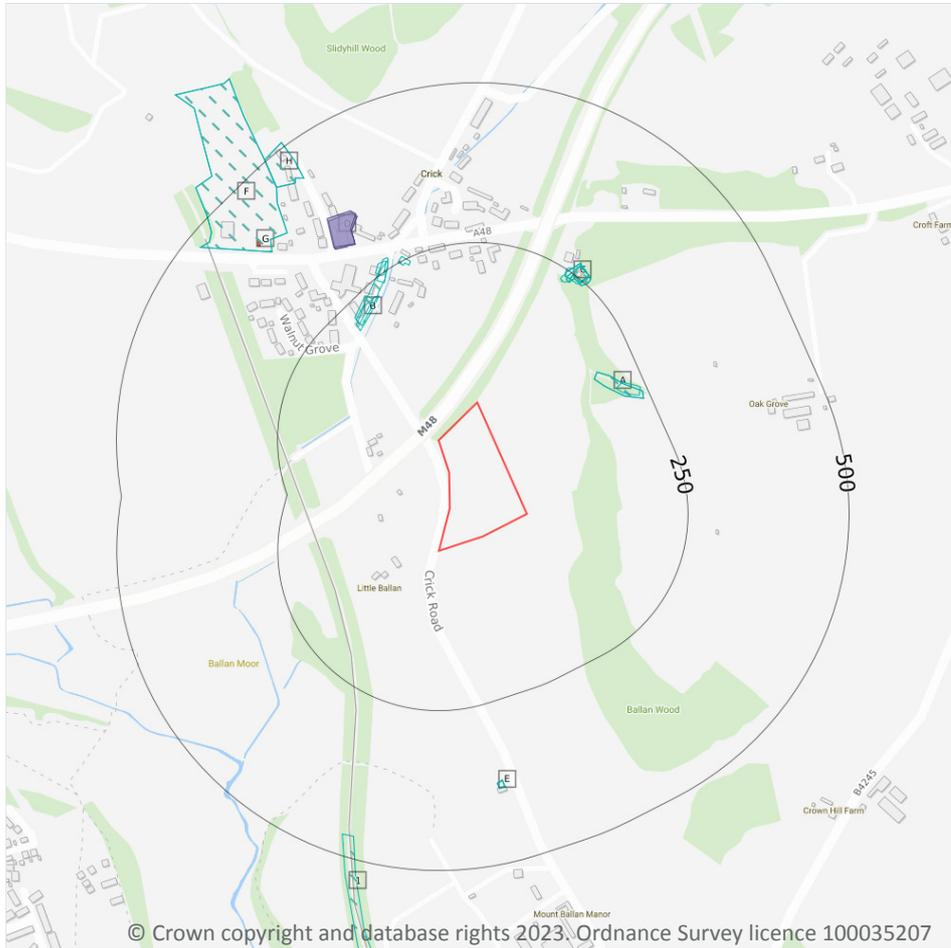

### 2.1 Historical industrial land uses

Records within 500m

22

Potentially contaminative land use features digitised from historical Ordnance Survey mapping at 1:10,000 and 10,560 scale. Any records shown are available intelligently grouped in section 1. Grouped and the original un-grouped features can be cross-referenced across sections 1 and 2 using the 'Group ID'.

Features are displayed on the Past land use - un-grouped map on [page 19](#) >

ID	Location	Land Use	Date	Group ID
A	181m NE	Cuttings	1949	1229590
A	181m NE	Cuttings	1919	1229590
A	206m NE	Cuttings	1949	1215866

ID	Location	Land Use	Date	Group ID
B	207m NW	Unspecified Pit	1919	1220993
B	211m NW	Unspecified Pit	1949	1232447
B	216m NW	Unspecified Pit	1949	1220993
C	230m NE	Unspecified Old Quarry	1902	1241874
C	236m NE	Unspecified Old Quarry	1949	1202477
C	236m NE	Unspecified Old Quarry	1919	1202477
B	236m NW	Unspecified Pit	1919	1230572
B	239m N	Smithy	1919	1188923
C	240m NE	Unspecified Old Quarry	1967	1200803
C	240m NE	Unspecified Old Quarry	1968	1200803
C	240m NE	Unspecified Old Quarry	1949	1239385
B	247m NW	Unspecified Pit	1949	1230572
E	371m S	Telephone Exchange	1983	1212686
E	373m S	Telephone Exchange	1969	1212686
F	391m NW	Unspecified Depot	1967	1256686
F	391m NW	Unspecified Depot	1968	1256686
H	442m NW	Unspecified Works	1967	1219132
H	442m NW	Unspecified Works	1968	1219132
1	466m S	Cuttings	1983	1158509

*This data is sourced from Ordnance Survey / Groundsure.*

## 2.2 Historical tanks

**Records within 500m**

**0**

Tank features digitised from historical Ordnance Survey mapping at high-detail 1:1,250 and 1:2,500 scale. Any records shown are available intelligently grouped in section 1. Grouped and the original un-grouped features can be cross-referenced across sections 1 and 2 using the 'Group ID'.

*This data is sourced from Ordnance Survey / Groundsure.*



## 2.3 Historical energy features

**Records within 500m**

**2**

Energy features digitised from historical Ordnance Survey mapping at high-detail 1:1,250 and 1:2,500 scale. Any records shown are available intelligently grouped in section 1. Grouped and the original un-grouped features can be cross-referenced across sections 1 and 2 using the 'Group ID'.

Features are displayed on the Past land use - un-grouped map on [page 19 >](#)

ID	Location	Land Use	Date	Group ID
G	411m NW	Electricity Substation	-	96473
G	414m NW	Electricity Substation	1998	97973

*This data is sourced from Ordnance Survey / Groundsure.*

## 2.4 Historical petrol stations

**Records within 500m**

**0**

Petrol stations digitised from historical Ordnance Survey mapping at high-detail 1:1,250 and 1:2,500 scale. Any records shown are available intelligently grouped in section 1. Grouped and the original un-grouped features can be cross-referenced across sections 1 and 2 using the 'Group ID'.

*This data is sourced from Ordnance Survey / Groundsure.*

## 2.5 Historical garages

**Records within 500m**

**3**

Garages digitised from historical Ordnance Survey mapping at high-detail 1:1,250 and 1:2,500 scale. Any records shown are available intelligently grouped in section 1. Grouped and the original un-grouped features can be cross-referenced across sections 1 and 2 using the 'Group ID'.

Features are displayed on the Past land use - un-grouped map on [page 19 >](#)

ID	Location	Land Use	Date	Group ID
D	311m NW	Garage	1967	35409
D	311m NW	Garage	1964	35409
D	313m NW	Garage	1998	33628

*This data is sourced from Ordnance Survey / Groundsure.*

### 3 Waste and landfill

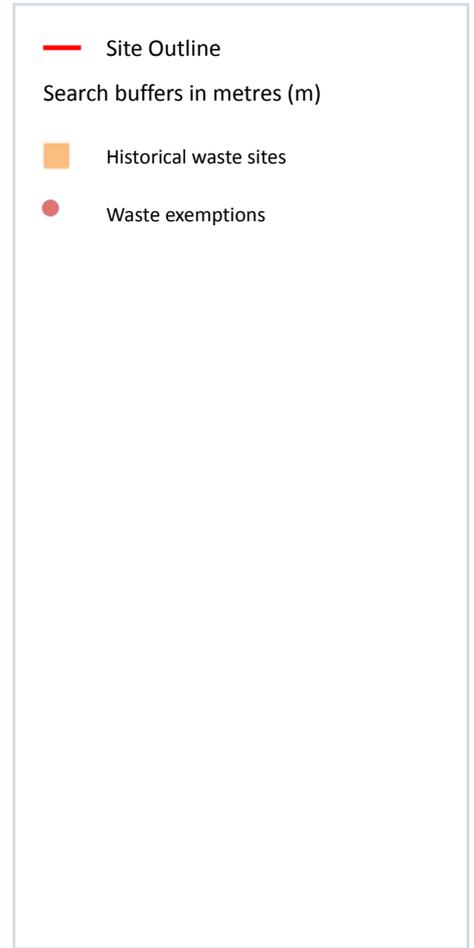
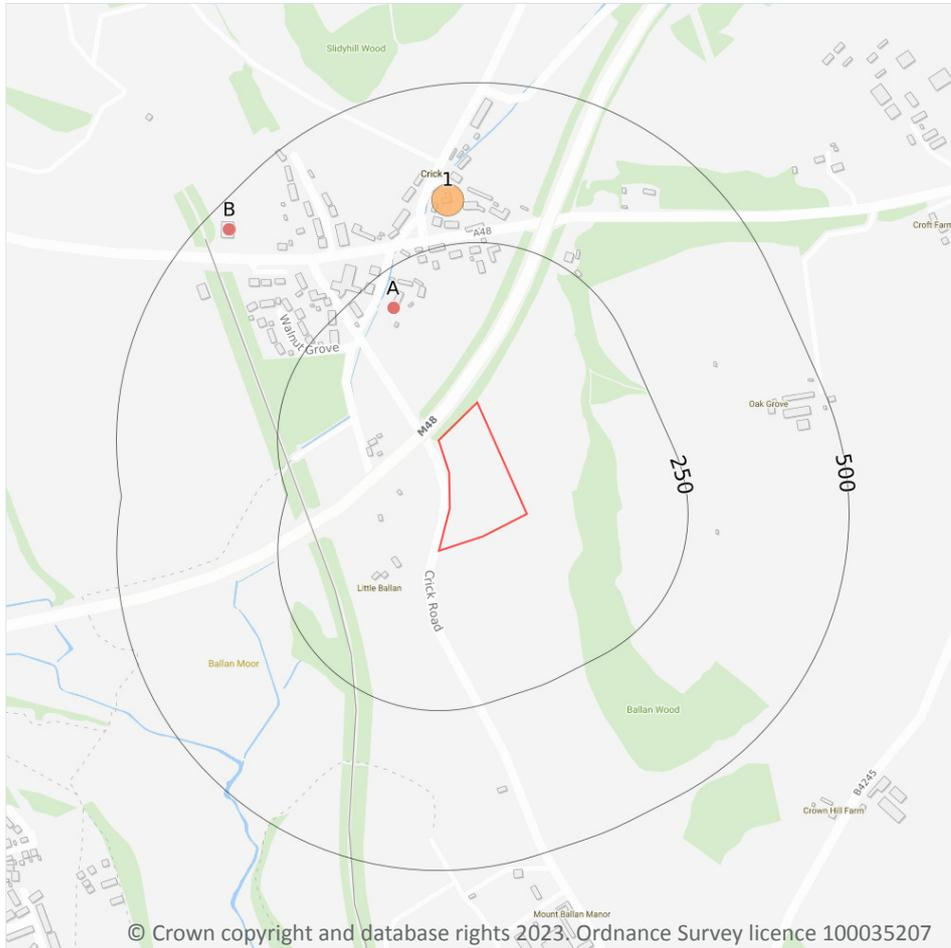

#### 3.1 Active or recent landfill

Records within 500m

0

Active or recently closed landfill sites under Environment Agency/Natural Resources Wales regulation.

*This data is sourced from the Environment Agency and Natural Resources Wales.*

#### 3.2 Historical landfill (BGS records)

Records within 500m

0

Landfill sites identified on a survey carried out on behalf of the DoE in 1973. These sites may have been closed or operational at this time.

*This data is sourced from the British Geological Survey.*

### 3.3 Historical landfill (LA/mapping records)

Records within 500m

0

Landfill sites identified from Local Authority records and high detail historical mapping.

*This data is sourced from the Ordnance Survey/Groundsure and Local Authority records.*

### 3.4 Historical landfill (EA/NRW records)

Records within 500m

0

Known historical (closed) landfill sites (e.g. sites where there is no PPC permit or waste management licence currently in force). This includes sites that existed before the waste licensing regime and sites that have been licensed in the past but where a licence has been revoked, ceased to exist or surrendered and a certificate of completion has been issued.

*This data is sourced from the Environment Agency and Natural Resources Wales.*

### 3.5 Historical waste sites

Records within 500m

1

Waste site records derived from Local Authority planning records and high detail historical mapping.

Features are displayed on the Waste and landfill map on [page 22 >](#)

ID	Location	Address	Further Details	Date
1	294m N	Site Address: The Folley, Manor Farm, Crick, Caldicot, Gwent, NP26 5BR	Type of Site: Waste Transfer Station Planning application reference: DC/2015/01013 Description: Scheme comprises to utilise the area of land, currently used for the processing of on-site material, as a waste transfer station, this station will handle the screening, sorting, crushing and grading of material brought on to site, the product of these processes will be sold on. Data source: Historic Planning Application Data Type: Point	-

*This data is sourced from Ordnance Survey/Groundsure and Local Authority records.*

### 3.6 Licensed waste sites

Records within 500m

0

Active or recently closed waste sites under Environment Agency/Natural Resources Wales regulation.

*This data is sourced from the Environment Agency and Natural Resources Wales.*



### 3.7 Waste exemptions

Records within 500m

7

Activities involving the storage, treatment, use or disposal of waste that are exempt from needing a permit. Exemptions have specific limits and conditions that must be adhered to.

Features are displayed on the Waste and landfill map on [page 22 >](#)

ID	Location	Site	Reference	Category	Sub-Category	Description
A	196m NW	Monmouthshire County Council, Manor Farm Depot, Shirenewton Road, Crick, Monmouthshire, NP26 5UW	NRW-WME068594	Storing waste exemption	Not on a farm	Storage of waste in a secure place
A	196m NW	Monmouthshire County Council, Manor Farm Depot, Shirenewton Road, Crick, Monmouthshire, NP26 5UW	NRW-WME068594	Using waste exemption	Not on a farm	Use of waste in construction
A	196m NW	Monmouthshire County Council, Monmouthshire County council Highways Depot, Manor Farm, Shirenewton road, Crick, Caldicot, Sir Fynwy, NP265UW	NRW-WME033211	Using waste exemption	Not on a farm	Use of waste in construction
A	196m NW	Monmouthshire County Council, Monmouthshire County Council, Manor Farm Depot, Shirenewton Road, Crick, Monmouthshire, NP265UW	NRW-WME033964	Storing waste exemption	Not on a farm	Storage of waste in a secure place
A	196m NW	Monmouthshire County Council, Monmouthshire County Council, Manor Farm Depot, Shirenewton Road, Crick, Monmouthshire, NP265UW	NRW-WME033964	Using waste exemption	Not on a farm	Use of waste in construction
B	462m NW	Sir Robert McAlpine Ltd, Sir Robert McAlpine Ltd, Caerwent Workshops, Caerwent, Caldicot, NP265XH	NRW-WME017973	Disposing of waste exemption	Not on a farm	Burning waste in the open



ID	Location	Site	Reference	Category	Sub-Category	Description
B	463m NW	CAERWENT WORKSHOPS, CAERWENT, CALDICOT, NP26 5XH	WEX071043	Disposing of waste exemption	Not on a farm	Burning waste in the open

*This data is sourced from the Environment Agency and Natural Resources Wales.*



## 4 Current industrial land use

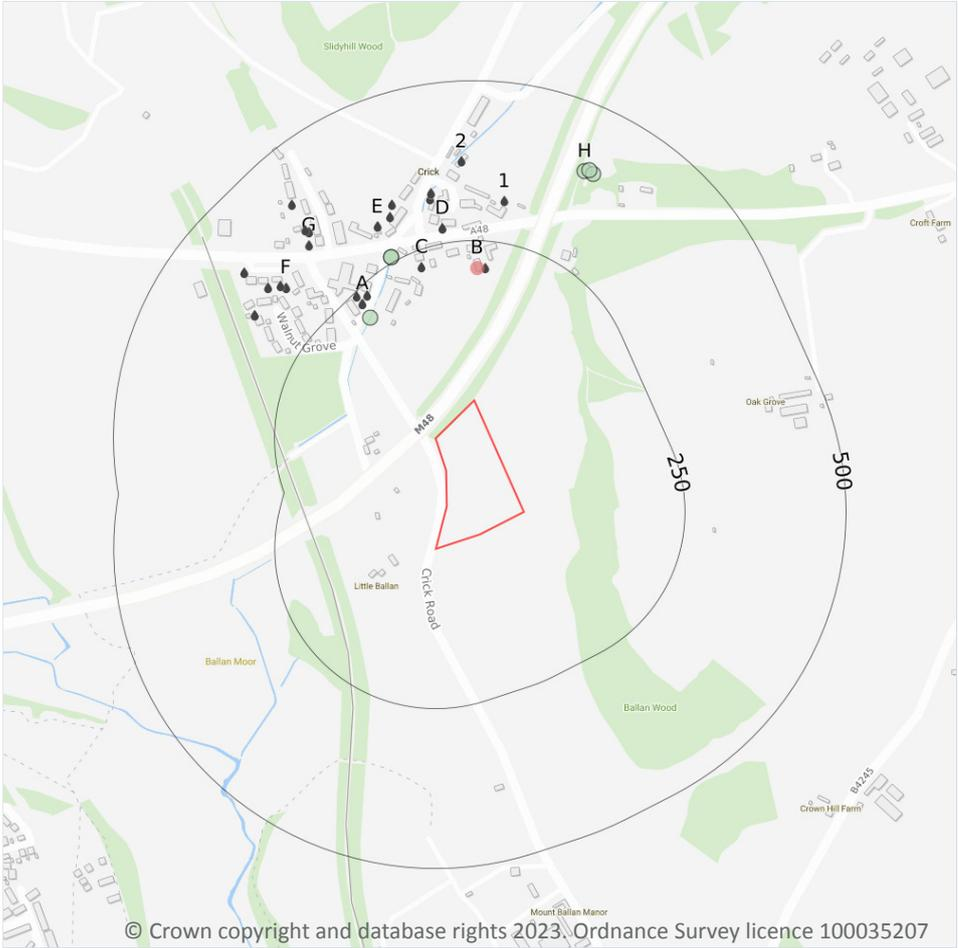

- Site Outline
- Search buffers in metres (m)
- Recent industrial land uses
- Licensed Discharges to controlled waters
- Pollution Incidents (EA/NRW)

### 4.1 Recent industrial land uses

**Records within 250m** **1**

Current potentially contaminative industrial sites.

Features are displayed on the Current industrial land use map on [page 26](#) >

ID	Location	Company	Address	Activity	Category
B	208m N	Celtic Fuel Oils Ltd	Lake House, -, Crick, Gwent, NP26 5UW	Fuel Distributors and Suppliers	Household, Office, Leisure and Garden

*This data is sourced from Ordnance Survey.*

## 4.2 Current or recent petrol stations

Records within 500m	0
---------------------	---

Open, closed, under development and obsolete petrol stations.

*This data is sourced from Experian.*

## 4.3 Electricity cables

Records within 500m	0
---------------------	---

High voltage underground electricity transmission cables.

*This data is sourced from National Grid.*

## 4.4 Gas pipelines

Records within 500m	0
---------------------	---

High pressure underground gas transmission pipelines.

*This data is sourced from National Grid.*

## 4.5 Sites determined as Contaminated Land

Records within 500m	0
---------------------	---

Contaminated Land Register of sites designated under Part 2a of the Environmental Protection Act 1990.

*This data is sourced from Local Authority records.*

## 4.6 Control of Major Accident Hazards (COMAH)

Records within 500m	0
---------------------	---

Control of Major Accident Hazards (COMAH) sites. This data includes upper and lower tier sites, and includes a historical archive of COMAH sites and Notification of Installations Handling Hazardous Substances (NIHHS) records.

*This data is sourced from the Health and Safety Executive.*

## 4.7 Regulated explosive sites

Records within 500m

0

Sites registered and licensed by the Health and Safety Executive under the Manufacture and Storage of Explosives Regulations 2005 (MSER). The last update to this data was in April 2011.

*This data is sourced from the Health and Safety Executive.*

## 4.8 Hazardous substance storage/usage

Records within 500m

0

Consents granted for a site to hold certain quantities of hazardous substances at or above defined limits in accordance with the Planning (Hazardous Substances) Regulations 2015.

*This data is sourced from Local Authority records.*

## 4.9 Historical licensed industrial activities (IPC)

Records within 500m

0

Integrated Pollution Control (IPC) records of substance releases to air, land and water. This data represents a historical archive as the IPC regime has been superseded.

*This data is sourced from the Environment Agency and Natural Resources Wales.*

## 4.10 Licensed industrial activities (Part A(1))

Records within 500m

0

Records of Part A(1) installations regulated under the Environmental Permitting (England and Wales) Regulations 2016 for the release of substances to the environment.

*This data is sourced from the Environment Agency and Natural Resources Wales.*

## 4.11 Licensed pollutant release (Part A(2)/B)

Records within 500m

0

Records of Part A(2) and Part B installations regulated under the Environmental Permitting (England and Wales) Regulations 2016 for the release of substances to the environment.

*This data is sourced from Local Authority records.*



## 4.12 Radioactive Substance Authorisations

Records within 500m

0

Records of the storage, use, accumulation and disposal of radioactive substances regulated under the Radioactive Substances Act 1993.

*This data is sourced from the Environment Agency and Natural Resources Wales.*

## 4.13 Licensed Discharges to controlled waters

Records within 500m

33

Discharges of treated or untreated effluent to controlled waters under the Water Resources Act 1991.

Features are displayed on the Current industrial land use map on [page 26 >](#)

ID	Location	Address	Details	
B	207m N	Lake House, Crick, Caldicot, NP26 5UW	Effluent Type: SEWAGE DISCHARGES - FINAL/TREATED EFFLUENT - NOT WATER COMPANY Permit Number: CB3593ZU Permit Version: 0 Receiving Water: Groundwater via infiltration system	Status: Effective Issue date: 09/06/2022 Effective Date: 09/06/2022 Revocation Date: -
C	224m N	SEPTIC TANKSERVING LLYSWEN, CRICK, CALDICOT, MONMOUTHSHIRE, NP26 5UW	Effluent Type: SEWAGE DISCHARGES - FINAL/TREATED EFFLUENT - NOT WATER COMPANY Permit Number: VP3423GP Permit Version: 0 Receiving Water: Groundwater via infiltration system	Status: Effective Issue date: 29/06/2012 Effective Date: 29/06/2012 Revocation Date: -
A	230m NW	SEPTIC TANK@ 1&2 CRICK PLACE, 1 & 2 CRICK PLACE, CALDICOT, MONMOUTHSHIRE, NP26 5UW	Effluent Type: SEWAGE DISCHARGES - FINAL/TREATED EFFLUENT - NOT WATER COMPANY Permit Number: XB3438AL Permit Version: 0 Receiving Water: Groundwater via infiltration system	Status: Effective Issue date: 25/04/2013 Effective Date: 25/04/2013 Revocation Date: -
A	230m NW	SEPTIC TANK@ 1&2 CRICK PLACE, 1 & 2 CRICK PLACE, CALDICOT, MONMOUTHSHIRE, NP26 5UW	Effluent Type: SEWAGE DISCHARGES - FINAL/TREATED EFFLUENT - NOT WATER COMPANY Permit Number: EPRXB3438AL Permit Version: 1 Receiving Water: GROUNDWATER	Status: NEW ISSUED UNDER EPR 2010 Issue date: 25/04/2013 Effective Date: 25/04/2013 Revocation Date: -



ID	Location	Address	Details	
A	233m NW	Kites Nest, Crick, Caldicot, NP26 5UW	Effluent Type: SEWAGE DISCHARGES - FINAL/TREATED EFFLUENT - NOT WATER COMPANY Permit Number: CB3797ZW Permit Version: 0 Receiving Water: Groundwater via infiltration system	Status: Effective Issue date: 16/02/2023 Effective Date: 16/02/2023 Revocation Date: -
A	244m NW	CRICK HOUSE NURSING HOME, CRICK HOUSE NURSING HOME, Crick, Caldicot, NP26 5UW	Effluent Type: SEWAGE DISCHARGES - FINAL/TREATED EFFLUENT - NOT WATER COMPANY Permit Number: AN0216101 Permit Version: 0 Receiving Water: TRIB OF NEDERN BROOK	Status: Effective Issue date: 03/10/2023 Effective Date: 03/10/2023 Revocation Date: -
D	274m N	ST @ MANOR CROFT, MANOR FARM, CRICK, CALDICOT, MONMOUTHSHIRE, NP26 5UW	Effluent Type: SEWAGE DISCHARGES - FINAL/TREATED EFFLUENT - NOT WATER COMPANY Permit Number: XP3826XT Permit Version: 0 Receiving Water: Groundwater via infiltration system	Status: Effective Issue date: 31/10/2012 Effective Date: 31/10/2012 Revocation Date: -
D	274m N	ST @ MANOR CROFT, MANOR FARM, CRICK, CALDICOT, MONMOUTHSHIRE, NP26 5UW	Effluent Type: SEWAGE DISCHARGES - FINAL/TREATED EFFLUENT - NOT WATER COMPANY Permit Number: EPRXP3826XT Permit Version: 1 Receiving Water: GROUNDWATER VIA SOAKAWAY	Status: NEW ISSUED UNDER EPR 2010 Issue date: 31/10/2012 Effective Date: 31/10/2012 Revocation Date: -
E	310m N	ST DONATS, CRICK, CALDICOT, GWENT, WALES, NP26 5UW	Effluent Type: SEWAGE DISCHARGES - FINAL/TREATED EFFLUENT - NOT WATER COMPANY Permit Number: SP3327XD Permit Version: 0 Receiving Water: Groundwater via infiltration system	Status: Effective Issue date: 29/03/2012 Effective Date: 29/03/2012 Revocation Date: -
E	310m N	ST DONATS, CRICK, CALDICOT, GWENT, WALES, NP26 5UW	Effluent Type: SEWAGE DISCHARGES - FINAL/TREATED EFFLUENT - NOT WATER COMPANY Permit Number: EPRSP3327XD Permit Version: 1 Receiving Water: GROUNDWATER VIA AN INFILT SYS	Status: NEW ISSUED UNDER EPR 2010 Issue date: 29/03/2012 Effective Date: 29/03/2012 Revocation Date: -



ID	Location	Address	Details	
1	314m N	SEPTIC TANK @ CRICK MANOR, CRICK MANOR, CRICK, CALDICOT, GWENT, NP26 5XU	Effluent Type: SEWAGE DISCHARGES - FINAL/TREATED EFFLUENT - NOT WATER COMPANY Permit Number: WP3524XJ Permit Version: 0 Receiving Water: Groundwater via infiltration system	Status: Effective Issue date: 25/09/2012 Effective Date: 25/09/2012 Revocation Date: -
E	315m N	Holly House, Holly House, Crick, Caldicot, NP26 5UW	Effluent Type: SEWAGE DISCHARGES - FINAL/TREATED EFFLUENT - NOT WATER COMPANY Permit Number: CB3699FQ Permit Version: 0 Receiving Water: Groundwater via infiltration system	Status: Effective Issue date: 26/10/2022 Effective Date: 26/10/2022 Revocation Date: -
D	322m N	SEPTIC TANK @ MANOR HAVEN, MANOR FARM, CRICK, CALDICOT, MONMOUTHSHIRE, NP26 5BR	Effluent Type: SEWAGE DISCHARGES - FINAL/TREATED EFFLUENT - NOT WATER COMPANY Permit Number: WP3326XJ Permit Version: 0 Receiving Water: Groundwater via infiltration system	Status: Effective Issue date: 06/08/2012 Effective Date: 06/08/2012 Revocation Date: -
D	322m N	SEPTIC TANK @ MANOR HAVEN, MANOR FARM, CRICK, CALDICOT, MONMOUTHSHIRE, NP26 5BR	Effluent Type: SEWAGE DISCHARGES - FINAL/TREATED EFFLUENT - NOT WATER COMPANY Permit Number: EPRWP3326XJ Permit Version: 1 Receiving Water: GROUNDWATER	Status: NEW ISSUED UNDER EPR 2010 Issue date: 06/08/2012 Effective Date: 06/08/2012 Revocation Date: -
E	331m N	Benbrook, Crick, Caldicot, NP26 5UW	Effluent Type: SEWAGE DISCHARGES - FINAL/TREATED EFFLUENT - NOT WATER COMPANY Permit Number: CB3897FQ Permit Version: 0 Receiving Water: Groundwater via an infiltration system	Status: Effective Issue date: 20/06/2023 Effective Date: 20/06/2023 Revocation Date: -
D	331m N	SEPTIC TANK AT MANOR COURT, MANOR FARM, CRICK, CALDICOT, MONMOUTHSHIRE, NP26 5UW	Effluent Type: SEWAGE DISCHARGES - FINAL/TREATED EFFLUENT - NOT WATER COMPANY Permit Number: XP3120GN Permit Version: 0 Receiving Water: Groundwater via infiltration system	Status: Effective Issue date: 14/09/2012 Effective Date: 14/09/2012 Revocation Date: -





ID	Location	Address	Details	
D	331m N	SEPTIC TANK AT MANOR COURT, MANOR FARM, CRICK, CALDICOT, MONMOUTHSHIRE, NP26 5UW	Effluent Type: SEWAGE DISCHARGES - FINAL/TREATED EFFLUENT - NOT WATER COMPANY Permit Number: EPRXP3120GN Permit Version: 1 Receiving Water: GROUNDWATER	Status: NEW ISSUED UNDER EPR 2010 Issue date: 14/09/2012 Effective Date: 14/09/2012 Revocation Date: -
F	331m NW	SEPTIC TANK SERVING MELROSE, MELROSE, CRICK, CALDICOT, MONMOUTHSHIRE, NP26 5UW	Effluent Type: SEWAGE DISCHARGES - FINAL/TREATED EFFLUENT - NOT WATER COMPANY Permit Number: YP3823GF Permit Version: 0 Receiving Water: Groundwater via infiltration system	Status: Effective Issue date: 21/12/2012 Effective Date: 21/12/2012 Revocation Date: -
F	331m NW	SEPTIC TANK SERVING MELROSE, MELROSE, CRICK, CALDICOT, MONMOUTHSHIRE, NP26 5UW	Effluent Type: SEWAGE DISCHARGES - FINAL/TREATED EFFLUENT - NOT WATER COMPANY Permit Number: EPRYP3823GF Permit Version: 1 Receiving Water: GROUND	Status: NEW ISSUED UNDER EPR 2010 Issue date: 21/12/2012 Effective Date: 21/12/2012 Revocation Date: -
F	338m NW	NEWTON HOUSE, CRICK, CALDICOT, MONMOUTHSHIRE, NP26 5UW	Effluent Type: SEWAGE DISCHARGES - FINAL/TREATED EFFLUENT - NOT WATER COMPANY Permit Number: WP3225XA Permit Version: 0 Receiving Water: Groundwater via infiltration system	Status: Effective Issue date: 16/08/2012 Effective Date: 16/08/2012 Revocation Date: -
F	340m NW	LAND OFF CRICK ROAD, CRICK, NEAR CHEPSTOW, MONMOUTHSHIRE, NP26 5UX	Effluent Type: SEWAGE DISCHARGES - FINAL/TREATED EFFLUENT - NOT WATER COMPANY Permit Number: AN0292801 Permit Version: 0 Receiving Water: Groundwater via infiltration system	Status: Effective Issue date: 27/05/2011 Effective Date: 27/05/2011 Revocation Date: -
F	340m NW	LAND OFF CRICK ROAD, CRICK, NEAR CHEPSTOW, MONMOUTHSHIRE, NP26 5UX	Effluent Type: SEWAGE DISCHARGES - FINAL/TREATED EFFLUENT - NOT WATER COMPANY Permit Number: AN029280101 Permit Version: 1 Receiving Water: LAND	Status: NEW CONSENT (WRA 91, S88 & SCHED 10 AS AMENDED BY ENV ACT 1995) Issue date: 28/09/1999 Effective Date: 28/09/1999 Revocation Date: 26/05/2011
F	340m NW	LAND OFF CRICK ROAD, CRICK, NEAR CHEPSTOW, MONMOUTHSHIRE, NP26 5UX	Effluent Type: SEWAGE DISCHARGES - FINAL/TREATED EFFLUENT - NOT WATER COMPANY Permit Number: AN029280101 Permit Version: 2 Receiving Water: LAND	Status: NEW CONSENT (WRA 91, S88 & SCHED 10 AS AMENDED BY ENV ACT 1995) Issue date: 27/05/2011 Effective Date: 27/05/2011 Revocation Date: -



ID	Location	Address	Details	
F	351m NW	SEPTIC TANK AND INFILTRATION SYT. @, RUSSET HOUSE, CRICK, CALDICOT, MONMOUTHSHIRE, NP26 5UW	Effluent Type: SEWAGE DISCHARGES - FINAL/TREATED EFFLUENT - NOT WATER COMPANY Permit Number: ZB3893HV Permit Version: 0 Receiving Water: Groundwater via infiltration system	Status: Effective Issue date: 21/07/2021 Effective Date: 26/07/2021 Revocation Date: -
F	351m NW	SEPTIC TANK AND INFILTRATION SYT. @, RUSSET HOUSE, CRICK, CALDICOT, MONMOUTHSHIRE, NP26 5UW	Effluent Type: SEWAGE DISCHARGES - FINAL/TREATED EFFLUENT - NOT WATER COMPANY Permit Number: EPRZB3893HV Permit Version: 1 Receiving Water: GROUNDWATER	Status: NEW ISSUED UNDER EPR 2010 Issue date: 23/07/2014 Effective Date: 23/07/2014 Revocation Date: -
G	353m NW	Crick Lodge, Crick Lodge, Crick, Caldicot, NP26 5UW	Effluent Type: SEWAGE DISCHARGES - FINAL/TREATED EFFLUENT - NOT WATER COMPANY Permit Number: AB3199ZG Permit Version: 0 Receiving Water: Groundwater via infiltration system	Status: Effective Issue date: 02/11/2016 Effective Date: 08/11/2016 Revocation Date: -
G	368m NW	SEPTIC TANK AT PRIMROSE COTTAGE, OLD SHIRENEWTON ROAD, CRICK, CALDICOT, MONMOUTHSHIRE, NP26 5UW	Effluent Type: SEWAGE DISCHARGES - FINAL/TREATED EFFLUENT - NOT WATER COMPANY Permit Number: XP3223KS Permit Version: 0 Receiving Water: Groundwater via infiltration system	Status: Effective Issue date: 14/09/2012 Effective Date: 14/09/2012 Revocation Date: -
G	368m NW	SEPTIC TANK AT PRIMROSE COTTAGE, OLD SHIRENEWTON ROAD, CRICK, CALDICOT, MONMOUTHSHIRE, NP26 5UW	Effluent Type: SEWAGE DISCHARGES - FINAL/TREATED EFFLUENT - NOT WATER COMPANY Permit Number: EPRXP3223KS Permit Version: 1 Receiving Water: GROUNDWATER	Status: NEW ISSUED UNDER EPR 2010 Issue date: 14/09/2012 Effective Date: 14/09/2012 Revocation Date: -
2	374m N	HIGHWAY DIRECT WORKS MANOR FARM, HIGHWAY DIRECT WORKS, MANOR FARM DEPOT, CRICK NEAR CHEPSTOW, NP26 5UW	Effluent Type: SEWAGE DISCHARGES - FINAL/TREATED EFFLUENT - NOT WATER COMPANY Permit Number: AN0293201 Permit Version: 0 Receiving Water: TRIB OF NEDERN BROOK	Status: Effective Issue date: 29/10/1999 Effective Date: 29/10/1999 Revocation Date: -



ID	Location	Address	Details	
G	374m NW	Kylemore, Kylemore, Crick, Caldicot, NP26 5UW	Effluent Type: SEWAGE DISCHARGES - FINAL/TREATED EFFLUENT - NOT WATER COMPANY Permit Number: AB3391ZR Permit Version: 0 Receiving Water: Groundwater via infiltration system	Status: Effective Issue date: 15/12/2016 Effective Date: 15/12/2016 Revocation Date: -
F	394m NW	SEPTIC TANK @ BRAMLEY HOUSE, CRICK, NR. CALDICOTE, MONMOUTHSHIRE, -, NP26 5UW	Effluent Type: SEWAGE DISCHARGES - FINAL/TREATED EFFLUENT - NOT WATER COMPANY Permit Number: UP3625XP Permit Version: 0 Receiving Water: Groundwater via infiltration system	Status: Effective Issue date: 29/05/2012 Effective Date: 29/05/2012 Revocation Date: -
F	394m NW	SEPTIC TANK @ BRAMLEY HOUSE, CRICK, NR. CALDICOTE, MONMOUTHSHIRE, NP26 5UW	Effluent Type: SEWAGE DISCHARGES - FINAL/TREATED EFFLUENT - NOT WATER COMPANY Permit Number: EPRUP3625XP Permit Version: 1 Receiving Water: GW VIA INFILTRATION SYSTEM	Status: NEW ISSUED UNDER EPR 2010 Issue date: 29/05/2012 Effective Date: 29/05/2012 Revocation Date: -
G	417m NW	Woodley, Crick, Caldicot, NP26 5UW	Effluent Type: SEWAGE DISCHARGES - FINAL/TREATED EFFLUENT - NOT WATER COMPANY Permit Number: CB3899FL Permit Version: 0 Receiving Water: Groundwater via infiltration system	Status: Effective Issue date: 07/07/2023 Effective Date: 07/07/2023 Revocation Date: -

*This data is sourced from the Environment Agency and Natural Resources Wales.*

#### 4.14 Pollutant release to surface waters (Red List)

**Records within 500m**

**0**

Discharges of specified substances under the Environmental Protection (Prescribed Processes and Substances) Regulations 1991.

*This data is sourced from the Environment Agency and Natural Resources Wales.*



#### 4.15 Pollutant release to public sewer

Records within 500m

0

Discharges of Special Category Effluents to the public sewer.

*This data is sourced from the Environment Agency and Natural Resources Wales.*

#### 4.16 List 1 Dangerous Substances

Records within 500m

0

Discharges of substances identified on List I of European Directive E 2006/11/EC, and regulated under the Environmental Damage (Prevention and Remediation) Regulations 2015.

*This data is sourced from the Environment Agency and Natural Resources Wales.*

#### 4.17 List 2 Dangerous Substances

Records within 500m

0

Discharges of substances identified on List II of European Directive E 2006/11/EC, and regulated under the Environmental Damage (Prevention and Remediation) Regulations 2015.

*This data is sourced from the Environment Agency and Natural Resources Wales.*

#### 4.18 Pollution Incidents (EA/NRW)

Records within 500m

6

Records of substantiated pollution incidents. Since 2006 this data has only included category 1 (major) and 2 (significant) pollution incidents.

Features are displayed on the Current industrial land use map on [page 26 >](#)

ID	Location	Details	
A	205m NW	Incident Date: 28/07/2010 Incident Identification: 807149 Pollutant: Sewage Materials Pollutant Description: Grey Water	Water Impact: Category 2 (Significant) Land Impact: Category 4 (No Impact) Air Impact: Category 4 (No Impact)
C	258m N	Incident Date: 08/12/2016 Incident Identification: 1607308 Pollutant: Pollutant Not Identified Pollutant Description: Pollutant Not Identified	Water Impact: Category 3 (Minor) Land Impact: No Details Air Impact: No Details

ID	Location	Details	
C	258m N	Incident Date: 08/12/2016 Incident Identification: 1607308 Pollutant: - Pollutant Description: -	Water Impact: Category 3 (Minor) Land Impact: No Details Air Impact: No Details
H	397m N	Incident Date: 06/12/2013 Incident Identification: 1181757 Pollutant: Inert Materials and Wastes Pollutant Description: Construction and Demolition Materials and Wastes	Water Impact: - Land Impact: Category 4 (No Impact) Air Impact: Category 4 (No Impact)
H	399m N	Incident Date: 23/05/2014 Incident Identification: 1238394 Pollutant: Multiple Pollutants Pollutant Description: 2 Pollutants Including Soils and Clay	Water Impact: - Land Impact: Category 4 (No Impact) Air Impact: Category 4 (No Impact)
H	402m N	Incident Date: 12/06/2014 Incident Identification: 1244566 Pollutant: Inert Materials and Wastes Pollutant Description: Rocks and Gravel	Water Impact: - Land Impact: Category 4 (No Impact) Air Impact: Category 4 (No Impact)

*This data is sourced from the Environment Agency and Natural Resources Wales.*

#### 4.19 Pollution inventory substances

**Records within 500m**

**0**

The pollution inventory (substances) includes reporting on annual emissions of certain regulated substances to air, controlled waters and land. A reporting threshold for each substance is also included. Where emissions fall below the reporting threshold, no value will be given. The data is given for the most recent complete year available.

*This data is sourced from the Environment Agency and the Scottish Environment Protection Agency.*

#### 4.20 Pollution inventory waste transfers

**Records within 500m**

**0**

The pollution inventory (waste transfers) includes reporting on annual transfers and recovery/disposal of controlled wastes from a site. A reporting threshold for each waste type is also included. Where releases fall below the reporting threshold, no value will be given. The data is given for the most recent complete year available.

*This data is sourced from the Environment Agency and the Scottish Environment Protection Agency.*



## 4.21 Pollution inventory radioactive waste

Records within 500m

0

The pollution inventory (radioactive wastes) includes reporting on annual releases of radioactive substances from a site, including the means of release. Where releases fall below the reporting threshold, no value will be given. The data is given for the most recent complete year available.

*This data is sourced from the Environment Agency and the Scottish Environment Protection Agency.*



## 5 Hydrogeology - Superficial aquifer

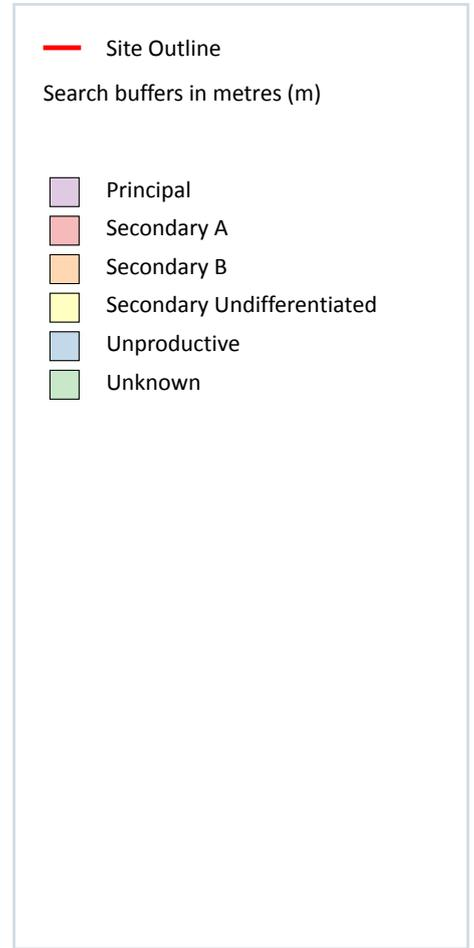
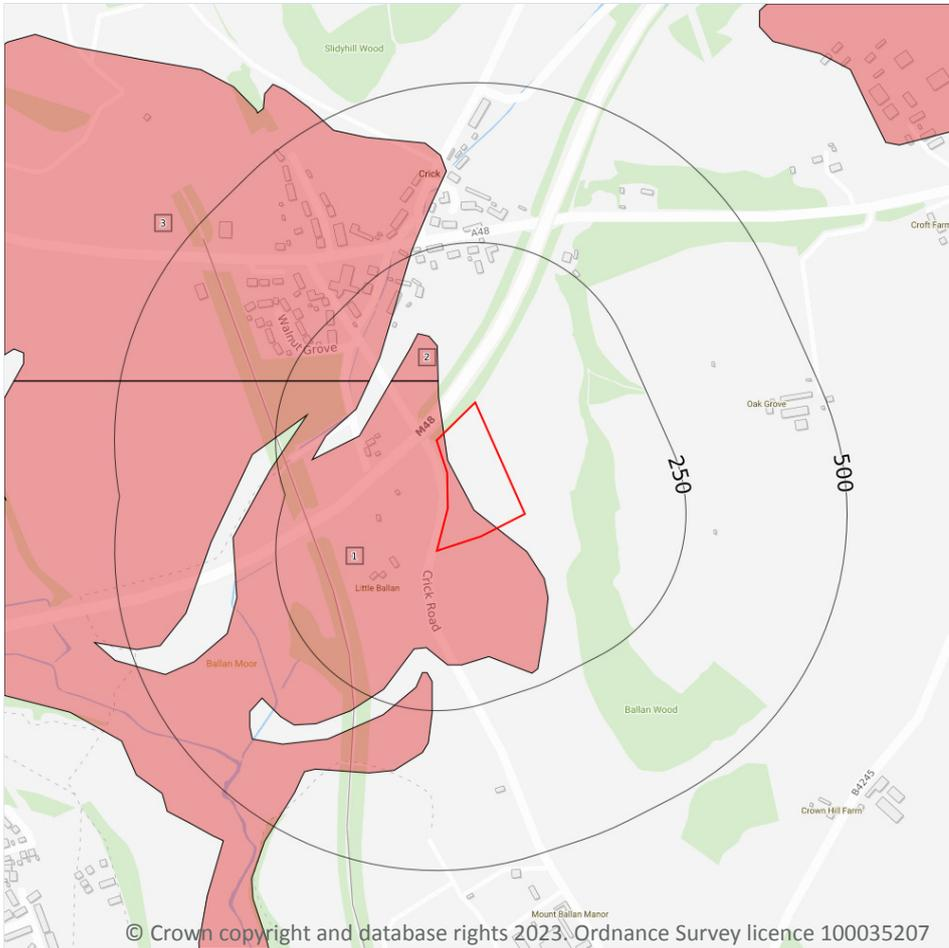

### 5.1 Superficial aquifer

Records within 500m

3

Aquifer status of groundwater held within superficial geology.

Features are displayed on the Hydrogeology map on [page 38 >](#)

ID	Location	Designation	Description
1	On site	Secondary A	Permeable layers capable of supporting water supplies at a local rather than strategic scale, and in some cases forming an important source of base flow to rivers. These are generally aquifers formerly classified as minor aquifers
2	64m N	Secondary A	Permeable layers capable of supporting water supplies at a local rather than strategic scale, and in some cases forming an important source of base flow to rivers. These are generally aquifers formerly classified as minor aquifers

ID	Location	Designation	Description
3	140m NW	Secondary A	Permeable layers capable of supporting water supplies at a local rather than strategic scale, and in some cases forming an important source of base flow to rivers. These are generally aquifers formerly classified as minor aquifers

*This data is sourced from the British Geological Survey, the Environment Agency and Natural Resources Wales.*



## Bedrock aquifer

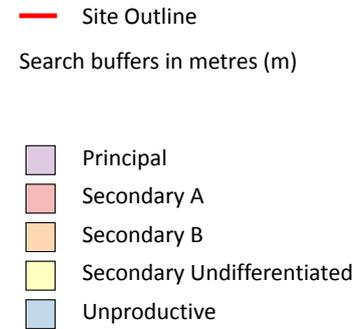
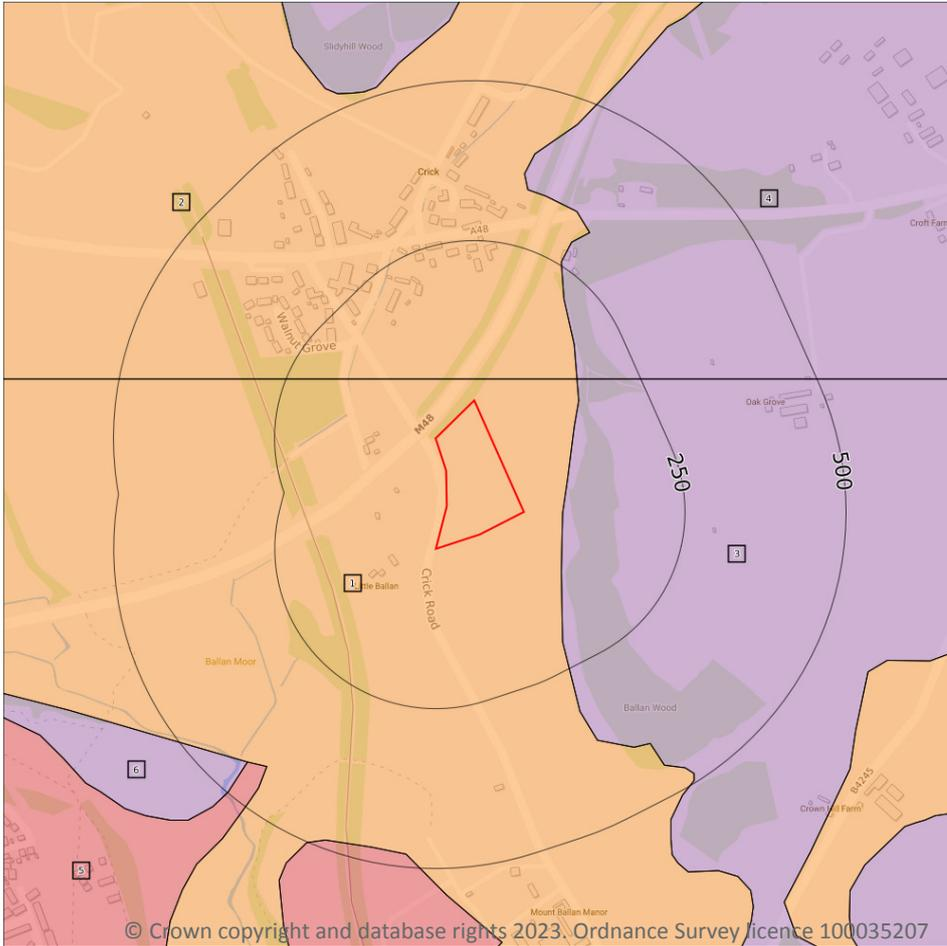

### 5.2 Bedrock aquifer

Records within 500m

6

Aquifer status of groundwater held within bedrock geology.

Features are displayed on the Bedrock aquifer map on [page 40 >](#)

ID	Location	Designation	Description
1	On site	Secondary B	<b>Predominantly lower permeability layers which may store/yield limited amounts of groundwater due to localised features such as fissures, thin permeable horizons and weathering. These are generally the water-bearing parts of the former non-aquifers</b>
2	34m N	Secondary B	Predominantly lower permeability layers which may store/yield limited amounts of groundwater due to localised features such as fissures, thin permeable horizons and weathering. These are generally the water-bearing parts of the former non-aquifers

ID	Location	Designation	Description
3	60m E	Principal	Geology of high intergranular and/or fracture permeability, usually providing a high level of water storage and may support water supply/river base flow on a strategic scale. Generally principal aquifers were previously major aquifers
4	159m NE	Principal	Geology of high intergranular and/or fracture permeability, usually providing a high level of water storage and may support water supply/river base flow on a strategic scale. Generally principal aquifers were previously major aquifers
5	430m SW	Secondary A	Permeable layers capable of supporting water supplies at a local rather than strategic scale, and in some cases forming an important source of base flow to rivers. These are generally aquifers formerly classified as minor aquifers
6	443m SW	Principal	Geology of high intergranular and/or fracture permeability, usually providing a high level of water storage and may support water supply/river base flow on a strategic scale. Generally principal aquifers were previously major aquifers

*This data is sourced from the British Geological Survey, the Environment Agency and Natural Resources Wales.*

## Groundwater vulnerability

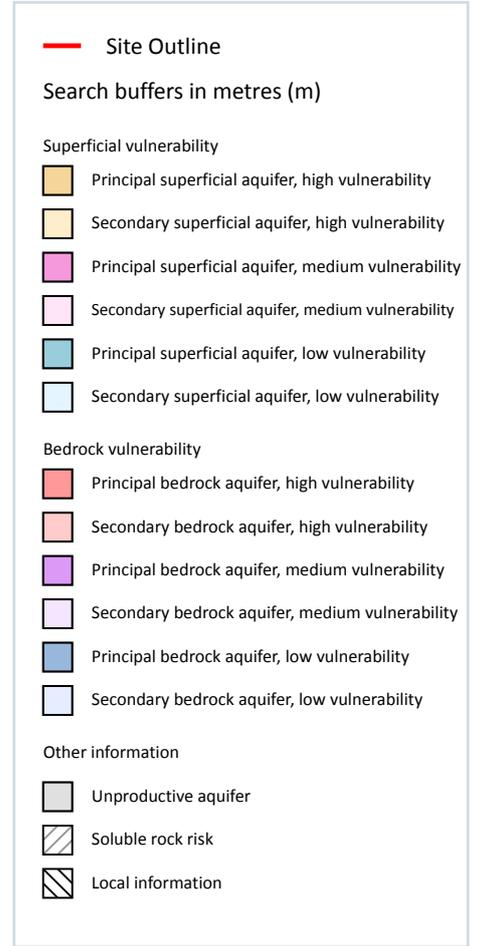
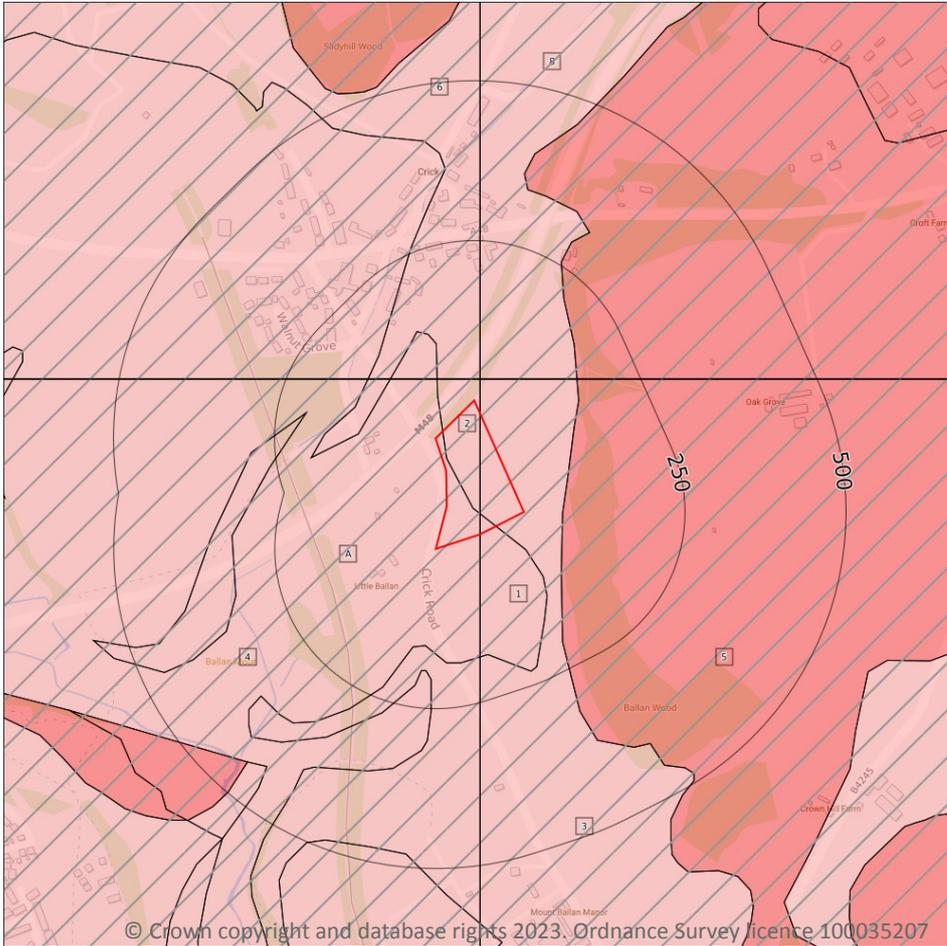

### 5.3 Groundwater vulnerability

Records within 50m

6

An assessment of the vulnerability of groundwater to a pollutant discharged at ground level based on the hydrological, geological, hydrogeological and soil properties within a one kilometre square grid. Groundwater vulnerability is described as High, Medium or Low as follows:

- High - Areas able to easily transmit pollution to groundwater. They are likely to be characterised by high leaching soils and the absence of low permeability superficial deposits.
- Medium - Intermediate between high and low vulnerability.
- Low - Areas that provide the greatest protection from pollution. They are likely to be characterised by low leaching soils and/or the presence of superficial deposits characterised by a low permeability.

Features are displayed on the Groundwater vulnerability map on [page 42 >](#)

ID	Location	Summary	Soil / surface	Superficial geology	Bedrock geology
1	On site	<b>Summary Classification:</b> Secondary bedrock aquifer - High Vulnerability <b>Combined classification:</b> Productive Bedrock Aquifer, Productive Superficial Aquifer	<b>Leaching class:</b> Intermediate <b>Infiltration value:</b> >70% <b>Dilution value:</b> 300-550mm/year	<b>Vulnerability:</b> Medium <b>Aquifer type:</b> Secondary <b>Thickness:</b> <3m <b>Patchiness value:</b> <90% <b>Recharge potential:</b> No Data	<b>Vulnerability:</b> High <b>Aquifer type:</b> Secondary <b>Flow mechanism:</b> Well connected fractures
2	On site	<b>Summary Classification:</b> Secondary bedrock aquifer - High Vulnerability <b>Combined classification:</b> Productive Bedrock Aquifer, No Superficial Aquifer	<b>Leaching class:</b> Intermediate <b>Infiltration value:</b> >70% <b>Dilution value:</b> 300-550mm/year	<b>Vulnerability:</b> - <b>Aquifer type:</b> - <b>Thickness:</b> <3m <b>Patchiness value:</b> <90% <b>Recharge potential:</b> High	<b>Vulnerability:</b> High <b>Aquifer type:</b> Secondary <b>Flow mechanism:</b> Well connected fractures
3	On site	<b>Summary Classification:</b> Secondary bedrock aquifer - High Vulnerability <b>Combined classification:</b> Productive Bedrock Aquifer, No Superficial Aquifer	<b>Leaching class:</b> Intermediate <b>Infiltration value:</b> >70% <b>Dilution value:</b> 300-550mm/year	<b>Vulnerability:</b> - <b>Aquifer type:</b> - <b>Thickness:</b> <3m <b>Patchiness value:</b> <90% <b>Recharge potential:</b> No Data	<b>Vulnerability:</b> High <b>Aquifer type:</b> Secondary <b>Flow mechanism:</b> Well connected fractures
A	On site	<b>Summary Classification:</b> Secondary bedrock aquifer - High Vulnerability <b>Combined classification:</b> Productive Bedrock Aquifer, Productive Superficial Aquifer	<b>Leaching class:</b> Intermediate <b>Infiltration value:</b> >70% <b>Dilution value:</b> 300-550mm/year	<b>Vulnerability:</b> Medium <b>Aquifer type:</b> Secondary <b>Thickness:</b> <3m <b>Patchiness value:</b> <90% <b>Recharge potential:</b> High	<b>Vulnerability:</b> High <b>Aquifer type:</b> Secondary <b>Flow mechanism:</b> Well connected fractures
6	33m N	<b>Summary Classification:</b> Secondary bedrock aquifer - High Vulnerability <b>Combined classification:</b> Productive Bedrock Aquifer, No Superficial Aquifer	<b>Leaching class:</b> Intermediate <b>Infiltration value:</b> >70% <b>Dilution value:</b> 300-550mm/year	<b>Vulnerability:</b> - <b>Aquifer type:</b> - <b>Thickness:</b> <3m <b>Patchiness value:</b> <90% <b>Recharge potential:</b> No Data	<b>Vulnerability:</b> High <b>Aquifer type:</b> Secondary <b>Flow mechanism:</b> Well connected fractures
8	34m N	<b>Summary Classification:</b> Secondary bedrock aquifer - High Vulnerability <b>Combined classification:</b> Productive Bedrock Aquifer, No Superficial Aquifer	<b>Leaching class:</b> Intermediate <b>Infiltration value:</b> >70% <b>Dilution value:</b> 300-550mm/year	<b>Vulnerability:</b> - <b>Aquifer type:</b> - <b>Thickness:</b> <3m <b>Patchiness value:</b> <90% <b>Recharge potential:</b> No Data	<b>Vulnerability:</b> High <b>Aquifer type:</b> Secondary <b>Flow mechanism:</b> Well connected fractures

*This data is sourced from the British Geological Survey, the Environment Agency and Natural Resources Wales.*



## 5.4 Groundwater vulnerability- soluble rock risk

<b>Records on site</b>	<b>2</b>
------------------------	----------

This dataset identifies areas where solution features that enable rapid movement of a pollutant may be present within a 1km grid square.

ID	Maximum soluble risk category	Percentage of grid square covered by maximum risk
4	<b>Very significant soluble rocks are likely to be present with a high possibility of localised subsidence or dissolution-related degradation of bedrock occurring naturally, especially in adverse conditions such as concentrated surface or subsurface water flow.</b>	<b>4.0%</b>
5	<b>Very significant soluble rocks are likely to be present with a high possibility of localised subsidence or dissolution-related degradation of bedrock occurring naturally, especially in adverse conditions such as concentrated surface or subsurface water flow.</b>	<b>10.0%</b>

*This data is sourced from the British Geological Survey and the Environment Agency.*

## 5.5 Groundwater vulnerability- local information

<b>Records on site</b>	<b>0</b>
------------------------	----------

This dataset identifies areas where additional local information affecting vulnerability is held by the Environment Agency. Further information can be obtained by contacting the Environment Agency local Area groundwater team through the Environment Agency National Customer Call Centre on 03798 506 506 or by email on [enquiries@environment-agency.gov.uk](mailto:enquiries@environment-agency.gov.uk) ↗.

*This data is sourced from the British Geological Survey and the Environment Agency.*

## Abstractions and Source Protection Zones

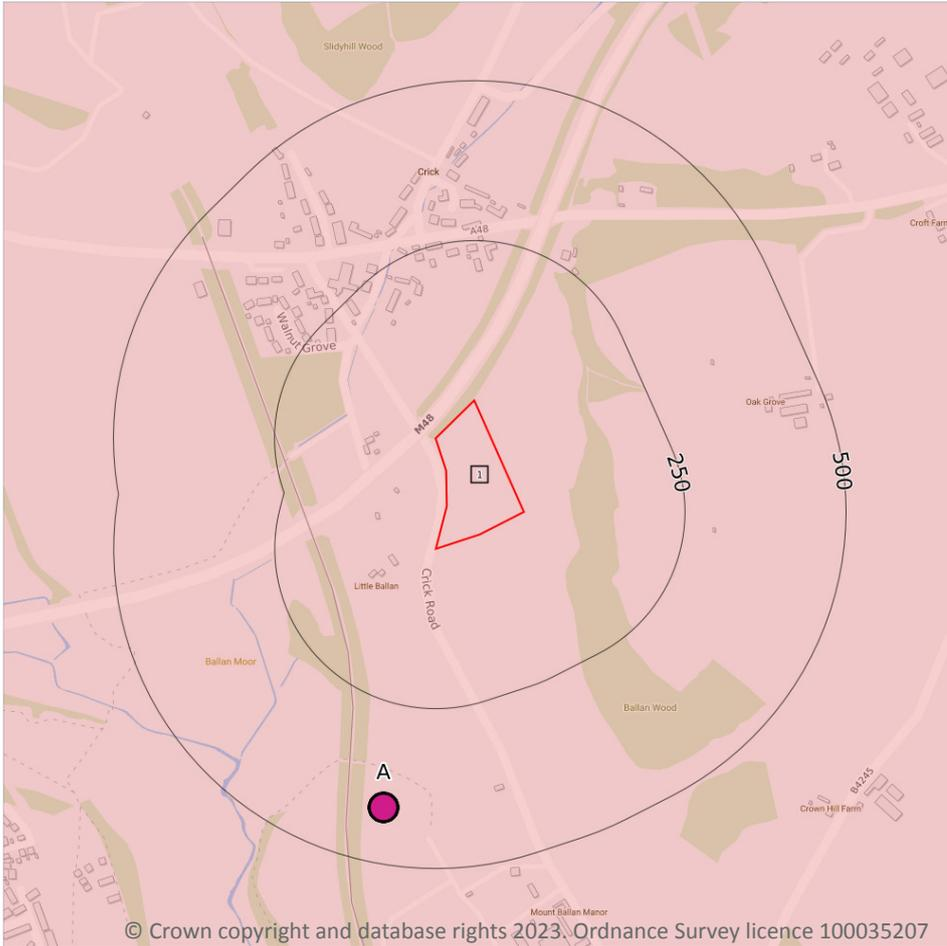

### 5.6 Groundwater abstractions

Records within 2000m

8

Licensed groundwater abstractions for sites extracting more than 20 cubic metres of water a day and includes active and historical records. The data may be for a single abstraction point, between two points (line data) or a larger area.

Features are displayed on the Abstractions and Source Protection Zones map on [page 45 >](#)

ID	Location	Details	
A	412m S	Status: Active Licence No: 20/56/72/0030 Details: Spray Irrigation - Direct - High Direct Source: Mercia Mudstone Group Point: - Data Type: Point Name: - Easting: 348850 Northing: 189330	Annual Volume (m <sup>3</sup> ): 10454 Max Daily Volume (m <sup>3</sup> ): - Original Application No: - Original Start Date: 13/11/2015 Expiry Date: - Issue No: - Version Start Date: - Version End Date: -
A	412m S	Status: Active Licence No: 20/56/72/0030 Details: General Farming & Domestic - Medium Direct Source: Mercia Mudstone Group Point: - Data Type: Point Name: - Easting: 348850 Northing: 189330	Annual Volume (m <sup>3</sup> ): 10454 Max Daily Volume (m <sup>3</sup> ): - Original Application No: - Original Start Date: 13/11/2015 Expiry Date: - Issue No: - Version Start Date: - Version End Date: -
A	412m S	Status: Active Licence No: 20/56/72/0030 Details: General Farming & Domestic - Medium Direct Source: Mercia Mudstone Group Point: - Data Type: Point Name: - Easting: 348850 Northing: 189330	Annual Volume (m <sup>3</sup> ): 4546 Max Daily Volume (m <sup>3</sup> ): - Original Application No: - Original Start Date: 13/11/2015 Expiry Date: - Issue No: - Version Start Date: - Version End Date: -
A	412m S	Status: Historical Licence No: 20/56/72/0030 Details: General Farming & Domestic Direct Source: EAW Groundwater Point: BOREHOLE AT MOUNT BALLAN MANOR Data Type: Point Name: Broome & Co Limited Easting: 348850 Northing: 189330	Annual Volume (m <sup>3</sup> ): 15000 Max Daily Volume (m <sup>3</sup> ): 261 Original Application No: - Original Start Date: 10/06/1987 Expiry Date: - Issue No: 102 Version Start Date: 13/11/2015 Version End Date: -
A	412m S	Status: Historical Licence No: 20/56/72/0030 Details: Spray Irrigation - Direct Direct Source: EAW Groundwater Point: BOREHOLE AT MOUNT BALLAN MANOR Data Type: Point Name: Broome & Co Limited Easting: 348850 Northing: 189330	Annual Volume (m <sup>3</sup> ): 15000 Max Daily Volume (m <sup>3</sup> ): 261 Original Application No: - Original Start Date: 10/06/1987 Expiry Date: - Issue No: 102 Version Start Date: 13/11/2015 Version End Date: -



ID	Location	Details	
A	412m S	Status: Active Licence No: 20/56/72/0030 Details: Spray Irrigation - Direct - High Direct Source: Mercia Mudstone Group Point: - Data Type: Point Name: - Easting: 348850 Northing: 189330	Annual Volume (m <sup>3</sup> ): 4546 Max Daily Volume (m <sup>3</sup> ): - Original Application No: - Original Start Date: 13/11/2015 Expiry Date: - Issue No: - Version Start Date: - Version End Date: -
-	753m S	Status: Historical Licence No: 20/56/72/0030 Details: General Farming & Domestic Direct Source: EAW Groundwater Point: BOREHOLE AT MOUNT BALLAN MANOR Data Type: Point Name: Broome & Co Ltd Easting: 349100 Northing: 189000	Annual Volume (m <sup>3</sup> ): 4546 Max Daily Volume (m <sup>3</sup> ): 218 Original Application No: - Original Start Date: 10/06/1987 Expiry Date: - Issue No: 101 Version Start Date: 02/12/2010 Version End Date: -
-	753m S	Status: Historical Licence No: 20/56/72/0030 Details: Spray Irrigation - Direct Direct Source: EAW Groundwater Point: BOREHOLE AT MOUNT BALLAN MANOR Data Type: Point Name: Broome & Co Ltd Easting: 349100 Northing: 189000	Annual Volume (m <sup>3</sup> ): 4546 Max Daily Volume (m <sup>3</sup> ): 218 Original Application No: - Original Start Date: 10/06/1987 Expiry Date: - Issue No: 101 Version Start Date: 02/12/2010 Version End Date: -

This data is sourced from the Environment Agency and Natural Resources Wales.

## 5.7 Surface water abstractions

Records within 2000m

3

Licensed surface water abstractions for sites extracting more than 20 cubic metres of water a day and includes active and historical records. The data may be for a single abstraction point, a stretch of watercourse or a larger area.

Features are displayed on the Abstractions and Source Protection Zones map on [page 45 >](#)





ID	Location	Details	
-	1158m S	Status: Historical Licence No: 20/56/72/0038 Details: Make-Up Or Top Up Water Direct Source: EAW Surface Water Point: NEDERN BROOK Data Type: Point Name: Monmouthshire County Council Easting: 348750 Northing: 188590	Annual Volume (m <sup>3</sup> ): 7800 Max Daily Volume (m <sup>3</sup> ): 100 Original Application No: - Original Start Date: 12/01/1995 Expiry Date: - Issue No: 101 Version Start Date: 21/07/2014 Version End Date: -
-	1158m S	Status: Historical Licence No: 20/56/72/0038 Details: Make-up or Top-up Water - High Direct Source: Nedern Brook Point: - Data Type: Point Name: - Easting: 348750 Northing: 188590	Annual Volume (m <sup>3</sup> ): 7800 Max Daily Volume (m <sup>3</sup> ): 480 Original Application No: - Original Start Date: 16/03/2018 Expiry Date: 31/03/2026 Issue No: - Version Start Date: - Version End Date: -
-	1158m S	Status: Active Licence No: 20/56/72/0038 Details: Make-up or Top-up Water - High Direct Source: Nedern Brook Point: - Data Type: Point Name: - Easting: 348750 Northing: 188590	Annual Volume (m <sup>3</sup> ): 7800 Max Daily Volume (m <sup>3</sup> ): 100 Original Application No: - Original Start Date: 16/03/2018 Expiry Date: - Issue No: - Version Start Date: - Version End Date: -

*This data is sourced from the Environment Agency and Natural Resources Wales.*

## 5.8 Potable abstractions

**Records within 2000m**

**0**

Licensed potable water abstractions for sites extracting more than 20 cubic metres of water a day and includes active and historical records. The data may be for a single abstraction point, a stretch of watercourse or a larger area.

*This data is sourced from the Environment Agency and Natural Resources Wales.*



## 5.9 Source Protection Zones

<b>Records within 500m</b>	<b>1</b>
----------------------------	----------

Source Protection Zones define the sensitivity of an area around a potable abstraction site to contamination. Features are displayed on the Abstractions and Source Protection Zones map on [page 45 >](#)

ID	Location	Type	Description
1	On site	1	Inner catchment

*This data is sourced from the Environment Agency and Natural Resources Wales.*

## 5.10 Source Protection Zones (confined aquifer)

<b>Records within 500m</b>	<b>0</b>
----------------------------	----------

Source Protection Zones in the confined aquifer define the sensitivity around a deep groundwater abstraction to contamination. A confined aquifer would normally be protected from contamination by overlying geology and is only considered a sensitive resource if deep excavation/drilling is taking place.

*This data is sourced from the Environment Agency and Natural Resources Wales.*

## 6 Hydrology

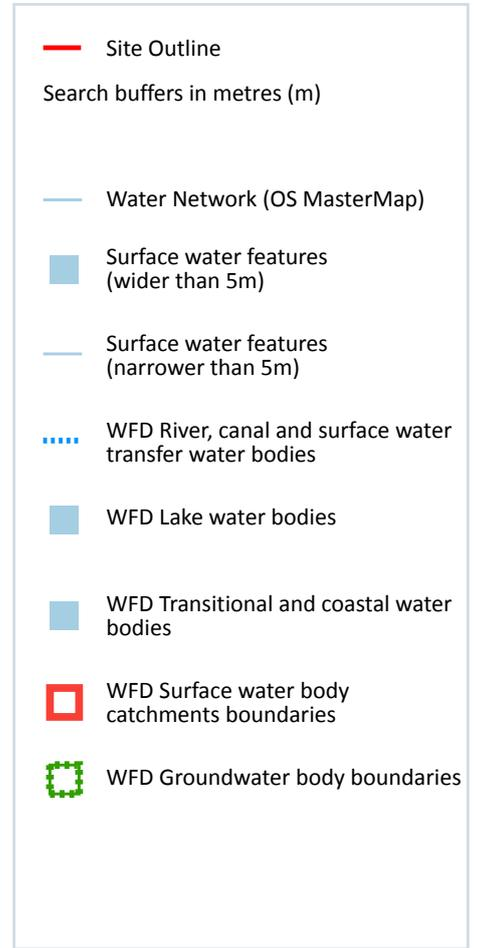
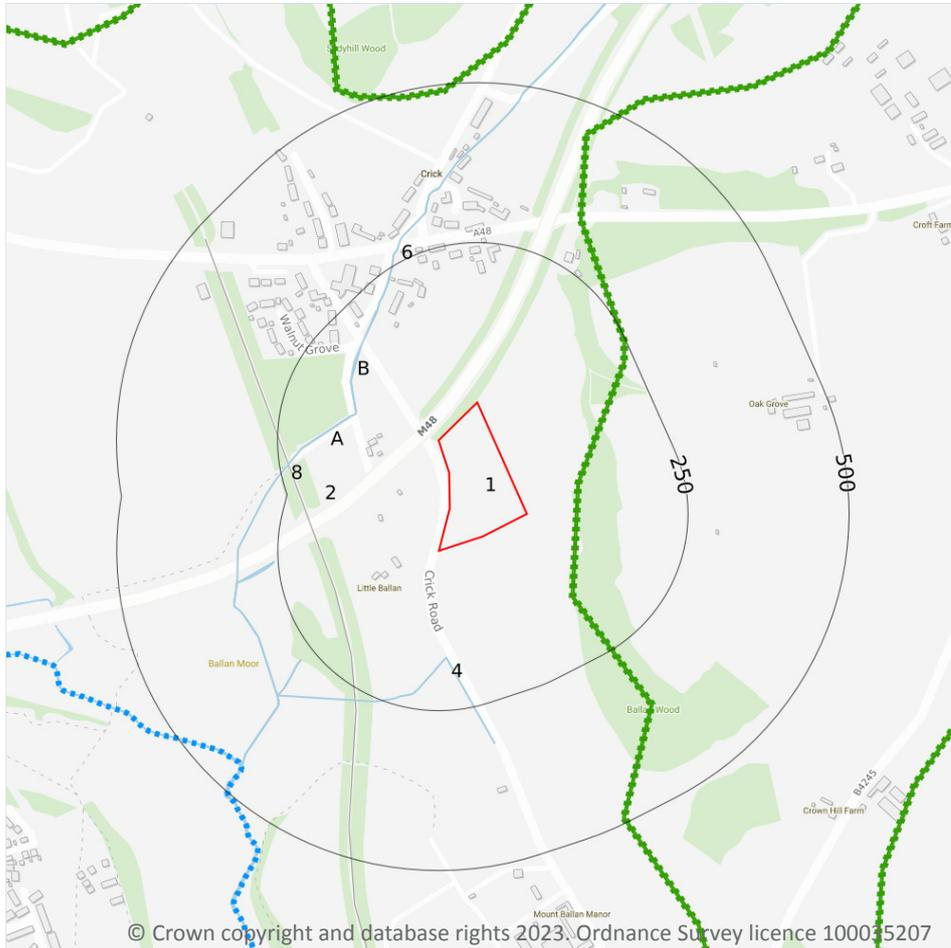

### 6.1 Water Network (OS MasterMap)

Records within 250m

5

Detailed water network of Great Britain showing the flow and precise central course of every river, stream, lake and canal.

Features are displayed on the Hydrology map on [page 50 >](#)

ID	Location	Type of water feature	Ground level	Permanence	Name
A	134m NW	Inland river not influenced by normal tidal action.	On ground surface	Watercourse contains water year round (in normal circumstances)	-

ID	Location	Type of water feature	Ground level	Permanence	Name
B	134m NW	Inland river not influenced by normal tidal action.	On ground surface	Watercourse contains water year round (in normal circumstances)	-
4	167m S	Inland river not influenced by normal tidal action.	On ground surface	Watercourse contains water year round (in normal circumstances)	-
6	210m NW	Inland river not influenced by normal tidal action.	On ground surface	Watercourse contains water year round (in normal circumstances)	-
8	213m W	Inland river not influenced by normal tidal action.	Underground	Watercourse contains water year round (in normal circumstances)	-

This data is sourced from the Ordnance Survey.

## 6.2 Surface water features

**Records within 250m**

**4**

Covering rivers, streams and lakes (some overlap with OS MasterMap Water Network data in previous section) but additionally covers smaller features such as ponds. Rivers and streams narrower than 5m are represented as a single line. Lakes, ponds and rivers or streams wider than 5m are represented as polygons.

Features are displayed on the Hydrology map on [page 50 >](#)

This data is sourced from the Ordnance Survey.

## 6.3 WFD Surface water body catchments

**Records on site**

**1**

The Water Framework Directive is an EU-led framework for the protection of inland surface waters, estuaries, coastal waters and groundwater through river basin-level management planning. In terms of surface water, these basins are broken down into smaller units known as management, operational and water body catchments.

Features are displayed on the Hydrology map on [page 50 >](#)

ID	Location	Type	Water body catchment	Water body ID	Operational catchment	Management catchment
1	On site	River WB catchment	Nedern Bk - souce to R Severn Estuary	GB109056026880	Usk below Abergavenny	Usk

This data is sourced from the Environment Agency and Natural Resources Wales.



## 6.4 WFD Surface water bodies

**Records identified**

**1**

Surface water bodies under the Directive may be rivers, lakes, estuary or coastal. To achieve the purpose of the Directive, environmental objectives have been set and are reported on for each water body. The progress towards delivery of the objectives is then reported on by the relevant competent authorities at the end of each six-year cycle. The river water body directly associated with the catchment listed in the previous section is detailed below, along with any lake, canal, coastal or artificial water body within 250m of the site.

Features are displayed on the Hydrology map on [page 50 >](#)

ID	Location	Type	Name	Water body ID	Overall rating	Chemical rating	Ecological rating	Year
14	453m SW	River	Nedern Bk - souce to R Severn Estuary	GB109056026880	Poor	Good	Poor	2016

*This data is sourced from the Environment Agency and Natural Resources Wales.*

## 6.5 WFD Groundwater bodies

**Records on site**

**1**

Groundwater bodies are also covered by the Directive and the same regime of objectives and reporting detailed in the previous section is in place.

Features are displayed on the Hydrology map on [page 50 >](#)

ID	Location	Name	Water body ID	Overall rating	Chemical rating	Quantitative	Year
2	On site	Usk Devonian Old Red Sandstone	GB40902G201700	Good	Good	Good	2017

*This data is sourced from the Environment Agency and Natural Resources Wales.*

## 7 River and coastal flooding

### 7.1 Risk of flooding from rivers and the sea

Records within 50m

0

The chance of flooding from rivers and/or the sea in any given year, based on cells of 50m within the Risk of Flooding from Rivers and Sea (RoFRaS)/Flood Risk Assessment Wales (FRAW) models. Each cell is allocated one of four flood risk categories, taking into account flood defences and their condition. The risk categories for RoFRaS for rivers and the sea and FRAW for rivers are; Very low (less than 1 in 1000 chance in any given year), Low (less than 1 in 100 but greater than or equal to 1 in 1000 chance), Medium (less than 1 in 30 but greater than or equal to 1 in 100 chance) or High (greater than or equal to 1 in 30 chance). The risk categories for FRAW for the sea are; Very low (less than 1 in 1000 chance in any given year), Low (less than 1 in 200 but greater than or equal to 1 in 1000 chance), Medium (less than 1 in 30 but greater than or equal to 1 in 200 chance) or High (greater than or equal to 1 in 30 chance).

*This data is sourced from the Environment Agency and Natural Resources Wales.*

### 7.2 Historical Flood Events

Records within 250m

0

Records of historic flooding from rivers, the sea, groundwater and surface water. Records began in 1946 when predecessor bodies started collecting detailed information about flooding incidents, although limited details may be included on flooding incidents prior to this date. Takes into account the presence of defences, structures, and other infrastructure where they existed at the time of flooding, and includes flood extents that may have been affected by overtopping, breaches or blockages.

*This data is sourced from the Environment Agency and Natural Resources Wales.*

### 7.3 Flood Defences

Records within 250m

0

Records of flood defences owned, managed or inspected by the Environment Agency and Natural Resources Wales. Flood defences can be structures, buildings or parts of buildings. Typically these are earth banks, stone and concrete walls, or sheet-piling that is used to prevent or control the extent of flooding.

*This data is sourced from the Environment Agency and Natural Resources Wales.*

## 7.4 Areas Benefiting from Flood Defences

Records within 250m

0

Areas that would benefit from the presence of flood defences in a 1 in 100 (1%) chance of flooding each year from rivers or 1 in 200 (0.5%) chance of flooding each year from the sea.

*This data is sourced from the Environment Agency and Natural Resources Wales.*

## 7.5 Flood Storage Areas

Records within 250m

0

Areas that act as a balancing reservoir, storage basin or balancing pond to attenuate an incoming flood peak to a flow level that can be accepted by the downstream channel or to delay the timing of a flood peak so that its volume is discharged over a longer period.

*This data is sourced from the Environment Agency and Natural Resources Wales.*

## River and coastal flooding - Flood Zones

### 7.6 Flood Zone 2

Records within 50m

0

Areas of land at risk of flooding, when the presence of flood defences are ignored. Covering land between Flood Zone 3 (see next section) and the extent of the flooding from rivers or the sea with a 1 in 1000 (0.1%) chance of flooding each year.

*This data is sourced from the Environment Agency and Natural Resources Wales.*

### 7.7 Flood Zone 3

Records within 50m

0

Areas of land at risk of flooding, when the presence of flood defences are ignored. Covering land with a 1 in 100 (1%) or greater chance of flooding each year from rivers or a 1 in 200 (0.5%) or greater chance of flooding each year from the sea.

*This data is sourced from the Environment Agency and Natural Resources Wales.*





## 8 Surface water flooding

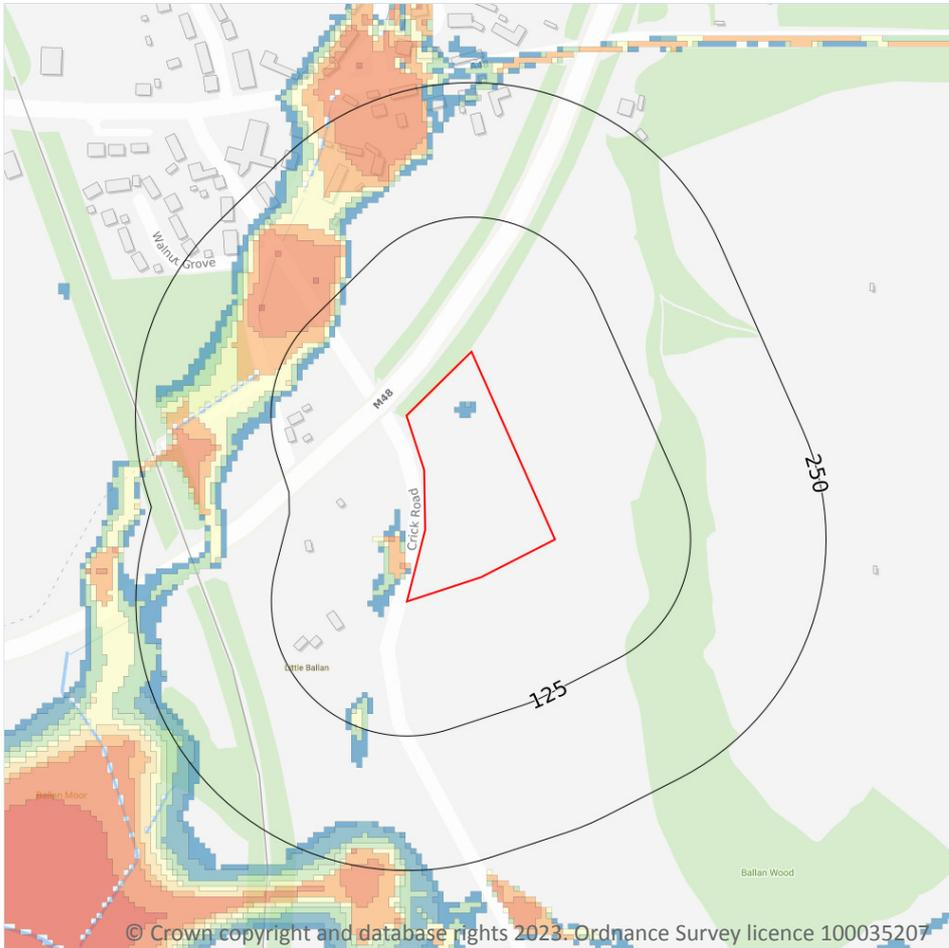

### 8.1 Surface water flooding

Highest risk on site

1 in 1000 year, 0.3m - 1.0m

Highest risk within 50m

1 in 30 year, 0.3m - 1.0m

Ambiental Risk Analytics surface water (pluvial) FloodMap identifies areas likely to flood as a result of extreme rainfall events, i.e. land naturally vulnerable to surface water ponding or flooding. This data set was produced by simulating 1 in 30 year, 1 in 100 year, 1 in 250 year and 1 in 1,000 year rainfall events. Modern urban drainage systems are typically built to cope with rainfall events between 1 in 20 and 1 in 30 years, though some older ones may flood in a 1 in 5 year rainfall event.

Features are displayed on the Surface water flooding map on [page 56 >](#)

The data shown on the map and in the table above shows the highest likelihood of flood events happening at the site. Lower likelihood events may have greater flood depths and hence a greater potential impact on a site.

The table below shows the maximum flood depths for a range of return periods for the site.

Return period	Maximum modelled depth
1 in 1000 year	Between 0.3m and 1.0m
1 in 250 year	Negligible
1 in 100 year	Negligible
1 in 30 year	Negligible

*This data is sourced from Ambiental Risk Analytics.*

## 9 Groundwater flooding

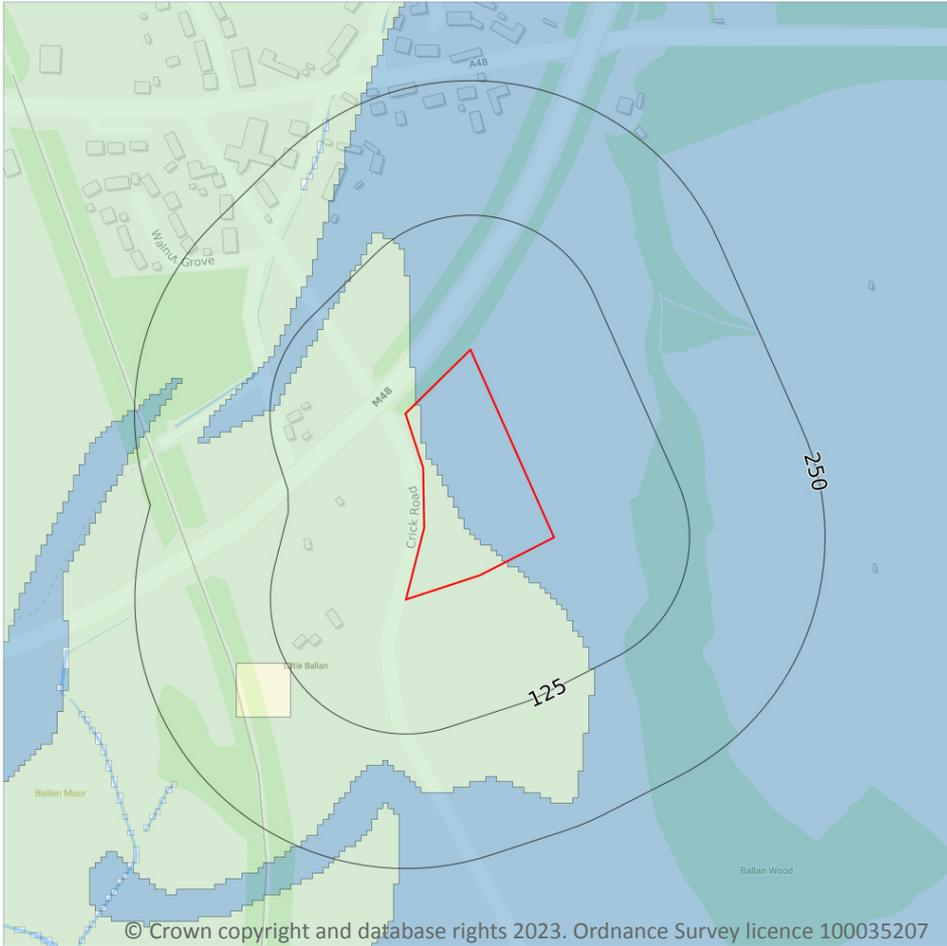

### 9.1 Groundwater flooding

Highest risk on site

Low

Highest risk within 50m

Low

Groundwater flooding is caused by unusually high groundwater levels. It occurs when the water table rises above the ground surface or within underground structures such as basements or cellars. Groundwater flooding tends to exhibit a longer duration than surface water flooding, possibly lasting for weeks or months, and as a result it can cause significant damage to property. This risk assessment is based on a 1 in 100 year return period and a 5m Digital Terrain Model (DTM).

Features are displayed on the Groundwater flooding map on [page 58](#) >

*This data is sourced from Ambiantal Risk Analytics.*

## 10 Environmental designations

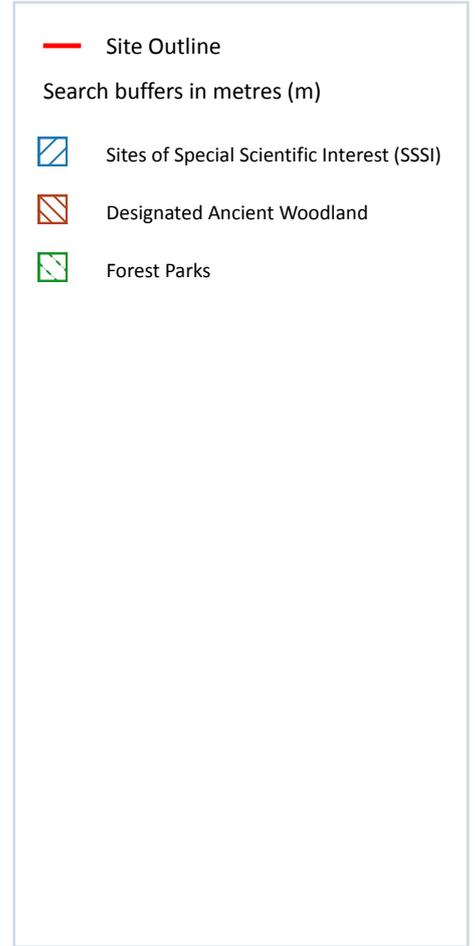
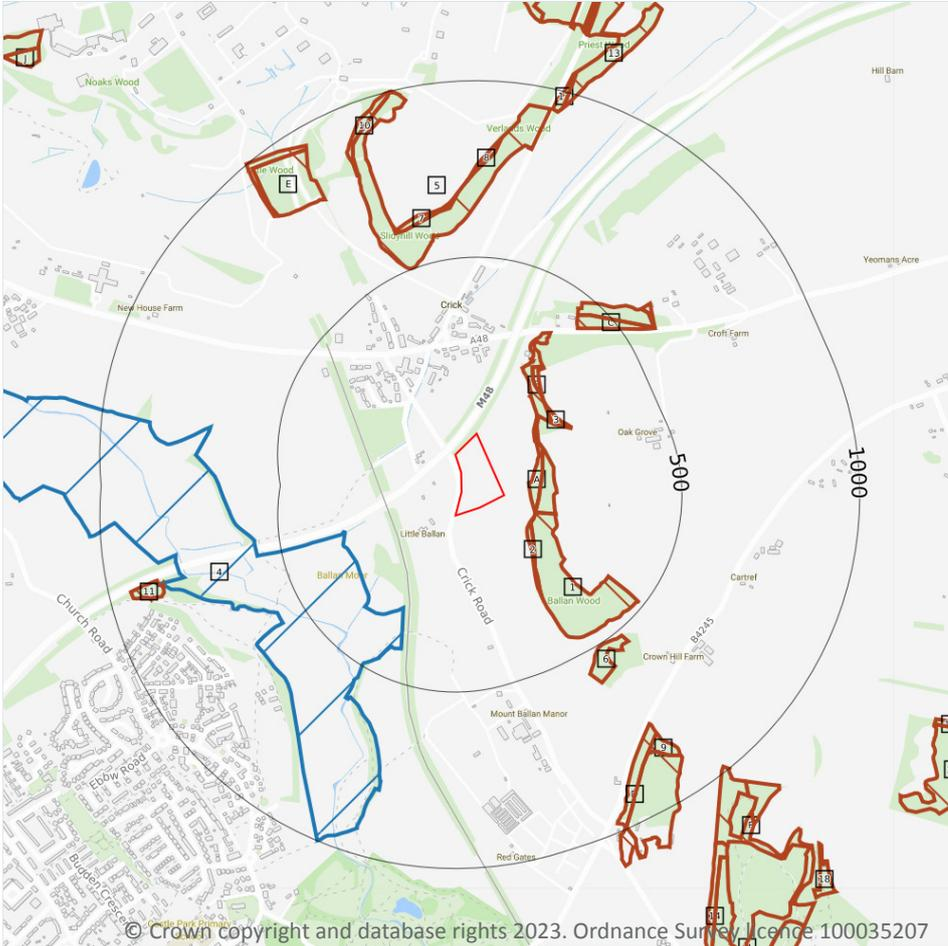

### 10.1 Sites of Special Scientific Interest (SSSI)

Records within 2000m

4

Sites providing statutory protection for the best examples of UK flora, fauna, or geological or physiographical features. Originally notified under the National Parks and Access to the Countryside Act 1949, SSSIs were re-notified under the Wildlife and Countryside Act 1981. Improved provisions for the protection and management of SSSIs were introduced by the Countryside and Rights of Way Act 2000 (in England and Wales) and (in Scotland) by the Nature Conservation (Scotland) Act 2004 and the Wildlife and Natural Environment (Scotland) Act 2010.

Features are displayed on the Environmental designations map on [page 59](#) >

ID	Location	Name	Data source
4	300m SW	Nedern Brook Wetlands, Caldicot	Natural Resources Wales



ID	Location	Name	Data source
-	1264m N	Dinham Meadows	Natural Resources Wales
-	1682m N	Dinham Meadows	Natural Resources Wales
-	1781m W	Brockwells Meadows	Natural Resources Wales

*This data is sourced from Natural England, Natural Resources Wales and Scottish Natural Heritage.*

## 10.2 Conserved wetland sites (Ramsar sites)

**Records within 2000m**

**0**

Ramsar sites are designated under the Convention on Wetlands of International Importance, agreed in Ramsar, Iran, in 1971. They cover all aspects of wetland conservation and wise use, recognizing wetlands as ecosystems that are extremely important for biodiversity conservation in general and for the well-being of human communities. These sites cover a broad definition of wetland; marsh, fen, peatland or water, whether natural or artificial, permanent or temporary, with water that is static or flowing, fresh, brackish or salt, and even some marine areas.

*This data is sourced from Natural England, Natural Resources Wales and Scottish Natural Heritage.*

## 10.3 Special Areas of Conservation (SAC)

**Records within 2000m**

**0**

Areas which have been identified as best representing the range and variety within the European Union of habitats and (non-bird) species listed on Annexes I and II to the Directive. SACs are designated under the EC Habitats Directive.

*This data is sourced from Natural England, Natural Resources Wales and Scottish Natural Heritage.*

## 10.4 Special Protection Areas (SPA)

**Records within 2000m**

**0**

Sites classified by the UK Government under the EC Birds Directive, SPAs are areas of the most important habitat for rare (listed on Annex I to the Directive) and migratory birds within the European Union.

*This data is sourced from Natural England, Natural Resources Wales and Scottish Natural Heritage.*

## 10.5 National Nature Reserves (NNR)

Records within 2000m

0

Sites containing examples of some of the most important natural and semi-natural terrestrial and coastal ecosystems in Great Britain. They are managed to conserve their habitats, provide special opportunities for scientific study or to provide public recreation compatible with natural heritage interests.

*This data is sourced from Natural England, Natural Resources Wales and Scottish Natural Heritage.*

## 10.6 Local Nature Reserves (LNR)

Records within 2000m

0

Sites managed for nature conservation, and to provide opportunities for research and education, or simply enjoying and having contact with nature. They are declared by local authorities under the National Parks and Access to the Countryside Act 1949 after consultation with the relevant statutory nature conservation agency.

*This data is sourced from Natural England, Natural Resources Wales and Scottish Natural Heritage.*

## 10.7 Designated Ancient Woodland

Records within 2000m

69

Ancient woodlands are classified as areas which have been wooded continuously since at least 1600 AD. This includes semi-natural woodland and plantations on ancient woodland sites. 'Wooded continuously' does not mean there is or has previously been continuous tree cover across the whole site, and not all trees within the woodland have to be old.

Features are displayed on the Environmental designations map on [page 59 >](#)

ID	Location	Name	Woodland Type
A	73m E	Unknown	Restored Ancient Woodland Site
A	97m SE	Unknown	Restored Ancient Woodland Site
1	100m SE	Unknown	Ancient Semi Natural Woodland
2	104m SE	Unknown	Ancient Semi Natural Woodland
B	141m NE	Unknown	Ancient Semi Natural Woodland
3	203m NE	Unknown	Restored Ancient Woodland Site
B	211m NE	Unknown	Ancient Semi Natural Woodland
C	412m NE	Unknown	Ancient Semi Natural Woodland
C	440m NE	Unknown	Ancient Semi Natural Woodland
5	502m N	Unknown	Ancient Semi Natural Woodland



ID	Location	Name	Woodland Type
6	505m SE	Unknown	Restored Ancient Woodland Site
7	610m N	Unknown	Ancient Semi Natural Woodland
8	714m N	Unknown	Ancient Semi Natural Woodland
D	766m SE	Unknown	Restored Ancient Woodland Site
E	788m NW	Unknown	Ancient Semi Natural Woodland
9	799m SE	Unknown	Ancient Semi Natural Woodland
10	803m N	Unknown	Ancient Semi Natural Woodland
E	831m NW	Unknown	Ancient Semi Natural Woodland
D	834m SE	Unknown	Restored Ancient Woodland Site
11	846m W	Unknown	Ancient Semi Natural Woodland
12	940m N	Unknown	Ancient Semi Natural Woodland
13	953m N	Unknown	Ancient Semi Natural Woodland
F	985m SE	Unknown	Ancient Semi Natural Woodland
F	1058m SE	Unknown	Ancient Semi Natural Woodland
14	1151m SE	Unknown	Restored Ancient Woodland Site
G	1171m N	Unknown	Ancient Semi Natural Woodland
G	1175m N	Unknown	Plantation on Ancient Woodland Site
15	1180m N	Unknown	Ancient Semi Natural Woodland
G	1181m N	Unknown	Plantation on Ancient Woodland Site
G	1181m N	Unknown	Plantation on Ancient Woodland Site
G	1183m N	Unknown	Ancient Semi Natural Woodland
H	1192m SE	Unknown	Restored Ancient Woodland Site
-	1288m N	Unknown	Ancient Semi Natural Woodland
18	1326m SE	Unknown	Ancient Semi Natural Woodland
19	1370m SE	Unknown	Ancient Semi Natural Woodland
20	1373m SE	Unknown	Ancient Semi Natural Woodland
H	1381m SE	Unknown	Restored Ancient Woodland Site
-	1406m N	Unknown	Ancient Semi Natural Woodland



ID	Location	Name	Woodland Type
-	1449m W	Unknown	Ancient Semi Natural Woodland
-	1515m W	Unknown	Restored Ancient Woodland Site
-	1541m N	Unknown	Plantation on Ancient Woodland Site
-	1600m NE	Unknown	Ancient Semi Natural Woodland
J	1617m NW	Unknown	Restored Ancient Woodland Site
-	1619m N	Unknown	Ancient Semi Natural Woodland
-	1626m N	Unknown	Plantation on Ancient Woodland Site
-	1634m N	Unknown	Plantation on Ancient Woodland Site
-	1635m N	Unknown	Restored Ancient Woodland Site
J	1644m NW	Unknown	Restored Ancient Woodland Site
-	1676m N	Unknown	Plantation on Ancient Woodland Site
-	1695m N	Unknown	Plantation on Ancient Woodland Site
-	1698m N	Unknown	Restored Ancient Woodland Site
-	1714m E	Unknown	Ancient Semi Natural Woodland
-	1722m N	Unknown	Plantation on Ancient Woodland Site
-	1755m E	Unknown	Restored Ancient Woodland Site
-	1783m NE	Unknown	Restored Ancient Woodland Site
-	1786m W	Unknown	Ancient Woodland Site of Unknown Category
-	1789m N	Unknown	Ancient Semi Natural Woodland
-	1792m NW	Unknown	Ancient Semi Natural Woodland
-	1840m W	Unknown	Restored Ancient Woodland Site
-	1859m SE	Unknown	Ancient Semi Natural Woodland
-	1878m N	Unknown	Plantation on Ancient Woodland Site
-	1893m E	Unknown	Restored Ancient Woodland Site
-	1894m E	Unknown	Ancient Semi Natural Woodland
-	1895m N	Unknown	Plantation on Ancient Woodland Site
-	1918m E	Unknown	Restored Ancient Woodland Site
-	1925m N	Unknown	Ancient Semi Natural Woodland





ID	Location	Name	Woodland Type
-	1929m W	Unknown	Ancient Semi Natural Woodland
-	1963m NE	Unknown	Restored Ancient Woodland Site
-	1975m N	Unknown	Ancient Semi Natural Woodland

*This data is sourced from Natural England, Natural Resources Wales and Scottish Natural Heritage.*

## 10.8 Biosphere Reserves

**Records within 2000m**

**0**

Biosphere Reserves are internationally recognised by UNESCO as sites of excellence to balance conservation and socioeconomic development between nature and people. They are recognised under the Man and the Biosphere (MAB) Programme with the aim of promoting sustainable development founded on the work of the local community.

*This data is sourced from Natural England, Natural Resources Wales and Scottish Natural Heritage.*

## 10.9 Forest Parks

**Records within 2000m**

**1**

These are areas managed by the Forestry Commission designated on the basis of recreational, conservation or scenic interest.

Features are displayed on the Environmental designations map on [page 59 >](#)

ID	Location	Name
-	1924m N	Wye Valley Woods

*This data is sourced from the Forestry Commission.*

## 10.10 Marine Conservation Zones

**Records within 2000m**

**0**

A type of marine nature reserve in UK waters established under the Marine and Coastal Access Act (2009). They are designated with the aim to protect nationally important, rare or threatened habitats and species.

*This data is sourced from Natural England, Natural Resources Wales and Scottish Natural Heritage.*



## 10.11 Green Belt

Records within 2000m

0

Areas designated to prevent urban sprawl by keeping land permanently open.

*This data is sourced from the Ministry of Housing, Communities and Local Government.*

## 10.12 Proposed Ramsar sites

Records within 2000m

0

Ramsar sites are areas listed as a Wetland of International Importance under the Convention on Wetlands of International Importance especially as Waterfowl Habitat (the Ramsar Convention) 1971. The sites here supplied have a status of 'Proposed' having been identified for potential adoption under the framework.

*This data is sourced from Natural England.*

## 10.13 Possible Special Areas of Conservation (pSAC)

Records within 2000m

0

Special Areas of Conservation are areas which have been identified as best representing the range and variety within the European Union of habitats and (non-bird) species listed on Annexes I and II to the Directive. SACs are designated under the EC Habitats Directive. Those sites supplied here are those with a status of 'Possible' having been identified for potential adoption under the framework.

*This data is sourced from Natural England and Natural Resources Wales.*

## 10.14 Potential Special Protection Areas (pSPA)

Records within 2000m

0

Special Protection Areas (SPAs) are areas designated (or 'classified') under the European Union Wild Birds Directive for the protection of nationally and internationally important populations of wild birds. Those sites supplied here are those with a status of 'Potential' having been identified for potential adoption under the framework.

*This data is sourced from Natural England.*

## 10.15 Nitrate Sensitive Areas

Records within 2000m

0

Areas where nitrate concentrations in drinking water sources exceeded or was at risk of exceeding the limit of 50 mg/l set by the 1980 EC Drinking Water Directive. Voluntary agricultural measures as a means of reducing the levels of nitrate were introduced by DEFRA as MAFF, with payments being made to farmers who complied. The scheme was started as a pilot in 1990 in ten areas, later implemented within 32 areas. The scheme was



closed to further new entrants in 1998, although existing agreements continued for their full term. All Nitrate Sensitive Areas fell within the areas designated as Nitrate Vulnerable Zones (NVZs) in 1996 under the EC Nitrate Directive (91/676/EEC).

*This data is sourced from Natural England.*

## 10.16 Nitrate Vulnerable Zones

Records within 2000m

0

Areas at risk from agricultural nitrate pollution designated under the EC Nitrate Directive (91/676/EEC). These are areas of land that drain into waters polluted by nitrates. Farmers operating within these areas have to follow mandatory rules to tackle nitrate loss from agriculture.

*This data is sourced from Natural England and Natural Resources Wales.*

## SSSI Impact Zones and Units

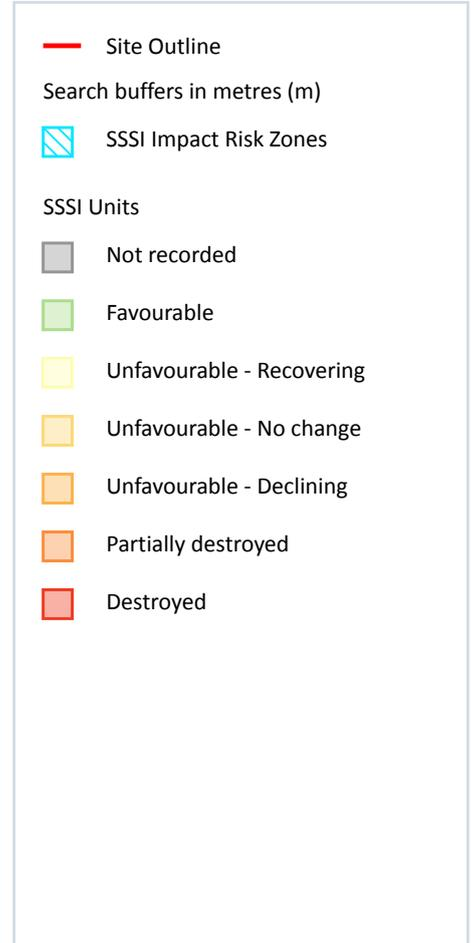
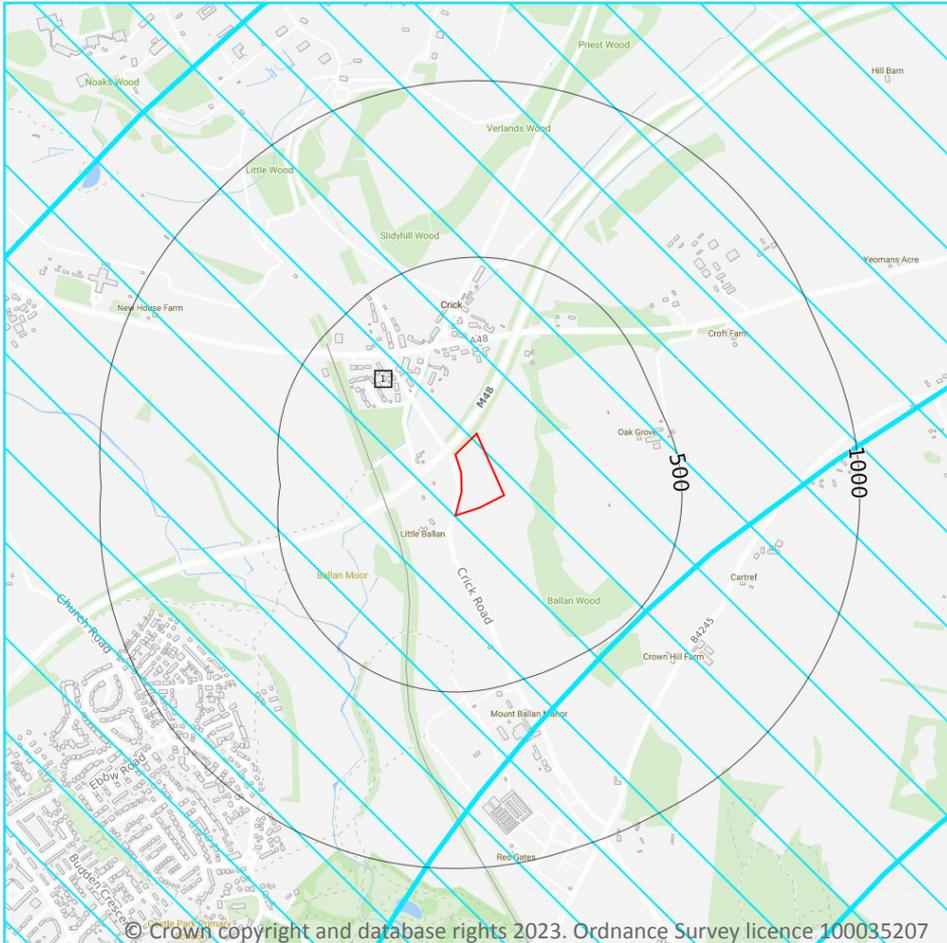

### 10.17 SSSI Impact Risk Zones

Records on site

1

Developed to allow rapid initial assessment of the potential risks to SSSIs posed by development proposals. They define zones around each SSSI which reflect the particular sensitivities of the features for which it is notified and indicate the types of development proposal which could potentially have adverse impacts.

Features are displayed on the SSSI Impact Zones and Units map on [page 67](#) >

ID	Location	Type of developments requiring consultation
1	On site	<p>Infrastructure - Airports, helipads and other aviation proposals.</p> <p>Air pollution - Any industrial/agricultural development that could cause AIR POLLUTION (incl: industrial processes, livestock &amp; poultry units with floorspace &gt; 500m<sup>2</sup>, slurry lagoons &amp; digestate stores &gt; 750m<sup>2</sup>, manure stores &gt; 3500t).</p> <p>Combustion - General combustion processes &gt;50MW energy input. Incl: energy from waste incineration, other incineration, landfill gas generation plant, pyrolysis/gasification, anaerobic digestion, sewage treatment works, other incineration/ combustion.</p>

*This data is sourced from Natural England.*

## 10.18 SSSI Units

<b>Records within 2000m</b>	<b>0</b>
-----------------------------	----------

Divisions of SSSIs used to record management and condition details. Units are the smallest areas for which Natural England gives a condition assessment, however, the size of units varies greatly depending on the types of management and the conservation interest.

*This data is sourced from Natural England and Natural Resources Wales.*

## 11 Visual and cultural designations

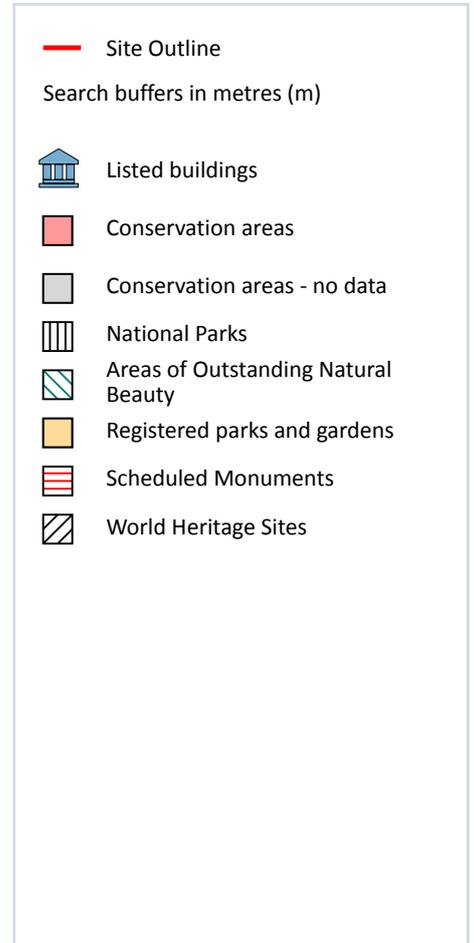
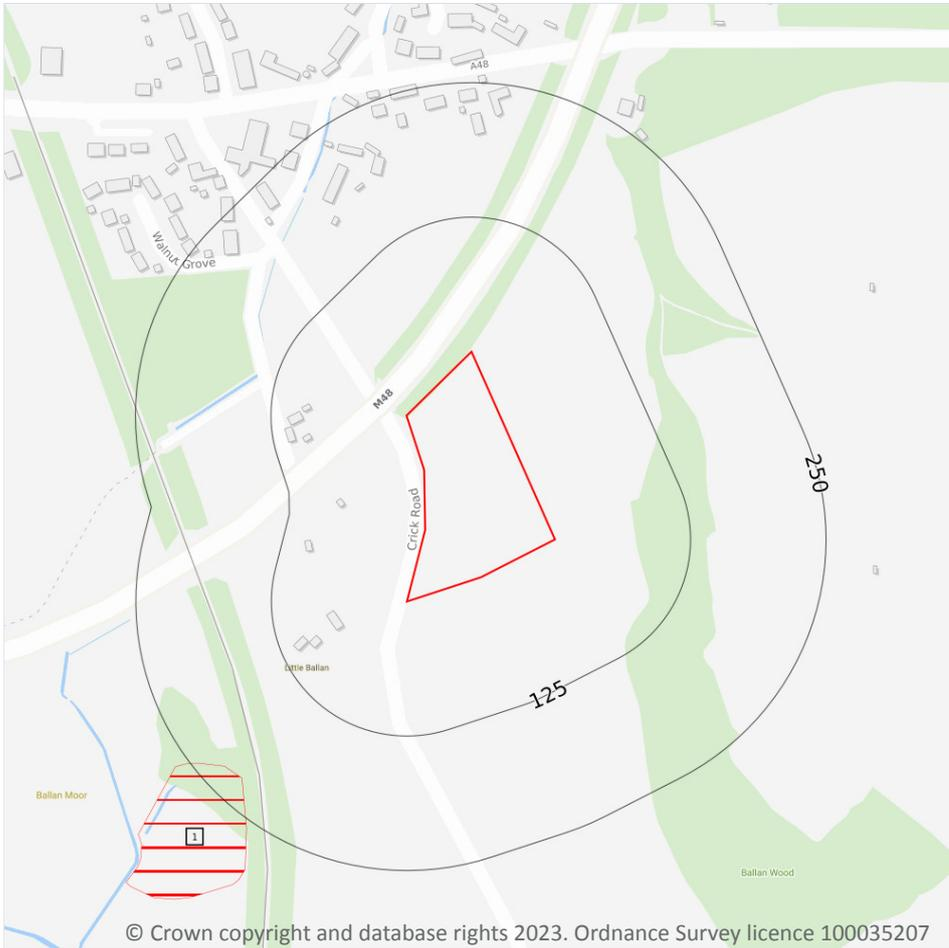

### 11.1 World Heritage Sites

Records within 250m

0

Sites designated for their globally important cultural or natural interest requiring appropriate management and protection measures. World Heritage Sites are designated to meet the UK's commitments under the World Heritage Convention.

*This data is sourced from Historic England, Cadw and Historic Environment Scotland.*

## 11.2 Area of Outstanding Natural Beauty

Records within 250m

0

Areas of Outstanding Natural Beauty (AONB) are conservation areas, chosen because they represent 18% of the finest countryside. Each AONB has been designated for special attention because of the quality of their flora, fauna, historical and cultural associations, and/or scenic views. The National Parks and Access to the Countryside Act of 1949 created AONBs and the Countryside and Rights of Way Act, 2000 added further regulation and protection. There are likely to be restrictions to some developments within these areas.

*This data is sourced from Natural England, Natural Resources Wales and Scottish Natural Heritage.*

## 11.3 National Parks

Records within 250m

0

In England and Wales, the purpose of National Parks is to conserve and enhance landscapes within the countryside whilst promoting public enjoyment of them and having regard for the social and economic well-being of those living within them. In Scotland National Parks have the additional purpose of promoting the sustainable use of the natural resources of the area and the sustainable social and economic development of its communities. The National Parks and Access to the Countryside Act 1949 established the National Park designation in England and Wales, and The National Parks (Scotland) Act 2000 in Scotland.

*This data is sourced from Natural England, Natural Resources Wales and the Scottish Government.*

## 11.4 Listed Buildings

Records within 250m

0

Buildings listed for their special architectural or historical interest. Building control in the form of 'listed building consent' is required in order to make any changes to that building which might affect its special interest. Listed buildings are graded to indicate their relative importance, however building controls apply to all buildings equally, irrespective of their grade, and apply to the interior and exterior of the building in its entirety, together with any curtilage structures.

*This data is sourced from Historic England, Cadw and Historic Environment Scotland.*

## 11.5 Conservation Areas

Records within 250m

0

Local planning authorities are obliged to designate as conservation areas any parts of their own area that are of special architectural or historic interest, the character and appearance of which it is desirable to preserve or enhance. Designation of a conservation area gives broader protection than the listing of individual buildings. All the features within the area, listed or otherwise, are recognised as part of its character. Conservation area designation is the means of recognising the importance of all factors and of ensuring that planning decisions address the quality of the landscape in its broadest sense.



*This data is sourced from Historic England, Cadw and Historic Environment Scotland.*

## 11.6 Scheduled Ancient Monuments

Records within 250m

1

A scheduled monument is an historic building or site that is included in the Schedule of Monuments kept by the Secretary of State for Digital, Culture, Media and Sport. The regime is set out in the Ancient Monuments and Archaeological Areas Act 1979. The Schedule of Monuments has c.20,000 entries and includes sites such as Roman remains, burial mounds, castles, bridges, earthworks, the remains of deserted villages and industrial sites. Monuments are not graded, but all are, by definition, considered to be of national importance.

Features are displayed on the Visual and cultural designations map on [page 69 >](#)

ID	Location	Ancient monument name	Reference number
1	224m SW	The Berries Mound & Bailey Castle	2966

*This data is sourced from Historic England, Cadw and Historic Environment Scotland.*

## 11.7 Registered Parks and Gardens

Records within 250m

0

Parks and gardens assessed to be of particular interest and of special historic interest. The emphasis being on 'designed' landscapes, rather than on planting or botanical importance. Registration is a 'material consideration' in the planning process, meaning that planning authorities must consider the impact of any proposed development on the special character of the landscape.

*This data is sourced from Historic England, Cadw and Historic Environment Scotland.*



## 12 Agricultural designations

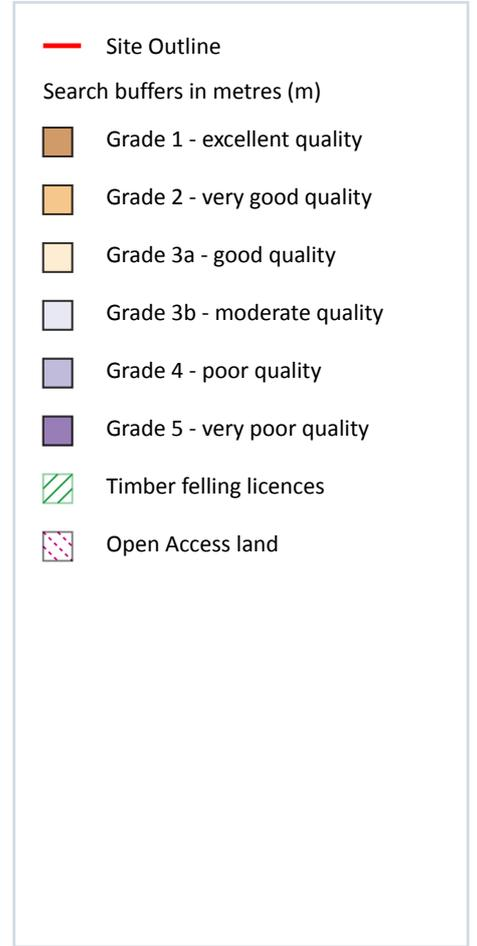
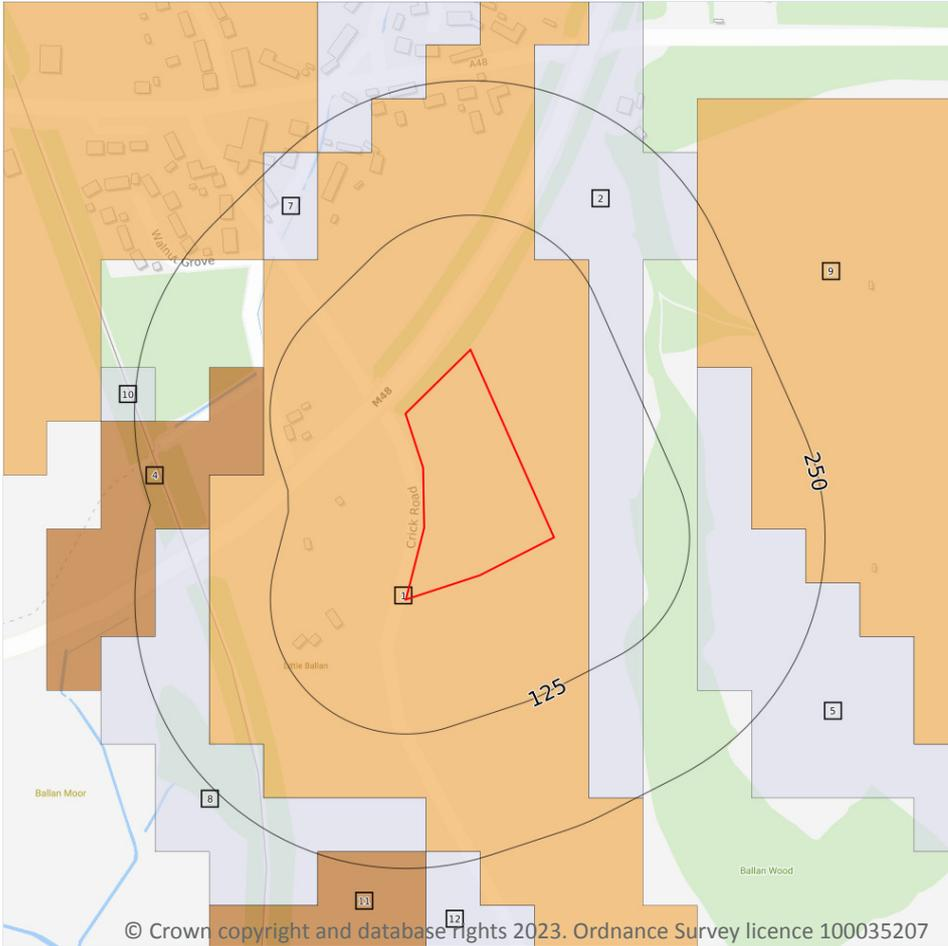

### 12.1 Agricultural Land Classification

Records within 250m

10

Classification of the quality of agricultural land taking into consideration multiple factors including climate, physical geography and soil properties. It should be noted that the categories for the grading of agricultural land are not consistent across England, Wales and Scotland.

Features are displayed on the Agricultural designations map on [page 72 >](#)

ID	Location	Classification	Description
1	On site	Grade 2	Good quality agricultural land
2	32m SE	Grade 3b	Moderate quality agricultural land
4	131m W	Grade 1	Excellent quality agricultural land

ID	Location	Classification	Description
5	132m E	Grade 3b	Moderate quality agricultural land
7	159m NW	Grade 3b	Moderate quality agricultural land
8	181m SW	Grade 3b	Moderate quality agricultural land
9	182m E	Grade 2	Good quality agricultural land
10	231m W	Grade 3b	Moderate quality agricultural land
11	234m S	Grade 1	Excellent quality agricultural land
12	235m S	Grade 3b	Moderate quality agricultural land

*This data is sourced from Natural Resources Wales.*

## 12.2 Open Access Land

**Records within 250m**

**0**

The Countryside and Rights of Way Act 2000 (CROW Act) gives a public right of access to land without having to use paths. Access land includes mountains, moors, heaths and downs that are privately owned. It also includes common land registered with the local council and some land around the England Coast Path. Generally permitted activities on access land are walking, running, watching wildlife and climbing.

*This data is sourced from Natural England and Natural Resources Wales.*

## 12.3 Tree Felling Licences

**Records within 250m**

**0**

Felling Licence Application (FLA) areas approved by Forestry Commission England. Anyone wishing to fell trees must ensure that a licence or permission under a grant scheme has been issued by the Forestry Commission before any felling is carried out or that one of the exceptions apply.

*This data is sourced from the Forestry Commission.*

## 12.4 Environmental Stewardship Schemes

**Records within 250m**

**0**

Environmental Stewardship covers a range of schemes that provide financial incentives to farmers, foresters and land managers to look after and improve the environment. The schemes identified may be historical schemes that have now expired, or may still be active.

*This data is sourced from Natural England.*



## 12.5 Countryside Stewardship Schemes

Records within 250m

0

Countryside Stewardship covers a range of schemes that provide financial incentives to farmers, foresters and land managers to look after and improve the environment. Main objectives are to improve the farmed environment for wildlife and to reduce diffuse water pollution.

*This data is sourced from Natural England.*



## 13 Habitat designations

### 13.1 Priority Habitat Inventory

Records within 250m

0

Habitats of principal importance as named under Natural Environment and Rural Communities Act (2006) Section 41.

*This data is sourced from Natural England.*

### 13.2 Habitat Networks

Records within 250m

0

Habitat networks for 18 priority habitat networks (based primarily, but not exclusively, on the priority habitat inventory) and areas suitable for the expansion of networks through restoration and habitat creation.

*This data is sourced from Natural England.*

### 13.3 Open Mosaic Habitat

Records within 250m

0

Sites verified as Open Mosaic Habitat. Mosaic habitats are brownfield sites that are identified under the UK Biodiversity Action Plan as a priority habitat due to the habitat variation within a single site, supporting an array of invertebrates.

*This data is sourced from Natural England.*

### 13.4 Limestone Pavement Orders

Records within 250m

0

Limestone pavements are outcrops of limestone where the surface has been worn away by natural means over millennia. These rocks have the appearance of paving blocks, hence their name. Not only do they have geological interest, they also provide valuable habitats for wildlife. These habitats are threatened due to their removal for use in gardens and water features. Many limestone pavements have been designated as SSSIs which affords them some protection. In addition, Section 34 of the Wildlife and Countryside Act 1981 gave them additional protection via the creation of Limestone Pavement Orders, which made it a criminal offence to remove any part of the outcrop. The associated Limestone Pavement Priority Habitat is part of the UK Biodiversity Action Plan priority habitat in England.

*This data is sourced from Natural England.*



## 14 Geology 1:10,000 scale - Availability

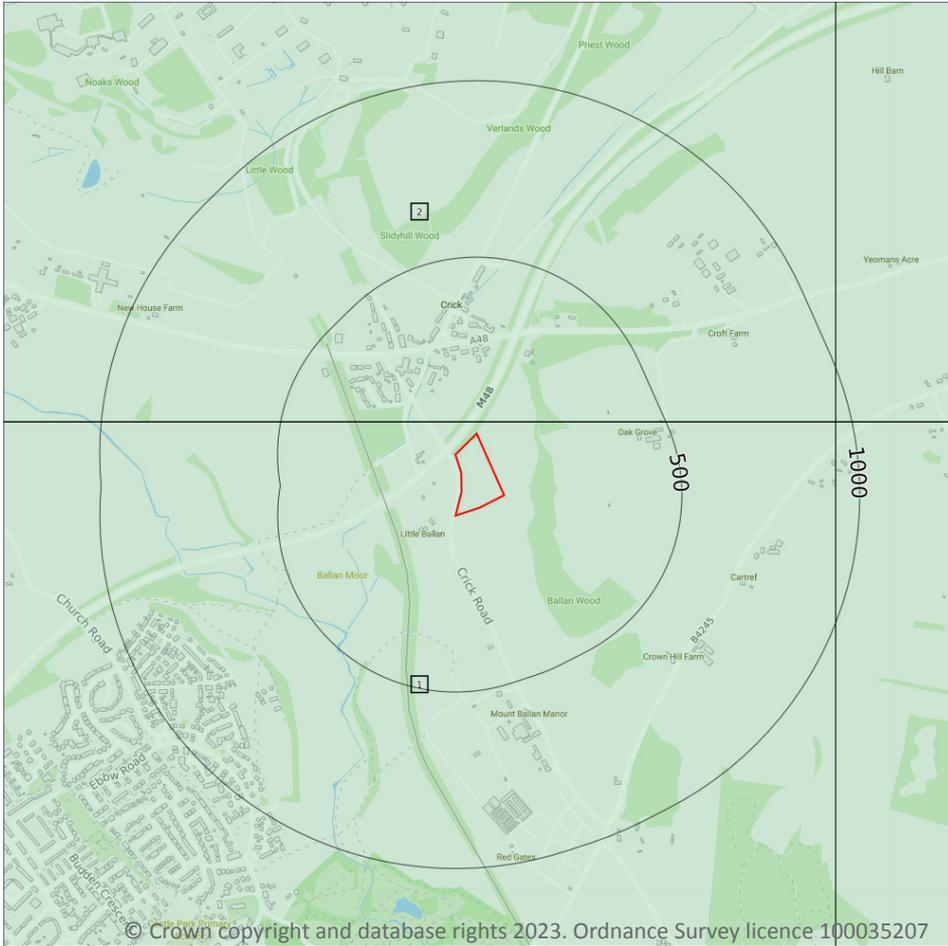

— Site Outline  
 Search buffers in metres (m)

- Full coverage
- Partial coverage
- No coverage

### 14.1 10k Availability

Records within 500m

2

An indication on the coverage of 1:10,000 scale geology data for the site, the most detailed dataset provided by the British Geological Survey. Either 'Full', 'Partial' or 'No coverage' for each geological theme.

Features are displayed on the Geology 1:10,000 scale - Availability map on [page 76 >](#)

ID	Location	Artificial	Superficial	Bedrock	Mass movement	Sheet No.
1	On site	No coverage	Full	Full	No coverage	ST48NE
2	34m N	No coverage	Full	Full	No coverage	ST49SE

This data is sourced from the British Geological Survey.



## Geology 1:10,000 scale - Artificial and made ground

### 14.2 Artificial and made ground (10k)

Records within 500m

0

Details of made, worked, infilled, disturbed and landscaped ground at 1:10,000 scale. Artificial ground can be associated with potentially contaminated material, unpredictable engineering conditions and instability.

*This data is sourced from the British Geological Survey.*



## Geology 1:10,000 scale - Superficial

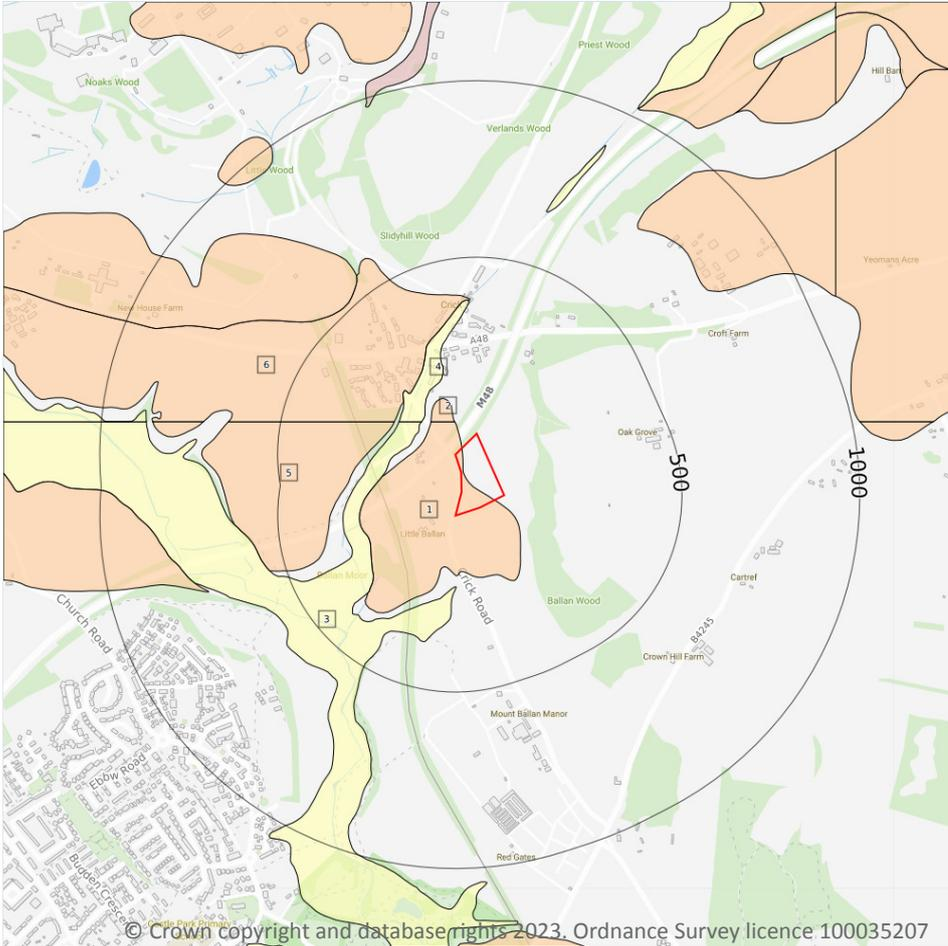

- Site Outline
- Search buffers in metres (m)
- Landslip (10k)
- Superficial geology (10k)  
Please see table for more details.

### 14.3 Superficial geology (10k)

Records within 500m

6

Superficial geological deposits at 1:10,000 scale. Also known as 'drift', these are the youngest geological deposits, formed during the Quaternary. They rest on older deposits or rocks referred to as bedrock.

Features are displayed on the Geology 1:10,000 scale - Superficial map on [page 78 >](#)

ID	Location	LEX Code	Description	Rock description
1	On site	RTD2-XSV	River Terrace Deposits, 2 - Sand And Gravel	Sand And Gravel
2	67m N	RTD2-XSV	River Terrace Deposits, 2 - Sand And Gravel	Sand And Gravel
3	122m NW	ALV-XCZSV	Alluvium - Clay, Silt, Sand And Gravel	Clay, Silt, Sand And Gravel
4	133m NW	ALV-XCZSV	Alluvium - Clay, Silt, Sand And Gravel	Clay, Silt, Sand And Gravel



ID	Location	LEX Code	Description	Rock description
5	195m NW	RTD2-XSV	River Terrace Deposits, 2 - Sand And Gravel	Sand And Gravel
6	195m NW	RTD2-XSV	River Terrace Deposits, 2 - Sand And Gravel	Sand And Gravel

*This data is sourced from the British Geological Survey.*

## 14.4 Landslip (10k)

**Records within 500m**

**0**

Mass movement deposits on BGS geological maps at 1:10,000 scale. Primarily superficial deposits that have moved down slope under gravity to form landslips. These affect bedrock, other superficial deposits and artificial ground.

*This data is sourced from the British Geological Survey.*





## Geology 1:10,000 scale - Bedrock

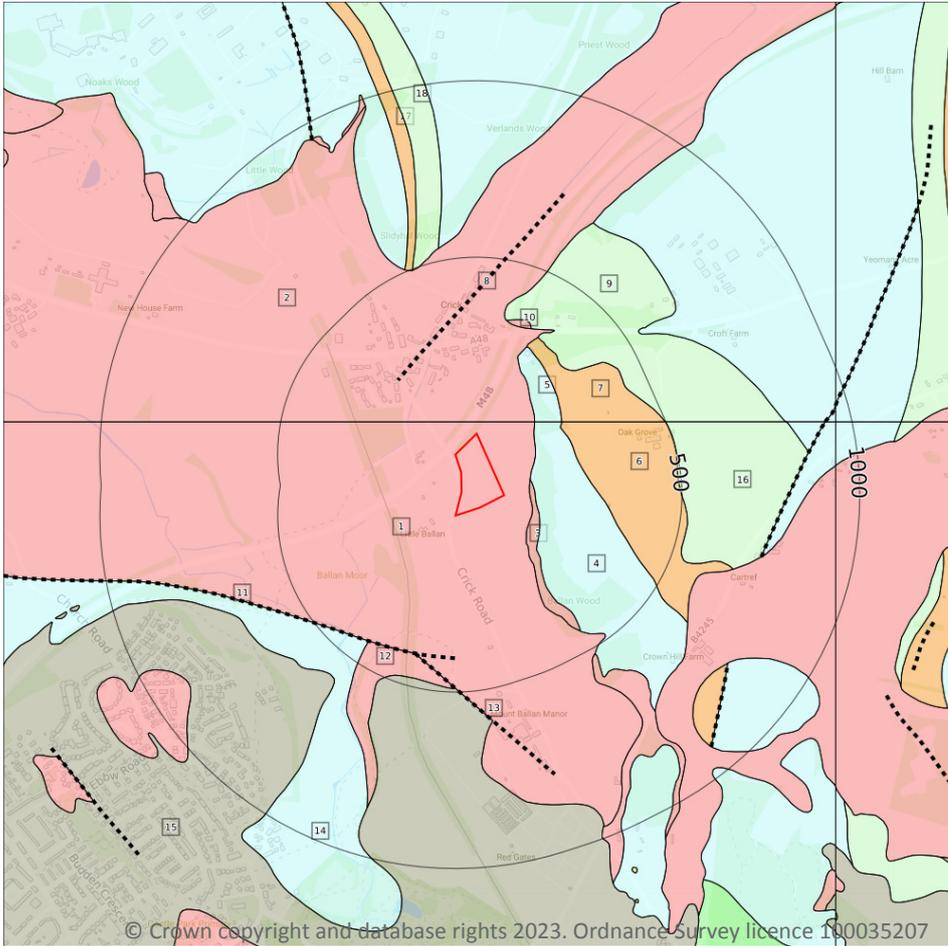

- Site Outline
- Search buffers in metres (m)
- Bedrock faults and other linear features (10k)
- Bedrock geology (10k)  
Please see table for more details.

### 14.5 Bedrock geology (10k)

Records within 500m

15

Bedrock geology at 1:10,000 scale. The main mass of rocks forming the Earth and present everywhere, whether exposed at the surface in outcrops or concealed beneath superficial deposits or water.

Features are displayed on the Geology 1:10,000 scale - Bedrock map on [page 80 >](#)

ID	Location	LEX Code	Description	Rock age
1	On site	MMG-MDST	Mercia Mudstone Group - Mudstone	Rhaetian Age - Early Triassic Epoch
2	34m N	MMG-MDST	Mercia Mudstone Group - Mudstone	Rhaetian Age - Early Triassic Epoch
3	72m E	MMMF-CONG	Mercia Mudstone Group (marginal Facies) - Conglomerate	Triassic Period



ID	Location	LEX Code	Description	Rock age
4	85m E	HBO-LMOOL	Hunts Bay Oolite Subgroup - Ooidal Limestone	Holkerian Age - Arundian Age
5	163m NE	HBO-LMOOL	Hunts Bay Oolite Subgroup - Ooidal Limestone	Holkerian Age - Arundian Age
6	223m NE	CHSA-SDST	Cromhall Sandstone Formation - Sandstone	Brigantian Age - Arundian Age
7	232m NE	CHSA-SDST	Cromhall Sandstone Formation - Sandstone	Brigantian Age - Arundian Age
9	306m NE	LLY-ARLMST	Llanelly Formation - Argillaceous, Muddy Limestone/cementstone/calculutite	Arundian Age
10	325m N	MMMMF-CONG	Mercia Mudstone Group (marginal Facies) - Conglomerate	Triassic Period
12	407m S	MMMMF-CONG	Mercia Mudstone Group (marginal Facies) - Conglomerate	Triassic Period
14	431m SW	HBO-LMOOL	Hunts Bay Oolite Subgroup - Ooidal Limestone	Holkerian Age - Arundian Age
15	475m S	MMG-SDST	Mercia Mudstone Group - Sandstone	Rhaetian Age - Early Triassic Epoch
16	492m E	LLY-ARLMST	Llanelly Formation - Argillaceous, Muddy Limestone/cementstone/calculutite	Arundian Age
17	497m N	CHSA-SDST	Cromhall Sandstone Formation - Sandstone	Brigantian Age - Arundian Age
18	497m N	LLY-ARLMST	Llanelly Formation - Argillaceous, Muddy Limestone/cementstone/calculutite	Arundian Age

This data is sourced from the British Geological Survey.

## 14.6 Bedrock faults and other linear features (10k)

Records within 500m

3

Linear features at the ground or bedrock surface at 1:10,000 scale of six main types; rock, fault, fold axis, mineral vein, alteration area or landform. Features are either observed or inferred, and relate primarily to bedrock.

Features are displayed on the Geology 1:10,000 scale - Bedrock map on [page 80](#) >

ID	Location	Category	Description
8	263m NW	FAULT	Normal fault, inferred; crossmarks on downthrow side
11	403m S	FAULT	Normal fault, inferred; crossmarks on downthrow side
13	407m S	FAULT	Normal fault, inferred; crossmarks on downthrow side



*This data is sourced from the British Geological Survey.*



## 15 Geology 1:50,000 scale - Availability

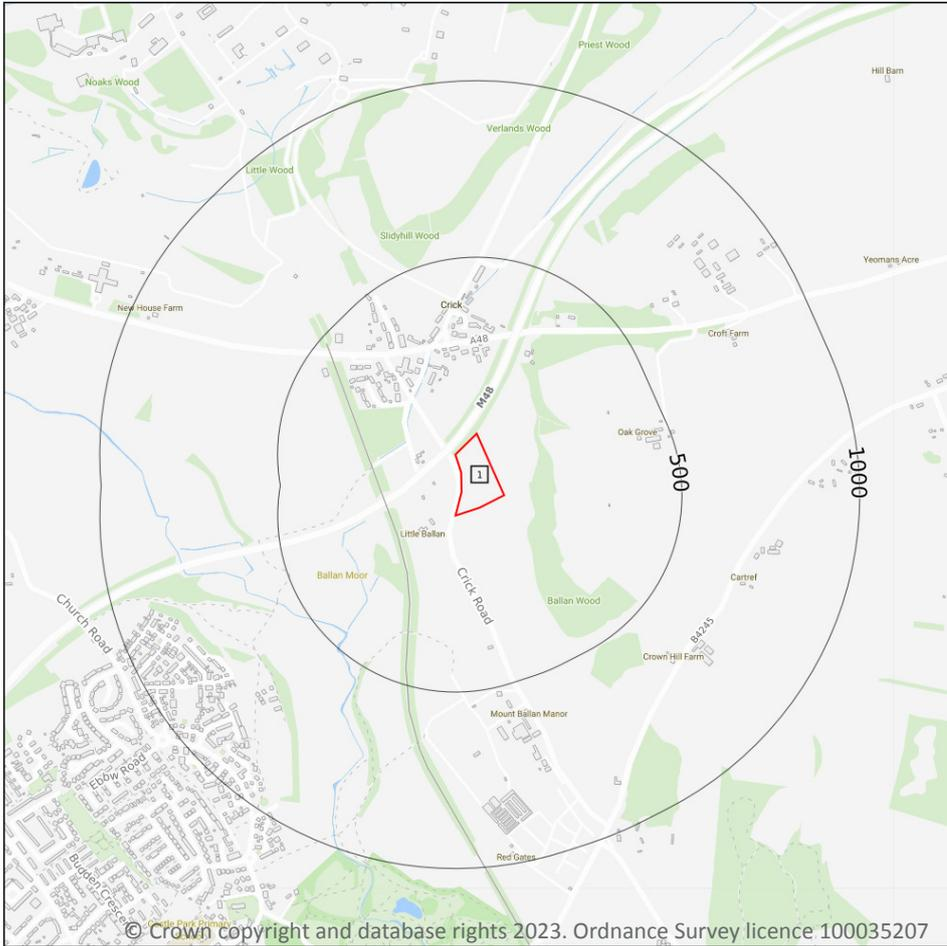

— Site Outline  
Search buffers in metres (m)

□ Geological map tile

### 15.1 50k Availability

Records within 500m

1

An indication on the coverage of 1:50,000 scale geology data for the site. Either 'Full' or 'No coverage' for each geological theme. Where 50k data is not available, this area has been filled in with 625k scale data.

Features are displayed on the Geology 1:50,000 scale - Availability map on [page 83 >](#)

ID	Location	Artificial	Superficial	Bedrock	Mass movement	Sheet No.
1	On site	No coverage	Full	Full	Full	EW250_chepstow_v4

This data is sourced from the British Geological Survey.

## Geology 1:50,000 scale - Artificial and made ground

### 15.2 Artificial and made ground (50k)

Records within 500m

0

Details of made, worked, infilled, disturbed and landscaped ground at 1:50,000 scale. Artificial ground can be associated with potentially contaminated material, unpredictable engineering conditions and instability.

*This data is sourced from the British Geological Survey.*

### 15.3 Artificial ground permeability (50k)

Records within 50m

0

A qualitative classification of estimated rates of vertical movement of water from the ground surface through the unsaturated zone of any artificial deposits (the zone between the land surface and the water table).

*This data is sourced from the British Geological Survey.*



## Geology 1:50,000 scale - Superficial

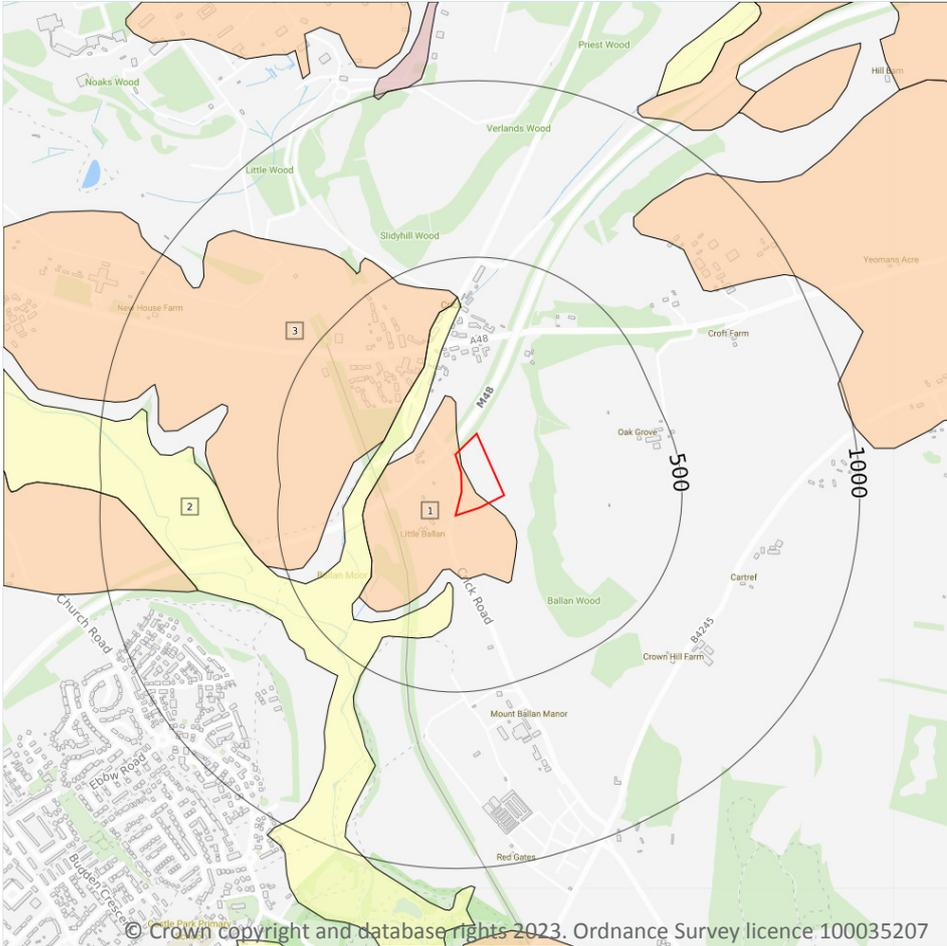

- Site Outline
- Search buffers in metres (m)
- Landslip (50k)
- Superficial geology (50k)  
Please see table for more details.

### 15.4 Superficial geology (50k)

Records within 500m

3

Superficial geological deposits at 1:50,000 scale. Also known as 'drift', these are the youngest geological deposits, formed during the Quaternary. They rest on older deposits or rocks referred to as bedrock.

Features are displayed on the Geology 1:50,000 scale - Superficial map on [page 85 >](#)

ID	Location	LEX Code	Description	Rock description
1	On site	RTD2-XSV	RIVER TERRACE DEPOSITS, 2	SAND AND GRAVEL
2	134m NW	ALV-XCZSV	ALLUVIUM	CLAY, SILT, SAND AND GRAVEL
3	198m NW	RTD2-XSV	RIVER TERRACE DEPOSITS, 2	SAND AND GRAVEL

This data is sourced from the British Geological Survey.



## 15.5 Superficial permeability (50k)

**Records within 50m** **1**

A qualitative classification of estimated rates of vertical movement of water from the ground surface through the unsaturated zone of any superficial deposits (the zone between the land surface and the water table).

Location	Flow type	Maximum permeability	Minimum permeability
On site	Intergranular	Very High	High

*This data is sourced from the British Geological Survey.*

## 15.6 Landslip (50k)

**Records within 500m** **0**

Mass movement deposits on BGS geological maps at 1:50,000 scale. Primarily superficial deposits that have moved down slope under gravity to form landslips. These affect bedrock, other superficial deposits and artificial ground.

*This data is sourced from the British Geological Survey.*

## 15.7 Landslip permeability (50k)

**Records within 50m** **0**

A qualitative classification of estimated rates of vertical movement of water from the ground surface through the unsaturated zone of any landslip deposits (the zone between the land surface and the water table).

*This data is sourced from the British Geological Survey.*

## Geology 1:50,000 scale - Bedrock

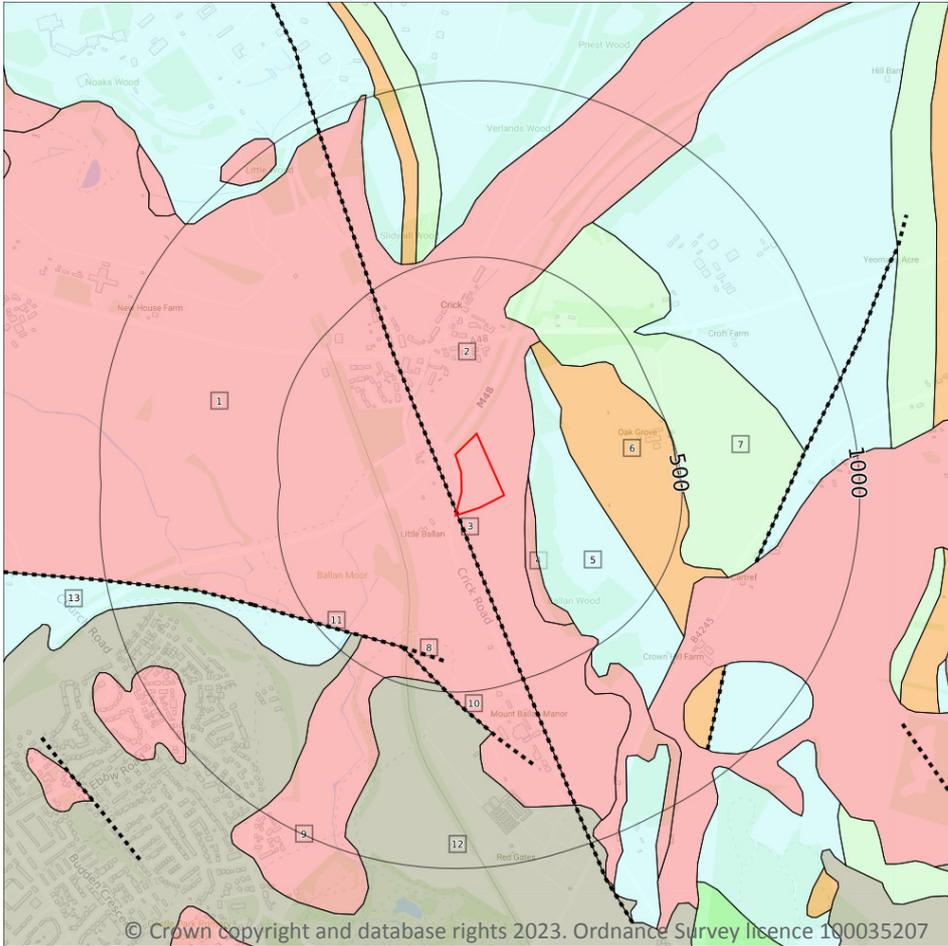

- Site Outline
- Search buffers in metres (m)
- .... Bedrock faults and other linear features (50k)
- Bedrock geology (50k)  
Please see table for more details.

### 15.8 Bedrock geology (50k)

Records within 500m

9

Bedrock geology at 1:50,000 scale. The main mass of rocks forming the Earth and present everywhere, whether exposed at the surface in outcrops or concealed beneath superficial deposits or water.

Features are displayed on the Geology 1:50,000 scale - Bedrock map on [page 87](#) >

ID	Location	LEX Code	Description	Rock age
1	On site	MMG-MDST	MERCIA MUDSTONE GROUP - MUDSTONE	-
2	On site	MMG-MDST	MERCIA MUDSTONE GROUP - MUDSTONE	-



ID	Location	LEX Code	Description	Rock age
4	60m E	MMMF-CONG	MERCIA MUDSTONE GROUP (MARGINAL FACIES) - CONGLOMERATE	-
5	76m E	HBO-LMOOL	HUNTS BAY OOLITE SUBGROUP - LIMESTONE, OOIDAL	WISEAN
6	217m E	CHSA-SDST	CROMHALL SANDSTONE FORMATION - SANDSTONE	WISEAN
7	308m NE	LLY-ARLMST	LLANELLY FORMATION - LIMESTONE/CEMENTSTONE/CALCILUTITE, ARGILLACEOUS, MUDDY	WISEAN
9	401m SW	MMG-MDST	MERCIA MUDSTONE GROUP - MUDSTONE	-
12	430m SW	MMG-SDST	MERCIA MUDSTONE GROUP - SANDSTONE	-
13	443m SW	HBO-LMOOL	HUNTS BAY OOLITE SUBGROUP - LIMESTONE, OOIDAL	WISEAN

This data is sourced from the British Geological Survey.

## 15.9 Bedrock permeability (50k)

Records within 50m

2

A qualitative classification of estimated rates of vertical movement of water from the ground surface through the unsaturated zone of bedrock (the zone between the land surface and the water table).

Location	Flow type	Maximum permeability	Minimum permeability
On site	Fracture	Low	Low
33m N	Fracture	Low	Low

This data is sourced from the British Geological Survey.

## 15.10 Bedrock faults and other linear features (50k)

Records within 500m

4

Linear features at the ground or bedrock surface at 1:50,000 scale of six main types; rock, fault, fold axis, mineral vein, alteration area or landform. Features are either observed or inferred, and relate primarily to bedrock.

Features are displayed on the Geology 1:50,000 scale - Bedrock map on [page 87 >](#)

ID	Location	Category	Description
3	On site	FAULT	Reverse or thrust fault, inferred



ID	Location	Category	Description
8	401m S	FAULT	Fault, inferred, displacement unknown
10	401m SW	FAULT	Fault, inferred, displacement unknown
11	401m SW	FAULT	Fault, inferred, displacement unknown

*This data is sourced from the British Geological Survey.*

## 16 Boreholes

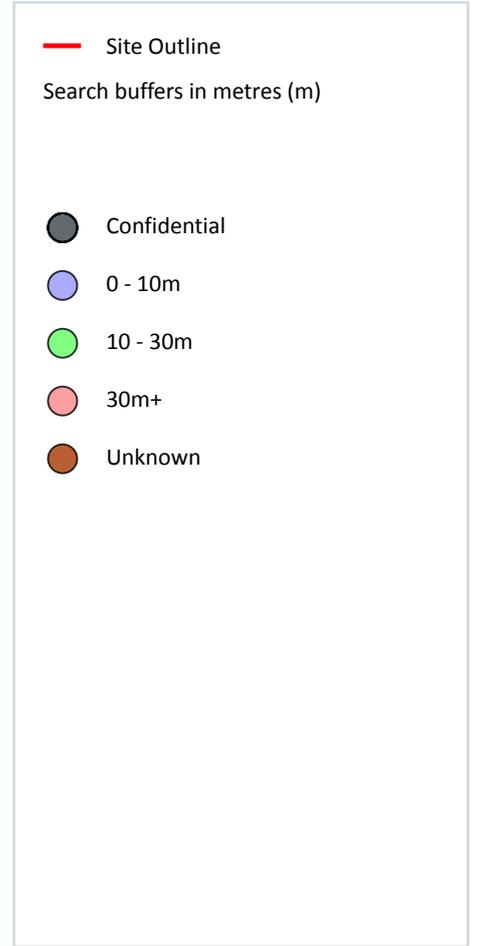

### 16.1 BGS Boreholes

Records within 250m

4

The Single Onshore Boreholes Index (SOBI); an index of over one million records of boreholes, shafts and wells from all forms of drilling and site investigation work held by the British Geological Survey. Covering onshore and nearshore boreholes dating back to at least 1790 and ranging from one to several thousand metres deep.

Features are displayed on the Boreholes map on [page 90](#) >

ID	Location	Grid reference	Name	Length	Confidential	Web link
1	28m NW	348927 189943	LONDON-SOUTH WALES MOTORWAY 95	6.24	N	<a href="#">16023736</a> ↗
2	139m N	349029 190100	LONDON-SOUTH WALES MOTORWAY 96	6.24	N	<a href="#">16023759</a> ↗

ID	Location	Grid reference	Name	Length	Confidential	Web link
3	219m W	348712 189737	LONDON-SOUTH WALES MOTORWAY 94	9.29	N	<a href="#">16023735</a> ↗
4	237m W	348698 189774	LONDON-SOUTH WALES MOTORWAY 93	9.14	N	<a href="#">16023734</a> ↗

*This data is sourced from the British Geological Survey.*

## 17 Natural ground subsidence - Shrink swell clays

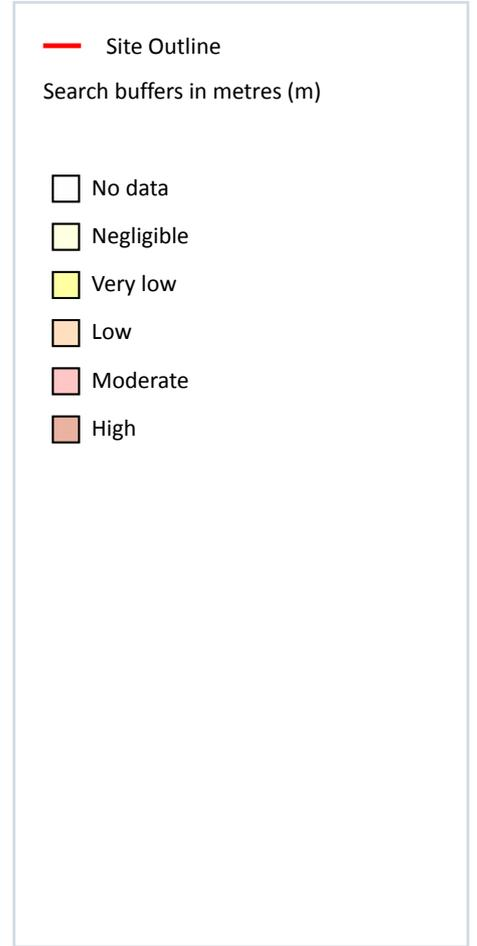
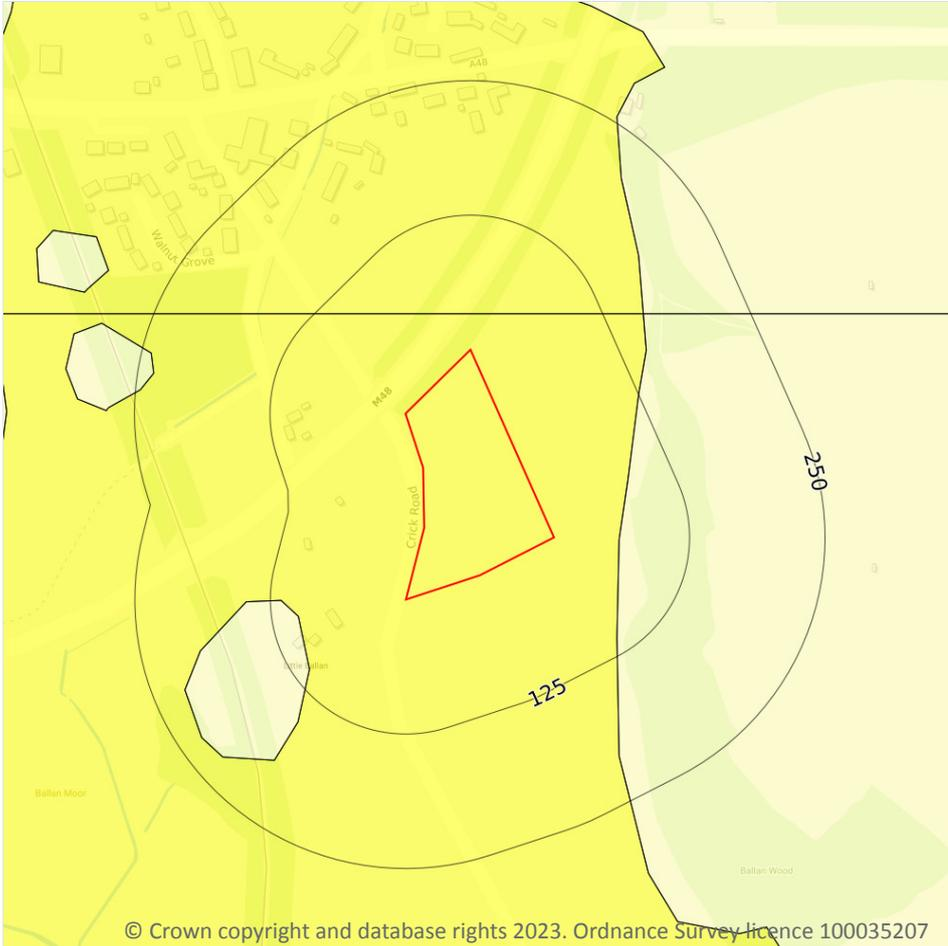

### 17.1 Shrink swell clays

Records within 50m

2

The potential hazard presented by soils that absorb water when wet (making them swell), and lose water as they dry (making them shrink). This shrink-swell behaviour is controlled by the type and amount of clay in the soil, and by seasonal changes in the soil moisture content (related to rainfall and local drainage).

Features are displayed on the Natural ground subsidence - Shrink swell clays map on [page 92 >](#)

Location	Hazard rating	Details
On site	Very low	Ground conditions predominantly low plasticity.
34m N	Very low	Ground conditions predominantly low plasticity.

*This data is sourced from the British Geological Survey.*

## Natural ground subsidence - Running sands

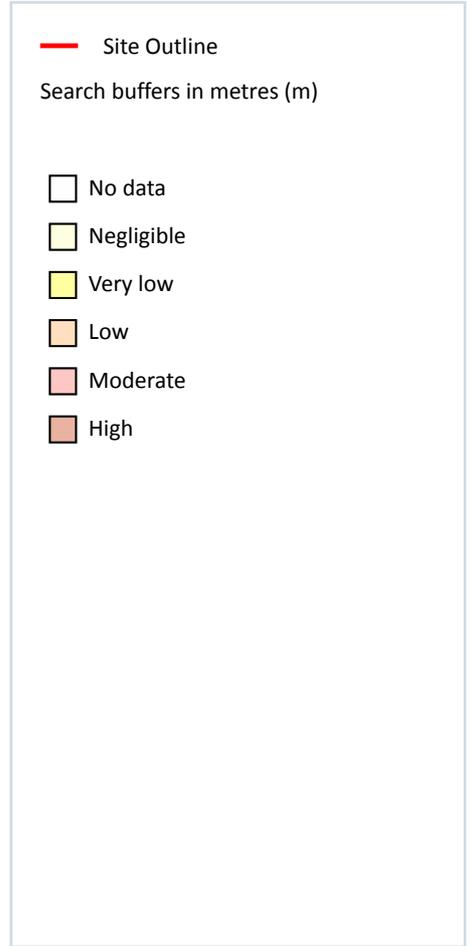
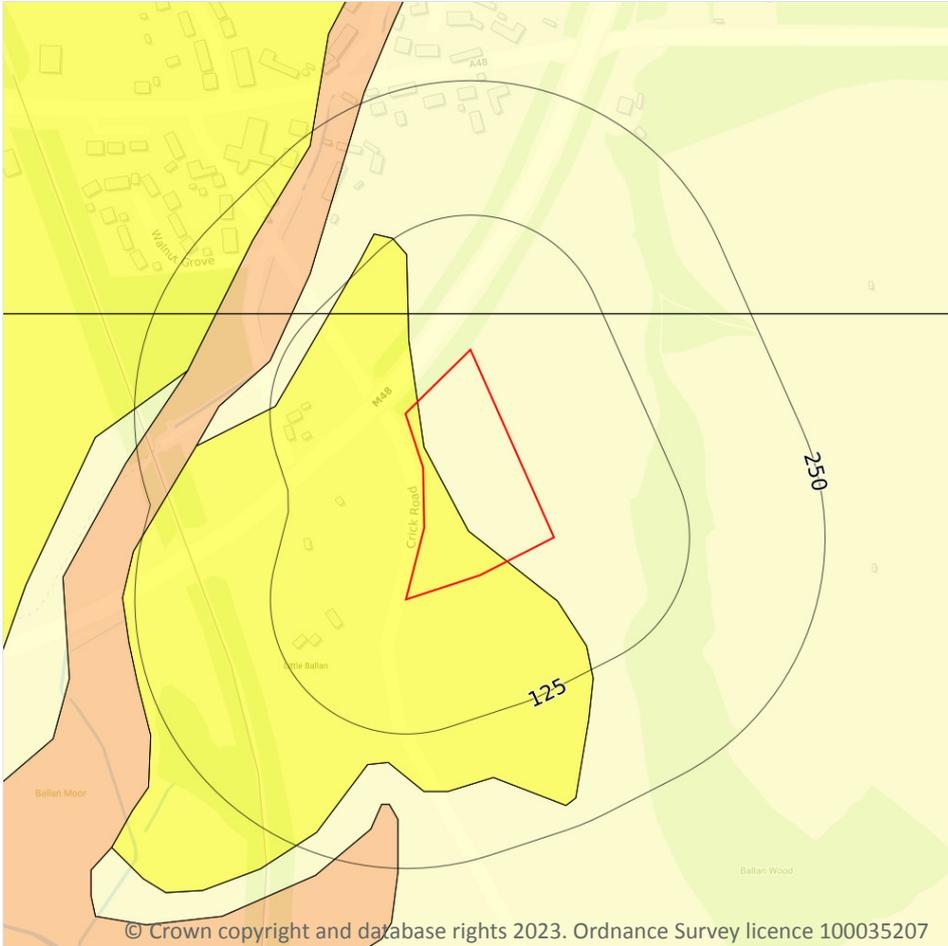

### 17.2 Running sands

Records within 50m

3

The potential hazard presented by rocks that can contain loosely-packed sandy layers that can become fluidised by water flowing through them. Such sands can 'run', removing support from overlying buildings and causing potential damage.

Features are displayed on the Natural ground subsidence - Running sands map on [page 93](#) >

Location	Hazard rating	Details
On site	Negligible	Running sand conditions are not thought to occur whatever the position of the water table. No identified constraints on lands use due to running conditions.

Location	Hazard rating	Details
On site	Very low	Running sand conditions are unlikely. No identified constraints on land use due to running conditions unless water table rises rapidly.
34m N	Negligible	Running sand conditions are not thought to occur whatever the position of the water table. No identified constraints on lands use due to running conditions.

*This data is sourced from the British Geological Survey.*

## Natural ground subsidence - Compressible deposits

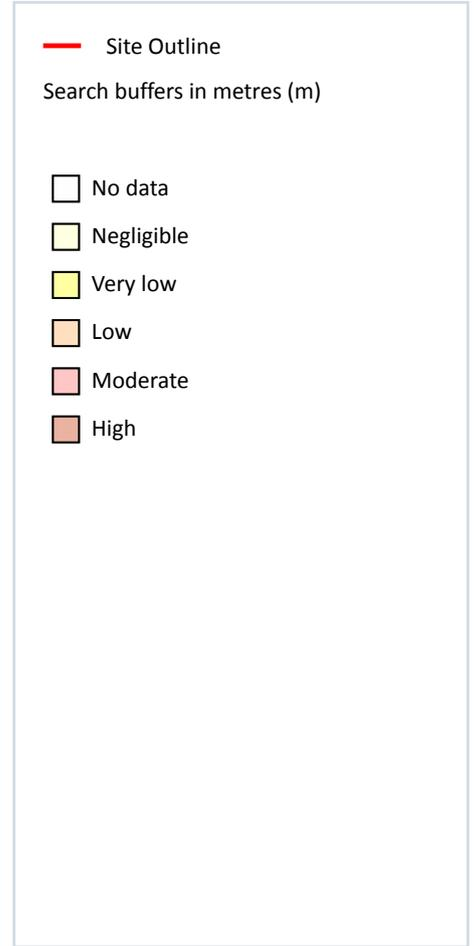
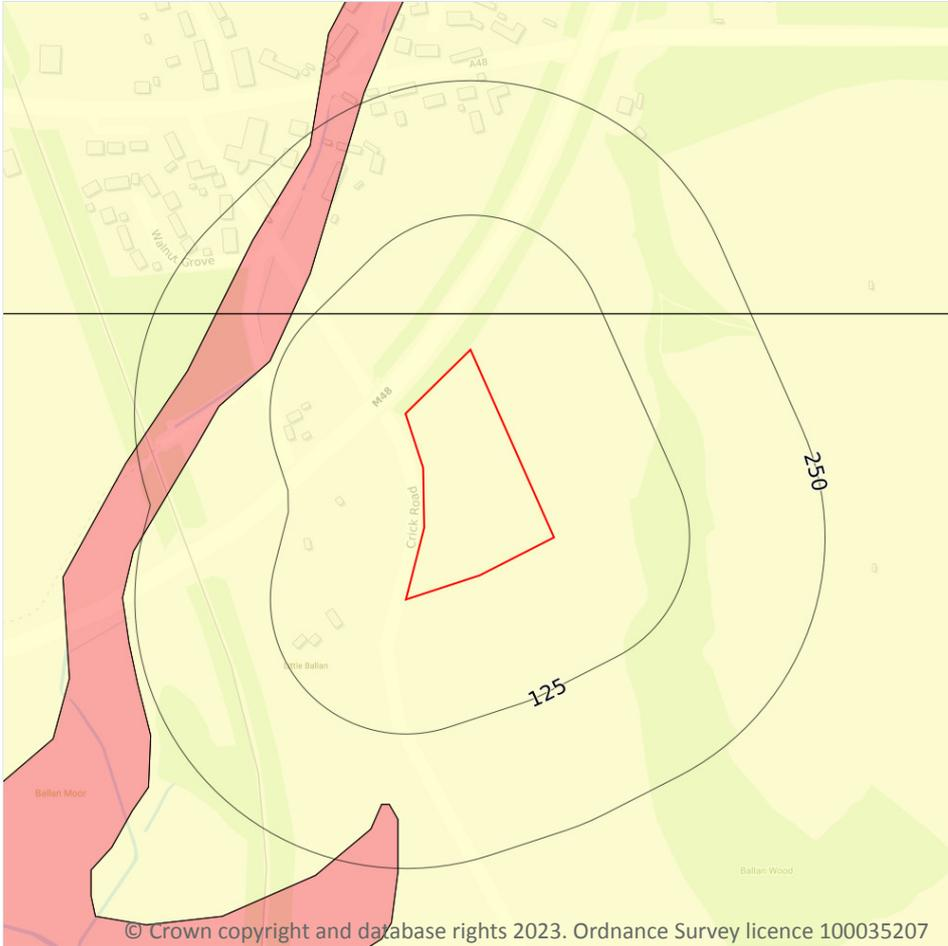

### 17.3 Compressible deposits

Records within 50m

2

The potential hazard presented by types of ground that may contain layers of very soft materials like clay or peat and may compress if loaded by overlying structures, or if the groundwater level changes, potentially resulting in depression of the ground and disturbance of foundations.

Features are displayed on the Natural ground subsidence - Compressible deposits map on [page 95 >](#)

Location	Hazard rating	Details
On site	Negligible	Compressible strata are not thought to occur.
34m N	Negligible	Compressible strata are not thought to occur.

*This data is sourced from the British Geological Survey.*



## Natural ground subsidence - Collapsible deposits

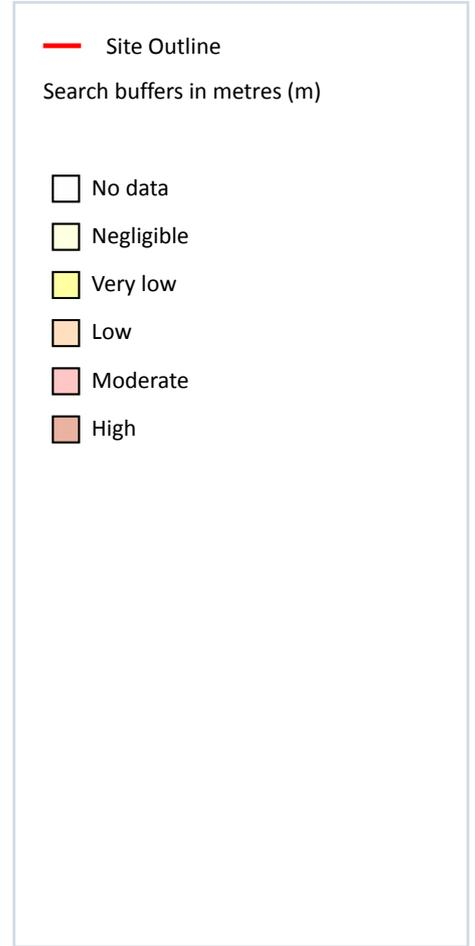
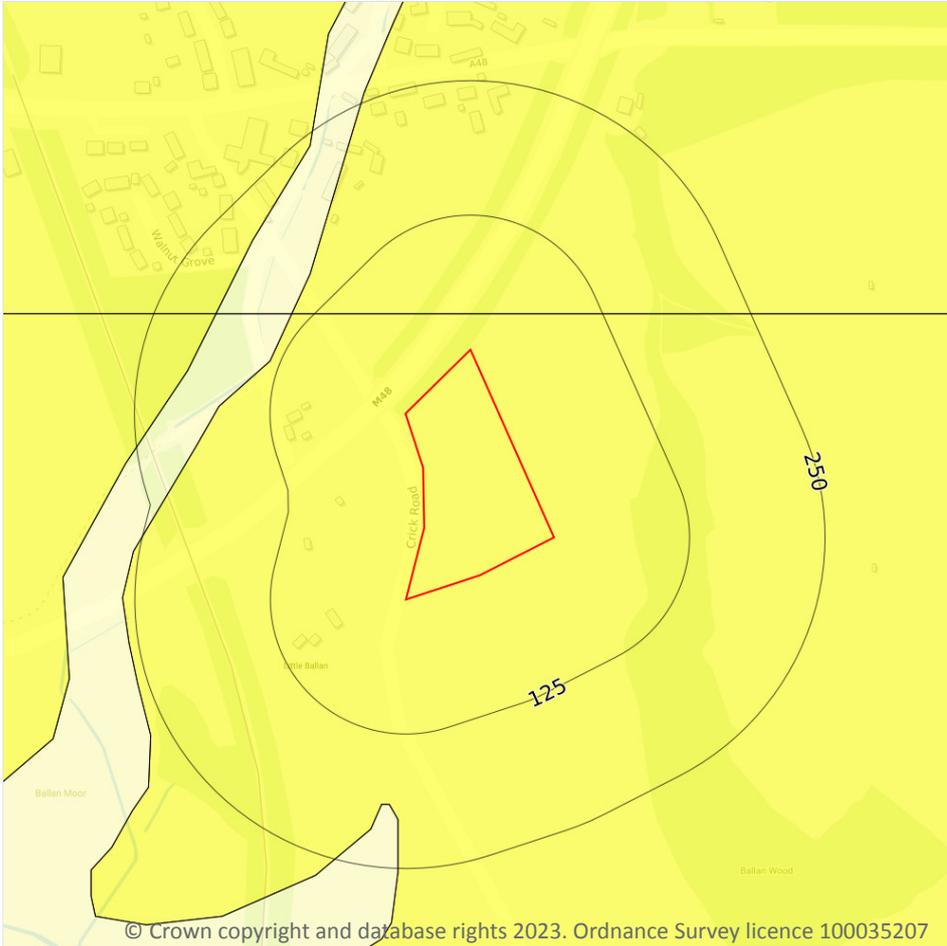

### 17.4 Collapsible deposits

Records within 50m

2

The potential hazard presented by natural deposits that could collapse when a load (such as a building) is placed on them or they become saturated with water.

Features are displayed on the Natural ground subsidence - Collapsible deposits map on [page 96 >](#)

Location	Hazard rating	Details
On site	Very low	Deposits with potential to collapse when loaded and saturated are unlikely to be present.
34m N	Very low	Deposits with potential to collapse when loaded and saturated are unlikely to be present.

*This data is sourced from the British Geological Survey.*

## Natural ground subsidence - Landslides

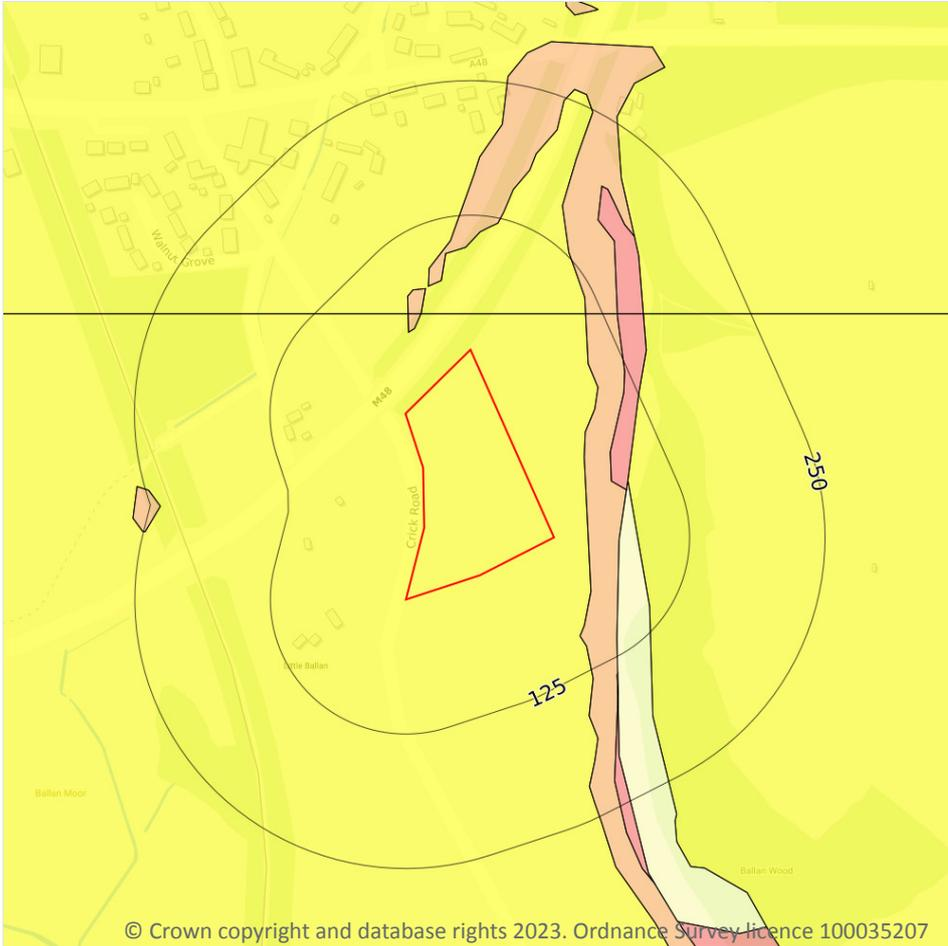

— Site Outline  
Search buffers in metres (m)

- No data
- Negligible
- Very low
- Low
- Moderate
- High

### 17.5 Landslides

Records within 50m

3

The potential for landsliding (slope instability) to be a hazard assessed using 1:50,000 scale digital maps of superficial and bedrock deposits, combined with information from the BGS National Landslide Database and scientific and engineering reports.

Features are displayed on the Natural ground subsidence - Landslides map on [page 97 >](#)

Location	Hazard rating	Details
On site	Very low	Slope instability problems are not likely to occur but consideration to potential problems of adjacent areas impacting on the site should always be considered.

Location	Hazard rating	Details
32m SE	Low	Slope instability problems may be present or anticipated. Site investigation should consider specifically the slope stability of the site.
34m N	Very low	Slope instability problems are not likely to occur but consideration to potential problems of adjacent areas impacting on the site should always be considered.

*This data is sourced from the British Geological Survey.*



## Natural ground subsidence - Ground dissolution of soluble rocks

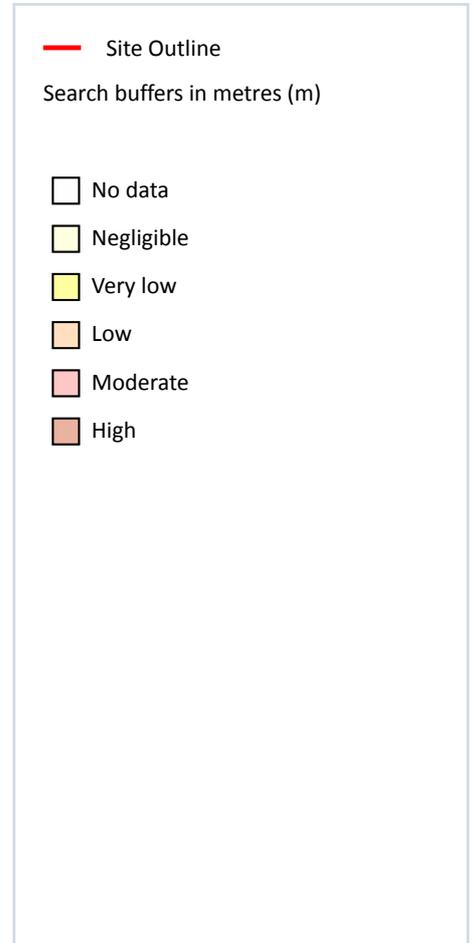
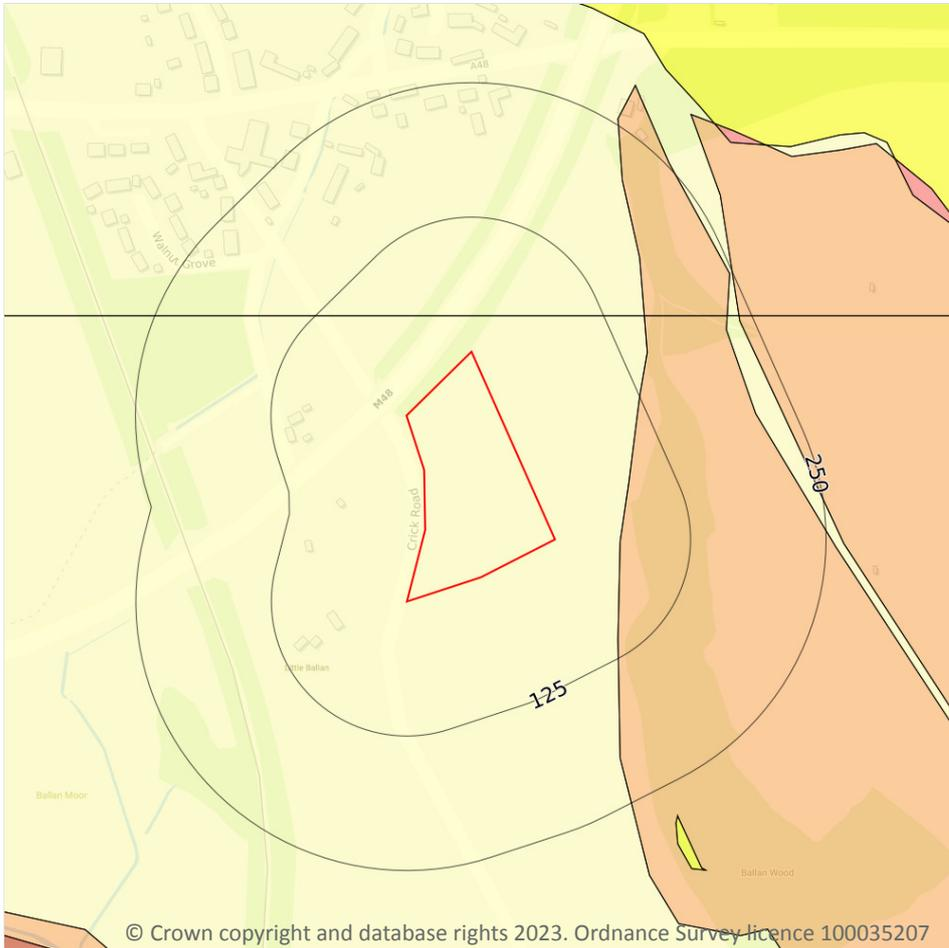

### 17.6 Ground dissolution of soluble rocks

Records within 50m

2

The potential hazard presented by ground dissolution, which occurs when water passing through soluble rocks produces underground cavities and cave systems. These cavities reduce support to the ground above and can cause localised collapse of the overlying rocks and deposits.

Features are displayed on the Natural ground subsidence - Ground dissolution of soluble rocks map on [page 99](#)

Location	Hazard rating	Details
On site	Negligible	Soluble rocks are either not thought to be present within the ground, or not prone to dissolution. Dissolution features are unlikely to be present.

Location	Hazard rating	Details
34m N	Negligible	Soluble rocks are either not thought to be present within the ground, or not prone to dissolution. Dissolution features are unlikely to be present.

*This data is sourced from the British Geological Survey.*

## 18 Mining and ground workings

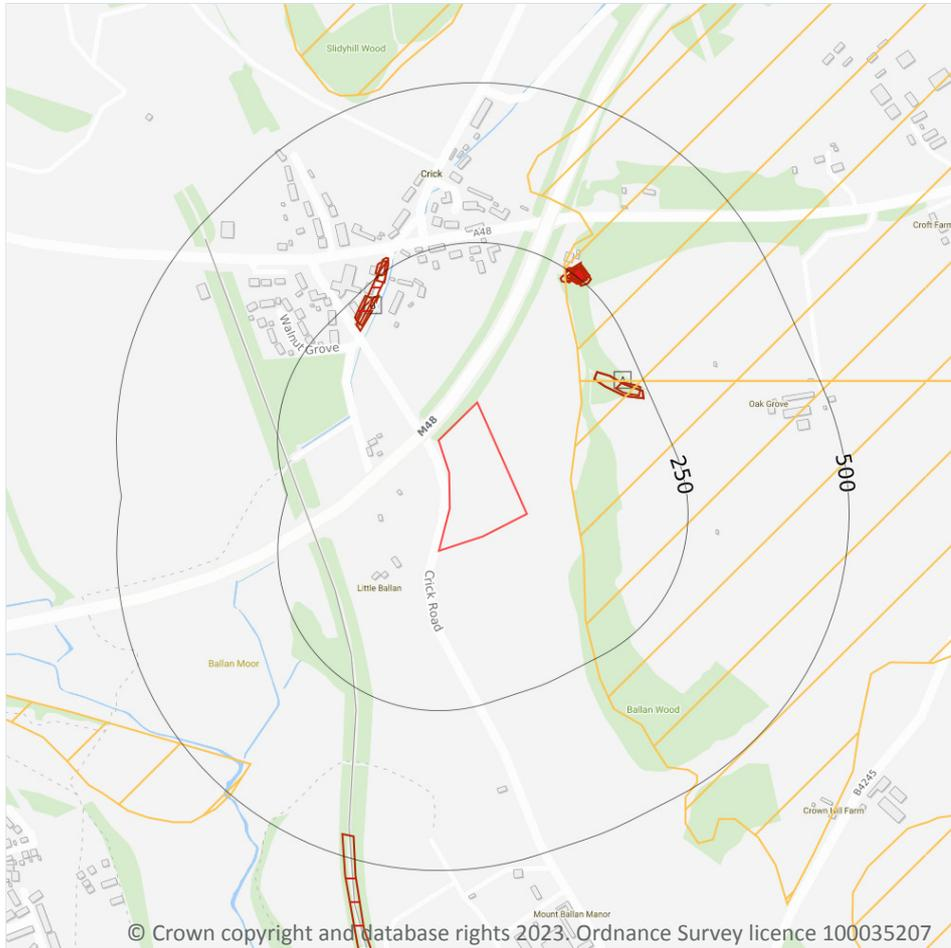

### 18.1 BritPits

Records within 500m

1

BritPits (an abbreviation of British Pits) is a database maintained by the British Geological Survey of currently active and closed surface and underground mineral workings. Details of major mineral handling sites, such as wharfs and rail depots are also held in the database.

Features are displayed on the Mining and ground workings map on [page 101](#) >

ID	Location	Details	Description
C	253m NE	Name: Hill Barn Address: Crick, NEWPORT, Monmouthshire Commodity: Limestone Status: Ceased	Type: A surface mineral working. It may be termed Quarry, Sand Pit, Clay Pit or Opencast Coal Site Status description: Site which, at date of entry, has ceased to extract minerals. May be considered as Closed by operator. May be considered to have Active, Dormant or Expired planning permissions by Mineral Planning Authority

This data is sourced from the British Geological Survey.

## 18.2 Surface ground workings

<b>Records within 250m</b>	<b>14</b>
----------------------------	-----------

Historical land uses identified from Ordnance Survey mapping that involved ground excavation at the surface. These features may or may not have been subsequently backfilled.

Features are displayed on the Mining and ground workings map on [page 101 >](#)

ID	Location	Land Use	Year of mapping	Mapping scale
A	181m NE	Cuttings	1949	1:10560
A	181m NE	Cuttings	1919	1:10560
A	206m NE	Cuttings	1949	1:10560
B	207m NW	Unspecified Pit	1919	1:10560
B	211m NW	Unspecified Pit	1949	1:10560
B	216m NW	Unspecified Pit	1949	1:10560
C	230m NE	Unspecified Old Quarry	1902	1:10560
C	236m NE	Unspecified Old Quarry	1949	1:10560
C	236m NE	Unspecified Old Quarry	1919	1:10560
B	236m NW	Unspecified Pit	1919	1:10560
C	240m NE	Unspecified Old Quarry	1949	1:10560
C	240m NE	Unspecified Old Quarry	1967	1:10000
C	240m NE	Unspecified Old Quarry	1968	1:10560
B	247m NW	Unspecified Pit	1949	1:10560

This data is sourced from Ordnance Survey/Groundsure.



### 18.3 Underground workings

Records within 1000m

0

Historical land uses identified from Ordnance Survey mapping that indicate the presence of underground workings e.g. mine shafts.

*This is data is sourced from Ordnance Survey/Groundsure.*

### 18.4 Underground mining extents

Records within 500m

0

This data identifies underground mine workings that could present a potential risk, including adits and seam workings. These features have been identified from BGS Geological mapping and mine plans sourced from the BGS and various collections and sources.

*This data is sourced from Groundsure.*

### 18.5 Historical Mineral Planning Areas

Records within 500m

0

Boundaries of mineral planning permissions for England and Wales. This data was collated between the 1940s (and retrospectively to the 1930s) and the mid 1980s. The data includes permitted, withdrawn and refused permissions.

*This data is sourced from the British Geological Survey.*

### 18.6 Non-coal mining

Records within 1000m

9

The potential for historical non-coal mining to have affected an area. The assessment is drawn from expert knowledge and literature in addition to the digital geological map of Britain. Mineral commodities may be divided into seven general categories - vein minerals, chalk, oil shale, building stone, bedded ores, evaporites and 'other' commodities (including ball clay, jet, black marble, graphite and chert).

Features are displayed on the Mining and ground workings map on [page 101](#) >

ID	Location	Name	Commodity	Class	Likelihood
1	76m E	Not available	Vein Mineral	B	Underground mine workings may have occurred in the past or current mines may be working at significant depth to modern engineering standards. Potential for difficult ground conditions are unlikely and are at a level where they need not be considered.



ID	Location	Name	Commodity	Class	Likelihood
2	159m NE	Not available	Vein Mineral	B	Underground mine workings may have occurred in the past or current mines may be working at significant depth to modern engineering standards. Potential for difficult ground conditions are unlikely and are at a level where they need not be considered.
3	443m SW	Not available	Vein Mineral	B	Underground mine workings may have occurred in the past or current mines may be working at significant depth to modern engineering standards. Potential for difficult ground conditions are unlikely and are at a level where they need not be considered.
5	512m N	Not available	Vein Mineral	B	Underground mine workings may have occurred in the past or current mines may be working at significant depth to modern engineering standards. Potential for difficult ground conditions are unlikely and are at a level where they need not be considered.
6	765m SE	Not available	Vein Mineral	B	Underground mine workings may have occurred in the past or current mines may be working at significant depth to modern engineering standards. Potential for difficult ground conditions are unlikely and are at a level where they need not be considered.
-	816m SE	Not available	Vein Mineral	B	Underground mine workings may have occurred in the past or current mines may be working at significant depth to modern engineering standards. Potential for difficult ground conditions are unlikely and are at a level where they need not be considered.
-	935m E	Not available	Vein Mineral	B	Underground mine workings may have occurred in the past or current mines may be working at significant depth to modern engineering standards. Potential for difficult ground conditions are unlikely and are at a level where they need not be considered.
-	955m E	Not available	Vein Mineral	B	Underground mine workings may have occurred in the past or current mines may be working at significant depth to modern engineering standards. Potential for difficult ground conditions are unlikely and are at a level where they need not be considered.
-	974m SE	Not available	Vein Mineral	B	Underground mine workings may have occurred in the past or current mines may be working at significant depth to modern engineering standards. Potential for difficult ground conditions are unlikely and are at a level where they need not be considered.

*This data is sourced from the British Geological Survey.*



## 18.7 JPB mining areas

Records on site

0

Areas which could be affected by former coal and other mining. This data includes some mine plans unavailable to the Coal Authority.

*This data is sourced from Johnson Poole and Bloomer.*

## 18.8 The Coal Authority non-coal mining

Records within 500m

0

This data provides an indication of the potential zone of influence of recorded underground non-coal mining workings. Any and all analysis and interpretation of Coal Authority Data in this report is made by Groundsure, and is in no way supported, endorsed or authorised by the Coal Authority. The use of the data is restricted to the terms and provisions contained in this report. Data reproduced in this report may be the copyright of the Coal Authority and permission should be sought from Groundsure prior to any re-use.

*This data is sourced from The Coal Authority.*

## 18.9 Researched mining

Records within 500m

0

This data indicates areas of potential mining identified from alternative or archival sources, including; BGS Geological paper maps, Lidar data, aerial photographs (from World War II onwards), archaeological data services, websites, Tithe maps, and various text/plans from collected books and reports. Some of this data is approximate and Groundsure have interpreted the resultant risk area and, where possible, specific areas of risk have been captured.

*This data is sourced from Groundsure.*

## 18.10 Mining record office plans

Records within 500m

0

This dataset is representative of Mining Record Office and/or plan extents held by Groundsure and should be considered approximate. Where possible, plans have been located and any specific areas of risk they depict have been captured.

*This data is sourced from Groundsure.*

### 18.11 BGS mine plans

Records within 500m

0

This dataset is representative of BGS mine plans held by Groundsure and should be considered approximate. Where possible, plans have been located and any specific areas of risk they depict have been captured.

*This data is sourced from Groundsure.*

### 18.12 Coal mining

Records on site

0

Areas which could be affected by past, current or future coal mining.

*This data is sourced from the Coal Authority.*

### 18.13 Brine areas

Records on site

0

The Cheshire Brine Compensation District indicates areas that may be affected by salt and brine extraction in Cheshire and where compensation would be available where damage from this mining has occurred. Damage from salt and brine mining can still occur outside this district, but no compensation will be available.

*This data is sourced from the Cheshire Brine Subsidence Compensation Board.*

### 18.14 Gypsum areas

Records on site

0

Generalised areas that may be affected by gypsum extraction.

*This data is sourced from British Gypsum.*

### 18.15 Tin mining

Records on site

0

Generalised areas that may be affected by historical tin mining.

*This data is sourced from Groundsure.*

## 18.16 Clay mining

Records on site

0

Generalised areas that may be affected by kaolin and ball clay extraction.

*This data is sourced from the Kaolin and Ball Clay Association (UK).*



## 19 Ground cavities and sinkholes

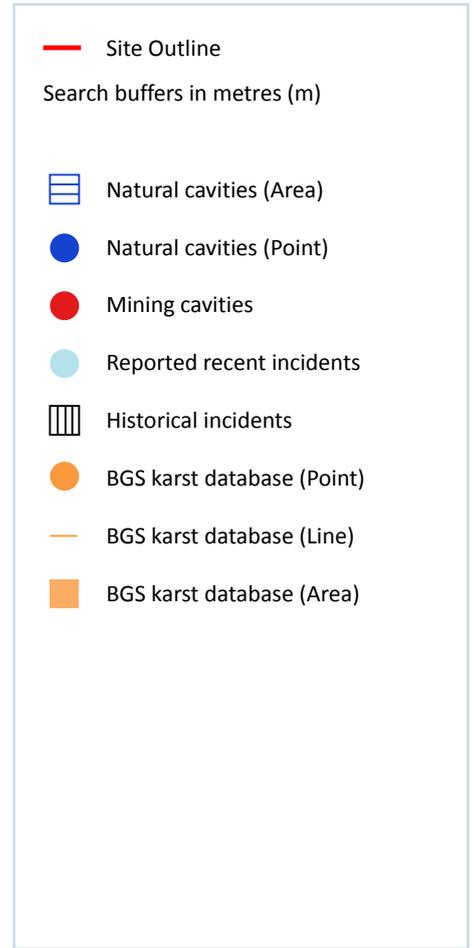
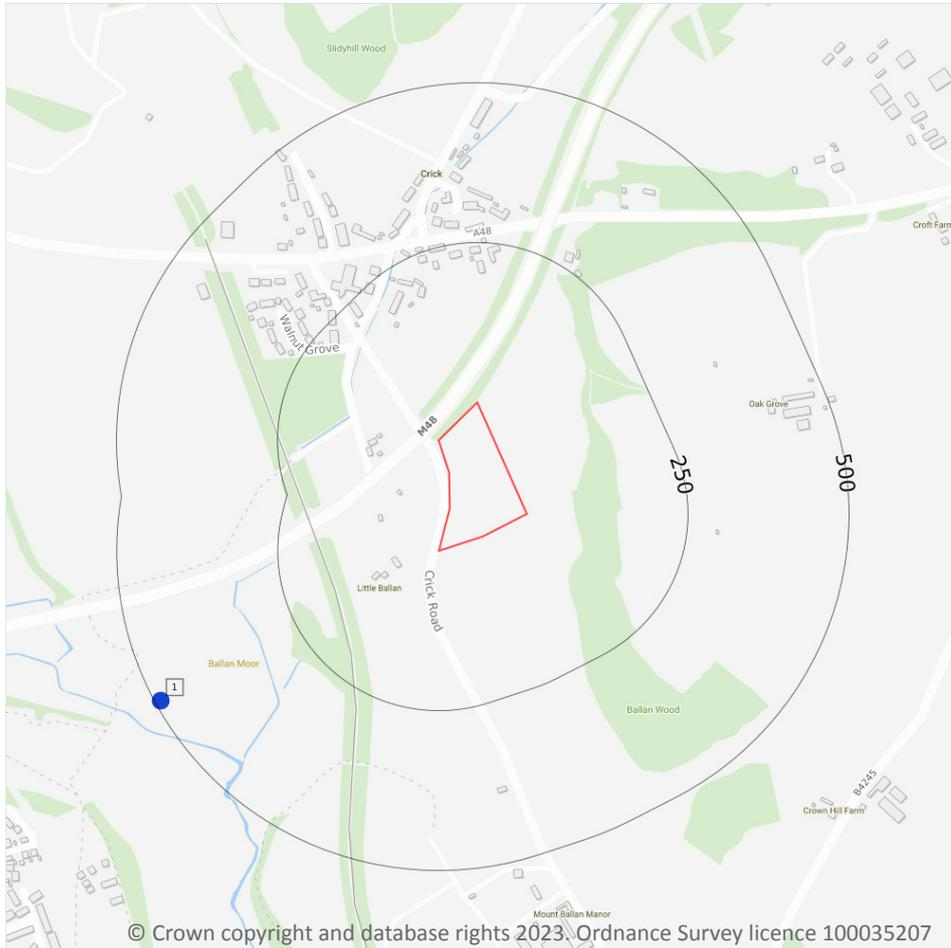

### 19.1 Natural cavities

Records within 500m

1

Industry recognised national database of natural cavities. Sinkholes and caves are formed by the dissolution of soluble rock, such as chalk and limestone, gulls and fissures by cambering. Ground instability can result from movement of loose material contained within these cavities, often triggered by water.

Features are displayed on the Ground cavities and sinkholes map on [page 108](#) >

ID	Location	Details	Source
1	490m SW	Type: - Superficial Geology: - Bedrock Geology: Lower Carboniferous Limestone	Simple Bibliography: - Full Bibliography: Unknown Author, ; Confidentiality: Data source can be revealed, data can be used freely

*This data is sourced from Stantec UK Ltd.*

## 19.2 Mining cavities

**Records within 1000m**

**0**

Industry recognised national database of mining cavities. Degraded mines may result in hazardous subsidence (crown holes). Climatic conditions and water escape can also trigger subsidence over mine entrances and workings.

*This data is sourced from Stantec UK Ltd.*

## 19.3 Reported recent incidents

**Records within 500m**

**0**

This data identifies sinkhole information gathered from media reports and Groundsure's own records. This data goes back to 2014 and includes relative accuracy ratings for each event and links to the original data sources. The data is updated on a regular basis and should not be considered a comprehensive catalogue of all sinkhole events. The absence of data in this database does not mean a sinkhole definitely has not occurred during this time.

*This data is sourced from Groundsure.*

## 19.4 Historical incidents

**Records within 500m**

**0**

This dataset comprises an extract of 1:10,560, 1:10,000, 1:2,500 and 1:1,250 scale historical Ordnance Survey maps held by Groundsure, dating back to the 1840s. It shows shakeholes, deneholes and other 'holes' as noted on these maps. Dene holes are medieval chalk extraction pits, usually comprising a narrow shaft with a number of chambers at the base of the shaft. Shakeholes are an alternative name for suffusion sinkholes, most commonly found in the limestone landscapes of North Yorkshire but also extensively noted around the Brecon Beacons National Park.

Not all 'holes' noted on Ordnance Survey mapping will necessarily be present within this dataset.

*This data is sourced from Groundsure.*

## 19.5 National karst database

**Records within 500m**

**0**

This is a comprehensive database of national karst information gathered from a wide range of sources. BGS have collected data on five main types of karst feature: Sinkholes, stream links, caves, springs, and incidences of associated damage to buildings, roads, bridges and other engineered works.

Since the database was set up in 2002 data covering most of the evaporite karst areas of the UK have now



been added, along with data covering about 60% of the Chalk, and 35% of the Carboniferous Limestone outcrops. Many of the classic upland karst areas have yet to be included. Recorded so far are: Over 800 caves, 1300 stream sinks, 5600 springs, 10,000 sinkholes.

The database is not yet complete, and not all records have been verified. The absence of data does not mean that karst features are not present at a site. A reliability rating is included with each record.

*This data is sourced from the British Geological Survey.*



## 20 Radon

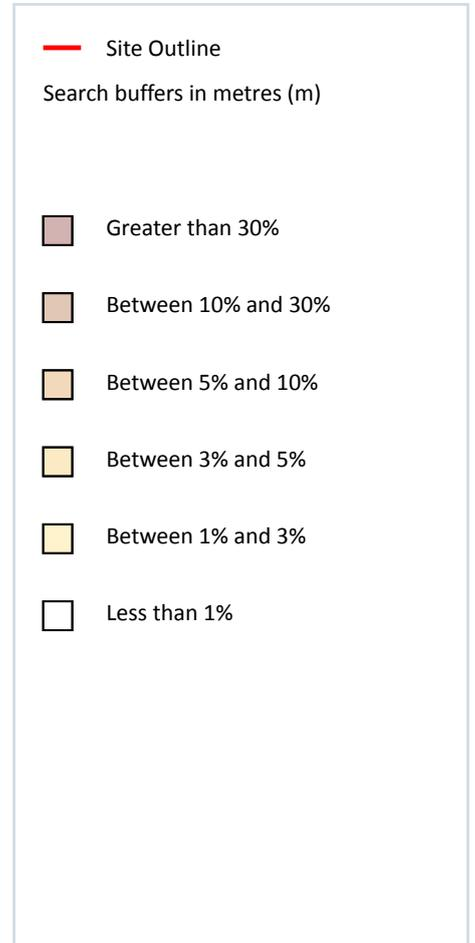
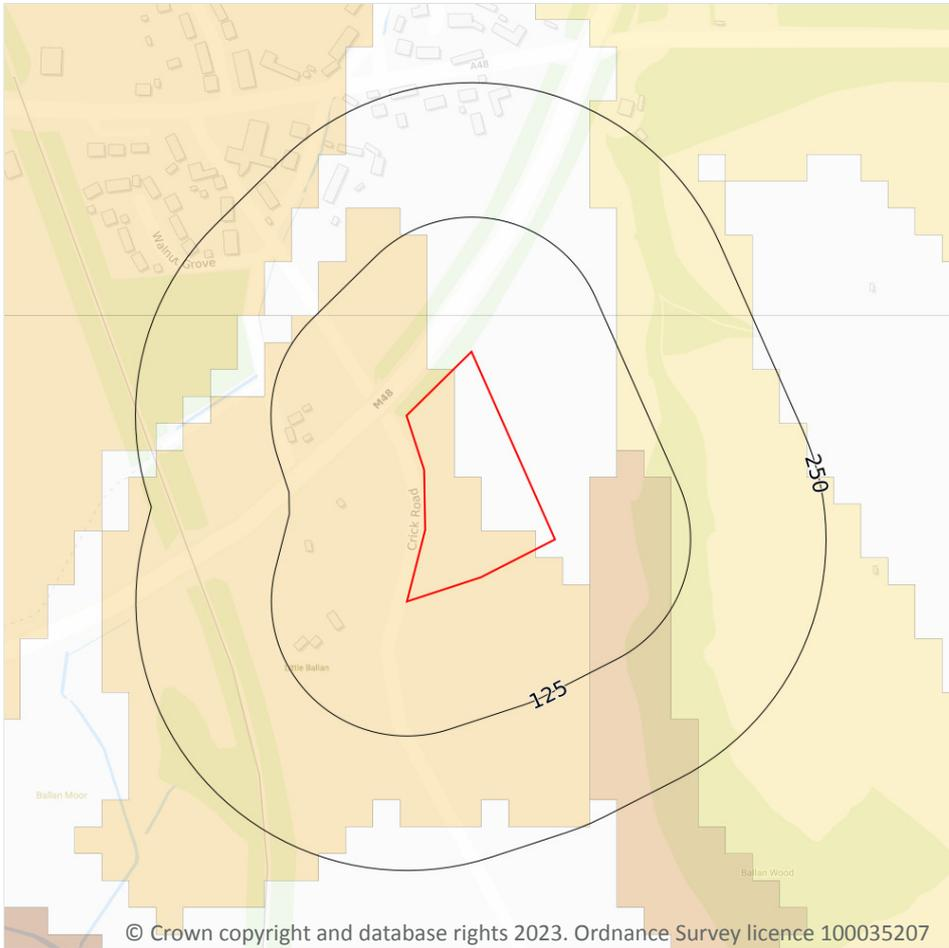

### 20.1 Radon

#### Records on site

2

The Radon Potential data classifies areas based on their likelihood of a property having a radon level at or above the Action Level in Great Britain. The dataset is intended for use at 1:50,000 scale and was derived from both geological assessments and indoor radon measurements (more than 560,000 records). A minimum 50m buffer should be considered when searching the maps, as the smallest detectable feature at this scale is 50m. The findings of this section should supersede any estimations derived from the Indicative Atlas of Radon in Great Britain (1:100,000 scale).

Features are displayed on the Radon map on [page 111 >](#)

Location	Estimated properties affected	Radon Protection Measures required
On site	Less than 1%	None



Location	Estimated properties affected	Radon Protection Measures required
<b>On site</b>	<b>Between 3% and 5%</b>	<b>Basic</b>

*This data is sourced from the British Geological Survey and UK Health Security Agency.*



## 21 Soil chemistry

### 21.1 BGS Estimated Background Soil Chemistry

Records within 50m

10

The estimated values provide the likely background concentration of the potentially harmful elements Arsenic, Cadmium, Chromium, Lead and Nickel in topsoil. The values are estimated primarily from rural topsoil data collected at a sample density of approximately 1 per 2 km<sup>2</sup>. In areas where rural soil samples are not available, estimation is based on stream sediment data collected from small streams at a sampling density of 1 per 2.5 km<sup>2</sup>; this is the case for most of Scotland, Wales and southern England. The stream sediment data are converted to soil-equivalent concentrations prior to the estimation.

Location	Arsenic	Bioaccessible Arsenic	Lead	Bioaccessible Lead	Cadmium	Chromium	Nickel
On site	15 - 25 mg/kg	No data	100 mg/kg	60 mg/kg	1.8 mg/kg	60 - 90 mg/kg	15 - 30 mg/kg
On site	15 - 25 mg/kg	No data	100 mg/kg	60 mg/kg	1.8 mg/kg	60 - 90 mg/kg	15 - 30 mg/kg
On site	15 - 25 mg/kg	No data	100 mg/kg	60 mg/kg	1.8 mg/kg	60 - 90 mg/kg	15 - 30 mg/kg
On site	15 mg/kg	No data	100 mg/kg	60 mg/kg	1.8 mg/kg	60 - 90 mg/kg	15 - 30 mg/kg
On site	15 mg/kg	No data	100 mg/kg	60 mg/kg	1.8 mg/kg	60 - 90 mg/kg	15 - 30 mg/kg
On site	15 mg/kg	No data	100 mg/kg	60 mg/kg	1.8 mg/kg	60 - 90 mg/kg	15 - 30 mg/kg
On site	15 mg/kg	No data	100 mg/kg	60 mg/kg	1.8 mg/kg	60 - 90 mg/kg	15 - 30 mg/kg
33m N	15 - 25 mg/kg	No data	100 mg/kg	60 mg/kg	1.8 mg/kg	60 - 90 mg/kg	15 - 30 mg/kg
35m N	15 - 25 mg/kg	No data	100 mg/kg	60 mg/kg	1.8 mg/kg	60 - 90 mg/kg	15 - 30 mg/kg
35m N	15 - 25 mg/kg	No data	100 mg/kg	60 mg/kg	1.8 mg/kg	60 - 90 mg/kg	15 - 30 mg/kg

*This data is sourced from the British Geological Survey.*



## 21.2 BGS Estimated Urban Soil Chemistry

Records within 50m

0

Estimated topsoil chemistry of Arsenic, Cadmium, Chromium, Copper, Nickel, Lead, Tin and Zinc and bioaccessible Arsenic and Lead in 23 urban centres across Great Britain. These estimates are derived from interpolation of the measured urban topsoil data referred to above and provide information across each city between the measured sample locations (4 per km<sup>2</sup>).

*This data is sourced from the British Geological Survey.*

## 21.3 BGS Measured Urban Soil Chemistry

Records within 50m

0

The locations and measured total concentrations (mg/kg) of Arsenic, Cadmium, Chromium, Copper, Nickel, Lead, Tin and Zinc in urban topsoil samples from 23 urban centres across Great Britain. These are collected at a sample density of 4 per km<sup>2</sup>.

*This data is sourced from the British Geological Survey.*



## 22 Railway infrastructure and projects

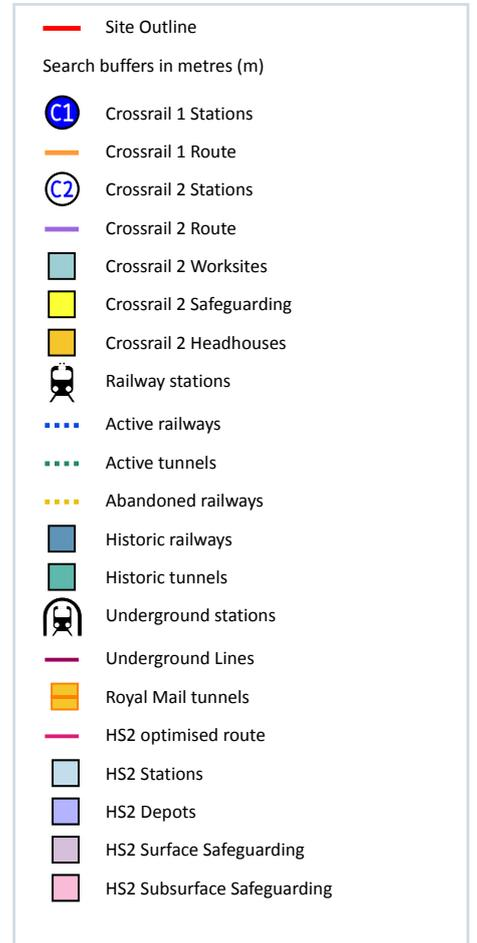
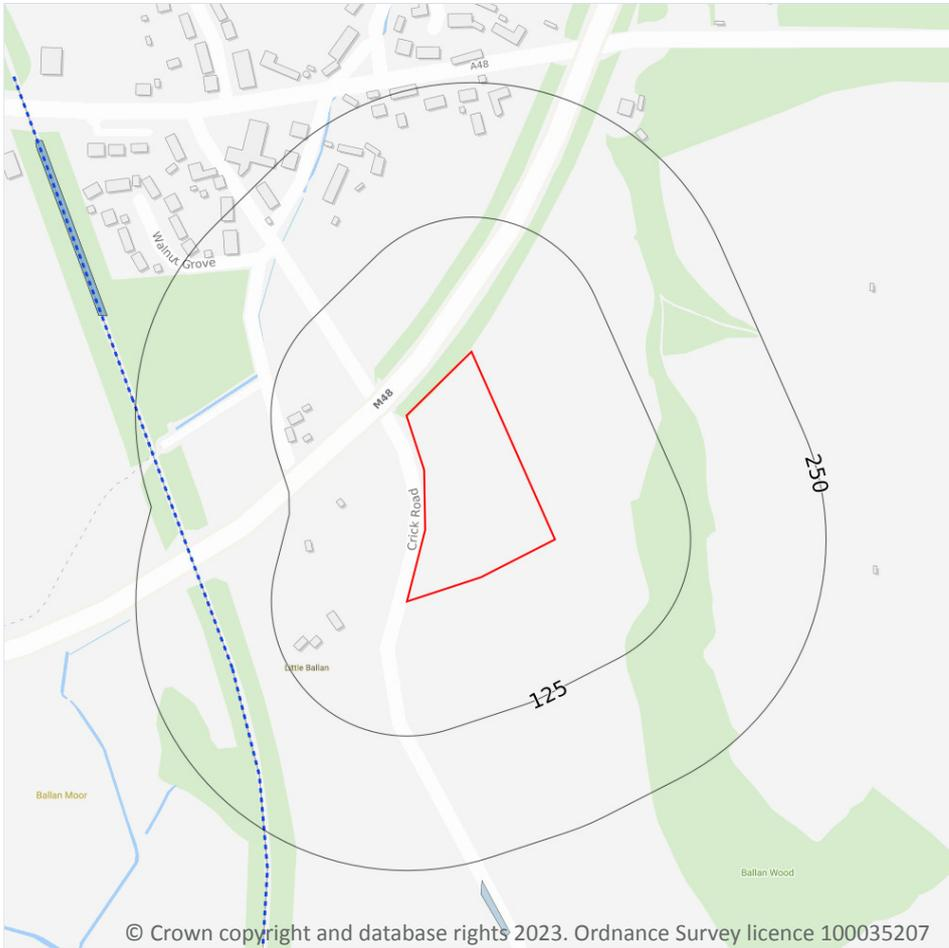

### 22.1 Underground railways (London)

Records within 250m

0

Details of all active London Underground lines, including approximate tunnel roof depth and operational hours.

*This data is sourced from publicly available information by Groundsure.*

### 22.2 Underground railways (Non-London)

Records within 250m

0

Details of the Merseyrail system, the Tyne and Wear Metro and the Glasgow Subway. Not all parts of all systems are located underground. The data contains location information only and does not include a depth assessment.

*This data is sourced from publicly available information by Groundsure.*

## 22.3 Railway tunnels

Records within 250m

0

Railway tunnels taken from contemporary Ordnance Survey mapping.

*This data is sourced from the Ordnance Survey.*

## 22.4 Historical railway and tunnel features

Records within 250m

0

Railways and tunnels digitised from historical Ordnance Survey mapping as scales of 1:1,250, 1:2,500, 1:10,000 and 1:10,560.

*This data is sourced from Ordnance Survey/Groundsure.*

## 22.5 Royal Mail tunnels

Records within 250m

0

The Post Office Railway, otherwise known as the Mail Rail, is an underground railway running through Central London from Paddington Head District Sorting Office to Whitechapel Eastern Head Sorting Office. The line is 10.5km long. The data includes details of the full extent of the tunnels, the depth of the tunnel, and the depth to track level.

*This data is sourced from Groundsure/the Postal Museum.*

## 22.6 Historical railways

Records within 250m

0

Former railway lines, including dismantled lines, abandoned lines, disused lines, historic railways and razed lines.

*This data is sourced from OpenStreetMap.*

## 22.7 Railways

Records within 250m

3

Currently existing railway lines, including standard railways, narrow gauge, funicular, trams and light railways. Features are displayed on the Railway infrastructure and projects map on [page 115 >](#)



Location	Name	Type
173m SW	Not given	Single Track
173m SW	Not given	Single Track
229m W	Not given	Single Track

*This data is sourced from Ordnance Survey and OpenStreetMap.*

## 22.8 Crossrail 1

**Records within 500m**

**0**

The Crossrail railway project links 41 stations over 100 kilometres from Reading and Heathrow in the west, through underground sections in central London, to Shenfield and Abbey Wood in the east.

*This data is sourced from publicly available information by Groundsure.*

## 22.9 Crossrail 2

**Records within 500m**

**0**

Crossrail 2 is a proposed railway linking the national rail networks in Surrey and Hertfordshire via an underground tunnel through London.

*This data is sourced from publicly available information by Groundsure.*

## 22.10 HS2

**Records within 500m**

**0**

HS2 is a proposed high speed rail network running from London to Manchester and Leeds via Birmingham. Main civils construction on Phase 1 (London to Birmingham) of the project began in 2019, and it is currently anticipated that this phase will be fully operational by 2026. Construction on Phase 2a (Birmingham to Crewe) is anticipated to commence in 2021, with the service fully operational by 2027. Construction on Phase 2b (Crewe to Manchester and Birmingham to Leeds) is scheduled to begin in 2023 and be operational by 2033.

*This data is sourced from HS2 Ltd.*



## Data providers

Groundsure works with respected data providers to bring you the most relevant and accurate information. To find out who they are and their areas of expertise see <https://www.groundsure.com/sources-reference> ↗.

## Terms and conditions

Groundsure's Terms and Conditions can be accessed at this link: [www.groundsure.com/terms-and-conditions-april-2023/](http://www.groundsure.com/terms-and-conditions-april-2023/) ↗.



## **B. British Geological Society Historic Borehole Records**



**BOREHOLE LOG**

BOREHOLE No 90.

GROUND LEVEL : 36.83

TYPE OF BORING: Shell and Auger.

DATE STARTED : 18.6.62.

DIA OF BORING: 8"

DESCRIPTION	THICKNESS	DEPTH	LEGEND	SAMPLE No	No of BLOWS OR LOAD.	LABORATORY TESTS.	Tools Used.
TOPSOIL.	1' 3"	0' 0"					Shell and Auger.
Firm sandy CLAY with compact f.m.c. gravel.	1' 6"	1' 3"		• 1			
Medium density fine brown-black organic silty SAND.	4' 3"	2' 9"		+ 2	25 blows/ft	S	
Medium density brown SAND with f.m.c. gravel and thin layers of silt.	3' 6"	7' 0"		• 3			
Medium density f.m.c. SAND and Gravel with bands of silty sand and silt.	11' 0"	10' 6"		+ 4	21 blows/ft		
				• 5			
				+ 6	25 blows/ft	S	
Medium density brown and black f.m.c. sandy GRAVEL.	1' 9"	21' 6"		+ 8	20 blows/ft		
		23' 3"		• 9	100 blows/ft		
Very stiff red, white and grey marly CLAY with pieces of marl.	4' 9"	28' 0"		• 10			
Hard red, white and grey MARL.	2' 0"	30' 0"		• 11			

REMARKS:

**KEY TO LABORATORY TESTS**  
W = MOISTURE CONTENT; S = SIEVE ANALYSIS; H = FULL MECH-ANICAL ANALYSIS; A = PLASTICITY INDEX; P = DRY DENSITY/MOISTURE RELATION; T<sub>d</sub> = DRAINED TRIAXIAL; T<sub>u</sub> = UNDRAIN-ED TRIAXIAL; R<sub>d</sub> = REMOULDED DRAIN-ED TRIAXIAL; R<sub>u</sub> = REMOULDED UN- DRAIN-ED TRIAXIAL; K = C.B.R. (UNSOAKED); K<sub>s</sub> = C.B.R. (SOAKED); C = CONSOLIDATION; U = UNCONFINED COMPRESSION TEST; B = SHEAR BOX

LONDON-SOUTH WALES MOTORWAY  
COLDRA - CRICK.

**KEY TO SAMPLES.**  
 UNDISTURBED SAMPLE  
 DISTURBED SAMPLE  
 S.P.T. No. OF BLOWS  
 WATER LEVEL

FOUNDATION ENGINEERING LIMITED;  
111, WESTMINSTER BRIDGE ROAD,  
LONDON S.E. 1.



**BOREHOLE LOG**

BOREHOLE No 91

GROUND LEVEL : 34.5

TYPE OF BORING: Shell and Auger.

DATE STARTED : 16.6.62

DIA OF BORING: 8"

DESCRIPTION	THICKNESS	DEPTH	LEGEND	SAMPLE No	No of BLOWS OR LOAD.	LABORATORY TESTS.	TOOLS Used.
TOPSOIL.	1'0"	0'0"					
Soft brown very sandy CLAY and f.m.c. gravel.	1'0"	1'0"					Shell and Auger.
Medium density coarse brown clayey SAND and f.m.c. gravel.	2'0"	2'0"	• 1				
Medium density fine brown and black organic silty SAND.	5'6"	4'0"	• 2 X W X + 3		20 blows/ft	S	
Medium density f.m.c. sandy GRAVEL.	2'0"	9'6"	• 4		32 blows/ft		
	+	11'6"					

REMARKS:

<b>KEY TO LABORATORY TESTS</b>		LONDON- SOUTH WALES MOTORWAY COLDRA - CRICK.
W = MOISTURE CONTENT; S = SIEVE ANALYSIS; H = FULL MECH-ANICAL ANALYSIS; A = PLASTICITY INDEX; P = DRY DENSITY/MOISTURE RELATION; Td = DRAINED TRIAXIAL; Tu = UNDRAINED TRIAXIAL; Rd = REMOULDED DRAINED TRIAXIAL; Ru = REMOULDED UNDRAINED TRIAXIAL; K = C.B.R. (UNSOAKED); Ks = C.B.R. (SOAKED); C = CONSOLIDATION; U = UNCONFINED COMPRESSION TEST; B = SHEAR BOX		
KEY TO SAMPLES.	UNDISTURBED SAMPLE • DISTURBED SAMPLE	FOUNDATION ENGINEERING LIMITED; 111, WESTMINSTER BRIDGE ROAD, LONDON, S.E.1.
CORE BORING % RECOVERY	+ S.P.T. No of BLOWS ≡ WATER	

**BOREHOLE LOG**

BOREHOLE No 92.

GROUND LEVEL : 24.2.

TYPE OF BORING: Shell and Auger.

DATE STARTED : 14.6.62.

DIA OF BORING: 6"

DESCRIPTION	THICKNESS	DEPTH	LEGEND	SAMPLE No	No of BLOWS OR LOAD	LABORATORY TESTS	TOOLS USED
Soft brown silty CLAY.	5' 6"	0' 0"	X				Shell and Auger.
		X	.1				
Stiff red marly CLAY with medium large gravel.	6' 0"	5' 6"	X	.2	26 blows/ft.	Tu	
		X	.3				
		X					
Stiff red-brown MARL and friable silty Clay.	3' 6"	11' 6"	X	.4	56 blows/ft.		
		X	.5				
Hard red-brown MARL and friable silty clay.	9' 0"	15' 0"	X	.6	61 blows/ft.		
		X	.7				
		X	.8a.				
SANDSTONE.	1' 0"	24' 0"	X	.8b.	115 blows/ft.		
		X	.9				
		X	.10				
		25' 0"	X	.11			

REMARKS:

<p><b>KEY TO LABORATORY TESTS</b></p> <p>W = MOISTURE CONTENT; S = SIEVE ANALYSIS; H = FULL MECH-ANICAL ANALYSIS; A = PLASTICITY INDEX; P = DRY DENSITY/MOISTURE RELATION; Td = DRAINED TRIAXIAL; Tu = UNDRAINED TRIAXIAL; Rd = REMOULDED DRAINED TRIAXIAL; Ru = REMOULDED UNDRAINED TRIAXIAL; K = C.B.R. (UNSOAKED); Ks = C.B.R. (SOAKED); C = CONSOLIDATION; U = UNCONFINED COMPRESSION TEST; B = SHEAR BOX</p>		<p>LONDON - SOUTH WALES MOTORWAY COLDRA - CRICK.</p>
---	--	--

<p>KEY TO SAMPLES</p> <p>□ CORE BORING % RECOVERY</p>	<p>▬ UNDISTURBED SAMPLE</p> <p>+ S.P.T. No. OF BLOWS</p>	<p>● DISTURBED SAMPLE</p> <p>≡ WATER LEVEL</p>	<p>FOUNDATION ENGINEERING LIMITED; 111, WESTMINSTER BRIDGE ROAD, LONDON S.E.1.</p>
---	--	--	--



**BOREHOLE LOG**

BOREHOLE N° 72A.

GROUND LEVEL : 24.00

TYPE OF BORING: Shell and Auger

DATE STARTED : 18.10.62.

DIA OF BORING: 6"

DESCRIPTION	THICKNESS	DEPTH	LEGEND	SAMPLE N°	N° OF BLOWS OR LOAD	LABORATORY TESTS	TOOLS USED
TOPSOIL. (Hard red clay).	2' 6"	0' 0"					
Grey silty CLAY with traces of sand.	1' 6"	2' 6"	X	• 1			
		4' 0"	X	• 2			
Grey silty CLAY.	3' 6"	7' 6"	X	• 3			
	+		X	• 4	21 blows/ft.	TU	

REMARKS:

**KEY TO LABORATORY TESTS**

W = MOISTURE CONTENT ; S = SIEVE ANALYSIS ; H = FULL MECH - ANICAL ANALYSIS ; A = PLASTICITY INDEX ; P = DRY DENSITY / MOISTURE RELATION ; T<sub>D</sub> = DRAINED TRIAXIAL ; T<sub>U</sub> = UNDRAINED TRIAXIAL ; R<sub>d</sub> = REMOULDED DRAINED TRIAXIAL ; R<sub>u</sub> = REMOULDED UNDRAINED TRIAXIAL ; K = C.B.R. (UNSOAKED) ; K<sub>s</sub> = C.B.R. (SOAKED) ; C = CONSOLIDATION ; U = UNCONFINED COMPRESSION TEST ; B = SHEAR BOX

LONDON - SOUTH WALES MOTORWAY  
COLDRA - CRICK.

KEY TO SAMPLES.	UNDISTURBED SAMPLE	DISTURBED SAMPLE	FOUNDATION ENGINEERING LIMITED ; 111, WESTMINSTER BRIDGE ROAD, LONDON, S. E. 1.
CORE BORING % RECOVERY	S.P.T. N° OF BLOWS	WATER	

**BOREHOLE LOG**

BOREHOLE No 93

GROUND LEVEL : 36.89

TYPE OF BORING: Shell and Auger.

DATE STARTED : 22.6.62.

DIA OF BORING: 8"

DESCRIPTION	THICKNESS	DEPTH	LEGEND	SAMPLE No	No of BLOWS OR LOAD.	LABORATORY TESTS.	TOOLS USED.
Medium density brown SAND with c.m.f. gravel and occasional sandstone.	15' 0"	0' 0"		• 1	19 blows/ft.	S	Shell and Auger.
		+ 2					
		• 3					
		+ 4					
		• 5					
		+ 6					
Medium density brown SAND with c.m.f. gravel and traces of clay.	0' 9"	15' 0"		+ 6	29 blows/ft.		
		15' 9"					
Stiff red-brown and grey silty CLAY.	14' 3"	+		• 7	48 blows/ft.		
				• 8			
				• 9			
				• 10			
				• 11			
				• 12			
				• 13			
	30' 0"				150 blows/ft.		

REMARKS: U+ attempted at 29' 0". 250 blows/ft. No recovery.

KEY TO LABORATORY TESTS			LONDON - SOUTH WALES MOTORWAY COLDRA - CRICK.
<p>W = MOISTURE CONTENT; S = SIEVE ANALYSIS; H = FULL MECH - ANICAL ANALYSIS; A = PLASTICITY INDEX; P = DRY DENSITY/MOISTURE RELATION; T<sub>D</sub> = DRAINED TRIAXIAL; T<sub>U</sub> = UNDRAINED TRIAXIAL; R<sub>D</sub> = REMOULDED DRAINED TRIAXIAL; R<sub>U</sub> = REMOULDED UNDRAINED TRIAXIAL; K = C.B.R. (UNSOAKED); K<sub>s</sub> = C.B.R. (SOAKED); C = CONSOLIDATION; U = UNCONFINED COMPRESSION TEST; B = SHEAR BOX</p>			
KEY TO SAMPLES.	UNDISTURBED SAMPLE	DISTURBED SAMPLE	FOUNDATION ENGINEERING LIMITED; 111, WESTMINSTER BRIDGE ROAD, LONDON S.E.1.
□ CORE BORING % RECOVERY	+ S.P.T. No of BLOWS	▬ WATER LEVEL	



**BOREHOLE LOG**

BOREHOLE No 95.

GROUND LEVEL : 46.00

TYPE of BORING: Shell and Auger.

DATE STARTED : 27.6.62

DIA of BORING: 8"

DESCRIPTION	THICKNESS	DEPTH	LEGEND	SAMPLE No	No of BLOWS OR LOAD.	LABORATORY TESTS.	TOOLS USED.
TOPSOIL.	1'0"	0'0"					
Firm brown sandy CLAY with m.c. gravel.	4'0"	1'0"		• 1			Shell and Auger.
Medium density m.f. brown SAND.	2'6"	5'0"		+ 2	25 blows/ft		
Medium density m.f. brown clayey SAND with sandstone pieces	5'0"	7'6"		• 3			
		12'6"		+ 4	32 blows/ft		
				• 5			
Medium density cm.f. GRAVEL with pieces of clayey sand.	8'0"			+ 6	20 blows/ft		
				• 7			
		20'6"		+ 8	95 blows/ft		

REMARKS:

<p><b>KEY TO LABORATORY TESTS</b></p> <p>W = MOISTURE CONTENT; S = SIEVE ANALYSIS; H = FULL MECH-ANICAL ANALYSIS; A = PLASTICITY INDEX; P = DRY DENSITY/MOISTURE RELATION; T<sub>d</sub> = DRAINED TRIAXIAL; T<sub>u</sub> = UNDRAIN-ED TRIAXIAL; R<sub>d</sub> = REMOULDED DRAIN-ED TRIAXIAL; R<sub>u</sub> = REMOULDED UN- DRAIN-ED TRIAXIAL; K = C.B.R. (UNSOAKED); K<sub>s</sub> = C.B.R. (SOAKED); C = CONSOLIDATION; U = UNCONFINED COMPRESSION TEST; B = SHEAR BOX.</p>		<p>LONDON - SOUTH WALES MOTORWAY COLDRA - CRICK.</p>
<p>KEY TO SAMPLES.</p> <p>▬ UNDISTURBED SAMPLE</p> <p>● DISTURBED SAMPLE</p>	<p>+ S.P.T. No of BLOWS</p> <p>≡ WATER LEVEL</p>	<p>FOUNDATION ENGINEERING LIMITED; 111, WESTMINSTER BRIDGE ROAD, LONDON S.E.1.</p>



INSTITUTE OF GEOLOGICAL SCIENCES  
**RECORD OF SHAFT OR BOREHOLE**

6-in Map Registration No.

ST 49 SE/8

Name and Number of Shaft or Borehole:

No 12 Severn Bridge Approach M37

National Grid Reference

4913 9033

For whom made

Amey's Aggregates

Town or Village

County Glas

Exact site (reference to a fixed point on 1-in map):

1-in New Series Map No.

250

Enter 'C' if Confidential

Purpose for which made

Gravel

Ground Level at <sup>shaft</sup> <sub>bore</sub> relative to O.D. If not ground level give O.D. of beginning of <sup>shaft</sup> <sub>bore</sub>

Made by

Date of sinking

Information from

Examined by

**RECORD OF BOREHOLE M36**

ST/49 SE 8

8 in. to 23ft. 6 in.

Ground level : + 78.6ft. O.D. Newlyn Dia. of boring : 8X (18 in. core) to 30ft.

Type of boring : Shell and Auger Rotary Core Drilling Lining tubes : 8 in. to 5ft. 6 in.

Depth (ft.)	Angle	Sample	Notes	Depth (ft.)	Notes
23.2.60.	2° 6"	D	(1:80)	1' 0"	+77.6 TOPSOIL
24.2.60.					
25.2.60.	12° 0"	BD			Firm to stiff red-brown silty CLAY with rock fragments and boulders (limestone)
26.2.60.					
27.2.60.	19° 6"	W			
29.2.60.	24° 0"			23' 6"	+55.1
				(7 1/2)	
18.3.60.	30° 0"	100%		30' 0"	+48.6
				(9 1/2)	
					Fractured grey LIMESTONE (carboniferous limestone)

Key to type of sample :

- U (4) — 4 in. dia. undisturbed sample.
- U (1 1/2) — 1 1/2 in. dia. " "
- D — disturbed sample.
- BD — bulk disturbed sample.
- W — water sample.
- S ( ) — standard penetration test.
- C ( ) — dynamic cone penetration test.
- No. in brackets gives No. of blows/12 in. penetration.

Remarks : (Observations on ground-water, etc.)

- B.H.M35 No ground water was encountered during boring
- B.H.M36 Owing to the qualities of water added for shelling, no record could be obtained of ground water levels.

SEVERN BRIDGE APPROACHES

Soils No:

S/2288

**FIG. 24**

GEORGE WIMPEY & CO., LTD.

CENTRAL LABORATORY

HAYES

D 7547 Wt. 2





RECORD OF BOREHOLE M37

ST/49 SE 9

Ground level : +59.7ft. O.D. Newlyn

Dia. of boring : 12in. to 12ft.6in.  
BX (1 1/8in. core) to 20ft.

Type of boring : Powered Auger and Rotary Core Drilling

Lining tubes : BX to 12ft.6in.

Daily Progress	Core Recovery and Samples		Change of Strata			Description of Strata
	Depth	Percentage and Type	Legend	Depth	O.D. Level	
	3'6" - 5'0"	U (4) D		(1 3/8") 6'0"	+53.7	Stiff red-brown silty CLAY
	7'6"	D		(2 2/4") 7'6"	+52.2	Medium brown clayey SAND
	8'0" - 9'6"	U (4) D				Red-brown silty CLAY with bands of conglomeratic limestone. (Dolomitic Conglomerate)
23.2.60.	11'0"	D				
27.2.60.	12'0"	D				
	14'6"					
21.3.60	20'0"	85%		20'0"	+39.7	
				(1 1/8")		

Key to type of sample :  
 U (4) — 4 in. dia. undisturbed sample.  
 U (1 1/2) — 1 1/2 in. dia. " "  
 D — disturbed sample.  
 BD — bulk disturbed sample.  
 W — water sample.  
 S ( ) — standard penetration test.  
 C ( ) — dynamic cone penetration test.  
 No. in brackets gives  
 No. of blows/12 in. penetration.

Remarks : (Observations on ground-water, etc.)

SEVERN BRIDGE APPROACHES

Soils No :  
S/2288

FIG. 25

BOREHOLE LOG

BOREHOLE No 96

GROUND LEVEL : 51.3

TYPE OF BORING: Shell and Auger.

DATE STARTED : 29.6.62

DIA OF BORING: 8"

DESCRIPTION	THICKNESS	DEPTH	LEGEND	SAMPLE No	No of BLOWS OR LOAD.	LABORATORY TESTS.	TOOLS USED.
TOPSOIL.	1'6"	0'0"					Shell and Auger.
Firm brown sandy CLAY with fragments of sandstone.	6'6"	1'6"		• 1	60 blows/ft.	Tu	
				• 2			
				• 3			
				• 4			
Medium density fine brown SAND.	12'0"	8'0"		+ 5	11 blows/ft.		
				+ 6	10 blows/ft.		
				• 7			
Medium density m.f. brown SAND and Gravel.	0'6"	20'0"		+ 8	13 blows/ft.		
		20'6"					

REMARKS:

**KEY TO LABORATORY TESTS**  
 W = MOISTURE CONTENT; S = SIEVE ANALYSIS; H = FULL MECH-ANICAL ANALYSIS; A = PLASTICITY INDEX; P = DRY DENSITY/MOISTURE RELATION; Td = DRAINED TRIAXIAL; Tu = UNDRAINED TRIAXIAL; Rd = REMOULDED DRAINED TRIAXIAL; Ru = REMOULDED UNDRAINED TRIAXIAL; K = C.B.R. (UNSOAKED); Ks = C.B.R. (SOAKED); C = CONSOLIDATION; U = UNCONFINED COMPRESSION TEST; B = SHEAR BOX.

LONDON - SOUTH WALES MOTORWAY  
COLDRA - CRICK.

**KEY TO SAMPLES.**  
 ▬ UNDISTURBED SAMPLE  
 • DISTURBED SAMPLE  
 + S.P.T. No of BLOWS  
 ▽ WATER

FOUNDATION ENGINEERING LIMITED;  
111, WESTMINSTER BRIDGE ROAD,  
LONDON, S.E.1.

## C. Site Walkover Survey Photographs

**Photo C.1: View across the site looking to the north.**



**Photo C.2: View across the site looking to the north-east**



**Photo C.3: View of the northern end of the site, looking north; Crick road to the west, M48 carried on bridge over Crick Road**



**Photo C.4: Eastern boundary looking north**



**Photo C.5: Centre of the site looking south**



**Photo C.6: Southern end of the site looking south-west.**



**Photo C.7: Centre of the site looking south-west.**



**Photo C.8: South-east of the site looking east.**



**Photo C.9: Animal water trough adjacent to the site's south-western entrance**



**Photo C.10: Water utility manhole in the sites north-western corner.**







This page is intentionally left blank

Langley Close  
**Magor**  
**Monmouthshire**

A **Preliminary Ecological**  
**Appraisal By:**



  
Ecological Consultancy

On **Behalf Of:**



February **2024**

File Reference: **JM18823**

Status	Name	Position	Date
Author	Phoebe Williams BA (Hons) MSc	Ecologist	1 <sup>st</sup> February 2024
Reviewer	Carola Hoskins BA (Hons) MSc ACIEEM	Principal Ecologist	6 <sup>th</sup> February 2024
Valid until	12 <sup>th</sup> January 2026		

**Directors:** Carola Hoskins BA (Hons) MSc ACIEEM Robert Morgan Phoebe Williams BA (Hons) MSc  
**Registered Office:** Suite 131 -136, Plas y Ffynnon, Cambrian Way, Brecon LD3 7TG  
**Web Site:** [www.justmammals.co.uk](http://www.justmammals.co.uk) **Email:** [phoebe@justmammals.co.uk](mailto:phoebe@justmammals.co.uk) **Telephone:** 01874 623616  
**Registered In:** Wales **Registration Number:** 13099914 **VAT No:** 821 6376 35

## Contents

	<b>Page No.</b>	
<b>1</b>	<b>Executive Summary</b>	<b>1</b>
<b>2</b>	<b>Introduction</b>	<b>1</b>
<b>3</b>	<b>Survey Team Experience</b>	<b>1 – 2</b>
<b>4</b>	<b>Survey Methodology</b>	<b>2</b>
<b>5</b>	<b>Site Description</b>	<b>2</b>
<b>6</b>	<b>Desktop Study</b>	<b>2 – 3</b>
<b>7</b>	<b>Survey Constraints</b>	<b>3</b>
<b>8</b>	<b>Survey Results</b>	<b>3 – 5</b>
<b>9</b>	<b>Discussion and Conclusions</b>	<b>5</b>
<b>10</b>	<b>Recommendations</b>	<b>5 – 6</b>
<b>10</b>	<b>Bibliography</b>	<b>7</b>
	<b>Appendix I: Site Location Plan</b>	<b>8</b>
	<b>Appendix II: Site Photographs</b>	<b>9</b>
	<b>Appendix III: Phase 1 Habitat Map</b>	<b>10</b>
	<b>Appendix IV: Relevant Legislation</b>	<b>11</b>

### List of Tables

Table	Description of Contents	Page No.
Table 1	Summary of Survey Activity and Weather Conditions	3
Table 2	Summary of Phase 1 Habitat Notes	4
Table 3	Recommended Native Tree and Shrub Species	6

### List of Figures

Figure	Description of Contents	Page No.
Figure 1	Site location plan	8
Figure 2	Phase 1 habitat survey map	10

### List of Plates

Plate	Description of Contents	Page No.
Plate 1	Looking east across the site	9
Plate 2	Looking west across the site	9
Plate 3	Target note 1: mature oak with PRF and cavity	9
Plate 4	Looking north along eastern hedgerow boundary	9
Plate 5	Target note 2: mature oak with PRF	9
Plate 6	Looking south at the eastern end of the site	9
Plate 7	South-west boundary	9
Plate 8	Looking west across the site	9

## 1 Executive Summary

- 1.1 A suitability assessment of various sites in Monmouthshire is being carried out by Monmouthshire County Council for the possible creation of Gypsy Roma Traveller Sites, to be included within the Replacement Local Development Plan. An area of land to the rear of Langley Close, in Magor, forms part of the suitability assessment. To support the proposals, a Preliminary Ecological Appraisal of the land was conducted in January 2024, by an ecologist and an assistant.
- 1.2 The land subject to survey covers around 2.9ha, and comprises three agricultural fields. Boundary features include treelines, woodland, hedgerows and fencing. The land is currently used to keep livestock, resulting in heavily grazed grassland, and areas of bare ground due poaching. Electric wire fencing is used across the site for stock proofing. The surrounding landscape includes adjacent agricultural fields to the west, and residential housing to the south. The M4 stretches immediately north of the site.
- 1.3 Protected species and their potential presence on site were considered as part of the assessment. If no impacts to the woodland, trees or hedgerow on site are anticipated, then no further survey is required at the site at this time. It is recommended that these features on site are retained and safeguarded as part of the proposals, as this will help in retaining ecological value on site. If impacts to the features cannot be avoided, then further survey will be required, by way of assessment to determine suitability of trees for roosting bats and likely absence/presence of dormice within the northern woodland and connecting hedgerow. If only a small section of hedgerow is proposed to be removed, for access requirements, then it is possible that works could be carried out under a method statement to account for the potential presence of hazel dormouse. Recommendations are provided in this report.
- 1.4 Breeding birds are likely to be present on site, due to the suitability of habitat. Although the majority of onsite hedgerows, woodland and tree lines are to be retained, removal of a section of hedgerow may be required for access. Any removal of vegetation must be timed to occur outside the breeding season for birds.
- 1.5 Enhancements for biodiversity are required to meet the planning policy as indicated by Planning Policy Wales 11, and Future Wales, policy documents. This report makes recommendations to provide enhancements for biodiversity on site, including the installation of bird and bat boxes, as well as re-instatement planting of hedgerows and enhancement planting of woodland.

## 2 Introduction

- 2.1 Just Mammals Limited was commissioned by Monmouthshire County Council (MCC) to complete a Preliminary Ecological Appraisal of an area of land to the rear of Langley Close, Magor. The site subject to survey comprises three agricultural fields, centred on National Grid Reference ST 42201 87734, standing at an altitude of 21m Above Ordnance Datum.
- 2.2 MCC are currently considering the suitability of various sites in Monmouthshire for the creation of Gypsy Roma Traveller (GRT) Sites, to be included within the Replacement Local Development Plan (RLDP). Due to the early stages of the assessment, no design plans are available at the time of writing this report. To support the plans, Just Mammals Limited were commissioned to carry out a Preliminary Ecological Appraisal of the land at Langley Close, Magor. This assessment was undertaken on the 12<sup>th</sup> of January 2024.
- 2.3 This report makes recommendations concerning the ecological value of the site, as well as the need for further survey work as appropriate. The different types of habitat were assessed, and the potential presence of protected species, such as badger (*Meles meles*), otter (*Lutra lutra*), dormouse (*Muscardinus avellanarius*), reptiles and amphibians, as well as bats and nesting birds were considered. Section 7 species such as hedgehog (*Erinaceus europaeus*) were also considered.

## 3 Survey Team Experience

- 3.1 Undertaking the assessment, and author of this report is Phoebe Williams. A Geography graduate from the University of Exeter, and a former trainee at Gwent Wildlife Trust she has completed a Natural Talent trainee programme, studying Hemiptera at the National Museum of Wales. Practical experience includes survey work for dormice, botany, newts, reptiles, and invertebrates. Phoebe has undertaken an MSc in Wildlife and Conservation Management at the University of South Wales.

She is an ecologist with Just Mammals Limited. Phoebe holds a Great crested newt (NRW) S092295/1 (Expiry 26th February 2025), and is an accredited agent on NRW bat licence S091842/2 (expiry 10<sup>th</sup> November 2024).

- 3.2 Assisting with the survey effort was Catherine Povey. After graduating from Swansea University and UCL Catherine worked in medical research and as a practitioner. Since the first year of her degree when she studied Zoology and Botany, she has retained a keen interest in the natural world and has worked with Bannau Brycheiniog National Park on a number of projects including peat conservation. She is employed by Just Mammals Limited as a Trainee Ecologist and has conducted a variety of surveys with the company, including dusk bat emergence surveys for commercial projects.

## 4 Survey Methodology

- 4.1 A Preliminary Ecological Appraisal (PEA) was conducted on the 12<sup>th</sup> of January 2024. Details of the survey and weather conditions are provided in Table 1. Prior to the site visit, a desktop study was undertaken, which involved a standard search area of a 2km radius from the site (using a central grid reference), using the MAGIC website. Details of statutory sites designated for nature conservation were obtained. A record search was also commissioned from South East Wales Biodiversity Records Centre (SEWBRc).
- 4.2 The assessment comprised a survey employing the Phase 1 habitat survey methodology. This is a standardised technique for classifying and mapping British habitats. All areas within the site were inspected and assessed for indicators of ecological value, including the presence and/or field signs of any protected or rare habitats and species. The site was walked over, recording all plant species and features onto a custom-made recording sheet. Habitats and notes were drawn onto a map of the survey site and photographs were taken. A coloured Phase 1 habitat map was produced (Appendix III).
- 4.3 Assessment for the presence or potential absence of other protected species, including hazel dormouse, badger, reptiles and amphibians, was undertaken by considering the features of the site. Such features include grassland and dense vegetation. The potential suitability of the site for nesting birds was also considered.

## 5 Site Description

- 5.1 Situated at the north-west edge of Magor, approximately 5km south-west of Caldicot, the site subject to survey covers around 2.9ha, and comprises three agricultural fields. Boundary features include treelines, woodland, hedgerow and fencing. Fields are divided up by hedgerows and fencing. The land is currently used by its tenants to house cattle and horses, resulting in heavily grazed grassland, and areas of bare ground, due to high levels of disturbance. The horses are kept within the eastern end of the site, while cattle roam to the west. Electric wire fencing is used across the site for stock proofing.
- 5.2 The surrounding landscape includes adjacent fields to the west, and residential housing to the south. To the east of the site runs St Brides Road, beyond which stretch grassland fields that make up part of Grange Road Site of Importance for Nature Conservation. The M4 motorway stretches immediately north of the site, east to west.

## 6 Desktop Study

- 6.1 A record search was commissioned from South East Wales Biological Records Centre (SEWBRc) (unique reference 0234-698) to ascertain whether protected species have been recorded at or close to the site. The search revealed no records of priority species at the site.
- 6.2 The data set revealed protected species records within 1km of the site. The record search is summarised below:
- The closest mammal record to the site is of an unidentified bat over 90m from the site, other bat species recorded in the area include noctule (*Nyctalus noctula*) over 450m from the site, and lesser noctule (*Nyctalus leisleri*) 800m away. Stoat (*Mustela erminea*), and hedgehog (*Erinaceus europaeus*), have been recorded around 300m from the site, water vole (*Arvicola amphibius*) and otter (*Lutra lutra*) over 450m from the site, badger (*Meles meles*) over 900m from the site, and dormouse (*Muscardinus avellanarius*) over 1.4km from the site;

- Bird records include swift (*Apus apus*) around 100m from the site, willow warbler (*Phylloscopus trochilus*) 170m from the site, over 300m away swallow (*Hirundo rustica*), long-tailed tit (*Aegithalos caedatus*), whitethroat (*Curruca communis*), snipe (*Gallinago gallinago*), and wheatear (*Oenanthe oenanthe*) have been recorded, short-eared owl (*Asio flammeus*) has been recorded around 400m away, and over 500m from the site bird records include kingfisher (*Alcedo atthis*), red kite (*Milvus milvus*), teal (*Anas crecca*), redstart (*Phoenicurus phoenicurus*), and barn owl (*Tyto alba*);
  - A single reptile record was returned within 1km of the site (around 700m away) of grass snake (*Natrix helvetica*), adder (*Vipera berus*) has been recorded over 1km from the site, amphibian records include common frog (*Rana temporaria*), common toad (*Bufo bufo*) and smooth newt (*Lissotriton vulgaris*) all over 1km from the site;
  - Invertebrate (other marine or freshwater) records include three mollusc records over 600m from the site, and a single crustacean record over 1.2km from the site;
  - Invertebrate (insect) records include several moths such as goat moth (*Cossus cossus*), and Bulrush Veneer (*Calamotropha paludella*) over 500m from the site;
  - Vascular plants include bee orchid (*Ophrys apifera*), sea pealwort (*Sagina maritima*), henbit dead-nettle (*Lamium amplexicaule*), early meadow grass (*Poa infirma*), and yellow-wort (*Blackstonia perfoliata*), bluebell (*Hyacinthoides non-scripta*) recorded between 250 – 500m from the site;
  - Bryophytes include records of common pocket-moss (*Fissidens taxifolius*) and wall screw-moss (*Tortula muralis*) over 800m from the site.
- 6.3 By consulting Magic Map, it was determined that no part of the site contains, or is within, any statutory sites of nature conservation interest, such as a Site of Special Scientific Interest (SSSI), Special Areas of Concern (SAC), National Nature Reserve (NNR) or Local Nature Reserves (LNR) etc. No sites of conservation interest form part of the site. The desktop study confirmed four sites of interest within 2km of the site. These include Penhow Woodlands NNR and SSSI 1.7km to the north of the site, Magor Marsh SSS 1km to the south-east of the site, Gwent Levels – Redwick and Llandevenny SSSI 970m to the south-west of the site, and Gwent Levels – Magor and Undy SSSI 1.9km to the south-east of the site.
- 6.4 The record search also revealed Sites of Importance for Nature Conservation (SINC) within 1km of the area of land subject to survey. These are listed below with significance of the sites also included, where information is available:
- Grange Wood & The Larches: just over 960m from the site;
  - Grange Road: 100m to the east of the site, species rich neutral grassland;
  - Bluehouse Farm: 860m from the site, species rich grassland with a mosaic of damp and dry habitats;
  - Upper Grange Farm Field: 460m from the site, species rich calcareous grassland.
- 6.5 The site subject to survey does not form part of any of the above designated sites. Grange Road SINC is located within close proximity to the site, just east, designated for species rich neutral grassland. Impacts to this SINC as a result of the proposed development site, such as run-off will need to be considered as part of the suitability assessment. Given the scale of the development, the distance of all other sites of conservation interest from the site subject to assessment, and significance of the sites, it is considered unlikely that proposals will impact any of these designated sites within the surrounding area at this time.

## 7 Survey Constraints

- 7.1 The comprehensiveness of any ecological assessment may be limited by the nature of the site visit, it being a single snapshot of the site at any point in time. This report cannot therefore be considered to provide a fully comprehensive analysis of the ecological interest of the site. However, it does provide an ecological assessment of the site for supporting habitats and species on the day of the visit and highlights areas where further survey work may be required.

## 8 Survey Results

- 8.1 Details of the conditions under which survey was conducted is given in Table 1. Wind speeds given employ the Beaufort scale.

**Table 1: Summary of Survey Activity and Weather Conditions**

Survey Type and Location	Dates	Timing	Weather Conditions
--------------------------	-------	--------	--------------------



Day time visual inspection, botanical survey and habitat assessment, including protected species assessment	12/01/2024	10.00 – 12.00 hours Greenwich Mean Time	Air temperature: 5°C Cloud cover: 8/8 oktas Wind speed: F2, light breeze Conditions: Dry
<b>Surveyors</b>	Phoebe Williams and Catherine Povey		

- 8.2 The site was divided into eight different types of habitat for recording purposes. A coloured Phase 1 habitat map was produced (see Appendix III). Table 2 below provides details of the various habitats and the dominant species for each of them.

**Table 2: Summary of Phase 1 Habitat Notes**

Habitat	Phase 1 Classification	Description of Area and Typical Species
Type 1	B6 Poor semi-improved grassland	Just under half of the site comprises this habitat type. Grassland sward is short, with evidence of disturbance shown by patchy areas.  Species present include perennial rye grass ( <i>Lolium perenne</i> ), annual meadow grass ( <i>Poa annua</i> ), broad-leaved dock ( <i>Rumex obtusifolius</i> ), creeping buttercup ( <i>Ranunculus repens</i> ), Yorkshire fog ( <i>Holcus lanatus</i> ), ragwort ( <i>Jacobaea vulgaris</i> ), and common sorrel ( <i>Rumex acetosa</i> ).
Type 2	J4 Bare ground	This habitat makes up a large portion of the site as a result of high levels of disturbance by cattle, horses, and farm vehicles.  Few species grow, including creeping buttercup and meadow buttercup ( <i>Ranunculus acris</i> ).
Type 3	A3.1 Scattered trees	A small number of trees stand at the bottom of the adjacent residential gardens to the south of the site. These are at the boundary edge. Specimens are mature.  Species present include pedunculate oak ( <i>Quercus robur</i> ) and sycamore ( <i>Acer pseudoplatanus</i> ).
Type 4	J2.1.2 Intact hedgerow, species poor	This habitat is present at the southern and north-west corner of the site. There are fewer than five woody species along a typical 30m stretch.  Species present include beech ( <i>Fagus sylvatica</i> ), ivy ( <i>Hedera helix</i> ), hawthorn ( <i>Crataegus monogyna</i> ), and holly ( <i>Ilex aquifolium</i> ).
Type 5	J2.2.2 Defunct hedgerow, species poor	Defunct hedgerow aligns field boundaries at the centre of the site. The hedgerow features trees with exposed roots that have been disturbed by cattle. Species include hawthorn and elm ( <i>Ulmus sp.</i> ).
Type 6	J2.3.2 Hedge with trees, species poor	At the eastern and western ends of the site, trees align the hedgerow. Specimens are mature.  Species include hawthorn, ivy, lesser celandine ( <i>Ficaria verna</i> ), sycamore, walnut ( <i>Juglans regia</i> ), and bramble ( <i>Rubus fruticosus</i> ).  <b>Target Note 1: Walnut tree with Potential Roost Feature</b>
Type 7	J2.4 Fence	A post and wire fence aligns most of the site boundaries, a timber fence is present at the south-east end of the site.
Type 8	A1.1.1 Broadleaved woodland, semi natural	To the north of the site a band of woodland is present.  Species present include lords and ladies ( <i>Arum maculatum</i> ), pedunculate oak, hazel, holly, elder ( <i>Sambucus nigra</i> ), dogwood ( <i>Cornus sanguinea</i> ) and hard fern ( <i>Blechnum spicant</i> ). Ivy and bramble cover the woodland floor.

- 8.3 Ecological assessment included identification of the potential for protected species to be present on site. Reptiles make use of open, rank habitats which provide a mixture of open areas and cover. Habitat on site comprises short sward, disturbed grassland that is grazed by cattle and horses.
- 8.4 During the terrestrial part of their lifecycle, amphibians have similar habitat requirements to reptiles, with both species' groups favouring unmanaged, rank grassland, scrubby vegetation and variation in vegetative architecture. No amphibians were noted during the survey. No ponds are present, ruling out the possibility for them to breed on site. Since great crested newts are known to use terrestrial habitat up to 500m from their breeding ponds, the wider landscape must also be taken into consideration. Review of aerial maps show no ponds within 500m of the site.
- 8.5 Bats use trees as well as buildings for roosting, where they will exploit gaps, cracks and crevices in the bark. An extensive survey of trees and their suitability for bats was not undertaken, as this is beyond the scope of the preliminary assessment. However, a walnut tree (Target Note 1) was noted as having a Potential Roost Feature. This feature was not inspected during the PEA.

- 8.6 The vegetated site boundaries and woodland on site are likely to attract a variety of invertebrate fauna, suggesting that these features are likely to be used by foraging bats. Treelines and hedgerow are used for commuting purposes, and open areas are used for feeding by certain species.
- 8.7 Hazel dormice are associated with well-defined, connected hedgerows that link to further suitable habitat elsewhere in the landscape. No evidence of dormice was recorded during the survey. A dormouse tube was noted within the woodland to the north of the site, this was not inspected as a licenced individual was not present. No records of dormice were returned from the record search within 1km of the site. Hedgerows on site connect to the northern woodland, and to small woodland patches in the surrounding area.
- 8.8 No evidence of badger was noted during the survey, such as setts, footprints, hairs, latrines or other indicators of their presence. Badgers are highly mobile and can range great distances, favouring sloping ground in wooded areas where they can dig their setts and forage away from disturbance. An area of woodland is present to the north of the site. Holes were noted at the edge of the field and woodland, these were identified as a result of rabbit, due to size and presence of droppings.
- 8.9 Survey was undertaken outside of the bird nesting season, as such, no nesting activity was observed. Habitats on site, namely hedgerows and scattered trees are suitable for nesting birds.
- 8.10 Species such as otter, white-clawed crayfish (*Austropotamobius pallipes*) and water vole (*Arvicola amphibius*) are highly reliant on water bodies. No water bodies are present on, or immediately adjacent to the site. The site is not considered suitable for either of these species.

## 9 Discussion and Conclusions

- 9.1 An areas of land to the rear of Langley Close is being considered to be developed as a GRT site. Suitability surveys are currently being undertaken, consequently no design plans are available at the time of writing this report. The land subject to survey currently comprises large areas of bare ground that is heavily disturbed by livestock and farm vehicles. Less disturbed areas of the site include semi-improved grassland, which is species poor. Boundary features include species poor hedgerow, some of which features scattered trees. The band of woodland to the north has a range of species, and understory cover of ivy and bramble. Although large areas of bare ground provide little ecological value, the woodland and hedgerow on site provide a moderate level of value to wildlife.
- 9.2 Habitat on site is not considered suitable for reptiles or amphibians, given the lack of shelter provided by the short sward, grazed grassland, and large areas of bare ground due to the presence of cattle, horses and farm vehicles. There are no ponds present on site, or within 500m of the site, and no amphibian records were returned within 1km of the site. A single grass snake record was returned around 700m from the site, however onsite habitat does not provide enough shelter or other opportunities for this species.
- 9.3 Detailed assessment of the trees on site was not undertaken. A single tree was noted during the survey as having features that may be suitable for roosting bats, although depth and suitability of features were not thoroughly inspected. If any trees are earmarked for removal, further assessment is required.
- 9.4 No dormouse records have been returned within 1km of the site. A dormouse survey tube was noted within the woodland to the north, although an inspection of the tube was not made, as the surveyor does not have an appropriate licence. This woodland habitat is suitable for dormouse given the presence of hazel, and woodland floor coverage with ivy and bramble. The woodland is connected to hedgerows on site. It is highly recommended that all woodland, trees and hedgerow on site are retained and protected, some hedgerow may however require removal at the site entrance. If only a short section of hedgerow removal is required, this can be carried out under an ecological method statement which outlines precautionary working methods to ensure no impacts to dormice. If larger areas are to be removed, then further survey for dormouse will be required.
- 9.5 No live badgers were recorded during the survey, although the woodland habitat to the north is suitable for this species. Badger has been recorded over 900m from the site, therefore passage through the site and use of the woodland to the north cannot be discounted. If any works are proposed to the northern woodland, further targeted survey will be required. If no impacts to the

woodland are anticipated then appropriate precautionary measures must be taken during the construction to ensure any mammals that may pass through the site are protected during the works.

- 9.6 Habitat such as trees and hedgerow provides suitable habitat for birds to nest. All nesting birds, their chicks, eggs and nests whilst in use are protected under the Wildlife and Countryside Act 1981 (as amended). Recommendations for best practices regarding nesting birds are made below.

## 10 Recommendations

- 10.1 If no impacts are proposed to the woodland, trees and hedgerow on site, no further survey is required at the site, at this time. Impacts include lighting and damage to hedgerow, tree and woodland root zones. It is highly recommended that all trees, hedgerow and woodland on site are retained and safeguarded as part of the proposals, as this will help in retaining some ecological value on site. If any trees and/or hedgerows are proposed to be removed, further survey will be required, by way of an assessment to determine suitability for roosting bats, and likely presence/absence of dormouse. If, as mentioned above, only a small section of hedgerow is to be removed, for reasons such as access at the site entrance, then such works can be carried out under an ecological method statement. This will outline a procedure of works to safely remove hedgerow without impacting dormouse.
- 10.2 Recommendations below include enhancing the existing hedgerow/trees on site through planting. If any vegetation is to be cut down, it must be removed outside of the bird nesting season, which runs between March and August, inclusive. If, whilst the vegetation is being removed an active nest is discovered, all works within a 2m radius of the nest must be immediately stopped, and not recommenced until all chicks have fledged.
- 10.3 To protect any mammals that may pass through the site, any trenches dug forming part of the groundworks must be covered overnight, or left with a 45° sloping side to prevent any animal from becoming trapped. Similarly, any unconnected pipes must be capped overnight to prevent any animal from becoming stuck.
- 10.4 Potential presence of nocturnal animals, such as foraging bats on site requires considerate design of a sensitive lighting scheme. Any new lighting columns must not exceed 4m in height, and must be affixed with cowls, hoods or shrouds to minimise upward light spill. Luminosity will be limited to the absolute minimum required by Health and Safety standards, and will ideally be timed to be extinguished for as long a period as possible during the night. All lights must face downwards and must not point directly at any natural features. This is also important for any temporary lighting installed for use during construction. Any external lighting affixed to the exterior of the proposed houses must be motion-activated and pointed in a downward facing direction, away from natural features. Any new lighting installed must adhere to the ILP (2023) guidelines for artificial lighting.
- 10.5 Works provide the opportunity to enhance the biodiversity of the site, and to comply with Planning Policy Wales 11 (PPW11). Areas of the site must be set aside for wildlife. The site would benefit from the creation of a pond or SuDS area (if required), the margins and surrounding areas of which must be left to grow. Woodland planting is recommended to extend the width of the woodland band to the north. Standing and fallen deadwood must be left in situ. Hedgerow and tree planting is recommended around the field margins to enhance existing defunct hedgerow, and improve connectivity across the site and to the wider landscape. Table 3 below includes a list of suitable native tree and hedgerow species, which can be planted as part of the proposals. Species used must be native, with a mix of at least five different species. It is essential that such plants are sourced locally in order to reduce likelihood of importing diseases. It is recommended that a strip of vegetation alongside the hedgerows is left to grow rank (at least 1m wide), this will provide additional shelter and add to the mix of habitats to be created at the site.

**Table 3: Recommended Native Tree and Shrub Species**

Common Name	Scientific Name
Beech	<i>Fagus sylvatica</i>
Blackthorn	<i>Prunus spinosa</i>
Crab apple	<i>Malus sylvestris</i>
Dogwood	<i>Cornus sanguinea</i>
Downy birch	<i>Betula pubescens</i>
Elder	<i>Sambucus nigra</i>
Field maple	<i>Acer campestre</i>
Common hawthorn	<i>Crataegus monogyna</i>
Hazel	<i>Corylus avellana</i>
Holly	<i>Ilex aquifolium</i>

Pedunculate oak	<i>Quercus robur</i>
Sessile oak	<i>Quercus petraea</i>
Silver birch	<i>Betula pendula</i>
Spindle	<i>Euonymus europaeus</i>

- 10.6 Bird boxes and bat boxes are an effective way of attracting species to the site. At least six woodcrete/woodstone bird boxes are recommended to be installed at the site. Bird boxes are proposed to be of different designs, including; Vivara Pro Serville 32mm Woodstone nest boxes, and Vivara Pro Barcelona Woodstone Open nest boxes (or similar). Bird boxes must be approximately 3m above the ground, with a clear flight path. Boxes must be sheltered from prevailing wind, rain and strong sunlight. Bird boxes must not be positioned too close together, and must be attached to the trees on site.
- 10.7 With regard to enhancement bat boxes, it is recommended to install six bat boxes of different designs, including Schwegler 2F bat boxes (or similar), eco Kent bat boxes (or similar) and Vincent Pro bat box (or similar), on trees within the site. These are to be installed close to natural linear features such as trees adjacent to hedgerows, and away from any artificial light source. Boxes must be at least 4m above the ground and sheltered from strong winds (usually south, south-east or south-west elevations).
- 10.8 It is important to implement good horticultural practice in any landscaping scheme, including the use of peat-free composts, mulches and soil conditioners. The use of pesticides (i.e. herbicides, insecticides, fungicides and slug pellets etc) must be discouraged to prevent cumulative fatal effects to animals via the food chain, particularly invertebrates, birds and/or mammals. Any pesticides used must be non-residual.
- 10.9 Any fencing must have a continuous gap of approximately 20cm beneath it, to ensure wildlife can continue to move across the site.

## 11 Bibliography

Anon. (2023). 'Bats and Artificial Lighting in the UK: Guidance Note 08/23'. The Institution of Lighting Professionals and Bat Conservation Trust, Rugby

Joint Nature Conservation Committee (1993). '*Handbook for Phase 1 Habitat Survey – A Technique for Environmental Audit*'. JNCC, Peterborough

Mitchell-Jones A.J. and McLeish A.P. (2004). '*The Bat Workers Manual, 3<sup>rd</sup> Edition*', English Nature, Peterborough

Rose, F. (1981). '*The Wild Flower Key*'. Frederick Warne, London

Streeter, D. (2009). '*Collins Flower Guide*'. Harper Collins, London

## Appendix I: Site Location Plan

Figure 1: Site location plan

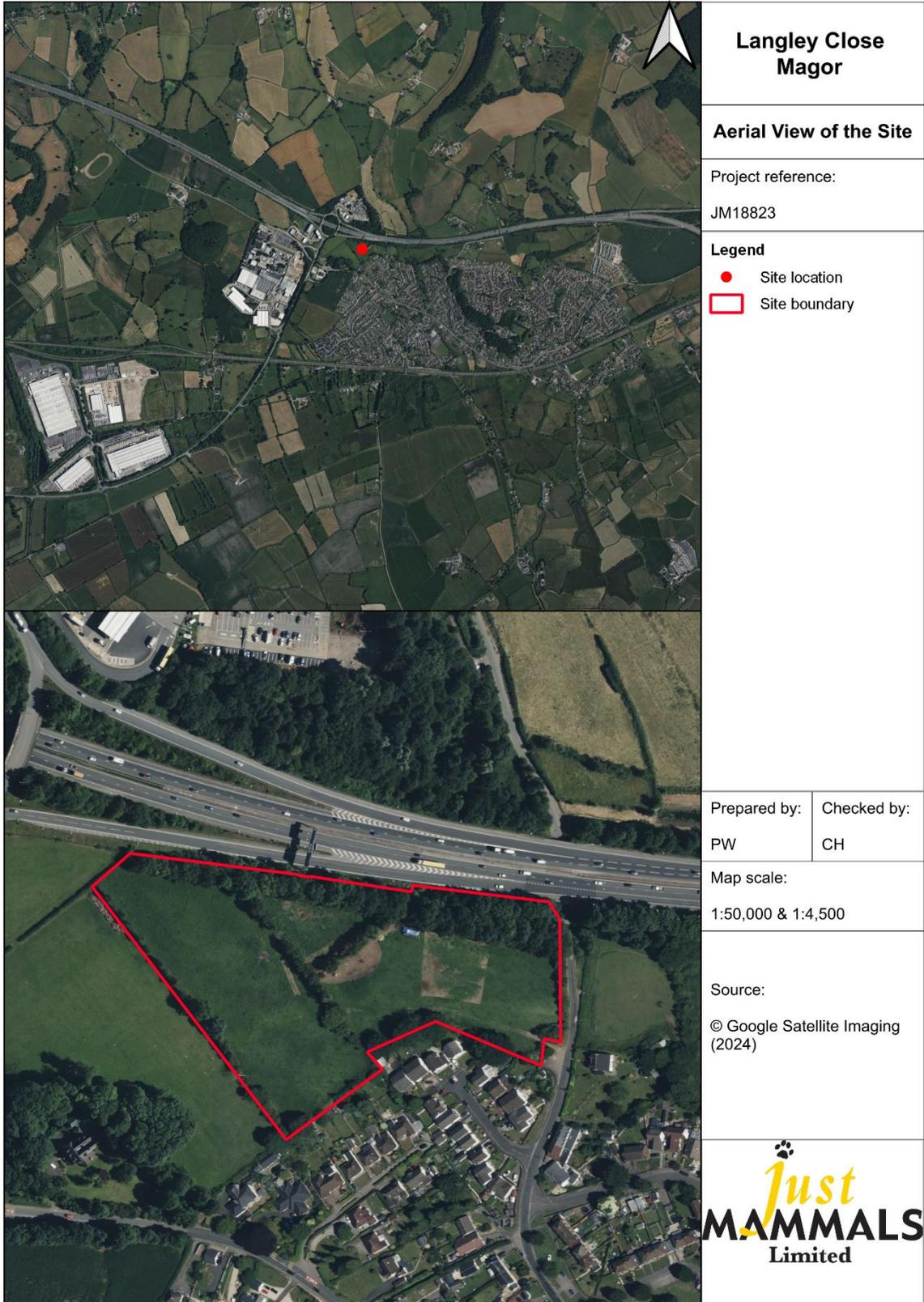

## Appendix II: Site Photographs

Plate 1: Looking north, at western end of site



Plate 2: Looking towards the north-west corner of the site



Plate 3: Hedgerow and cattle within the northern end of the site



Plate 4: Looking east across the site



Plate 5: Woodland at the northern end of the site



Plate 6: Looking west across the site



Plate 7: Woodland to the north of the site

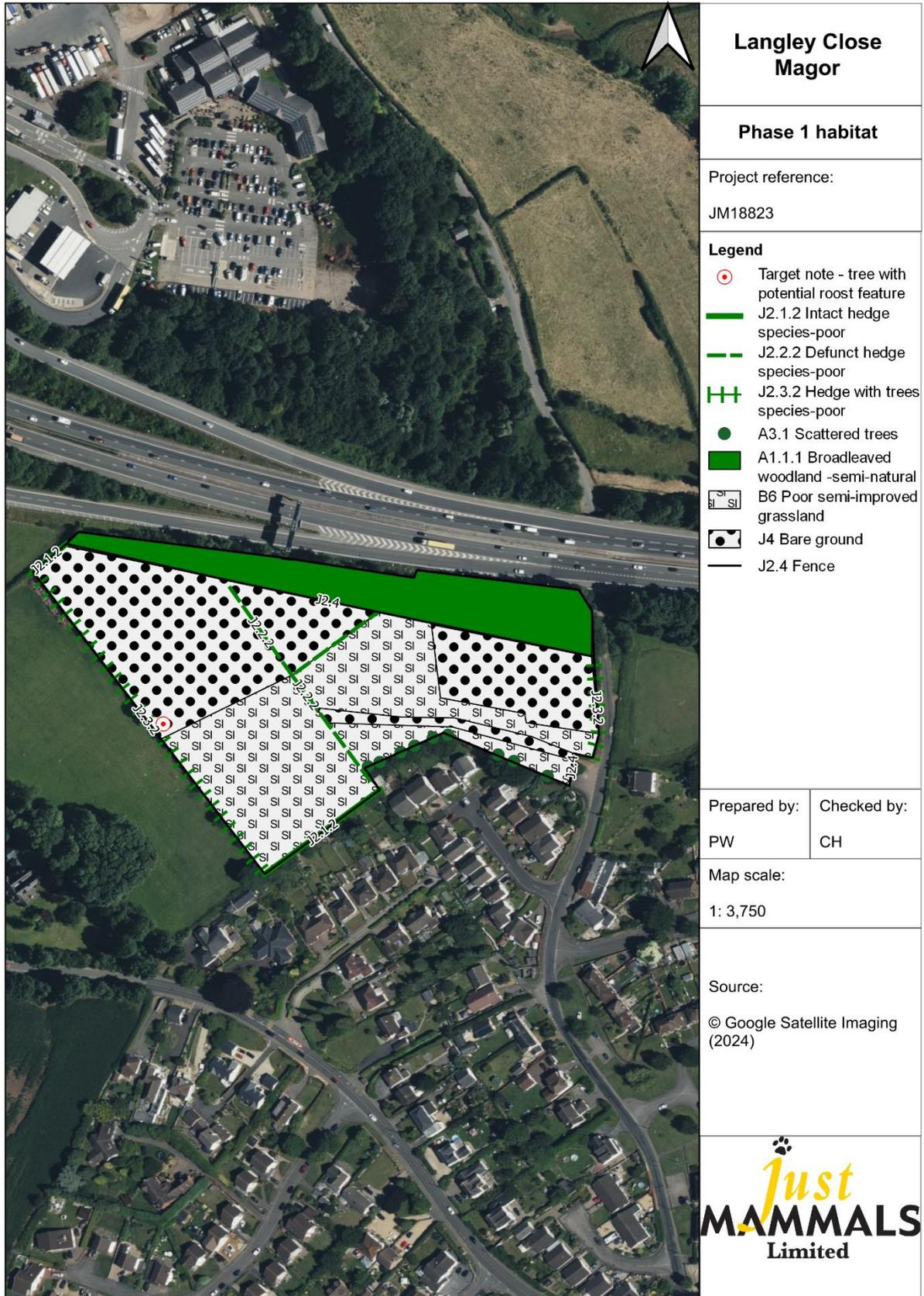

Plate 8: Target note 1, tree with potential roost feature



### Appendix III: Phase 1 Habitat Map

Figure 2: Phase 1 habitat survey map





## Appendix IV: Relevant Legislation

### Wild birds

All wild birds, their eggs and nests are protected by The Wildlife and Countryside Act 1981 (as amended). It is an offence, with certain exceptions, to:

- intentionally kill, injure or take any wild bird;
- intentionally take, damage or destroy the nest of any wild bird while it is in use or being built;
- intentionally take or destroy the egg of any wild bird;
- sell wild birds or put them on display for sale;
- use traps or similar items to kill, injure or take wild birds; and
- intentionally, or recklessly disturb any wild bird listed on Schedule 1 while it is nest building, or at a nest containing eggs or young, or disturb the dependent young of such a bird.

Penalties that can be imposed for criminal offences in respect of a single bird, nest or egg contrary to the Wildlife and Countryside Act 1981 (as amended) is an unlimited fine, up to six months imprisonment or both. In exceptional cases NRW and Natural England issues licences for specific purposes, so that legitimate work may be undertaken without breaking the law.

This document has been produced by Just Mammals Limited for Monmouthshire County Council. It may not be used by any person for any other purpose other than that specified without the express written permission of Just Mammals Limited. Any liability arising out of use by a third party of this document, for purposes not wholly connected with the above, shall be the responsibility of that party, who shall indemnify Just Mammals Limited against all claims, costs, damages, and losses, arising out of such use.

Unless specifically assigned or transferred within the terms of agreement, the consultant asserts and retains all Copyright, and other Intellectual Property Rights, in and over the document and its contents.

We confirm that in preparing this document we have exercised reasonable skill and care, taking into account the project objectives, the agreed scope of the work, prevailing site conditions, the degree of manpower and resources allocated to the project, and in compliance with the Chartered Institute of Ecology and Environmental Management's Code of Professional Conduct.

Just Mammals Limited is an ecological consultancy based in Mid-Wales. Specialising in legally protected mammal, reptile and amphibian species, but providing a wide range of ecological services, it provides appropriate expertise on behalf of a range of clients.

Clients include government departments, local and regional authorities, development agencies, commercial and industrial enterprises as well as statutory nature conservation organisations, wildlife trusts and other charitable bodies.

Please visit our web site [www.justmammals.co.uk](http://www.justmammals.co.uk) to see the full range of services we offer and some of the projects we have undertaken in the past.



## **Natural Problem Solvers**

Just Mammals Limited, Suite 131-136, Plas y Ffynnon, Cambrian Way, Brecon  
LD3 7HP Tel: 01874 623616

This page is intentionally left blank

Bradbury Farm  
**Crick**  
**Monmouthshire**  
**NP26 5UW**

A **Preliminary Ecological**  
**Appraisal By:**



  
*Just*  
**MAMMALS**  
Limited  
Ecological Consultancy

On **Behalf Of:**



February **2024**

File Reference: **JM18923**

Status	Name	Position	Date
Co-author	Catherine Povey BSc (Hons) MSc	Trainee Ecologist	5 <sup>th</sup> February 2024
Co-author	Phoebe Williams BA (Hons) MSc	Ecologist	6 <sup>th</sup> February 2024
Reviewer	Carola Hoskins BA (Hons) MSc ACIEEM	Principal Ecologist	8 <sup>th</sup> February 2024
Valid until	12 <sup>th</sup> January 2026		

**Directors:** Carola Hoskins BA (Hons) MSc ACIEEM Robert Morgan Phoebe Williams BA (Hons) MSc  
**Registered Office:** Suite 131 -136, Plas y Ffynnon, Cambrian Way, Brecon LD3 7TG  
**Web Site:** [www.justmammals.co.uk](http://www.justmammals.co.uk) **Email:** [phoebe@justmammals.co.uk](mailto:phoebe@justmammals.co.uk) **Telephone:** 01874 623616  
**Registered In:** Wales **Registration Number:** 13099914 **VAT No:** 821 6376 35

## Contents

	<b>Page No.</b>	
<b>1</b>	<b>Executive Summary</b>	<b>1</b>
<b>2</b>	<b>Introduction</b>	<b>1</b>
<b>3</b>	<b>Survey Team Experience</b>	<b>1 - 2</b>
<b>4</b>	<b>Survey Methodology</b>	<b>2</b>
<b>5</b>	<b>Site Description</b>	<b>2</b>
<b>6</b>	<b>Desktop Study</b>	<b>2 – 3</b>
<b>7</b>	<b>Survey Constraints</b>	<b>3</b>
<b>8</b>	<b>Survey Results</b>	<b>3 – 4</b>
<b>9</b>	<b>Discussion and Conclusions</b>	<b>4 – 5</b>
<b>10</b>	<b>Recommendations</b>	<b>5 – 7</b>
<b>11</b>	<b>Bibliography</b>	<b>7</b>
	<b>Appendix I: Site Location Plan</b>	<b>8</b>
	<b>Appendix II: Site Photographs</b>	<b>9</b>
	<b>Appendix III: Phase 1 Habitat Map</b>	<b>10</b>
	<b>Appendix IV: List of Recorded Species</b>	<b>11</b>
	<b>Appendix V: Relevant Legislation</b>	<b>12</b>

### List of Tables

Table	Description of Contents	Page No.
Table 1	Summary of Survey Activity and Weather Conditions	3
Table 2	Summary of Phase 1 Habitat Notes	3 - 4
Table 3	Recommended Native Tree and Scrub Species	6
Table 4	Recommended Native Flowering Plants	6
Table 5	List of Recorded Species	12

### List of Figures

Figure	Description of Contents	Page No.
Figure 1	Site location plan	9
Figure 2	Phase 1 habitat survey map	11

### List of Plates

Plate	Description of Contents	Page No.
Plate 1	Looking north-east towards Ballan Wood	10
Plate 2	Looking north along the western boundary	10
Plate 3	Looking north-east along the boundary	10
Plate 4	Looking south-east towards Ballan Wood	10
Plate 5	Looking along the boundary to the south-east	10
Plate 6	Looking to the south-west	10
Plate 7	Looking north-west towards the M48	10
Plate 8	Pedunculate oak on the southern boundary	10

## 1 Executive Summary

- 1.1 A suitability assessment of various sites in Monmouthshire is being carried out by Monmouthshire County Council, for the possible creation of Gypsy Roma Traveller Sites, to be included within the Replacement Local Development Plan. An area of land within Bradbury Farm, just off Crick Road, Crick, forms part of the suitability assessment. To support the proposals, a Preliminary Ecological Appraisal of the land was conducted in January 2024, by an ecologist and an assistant.
- 1.2 Bradbury Farm is situated approximately 2km north-east of Caldicot. The site subject to survey comprises a single agricultural field of approximately 1.5 ha. The field is bounded by roads on two sides; the M48 motorway to the north, and Crick Road to the west. At the north end of the site stretches a thin woodland band, somewhat connected to hedgerow boundaries which run along the western and southern sides of the field. The eastern field boundary comprises a newly planted hedgerow. The surrounding landscape is typically rural and primarily characterised by agricultural land. There is a solar farm to the east, separated from the site by Ballan Wood.
- 1.3 Protected species and their potential presence on site were considered as part of the assessment. If no impacts to the woodland, trees or hedgerow on site are anticipated, then no further survey is required at this time. It is recommended that these features on site are retained and safeguarded as part of the proposals, as this will help in retaining ecological value on site. If impacts to the features cannot be avoided, then further survey will be required, by way of assessment to determine suitability of trees for roosting bats, and likely absence/presence of dormice within the northern woodland and connecting hedgerow. Recommendations are provided in this report.
- 1.4 Breeding birds are likely to be present on site, due to the suitability of habitat. Breeding birds and all results of their breeding activities are protected under the Wildlife and Countryside Act 1981 (as amended). Although the majority of onsite hedgerows, woodland and tree lines are to be retained, removal of a section of hedgerow may be required for access. Any removal of vegetation must be timed outside of the breeding season for birds, and likely under a method statement in order to account for the potential presence of hazel dormouse.
- 1.5 Enhancements for biodiversity and green infrastructure are required to meet the planning policy as indicated by Planning Policy Wales 11 and Future Wales, policy documents. This report makes recommendations to provide enhancements for biodiversity on site, including the installation of bird and bat boxes, as well as planting of hedgerows.

## 2 Introduction

- 2.1 A field at Bradbury Farm in Crick, Monmouthshire is being considered by Monmouthshire County Council (MCC) as part of their Gypsy Roma Traveller (GRT) Site Identification. To support the work, Just Mammals Limited was commissioned to carry out a Preliminary Ecological Assessment (PEA) of the site, as part of the suitability assessment. The site subject to survey comprises a single agricultural field centred on National Grid Reference ST 48988 89845, standing at an altitude of 15m Above Ordnance Datum. An initial assessment of the site was undertaken in 2020, this assessment was updated by a survey on the 12<sup>th</sup> January 2024.
- 2.2 This report makes recommendations concerning the ecological value of the site, as well as the need for further survey work as appropriate. The different types of habitat were assessed, and the potential presence of protected species, such as badger (*Meles meles*), otter (*Lutra lutra*), dormouse (*Muscardinus avellanarius*), reptiles and amphibians, as well as bats and nesting birds was considered. Section 7 species such as hedgehog (*Erinaceus europaeus*) were also considered.

## 3 Survey Team Experience

- 3.1 Undertaking the assessment was Phoebe Williams. A Geography graduate from the University of Exeter, and a former trainee at Gwent Wildlife Trust she has completed a Natural Talent trainee programme, studying Hemiptera at the National Museum of Wales. Practical experience includes survey work for dormice, botany, newts, reptiles, and invertebrates. Phoebe has undertaken an MSc in Wildlife and Conservation Management at the University of South Wales. She is an ecologist with Just Mammals Limited. Phoebe holds a Great crested newt (NRW) S092295/1 (expiry 26th February 2025) and is an accredited agent on NRW bat licence S091842/2 (expiry 10<sup>th</sup> November 2024).



- 3.2 Assisting with the survey effort was Catherine Povey. After graduating from Swansea University and UCL Catherine worked in medical research and as a practitioner. Since the first year of her degree when she studied Zoology and Botany, she has retained a keen interest in the natural world and has worked with Bannau Brycheiniog National Park on a number of projects, including peat conservation. She is employed by Just Mammals Limited as a Trainee Ecologist and has conducted a variety of surveys with the company.

## 4 Survey Methodology

- 4.1 A PEA was conducted on 12<sup>th</sup> January 2024. Details of the survey and weather conditions are provided in Table 1. Prior to the site visit, a desktop study was undertaken, which involved a standard search area of a 2km radius from the site (using a central grid reference), using the MAGIC website. Details of statutory sites designated for nature conservation were obtained. A record search was also commissioned from South East Wales Biodiversity Records Centre (SEWBRc).
- 4.2 The assessment comprised a survey employing the Phase 1 habitat survey methodology. This is a standardised technique for classifying and mapping British habitats. All areas within the site were inspected and assessed for indicators of ecological value, including the presence and/or field signs of any protected or rare habitats and species. The site was walked over, recording all plant species and features onto a custom-made recording sheet. Habitats and notes were drawn onto a map of the survey site and photographs were taken. A coloured Phase 1 habitat map was produced (Appendix III).
- 4.3 Assessment for the presence or potential absence of other protected species, including hazel dormouse, badger, reptiles and amphibians, was undertaken by considering the features of the site. Such features include grassland and dense vegetation. The potential suitability of the site for nesting birds was also considered.

## 5 Site Description

- 5.1 Bradbury Farm is situated approximately 2km north-east of Caldicot. The site subject to survey comprises a single pastoral field of approximately 1.5 ha. The field is bounded by roads on two sides; the M48 motorway to the north, and Crick Road to the west. To the north of the site stretches a thin woodland band, somewhat connected to hedgerow boundaries which run along the western and southern sides of the field. The eastern field boundary comprises a newly planted hedgerow. The surrounding landscape is typically rural and primarily characterised by agricultural land. There is a solar farm present to the east, separated from the site by Ballan Wood.

## 6 Desktop Study

- 6.1 A record search was commissioned from South East Wales Biological Records Centre (SEWBRc) (unique reference 0234-699) to ascertain whether protected species have been recorded at or close to the site. The search revealed no records of priority species at the site.
- 6.2 The data set revealed protected species records within 2km of the site. The record search is summarised below:
- Mammals (terrestrial) accounted for 85 records, species include; hazel dormouse (*Muscardinus avellanarius*) approximately 250m and 300m away, harvest mouse (*Micromys minutus*) approximately 270m away, stoat (*Mustela erminea*) and brown hare (*Lepus europeus*) approximately 280m away and badger (*Meles meles*) approximately 300m and 350m away. Within 500m of the site are records for common and soprano pipistrelle (*Pipistrellus pipistrellus* and *Pipistrellus pygmaeus* respectively), noctule (*Nyctalus noctula*) and brown long-eared bat (*Plecotus auritus*). Within 500m of the site on the M48 there are records of road mortalities - five for badger, one each for otter (*Lutra lutra*) and polecat (*Mustela putorius*);
  - Within 2km of the site birds accounted for 329 records including birds on Schedule 1 of the Wildlife & Countryside Act 1981, Section 7 of the Environment (Wales) Act 2016 and the Birds of Conservation Concern Red List. Many of these were recorded at Nedern Brook Wetlands SSSI. Outside of the SSSI and within 500m of the site, species of note include; hawfinch (*Coccothraustes coccothraustes*), lesser spotted woodpecker (*Dryobates minor*), swift (*Apus apus*), grey wagtail (*Motacilla cinerea*) and kestrel (*Falco tinnunculus*);

- Reptiles and amphibians accounted for 9 records, the closest reptile record to the site being grass snake (*Natrix helvetica*) within 200m. Species recorded within 2km include adder (*Vipera berus*), common toad (*Bufo bufo*), common frog (*Rana temporaria*);
  - Invertebrates accounted for 69 records within 2km of the site. Within 250m are records for long-winged conehead (*Conocephalus fuscus*) and brindled beauty (*Lycia hirtaria*). All other records are over 500m away from the site;
  - Vascular plants include 180 records, There are records for wood spurge (*Euphorbia amygdaloides*) and spurge laurel (*Daphne laureola*) within 250m. A stand of Japanese knotweed (*Fallopia japonica*) is recorded less than 500m north-east of the site. All other records are more than 500m away.
- 6.3 By consulting Magic Map, it was determined that no part of the site contains, or is within, any statutory sites of nature conservation interest, such as Sites of Special Scientific Interest (SSSI), Special Areas of Concern (SAC), National Nature Reserve (NNR) or Local Nature Reserves (LNR) etc. Nedern Brook Wetlands, Caldicot SSSI is less than 300m away and is the only statutory site with 2km of the site.
- 6.4 The record search also revealed Sites of Importance for Nature Conservation (SINC) within 1km of the site under survey. These are listed below with significance of the sites also included, where information is available:
- Priest Wood – Ancient Semi-natural Woodland (ASNW) approximately 1km north-east of the site;
  - Little Wood – ASNW approximately 800m north-west of the site;
  - Sunny Bank – ASNW approximately 500m north-east of the site;
  - Ballan Wood – a combination of ASNW and a Restored Ancient Woodland Site (RAWS) less than 100m east of the site;
  - A National Resources Wales (NRW) Heathland and Grassland Priority Area approximately 1 km north of the site;
  - The site falls within the B-Lines network for Wales, a non-statutory designation concerned with the impact of development on pollinators.
- 6.5 Given the scale of the development and the distance of sites of conservation interest from the site subject to assessment, it is considered unlikely that proposals will impact designated sites within the surrounding area at this time.

## 7 Survey Constraints

- 7.1 The comprehensiveness of any ecological assessment may be limited by the nature of the site visit, it being a single snapshot of the site at any point in time. This report cannot therefore be considered to provide a fully comprehensive analysis of the ecological interest of the site. However, it does provide an ecological assessment of the site for supporting habitats and species on the day of the visit and highlights areas where further survey work may be required.

## 8 Survey Results

- 8.1 Details of the conditions under which survey was conducted is given in Table 1. Wind speeds given employ the Beaufort scale.

**Table 1: Summary of Survey Activity and Weather Conditions**

Survey Type and Location	Dates	Timing	Weather Conditions
Day time visual inspection, botanical survey and habitat assessment, including protected species assessment	12/01/2024	12.30 – 13.00 hours Greenwich Mean Time	Air temperature: 5°C Cloud cover: 8/8 oktas Wind speed: F3, gentle breeze Conditions: Dry
<b>Surveyors</b>	Phoebe Williams and Catherine Povey		

- 8.2 The site was divided into six different types of habitat for recording purposes. Table 2 below provides details of the various habitats and the dominant species for each of them.

**Table 2: Summary of Phase 1 Habitat Notes**

Habitat	Phase 1 Classification	Description of Area and Typical Species
Type 1	B6 Poor semi-improved grassland	The majority of the land is made up of this habitat and comprises a low diversity of forb species. Grassland sward is short and grazed by sheep.

		Species present include annual meadow grass ( <i>Poa annua</i> ), creeping buttercup ( <i>Ranunculus repens</i> ), Yorkshire fog ( <i>Holcus lanatus</i> ), and clover ( <i>Trefoil sp.</i> ).
Type 2	A1.1.1 Broadleaved woodland	The habitat to the north of the site is a small strip of woodland, immediately north of which stretches the M48 motorway.  Species present include sycamore ( <i>Acer pseudoplatanus</i> ), hard fern ( <i>Blechnum spicant</i> ), ivy ( <i>Hedera helix</i> ), ash ( <i>Fraxinus excelsior</i> ), hazel ( <i>Corylus avellana</i> ).
Type 3	A3.1 Scattered trees	A small number of mature trees stand at the site boundaries. Species include pedunculate oak ( <i>Quercus robur</i> ).  <b>Target note 1: Pedunculate oak with potential roost feature</b>
Type 4	J2.1.2 Intact hedgerow, species poor	This habitat stretches along the eastern field edge. The hedgerow is <2m wide and <2m in height. It is a newly planted hedgerow.  Species include; rose ( <i>Rosa sp.</i> ), blackthorn ( <i>Prunus spinosa</i> ) and hawthorn ( <i>Crataegus monogyna</i> ).
Type 5	J2.2.2 Defunct hedgerow	The land is bounded on the southern and western sides by this habitat. The hedgerow is gappy and defunct, generally <1m wide and <2m in height.  Species include hawthorn, hazel and holly ( <i>Ilex aquifolium</i> ).
Type 6	J2.4 Fence	Post and barbed wire fencing runs along the easterly and southerly boundaries with timber fencing bounding the northerly and westerly sides.

- 8.3 A coloured Phase 1 habitat map was produced (see Appendix III). A total of 28 species of plants were recorded during the survey, these are listed in Appendix IV.
- 8.4 Ecological assessment included identification of the potential for protected species to be present on site. Reptiles make use of open, rank habitats which provide a mixture of open areas and cover. Habitat on site comprises short sward grassland that is grazed by sheep.
- 8.5 During the terrestrial part of their lifecycle, amphibians have similar habitat requirements to reptiles, with both species' groups favouring unmanaged, rank grassland, scrubby vegetation and variation in vegetative architecture. No amphibians were noted during the survey. No ponds are present, ruling out the possibility for them to breed on site. Since great crested newts are known to use terrestrial habitat up to 500m from their breeding ponds, the wider landscape must also be taken into consideration. Review of aerial maps show a single pond approximately 450m to the south-west of the site. No other ponds are present within 500m of the site.
- 8.6 Bats use trees as well as buildings for roosting, where they will exploit gaps, cracks and crevices in the bark. An extensive survey of trees and their suitability for bats was not undertaken, as this is beyond the scope of this preliminary assessment. However, a single tree (Target Note 1) was noted as having Potential Roost Features (PRF). Features include thick ivy stems. Features were not inspected during the PEA.
- 8.7 Hazel dormice are associated with well-defined, connected hedgerows that link to further suitable habitat elsewhere in the landscape. No evidence of dormice was recorded during the survey. Most of the hedgerow on site is gappy and species poor. On site hedgerows and the woodland to the north are connected to Ballan Wood, situated just east of the site.
- 8.8 No evidence of badger was noted during the survey, such as setts, footprints, hairs, latrines or other indicators of their presence. Badgers are highly mobile and can range great distances, favouring sloping ground in wooded areas where they can dig their setts and forage away from disturbance. No dense areas of woodland are present on site. Ballan Wood is present to the east of the site, less than 100m away.
- 8.9 Survey was undertaken outside of the nesting season, as such, no nesting activity was observed. Habitats on site, namely hedgerow and scattered trees are suitable for nesting birds.
- 8.10 Species such as otter, white-clawed crayfish (*Austropotamobius pallipes*) and water vole are highly reliant on water bodies. No water bodies are present on, or immediately adjacent to the site. The site is not considered suitable for any of these species.

## 9 Discussion and Conclusions

- 9.1 An area of land that makes up part of Bradbury Farm is being included in a suitability assessment as a potential GRT Site. The land subject to survey currently comprises semi-improved, species-poor grassland. Boundary features include species-poor hedgerow, few scattered trees and a small strip of broadleaf woodland to the north. Overall, the site subject to survey is assessed as having a moderate level of ecological value, due to the presence of hedgerow, woodland and trees.
- 9.2 Habitat on site is not considered suitable for reptiles or amphibians, given the lack of shelter and foraging opportunities provided by the short sward, grazed grassland. There is a pond present approximately 450m to the south-west, however this is not well connected to the site due to the presence of surrounding open, agricultural fields and the lack of connecting features. Amphibian records in the area are around 450m from the site, there include common toad and common frog. No great crested newt records were returned from the data search. The closest reptile record returned from the record search was of a grass snake, within 200m of the site. However, this was recorded at the northern side of the M48, and not well connected to the site. It is therefore considered unlikely that the site is used by amphibians and reptiles at this time.
- 9.3 Detailed assessment of the trees on site was not undertaken. A single tree were noted during the survey as having features that may be suitable for roosting bats, although depth and suitability of features were not thoroughly inspected. If any trees are earmarked for removal, further assessment is required. Recommendations are made below.
- 9.4 Evidence to suggest the presence of dormice has been found within Ballan Wood, to the east of the site. There are hedgerows present on site which are connected to Ballan Wood, although these are mostly gappy. The presence of dormice within the hedgerows cannot be ruled out. It is recommended that hedgerow on site is retained and enhanced, recommendations for which are made below. If a small section of hedgerow is to be removed to provide access for example, then works must be carried out under an ecological method statement, to outline precautionary working measures to ensure no impacts to dormouse. If larger areas of hedgerow and any impacts to the northern woodland are proposed, then further targeted survey will be required.
- 9.5 No live badgers were recorded during the survey and no features of interest are present on site for this species. However, badger records have been returned from Ballan Wood to the east, and road mortalities on the M48 to the north have been recorded suggesting that occasional passage through the site by badgers is possible. Appropriate precautionary measures must be taken to ensure mammals are protected during construction works.
- 9.6 Habitats such as trees and hedgerow provides suitable habitat for birds to nest. All nesting birds, their chicks, eggs and nests whilst in use are protected under the Wildlife and Countryside Act 1981 (as amended). Recommendations for best practices regarding nesting birds are made below.
- 9.7 The site falls within the B-Lines network for Wales, a non-statutory designation concerned with the impact of development on pollinators. The site features no habitat that is of significance to invertebrates, due to the heavily grazed grassland. Therefore further survey for invertebrates is not recommended at this time. Recommendations to enhance the site for pollinators are made below.

## 10 Recommendations

- 10.1 If no impacts are proposed to the woodland, trees and hedgerow on site, no further survey is required at this time. Impacts include lighting and protection of hedgerow, tree and woodland root zones. It is highly recommended that all trees, hedgerow and woodland on site are retained and safeguarded as part of the proposals, as this will help in retaining some ecological value on site. If any trees and/or hedgerows are proposed to be removed, further survey will be required, by way of an assessment to determine suitability for roosting bats, and likely presence/absence of dormouse. If, as mentioned above, only a small section of hedgerow is to be removed, for reasons such access at the site entrance, then such works can be carried out under an ecological method statement. This will outline a procedure of works to safely remove a small section of hedgerow without impacting dormouse.
- 10.2 Recommendations below include enhancing the existing hedgerow on site, through planting. If any vegetation is to be cut down, it must be removed outside of the bird nesting season, which runs between March and August, inclusive. If, whilst the vegetation is being removed an active nest is discovered, all works within a 2m radius of the nest must be immediately stopped, and not recommenced until all chicks have fledged.

- 10.3 To protect any mammals that may pass through the site, any trenches dug forming part of the groundworks must be covered overnight or left with a 45° sloping side to prevent any animal from becoming trapped. Similarly, any unconnected pipes must be capped overnight to prevent any animal from becoming stuck.
- 10.4 Potential presence of nocturnal animals, such as foraging bats on site requires considerate design of a sensitive lighting scheme. Any new lighting columns must not exceed 4m in height, and must be affixed with cowls, hoods or shrouds to minimise upward light spill. Luminosity will be limited to the absolute minimum required by Health and Safety standards and will ideally be timed to be extinguished for as long a period as possible during the night. All lights must face downwards and must not point directly at any natural features. This is also important for any temporary lighting installed for use during construction. Any external lighting affixed to the exterior of the proposed houses must be motion-activated and pointed in a downward facing direction, away from natural features. Any new lighting installed must adhere to the ILP (2023) guidelines for artificial lighting.
- 10.5 Works provide the opportunity to enhance the biodiversity of the site, and to comply with Planning Policy Wales 11 (PPW11). An area of the site must be set aside as an enhancement for wildlife. This area would benefit from the creation of a small pond, the margins of which must be left to grow. Additionally, hedgerow planting is recommended around the field to enhance existing defunct hedgerows. Table 3 below includes a list of suitable native tree and hedgerow species, which can be planted as part of the proposals. Species used must be native, with a mix of at least five different species per 25m. It is essential that such plants are sourced locally in order to reduce likelihood of importing diseases. It is recommended that a strip of vegetation alongside the hedgerows is left to grow rank (at least 1m wide), this will provide additional shelter and add to the mix of habitats to be created at the site.

**Table 3: Recommended Native Tree and Shrub Species**

Common Name	Scientific Name
Beech	<i>Fagus sylvatica</i>
Blackthorn	<i>Prunus spinosa</i>
Crab apple	<i>Malus sylvestris</i>
Dogwood	<i>Cornus sanguinea</i>
Downy birch	<i>Betula pubescens</i>
Elder	<i>Sambucus nigra</i>
Field maple	<i>Acer campestre</i>
Common hawthorn	<i>Crataegus monogyna</i>
Hazel	<i>Corylus avellana</i>
Holly	<i>Ilex aquifolium</i>
Pedunculate oak	<i>Quercus robur</i>
Sessile oak	<i>Quercus petraea</i>
Silver birch	<i>Betula pendula</i>
Spindle	<i>Euonymus europaeus</i>

- 10.6 The site falls within the B-Lines network for Wales which aims to enhance and protect connectivity across the country for pollinators. To expand the pollinating season and encourage pollinators to visit the site, wildflower planting is recommended. Table 4 below includes a list of native flowering plants.

**Table 4: Recommended Native Flowering Plants**

Common Name	Scientific Name
Knapweed	<i>Centaurea nigra</i>
Kidney vetch	<i>Anthyllis vulneraria</i>
Greater knapweed	<i>Centaurea scabiosa</i>
Rough chervil	<i>Chaerophyllum temulum</i>
Smooth hawksbeard	<i>Crepis capillaris</i>
Wild carrot	<i>Daucus carota</i>
Musk mallow	<i>Malva moschata</i>
Wild marjoram	<i>Origanum vulgare</i>
Meadow crane's-bill	<i>Geranium pratense</i>

- 10.6 Bird boxes and bat boxes are an effective way of attracting species to the site. At least four woodcrete/woodstone bird boxes are recommended to be installed at the site. Bird boxes are proposed to be of different designs, including; Vivara Pro Serville 32mm Woodstone nest boxes, and Vivara Pro Barcelona Woodstone Open nest boxes (or similar). Bird boxes must be approximately 3m above the ground, with a clear flight path. Boxes must be sheltered from prevailing wind, rain and strong sunlight. Bird boxes must not be positioned too close together, and can be attached to the trees on site.

- 10.7 With regard to enhancement bat boxes, it is recommended to install three bat boxes (1FF Schwegler bat boxes, or equivalent), on trees at the site. These are to be installed close to natural linear features such as a woodland/trees, and away from any artificial light source. Boxes must be at least 4m above the ground and sheltered from strong winds (usually south, south-east or south-west elevations).
- 10.8 It is important to implement good horticultural practice in any landscaping scheme, including the use of peat-free composts, mulches and soil conditioners. The use of pesticides (i.e. herbicides, insecticides, fungicides and slug pellets etc) must be discouraged to prevent cumulative fatal effects to animals via the food chain, particularly invertebrates, birds and/or mammals. Any pesticides used must be non-residual.
- 10.9 Any fencing must have a continuous gap of 20cm beneath it to ensure wildlife can continue to move across the site.

## 11 Bibliography

Anon. (2023). 'Bats and Artificial Lighting in the UK: Guidance Note 08/23'. The Institution of Lighting Professionals and Bat Conservation Trust, Rugby

Joint Nature Conservation Committee (1993). '*Handbook for Phase 1 Habitat Survey – A Technique for Environmental Audit*'. JNCC, Peterborough

Mitchell-Jones A.J. and McLeish A.P. (2004). '*The Bat Workers Manual, 3<sup>rd</sup> Edition*', English Nature, Peterborough

Nichols, R., Goulson, D. and Holland, J. (2019). 'The best wildflowers for wild bees'. *Journal of Insect Conservation* 23, 819–830 (2019). <https://doi.org/10.1007/s10841-019-00180-8>

Rose, F. (1981). '*The Wild Flower Key*'. Frederick Warne, London

Streeter, D. (2009). '*Collins Flower Guide*'. Harper Collins, London

## Appendix I: Site Location Plan

Figure 1: Site location plan

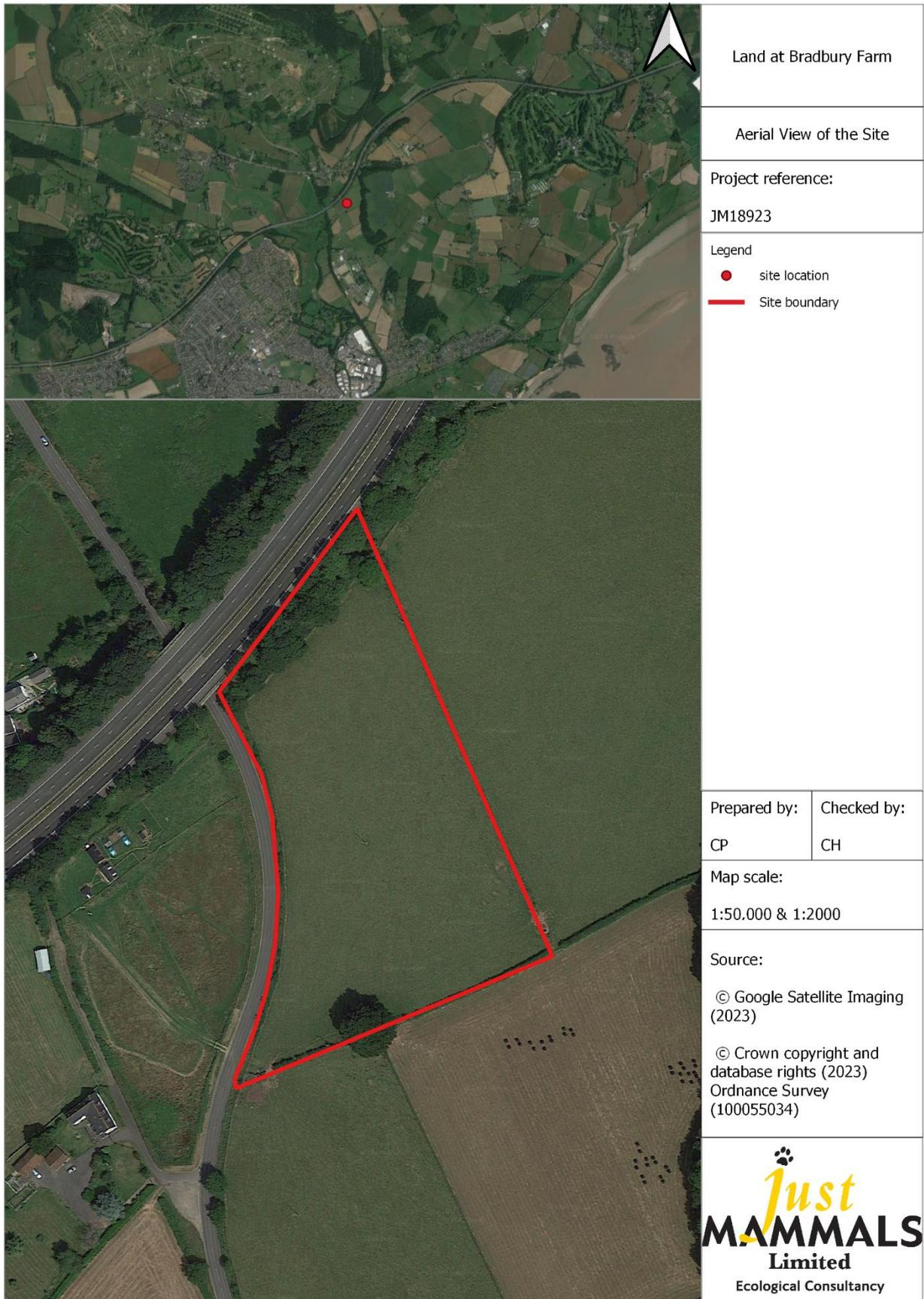



## Appendix II: Site Photographs

Plate 1: Looking north-east towards Ballan Wood



Plate 2: Looking north along the western boundary



Plate 3: Looking north-east along the boundary



Plate 4: Looking south-east towards Ballan Wood



Plate 5: Looking along the boundary to the south-east



Plate 6: Looking to the south-west



Plate 7: Looking north-west towards the M48



Plate 8: Pedunculate oak on the southern boundary



### Appendix III: Phase 1 Habitat Map

Figure 2: Phase 1 habitat survey map



## Appendix IV: List of Recorded Species

Table 5: List of Recorded Species

Plant Species		JNCC Broad Habitat Types				
Common Name	Scientific Name	B4	A3.1	A1.1.1	J2.1.2	J2.2.2
Alder	<i>Alnus glutinosa</i>			x		
Ash	<i>Fraxinus excelsior</i>			x		
Blackthorn	<i>Prunus spinosa</i>			x		
Bramble	<i>Rubus fruticosus</i>			x		
Buttercup, creeping	<i>Ranunculus repens</i>	x				
Cleavers	<i>Galium aparine</i>	x				
Clover, A	<i>Trefoil sp.</i>	x				
Common sorrel	<i>Rumex acetosa</i>	x				
Dead-nettle, Red	<i>Lamium purpureum</i>	x				
Ground ivy	<i>Glechoma hederacea</i>					
Hard fern	<i>Blechnum spicant</i>					
Hawthorn	<i>Crataegus monogyna</i>					x
Hazel	<i>Corylus avellana</i>			x		x
Hedge parsley	<i>Torilis arvensis</i>					
Herb Robert	<i>Geranium robertianum</i>					
Holly	<i>Ilex aquifolium</i>			x		x
Ivy	<i>Hedera helix</i>			x		
Meadow grass	<i>Poa annua</i>	x				
Mouse Ear	<i>Cerastium fontanum</i>	x				
Oak, pedunculate	<i>Quercus robur</i>		x			
Nettle	<i>Urtica dioica</i>					
Ragwort	<i>Jacobaea vulgaris</i>					
Red oak	<i>Quercus rubra</i>					
Rose, A	<i>Rosa sp</i>					
Shepherd's purse	<i>Capsella bursa-pastoris</i>					
Sycamore	<i>Acer pseudoplatanus</i>					
Thistle, Creeping	<i>Cirsium arvense</i>					
Yorkshire fog	<i>Holcus lanatus</i>	x				

## Appendix V: Relevant Legislation

### Wild birds

All wild birds, their eggs and nests are protected by The Wildlife and Countryside Act 1981 (as amended). It is an offence, with certain exceptions, to:

- intentionally kill, injure or take any wild bird;
- intentionally take, damage or destroy the nest of any wild bird while it is in use or being built;
- intentionally take or destroy the egg of any wild bird;
- sell wild birds or put them on display for sale;
- use traps or similar items to kill, injure or take wild birds; and
- intentionally, or recklessly disturb any wild bird listed on Schedule 1 while it is nest building, or at a nest containing eggs or young, or disturb the dependent young of such a bird.

Penalties that can be imposed for criminal offences in respect of a single bird, nest or egg contrary to the Wildlife and Countryside Act 1981 (as amended) is an unlimited fine, up to six months imprisonment or both. In exceptional cases NRW and Natural England issues licences for specific purposes, so that legitimate work may be undertaken without breaking the law.

This document has been produced by Just Mammals Limited for Monmouthshire County Council. It may not be used by any person for any other purpose other than that specified without the express written permission of Just Mammals Limited. Any liability arising out of use by a third party of this document, for purposes not wholly connected with the above, shall be the responsibility of that party, who shall indemnify Just Mammals Limited against all claims, costs, damages, and losses, arising out of such use.

Unless specifically assigned or transferred within the terms of agreement, the consultant asserts and retains all Copyright, and other Intellectual Property Rights, in and over the document and its contents.

We confirm that in preparing this document we have exercised reasonable skill and care, taking into account the project objectives, the agreed scope of the work, prevailing site conditions, the degree of manpower and resources allocated to the project, and in compliance with the Chartered Institute of Ecology and Environmental Management's Code of Professional Conduct.

Just Mammals Limited is an ecological consultancy based in Mid-Wales. Specialising in legally protected mammal, reptile and amphibian species, but providing a wide range of ecological services, it provides appropriate expertise on behalf of a range of clients.

Clients include government departments, local and regional authorities, development agencies, commercial and industrial enterprises as well as statutory nature conservation organisations, wildlife trusts and other charitable bodies.

Please visit our web site [www.justmammals.co.uk](http://www.justmammals.co.uk) to see the full range of services we offer and some of the projects we have undertaken in the past.



## **Natural Problem Solvers**

Just Mammals Limited, Suite 131-136, Plas y Ffynnon, Cambrian Way, Brecon  
LD3 7HP Tel: 01874 623616

Oak Grove Farm  
**Portskewett**  
**Monmouthshire**  
**NP26 5UT**

A **Preliminary Ecological**  
**Appraisal By:**



  
*Just*  
**MAMMALS**  
Limited  
Ecological Consultancy

On **Behalf Of:**



January **2024**

File Reference: **JM18723**

Status	Name	Position	Date
Author	Phoebe Williams BA (Hons) MSc	Ecologist	18 <sup>th</sup> January 2024
Reviewer	Carola Hoskins BA (Hons) MSc ACIEEM	Principal Ecologist	22 <sup>nd</sup> January 2024
Valid until	12 <sup>th</sup> January 2026		

**Directors:** Carola Hoskins BA (Hons) MSc ACIEEM Robert Morgan Phoebe Williams BA (Hons) MSc  
**Registered Office:** Suite 131 -136, Plas y Ffynnon, Cambrian Way, Brecon LD3 7TG  
**Web Site:** [www.justmammals.co.uk](http://www.justmammals.co.uk) **Email:** [phoebe@justmammals.co.uk](mailto:phoebe@justmammals.co.uk) **Telephone:** 01874 623616  
**Registered In:** Wales **Registration Number:** 13099914 **VAT No:** 821 6376 35



## Contents

	<b>Page No.</b>	
<b>1</b>	<b>Executive Summary</b>	<b>1</b>
<b>2</b>	<b>Introduction</b>	<b>1</b>
<b>3</b>	<b>Survey Team Experience</b>	<b>1 – 2</b>
<b>4</b>	<b>Survey Methodology</b>	<b>2</b>
<b>5</b>	<b>Site Description</b>	<b>2</b>
<b>6</b>	<b>Desktop Study</b>	<b>2 – 3</b>
<b>7</b>	<b>Survey Constraints</b>	<b>3</b>
<b>8</b>	<b>Survey Results</b>	<b>3 – 4</b>
<b>9</b>	<b>Discussion and Conclusions</b>	<b>4 – 5</b>
<b>10</b>	<b>Recommendations</b>	<b>5 – 6</b>
<b>10</b>	<b>Bibliography</b>	<b>7</b>
	<b>Appendix I: Site Location Plan</b>	<b>8</b>
	<b>Appendix II: Site Photographs</b>	<b>9</b>
	<b>Appendix III: Phase 1 Habitat Map</b>	<b>10</b>
	<b>Appendix IV: List of Recorded Species</b>	<b>11</b>
	<b>Appendix V: Relevant Legislation</b>	<b>12</b>

### List of Tables

Table	Description of Contents	Page No.
Table 1	Summary of Survey Activity and Weather Conditions	3
Table 2	Summary of Phase 1 Habitat Notes	3 - 4
Table 3	Recommended Native Tree and Shrub Species	6
Table 4	List of Recorded Species	11

### List of Figures

Figure	Description of Contents	Page No.
Figure 1	Site location plan	8
Figure 2	Phase 1 habitat survey map	10

### List of Plates

Plate	Description of Contents	Page No.
Plate 1	Looking east across the site	9
Plate 2	Looking west across the site	9
Plate 3	Target note 1: mature oak with PRF and cavity	9
Plate 4	Looking north along eastern hedgerow boundary	9
Plate 5	Target note 2: mature oak with PRF	9
Plate 6	Looking south at the eastern end of the site	9
Plate 7	South-west boundary	9
Plate 8	Looking west across the site	9

## 1 Executive Summary

- 1.1 A suitability assessment of various sites in Monmouthshire is being carried out by Monmouthshire County Council for the possible creation of Gypsy Roma Traveller (GRT) Sites, to be included within the Replacement Local Development Plan (RLDP). A small area of land at Oak Grove Farm, Portskewett, forms part of the suitability assessment. To support the proposals, a Preliminary Ecological Appraisal of the two fields that make up the site, was conducted in January 2024, by an ecologist and an assistant.
- 1.2 The land subject to survey makes up part of Oak Grove Farm and comprises two fields, an eastern field and a western field, separated by post and wire fencing. Boundary features include trees, hedgerow and fencing. The north-western end of the western field has no obvious boundary feature, and is a continuation of the wider field that is outside the survey area. To the south of the site stretches the B4245. The surrounding landscape is typically rural and primarily characterised by pastoral farmland, a solar farm is located to the west of the site, adjacent to which stretches Ballan Wood.
- 1.3 Protected species and their potential presence on site were considered as part of the assessment. No further survey is required at the site at this time. It is recommended that all trees on site are retained and safeguarded as part of the proposals, this will help in retaining some ecological value on site. If any trees are proposed to be removed, further survey will be required, by way of assessment to determine their suitability for roosting bats.
- 1.4 Enhancements for biodiversity are required to meet the planning policy as indicated by Planning Policy Wales 11, and Future Wales, policy documents. This report makes recommendations to provide enhancements for biodiversity on site, including the installation of bird and bat boxes, as well as planting of hedgerows and woodland.

## 2 Introduction

- 2.1 Just Mammals Limited was commissioned by Monmouthshire County Council (MCC) to complete a Preliminary Ecological Appraisal of an area of land within Oak Grove Farm, Portskewett, approximately 2km north-east of Caldicot. The site subject to survey comprises two agricultural fields, centred on National Grid Reference ST 49956 90040, standing at an altitude of 46m Above Ordnance Datum.
- 2.2 MCC are currently considering the suitability of various sites in Monmouthshire for the creation of Gypsy Roma Traveller (GRT) Sites, for inclusion within the Replacement Local Development Plan (RLDP). Due to the early stage of the assessment, no design plans are available at the time of writing this report. To support the plans, Just Mammals Limited were commissioned to carry out a Preliminary Ecological Appraisal of the land within Oak Grove Farm. An initial assessment of the wider site of Oak Grove Farm was undertaken in 2020 (Just Mammals LLP 2020). Most recent survey is detailed in this report, and includes an assessment of the smaller area proposed for possible development only. This assessment was undertaken on the 12<sup>th</sup> of January 2024.
- 2.3 This report makes recommendations concerning the ecological value of the site, as well as the need for further survey work as appropriate. The different types of habitat were assessed, and the potential presence of protected species, such as badger (*Meles meles*), otter (*Lutra lutra*), dormouse (*Muscardinus avellanarius*), reptiles and amphibians, as well as bats and nesting birds were considered. Section 7 species such as hedgehog (*Erinaceus europaeus*) were also considered.

## 3 Survey Team Experience

- 3.1 Undertaking the assessment, and author of this report is Phoebe Williams. A Geography graduate from the University of Exeter, and a former trainee at Gwent Wildlife Trust she has completed a Natural Talent trainee programme, studying Hemiptera at the National Museum of Wales. Practical experience includes survey work for dormice, botany, newts, reptiles, and invertebrates. Phoebe has undertaken an MSc in Wildlife and Conservation Management at the University of South Wales. She is an ecologist with Just Mammals Limited. Phoebe holds a Great crested newt (NRW) S092295/1 (Expiry 26th February 2025), and is an accredited agent on NRW bat licence S091842/2 (expiry 10<sup>th</sup> November 2024).

- 3.2 Assisting with the survey effort was Catherine Povey. After graduating from Swansea University and University College London, Catherine worked in medical research and as a practitioner. Since the first year of her degree when she studied Zoology and Botany, she has retained a keen interest in the natural world and has worked with Bannau Brycheiniog National Park on a number of projects, including peat conservation. She is employed by Just Mammals Limited as a Trainee Ecologist and has conducted a variety of surveys with the company including dusk bat emergence surveys for commercial projects.

## 4 Survey Methodology

- 4.1 A Preliminary Ecological Appraisal (PEA) was conducted on the 12<sup>th</sup> of January 2024. Details of the survey and weather conditions are provided in Table 1. Prior to the site visit, a desktop study was undertaken, which involved a standard search area of a 2km radius from the site (using a central grid reference), using the MAGIC website. Details of statutory sites designated for nature conservation were obtained. A record search was also commissioned from South East Wales Biodiversity Records Centre (SEWBRc).
- 4.2 The assessment comprised a survey employing the Phase 1 habitat survey methodology. This is a standardised technique for classifying and mapping British habitats. All areas within the site were inspected and assessed for indicators of ecological value, including the presence and/or field signs of any protected or rare habitats and species. The site was walked over, recording all plant species and features onto a custom-made recording sheet. Habitats and notes were drawn onto a map of the survey site and photographs were taken. A coloured Phase 1 habitat map was produced (Appendix III).
- 4.3 Assessment for the presence or potential absence of other protected species, including hazel dormouse, badger, reptiles and amphibians, was undertaken by considering the features of the site. Such features include grassland and dense vegetation. The potential suitability of the site for nesting birds was also considered.

## 5 Site Description

- 5.1 Situated to the north-east of Caldicot, approximately 1.3km north of Portskewett, the site subject to survey makes up part of Oak Grove Farm. The site covers 7.5ha, and comprises two fields, an eastern field and a western field, separated by post and wire fencing. Boundary features include trees, hedgerow and fencing. The north-western end of the western field has no obvious boundary feature, and is part of a larger field that is outside of the survey area. To the south of the site runs the B4245. The surrounding landscape is typically rural and primarily characterised by pastoral farmland. A solar farm is located to the west of the site, adjacent to which stretches Ballan Wood.

## 6 Desktop Study

- 6.1 A record search was commissioned from South East Wales Biological Records Centre (SEWBRc) (unique reference 0234-679) to ascertain whether protected species have been recorded at or close to the site. The search revealed no records of priority species at the site.
- 6.2 The data set revealed protected species records within 1km of the site. The record search is summarised below:
- Mammals accounted for 72 records, species include; hedgehog (*Erinaceus europaeus*), polecat (*Mustela putorius*), and badger (*Meles meles*) all recorded over 500m from the site, field signs for dormouse (*Muscardinus avellanarius*) have been noted within Ballan Wood over 600m from the site. Bat records include noctule (*Nyctalus noctula*), brown long-eared (*Plecotus auritus*), natterer's (*Myotis nattereri*), common pipistrelle (*Pipistrellus pipistrellus*), soprano pipistrelle (*Pipistrellus pygmaeus*) all over 800m from the site, and lesser horseshoe (*Rhinolophus hipposideros*) bat has been recorded over 1.4km from the site;
  - Birds accounted for 322 records, species include kestrel (*Falco tinnunculus*) over 290m from the site, red kite (*Milvus milvus*), herring gull (*Larus argentatus*), hawfinch (*Coccothraustes coccothraustes*), lesser spotted woodpecker (*Dryobates minor*), starling (*Sturnus vulgaris*) and cormorant (*Phalacrocorax carbo*) all over 500m from the site;
  - A single reptile record was returned of grass snake (*Natrix helvetica*) over 600m from the site, no amphibian records were returned;
  - Invertebrate records include 13 records, grayling (*Hipparchia semele*) is the closest recorded over 500m from the site, over 700m from the site brown-banded carder bee (*Bombus humilis*), and shrill carder bee (*Bombus sylvarum*) have been recorded;

- Vascular plants include 135 records, species include; charlock (*Sinapis arvensis*), greater pond-sedge (*Carex riparia*), Spurge-laurel (*Daphne laureola*), and wood spurge (*Euphorbia amygdaloides*) have been recorded over 500m from the site;
  - Bryophytes includes 14 records, the closest record is of common pocket-moss (*Fissidens taxifolius*), over 900m from the site.
- 6.3 By consulting Magic Map, it was determined that no part of the site contains, or is within, any statutory sites of nature conservation interest, such as an Sites of Special Scientific Interest (SSSI), Special Areas of Concern (SAC), National Nature Reserve (NNR) or Local Nature Reserves (LNR) etc. No sites of conservation interest form part of the site. The desktop study confirmed three sites of interest within 2km of the site. These include Bush Close SSSI 1.4km south-west of the site, Dinham Meadows SSSI 1.5km to the north-west of the site, and Nedern Brook Wetlands, Caldicot SSSI 1.3km south-west of the site.
- 6.4 The record search also revealed Sites of Importance for Nature Conservation (SINC) within 1km of the area of land subject to survey. These are listed below with significance of the sites also included, where information is available:
- Ballan Wood: just over 415m to the west of the site, a combination of Ancient Semi-natural Woodland (ASNW) and a Restored Ancient Woodland Site (RAWS);
  - Sunny Bank: just under 400m to the north-west of the site;
  - Farthing Hill: over 900m to the south-west of the site.
- 6.5 The site subject to survey does not form part of any of the above designated sites. Given the scale of the development and the distance of sites of conservation interest from the site subject to assessment, it is considered unlikely that proposals will impact designated sites within the surrounding area at this time.

## 7 Survey Constraints

- 7.1 The comprehensiveness of any ecological assessment may be limited by the nature of the site visit, it being a single snapshot of the site at any point in time. This report cannot therefore be considered to provide a fully comprehensive analysis of the ecological interest of the site. However, it does provide an ecological assessment of the site for supporting habitats and species on the day of the visit and highlights areas where further survey work may be required.

## 8 Survey Results

- 8.1 Details of the conditions under which survey was conducted is given in Table 1. Wind speeds given employ the Beaufort scale.

**Table 1: Summary of Survey Activity and Weather Conditions**

Survey Type and Location	Dates	Timing	Weather Conditions
Day time visual inspection, botanical survey and habitat assessment, including protected species assessment	12/01/2024	13.30 – 14.30 hours Greenwich Mean Time	Air temperature: 5°C Cloud cover: 8/8 oktas Wind speed: F3, gentle breeze Conditions: Dry
<b>Surveyors</b>	Phoebe Williams and Catherine Povey		

- 8.2 The site was divided into seven different types of habitat for recording purposes. Table 2 below provides details of the various habitats and the dominant species for each of them.

**Table 2: Summary of Phase 1 Habitat Notes**

Habitat	Phase 1 Classification	Description of Area and Typical Species
Type 1	B4 Improved grassland	The eastern field is made up of this habitat, and comprises a low diversity of forb species. Grassland sward is short and grazed by sheep.  Species present include perennial rye grass ( <i>Lolium perenne</i> ), broad-leaved dock ( <i>Rumex obtusifolius</i> ), creeping buttercup ( <i>Ranunculus repens</i> ) and common chickweed ( <i>Stellaria media</i> ).
Type 2	B6 Semi-improved grassland	The western field is slightly less improved, with a few more forb species, although still considered to be species poor. Grassland sward is short.  Species present include perennial rye grass, Yorkshire fog ( <i>Holcus lanatus</i> ), dandelion ( <i>Taraxacum officinale</i> ), clover ( <i>Trifolium</i> sp.), meadow buttercup ( <i>Ranunculus acris</i> ) and cocks foot ( <i>Dactylis glomerata</i> ).

Type 3	A3.1 Scattered trees	A small number of trees stand at the site boundaries. Specimen are mature. Species present include pedunculate oak ( <i>Quercus robur</i> ) and hawthorn ( <i>Crataegus monogyna</i> ).  <b>Target Note 1: Pedunculate oak with potential roost feature</b> <b>Target Note 2: Pedunculate oak with potential roost feature</b> <b>Target Note 3: Hawthorn with old bird nest</b>
Type 4	J2.1.2 Intact hedgerow, species poor	This habitat stretches along the eastern field edge and to the south. There are less than five woody species along a typical 30m stretch. Generally, the hedgerow is >2m wide and >2m tall.  Hedgerow is dominated by blackthorn ( <i>Prunus spinosa</i> ) and hawthorn. Other species present include ivy ( <i>Hedera helix</i> ), cleavers ( <i>Galium aparine</i> ), elder ( <i>Sambucus nigra</i> ), and holly ( <i>Ilex aquifolium</i> ).
Type 5	J2.2.2 Defunct hedgerow	A short section of hedgerow present at the south-east end of the site is defunct.  Species include bracken ( <i>Pteridium aquilinum</i> ), bramble ( <i>Rubus fruticosus</i> ) and hawthorn.
Type 6	J2.3.2 Hedge with trees, species poor	At the southern end of the site, trees align the hedgerow. Generally, specimen are less mature, although three mature pedunculate oak trees are present.  Species include hazel ( <i>Corylus avellana</i> ), ivy, cleavers, blackthorn, and holly.
Type 7	J2.4 Fence	A post and wire fence aligns most of the site boundaries, apart from the north-western end of the site.

- 8.3 A coloured Phase 1 habitat map was produced (see Appendix III). A total of 54 species of plants were recorded during the survey, these are listed in Appendix IV.
- 8.4 Ecological assessment included identification of the potential for protected species to be present on site. Reptiles make use of open, rank habitats which provide a mixture of open areas and cover. Habitat on site comprises short sward grassland that is grazed by sheep. A single reptile record was returned from the data search, a grass snake over 600m away.
- 8.5 During the terrestrial part of their lifecycle, amphibians have similar habitat requirements to reptiles, with both species' groups favouring unmanaged, rank grassland, scrubby vegetation and variation in vegetative architecture. No amphibians were noted during the survey. No ponds are present, ruling out the possibility for them to breed on site. Since great crested newts are known to use terrestrial habitat up to 500m from their breeding ponds, the wider landscape must also be taken into consideration. Review of aerial maps show a single pond just under 300m to the south-east of the site. No other ponds are present within 500m of the site. No amphibian records were returned from the data search.
- 8.6 Bats use trees as well as buildings for roosting, where they will exploit gaps, cracks and crevices in the bark. An extensive survey of trees and their suitability for bats was not undertaken, as this is beyond the scope of the preliminary assessment. However, two trees (Target Note 1 and 2) were noted as having Potential Roost Features (PRF). Features include knot holes, and a possible internal cavity. Features were not inspected during the PEA.
- 8.7 Hazel dormice are associated with well-defined, connected hedgerows that link to further suitable habitat elsewhere in the landscape. No evidence of dormice was recorded during the survey. Hedgerows on site are isolated, with a lack of connectivity to suitable areas of habitat in the wider landscape. Evidence for the presence of dormouse has been found in Ballan Wood, around 600m to the west of the site.
- 8.8 No evidence of badger was noted during the survey, such as setts, footprints, hairs, latrines or other indicators of their presence. Badgers are highly mobile and can range great distances, favouring sloping ground in wooded areas where they can dig their setts and forage away from disturbance. No dense areas of woodland are present on site. An area of woodland is present to the south-west of the site, around 600m away. Badger has been recorded within Ballan Wood.
- 8.9 An historic bird nest was noted within a hawthorn tree to the west of the site (Target Note 3). Survey was undertaken outside of the bird nesting season, as such, no nesting activity was observed. Habitats on site, namely hedgerows and scattered trees are suitable for nesting birds.

- 8.10 Species such as otter, white-clawed crayfish (*Austropotamobius pallipes*) and water vole (*Arvicola amphibius*) are highly reliant on water bodies. No water bodies are present on, or immediately adjacent to the site. The site is not considered suitable for either of these species.

## 9 Discussion and Conclusions

- 9.1 An area of land that makes up part of Oak Grove Farm is being considered to be developed as a GRT Site. Suitability surveys are currently being undertaken, consequently no design plans are available at the time of writing this report. The land subject to survey currently comprises improved and semi-improved, species poor grassland. Boundary features include species poor hedgerow, and few scattered trees. Overall, the site subject to survey is assessed as having a low level of ecological value, although boundary features and trees increase the value of the site.
- 9.2 Habitat on site is not considered suitable for reptiles or amphibians, given the lack of shelter provided by the short sward, grazed grassland. No amphibian records were returned from the data search. A single reptile record was returned from the data search, a grass snake over 600m away. There is a pond present 300m to the south-east, however this is not well connected to the site due to the presence of surrounding open, agricultural fields and lack of connecting features. Furthermore, the absence of suitable habitat to provide shelter makes the site unsuitable for amphibians.
- 9.3 Detailed assessment of the trees on site was not undertaken. Two trees were noted during the survey as having features that may be suitable for roosting bats, although depth and suitability of features were not thoroughly inspected. If any trees are earmarked for removal, further assessment for bats is required.
- 9.4 Evidence to suggest the presence of dormice has been recorded over 600m from the site. There are hedgerows present on site, however, these are isolated and not well connected to areas of suitable habitat within the wider landscape, including Ballan Wood. It is therefore considered unlikely that dormice are using the site at this time. Recommendations below include planting or new hedgerow to give better connectivity to and from Ballan Wood.
- 9.5 No live or dead badgers were recorded during the survey, and no features of interest are present on site for this species. Badger presence has been noted within Ballan Wood to the west. Therefore, occasional passage through the site by badgers cannot entirely be discounted. Appropriate precautionary measures must be taken during construction to ensure mammals are protected during construction works.
- 9.6 Habitat such as trees and hedgerow provides suitable habitat for birds to nest. All nesting birds, their chicks, eggs and nests whilst in use are protected under the Wildlife and Countryside Act 1981 (as amended). Recommendations for best practices regarding nesting birds are made below.

## 10 Recommendations

- 10.1 No further survey is required at the site at this time. It is highly recommended that all trees on site are retained and safeguarded as part of the proposals, this will help in retaining some ecological value on site. If any trees are proposed to be removed, further survey will be required, by way of assessment to determine their suitability for roosting bats.
- 10.2 It is recommended that the hedgerow is also retained and protected as part of the proposals. Recommendations below include enhancing the existing hedgerow on site, as well as re-instating the defunct hedgerow through planting. If any vegetation is to be cut down, it must be removed outside of the bird nesting season, which runs between March and August, inclusive. If, whilst the vegetation is being removed an active nest is discovered, all works within a 2m radius of the nest must be immediately stopped, and not recommenced until all chicks have fledged.
- 10.3 To protect any mammals that may pass through the site, any trenches dug forming part of the groundworks must be covered overnight, or left with a 45° sloping side to prevent any animal from becoming trapped. Similarly, any unconnected pipes must be capped overnight to prevent any animal from becoming stuck.
- 10.4 Potential presence of nocturnal animals, such as foraging bats on site requires considerate design of a sensitive lighting scheme. Any new lighting columns must not exceed 4m in height, and must be affixed with cowls, hoods or shrouds to minimise upward light spill. Luminosity will be limited to the absolute minimum required by Health and Safety standards, and will ideally be timed to be

extinguished for as long a period as possible during the night. All lights must face downwards and must not point directly at any natural features. This is also important for any temporary lighting installed for use during construction. Any external lighting affixed to the exterior of the proposed houses must be motion-activated and pointed in a downward facing direction, away from natural features. Any new lighting installed must adhere to the ILP (2023) guidelines for artificial lighting.

- 10.5 Works provide the opportunity to enhance the biodiversity of the site, and to comply with Planning Policy Wales 11 (PPW11). An area of the site must be set aside as an enhancement for wildlife. This area would benefit from the creation of a small pond, the margins of which must be left to grow, in addition to woodland and hedgerow planting. Hedgerow planting is recommended around the field margins to create new hedgerow features, and to re-instate the defunct hedgerow. Table 3 below includes a list of suitable native tree and hedgerow species, which can be planted as part of the proposals. Species used must be native, with a mix of at least five different species. It is essential that such plants are sourced locally in order to reduce likelihood of importing diseases. It is recommended that a strip of vegetation alongside the hedgerows is left to grow rank (at least 1m wide), this will provide additional shelter and add to the mix of habitats to be created at the site.

**Table 3: Recommended Native Tree and Shrub Species**

Common Name	Scientific Name
Beech	<i>Fagus sylvatica</i>
Blackthorn	<i>Prunus spinosa</i>
Crab apple	<i>Malus sylvestris</i>
Dogwood	<i>Cornus sanguinea</i>
Downy birch	<i>Betula pubescens</i>
Elder	<i>Sambucus nigra</i>
Field maple	<i>Acer campestre</i>
Common hawthorn	<i>Crataegus monogyna</i>
Hazel	<i>Corylus avellana</i>
Holly	<i>Ilex aquifolium</i>
Pedunculate oak	<i>Quercus robur</i>
Sessile oak	<i>Quercus petraea</i>
Silver birch	<i>Betula pendula</i>
Spindle	<i>Euonymus europaeus</i>

- 10.6 Bird boxes and bat boxes are an effective way of attracting species to the site. At least four woodcrete/woodstone bird boxes are recommended to be installed at the site. Bird boxes are proposed to be of different designs, including; Vivara Pro Serville 32mm Woodstone nest boxes, and Vivara Pro Barcelona Woodstone Open nest boxes (or similar). Bird boxes must be approximately 3m above the ground, with a clear flight path. Boxes must be sheltered from prevailing wind, rain and strong sunlight. Boxes must not be positioned too close together, and can be attached to the trees on site.
- 10.7 With regard to enhancement bat boxes, it is recommended to install two bat boxes (Schwegler 2F bat boxes, or similar), on trees within the site. These are to be installed close to natural linear features such as a trees, and away from any artificial light source. Boxes must be at least 4m above the ground and sheltered from strong winds (usually south, south-east or south-west elevations).
- 10.8 It is important to implement good horticultural practice in any landscaping scheme, including the use of peat-free composts, mulches and soil conditioners. The use of pesticides (i.e. herbicides, insecticides, fungicides and slug pellets etc) must be discouraged to prevent cumulative fatal effects to animals via the food chain, particularly invertebrates, birds and/or mammals. Any pesticides used must be non-residual.
- 10.9 Any fencing must have a continuous gap of approximately 15cm beneath it, to ensure wildlife can continue to move across the site.

## 11 Bibliography

Anon. (2023). 'Bats and Artificial Lighting in the UK: Guidance Note 08/23'. The Institution of Lighting Professionals and Bat Conservation Trust, Rugby

Joint Nature Conservation Committee (1993). '*Handbook for Phase 1 Habitat Survey – A Technique for Environmental Audit*'. JNCC, Peterborough

Mitchell-Jones A.J. and McLeish A.P. (2004). '*The Bat Workers Manual, 3<sup>rd</sup> Edition*', English Nature, Peterborough

Rose, F. (1981). '*The Wild Flower Key*'. Frederick Warne, London

Streeter, D. (2009). '*Collins Flower Guide*'. Harper Collins, London



## Appendix I: Site Location Plan

Figure 1: Site location plan



## Appendix II: Site Photographs

Plate 1: Looking east across the site



Plate 2: Looking west across the site



Plate 3: Target note 1: mature oak with PRF and cavity



Plate 4: Looking north along eastern hedgerow boundary



Plate 5: Target note 2: mature oak with PRF



Plate 6: Looking south at the eastern end of the site



Plate 7: South-west boundary

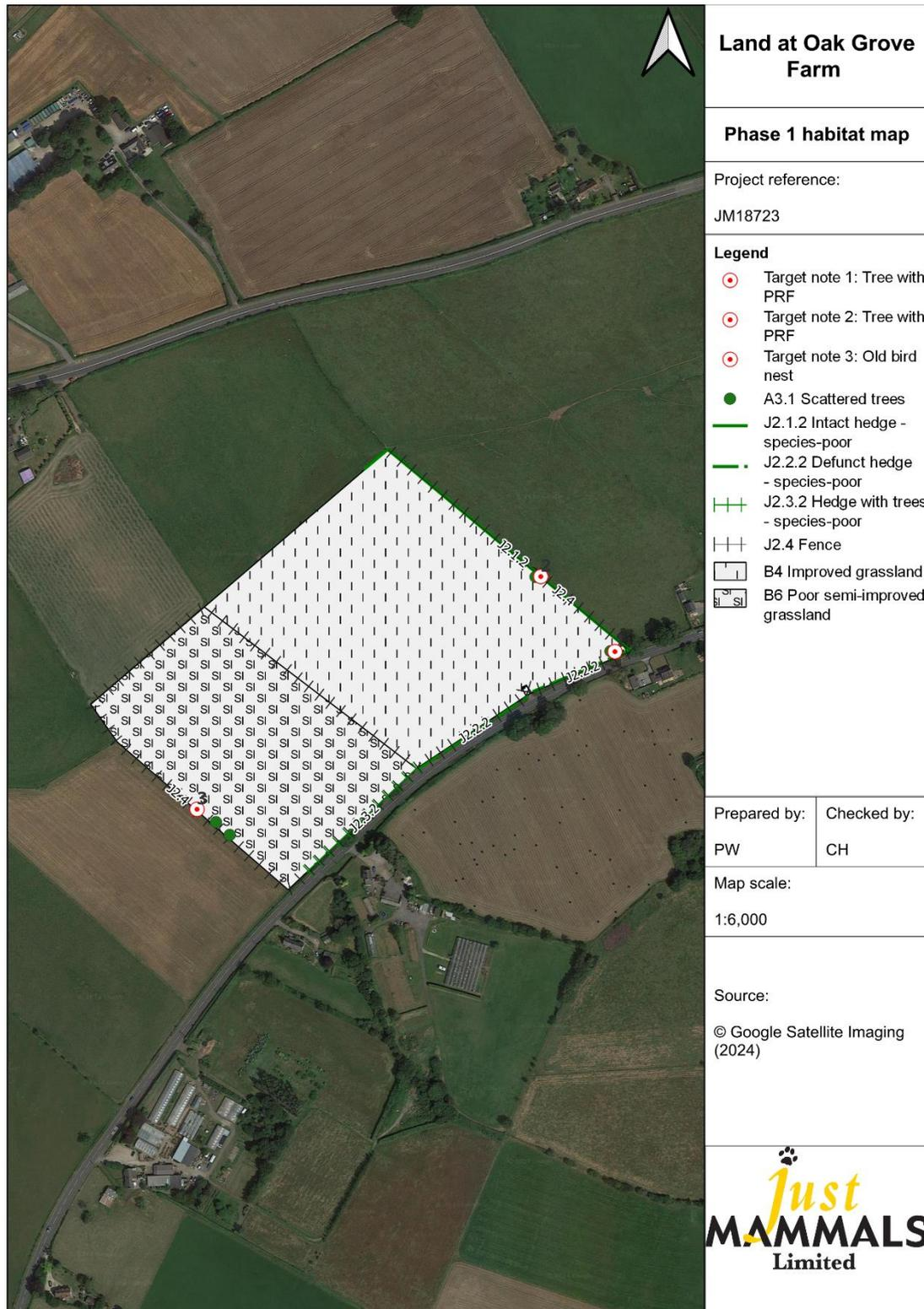

Plate 8: Looking west across the site



### Appendix III: Phase 1 Habitat Map

Figure 2: Phase 1 habitat survey map



## Appendix IV: List of Recorded Species

**Table 3: List of Recorded Species**

Plant Species		JNCC Broad Habitat Types					
Common Name	Scientific Name	B4	B6	A3.1	J2.1.2	J2.2.2	J2.3.2
Ash	<i>Fraxinus excelsior</i>				x		
Blackthorn	<i>Prunus spinosa</i>				x	x	x
Bracken	<i>Pteridium aquilinum</i>				x	x	
Bramble	<i>Rubus fruticosus</i>				x	x	x
Buttercup, Creeping	<i>Ranunculus repens</i>	x	x				
Buttercup, Meadow	<i>Ranunculus acris</i>	x					
Chickweed, Common	<i>Stellaria media</i>	x	x				
Cleavers	<i>Gallium aparine</i>				x		
Clover, A	<i>Trifolium sp</i>	x					
Cocks foot	<i>Dactylis glomerata</i>	x	x				
Dandelion	<i>Taraxacum officinale</i>	x					
Dock, Broad-leaved	<i>Rumex obtusifolius</i>	x	x				
Elder	<i>Sambucus nigra</i>				x		
Geranium, A	<i>Geranium sp</i>	x					
Ground ivy	<i>Glechoma hederacea</i>				x		
Groundsel	<i>Senecio vulgaris</i>		x				
Hawthorn	<i>Crataegus monogyna</i>			x	x	x	x
Hazel	<i>Corylus avellana</i>						x
Holly	<i>Ilex aquifolium</i>				x		x
Ivy	<i>Hedera helix</i>				x	x	x
Meadow grass, Annual	<i>Poa annua</i>	x	x				
Oak, Pedunculate	<i>Quercus robur</i>			x			x
Oxe tongue, Bristly	<i>Helminthotheca echioides</i>		x				
Plantain, Ribwort	<i>Plantago lanceolata</i>	x	x				
Rose, A	<i>Rosa sp</i>				x		
Rye grass, Perennial	<i>Lolium perenne</i>	x	x				
Yorkshire fog	<i>Holcus lanatus</i>	x					

## Appendix V: Relevant Legislation

### Wild birds

All wild birds, their eggs and nests are protected by The Wildlife and Countryside Act 1981 (as amended). It is an offence, with certain exceptions, to:

- intentionally kill, injure or take any wild bird;
- intentionally take, damage or destroy the nest of any wild bird while it is in use or being built;
- intentionally take or destroy the egg of any wild bird;
- sell wild birds or put them on display for sale;
- use traps or similar items to kill, injure or take wild birds; and
- intentionally, or recklessly disturb any wild bird listed on Schedule 1 while it is nest building, or at a nest containing eggs or young, or disturb the dependent young of such a bird.

Penalties that can be imposed for criminal offences in respect of a single bird, nest or egg contrary to the Wildlife and Countryside Act 1981 (as amended) is an unlimited fine, up to six months imprisonment or both. In exceptional cases NRW and Natural England issues licences for specific purposes, so that legitimate work may be undertaken without breaking the law.

This document has been produced by Just Mammals Limited for Monmouthshire County Council. It may not be used by any person for any other purpose other than that specified without the express written permission of Just Mammals Limited. Any liability arising out of use by a third party of this document, for purposes not wholly connected with the above, shall be the responsibility of that party, who shall indemnify Just Mammals Limited against all claims, costs, damages, and losses, arising out of such use.

Unless specifically assigned or transferred within the terms of agreement, the consultant asserts and retains all Copyright, and other Intellectual Property Rights, in and over the document and its contents.

We confirm that in preparing this document we have exercised reasonable skill and care, taking into account the project objectives, the agreed scope of the work, prevailing site conditions, the degree of manpower and resources allocated to the project, and in compliance with the Chartered Institute of Ecology and Environmental Management's Code of Professional Conduct.

Just Mammals Limited is an ecological consultancy based in Mid-Wales. Specialising in legally protected mammal, reptile and amphibian species, but providing a wide range of ecological services, it provides appropriate expertise on behalf of a range of clients.

Clients include government departments, local and regional authorities, development agencies, commercial and industrial enterprises as well as statutory nature conservation organisations, wildlife trusts and other charitable bodies.

Please visit our web site [www.justmammals.co.uk](http://www.justmammals.co.uk) to see the full range of services we offer and some of the projects we have undertaken in the past.



## **Natural Problem Solvers**

Just Mammals Limited, Suite 131-136, Plas y Ffynnon, Cambrian Way, Brecon  
LD3 7HP Tel: 01874 623616

This page is intentionally left blank



---

Project:	<b>Monmouthshire County Council Sites</b>	Job No: <b>60720932</b>
Subject:	<b>Land To Rear Of Langley Close, Magor</b>	
Prepared by:	<b>Ben Burton (Senior Consultant)</b>	Date: <b>15/05/2024</b>
Checked by:	<b>Spiro Panagi (Associate Director)</b>	Date: <b>16/05/2024</b>
Approved by:	<b>Spiro Panagi (Associate Director)</b>	Date: <b>16/05/2024</b>

---

## Appendices:

### Appendix A Site Access Considerations

#### 1. Introduction

This Technical Note (TN) has been prepared by AECOM to support the investigation into three sites for a potential Traveller settlement land use. The transport planning inputs will inform the assessment of the sites in the consideration for inclusion with the forthcoming Monmouthshire County Council (MCC) Replacement Local Development Plan (RLDP).

The three sites which have been identified for consideration are 'Land to rear of Langley Close, Magor', 'Land at Oak Grove Farm, Portskewett' and 'Land at Bradbury Farm, Crick'. It is understood that the scale of development for any potential site would be around 11 dwellings, to be comprised of temporary structures, potentially in the form of prefabricated units.

This TN discusses the transport considerations associated with 'Land to the Rear of Langley Close, Magor' and includes the following:

- Consideration of local Planning Policy and this specific land use requirement;
- Baseline reporting on existing transport infrastructure for all modes;
- Forecasts of trip generation based on local knowledge, client forecasts and industry standard software TRICS;
- Description of development proposals and review against the Council parking and design standards; and
- Consideration of the proposed access and how that could appropriately continue to serve the proposed site.

#### 2. Planning Policy Context

The Monmouthshire County Council Local Development Plan (LDP) 2011-2021 was adopted on 27 February 2014, replacing the Monmouthshire Unitary Development Plan (UDP), to become the adopted development plan for the County.

Policy H8 '*Gypsy, Traveller and Travelling Showpeople Sites*' provides the framework for assessing proposals for Traveller sites, whether for permanent, transit or emergency use. Proposals for Traveller sites are assessed against the following criteria, whereby sites:

- *"Would enable the established need to be met at a location that is accessible to schools, shops and health care, by public transport, on foot or by cycle;*
- *Have a safe and convenient access to the highway network and will not cause traffic congestion or safety problems;*

- *Are of a suitable size to allow for the planned number of caravans, amenity blocks, a play area (for children on sites housing multiple families), the access road and include sufficient space for the parking and safe circulation of all vehicles associated with occupiers within the site curtilage;*
- *Do not occupy a prominent location and are consistent with LDP policies for protecting and enhancing character and distinctiveness of the landscape and environment. Where necessary the proposal will include mitigating measures to reduce the impact, and assimilate the proposal into its surroundings e.g. screening and landscaping;*
- *Avoid areas at high risk of flooding and proximity to uses with potential sources of pollution or emissions;*
- *Are of an appropriate scale to their location and do not have an unacceptable impact on the amenities of neighbouring land uses;*
- *Are served, or can be served, by adequate on-site services for water supply, power, drainage, sewage disposal and waste disposal (storage and collection), and for Travelling Showpeople that there is a level area for outdoor storage and maintenance of equipment.”*

In terms of transport and highways, the material considerations include accessibility to local facilities and communities, safe and convenient access to the highway network and an acceptable level of traffic impact, and the ability for vehicles to be safely accommodated by internal access routes and parking facilities.

### **3. Baseline Transport Conditions**

#### Local Highway Network

Access to the proposed site at Langley Close would be provided via St Bride's Road, a single carriageway route that crosses underneath the M4 and meets the A48 approximately 3.2km to the north of the site. South of the proposed site, Langley Close connects to the B4245 via a priority T-Junction.. In the vicinity of the proposed site access, St Bride's Road has an average carriageway width between 5.0-6.0m and is subject to a 20mph speed limit to the south of the site. Approximately 40m to the north of the proposed site access, there is a speed limit increase to 60mph, reflecting the change in road characteristic to a rural route.

Langley Close is a cul-de-sac located directly to the south of the proposed site, which serves approximately 15 properties and connects to St Bride's Road via a priority T-Junction. Netherwent View is a cul-de-sac that forms a junction with the B4245 approximately 30m to the south of Langley Close.

The B4245 is the primary highway that runs in a horizontal alignment through the village of Magor and is located approximately 300m to the south of the proposed site. The B4245 is subject to a 20mph speed limit in the vicinity of the villages of Magor and Undy. The B4245 provides access to Junction 23A of the M4, via the A4810. The A4810 lies approximately 450m to the west of the proposed site and provides a strategic connection between the east of Newport and the M4.

#### Walking and Cycling Environment

To the south of the proposed site access, St Bride's Road has a footway provision on at least one side of the carriageway and footways are of minimum 2.0m width. To the north of the site and the M4 overbridge, there is little to no active travel provision on St Bride's Road. To the south of St Bride's Road, the B4245 has footways on both sides of the carriageway and includes regular crossing points in the form of pedestrian refuge islands and tactile paving / dropped kerbs. A signalised pedestrian crossing is provided adjacent to the priority junction between St Bride's Road and the B4245.

There are no existing designated active travel routes located within close proximity of the proposed site. A set of Integrated Network Maps was submitted by MCC to the Welsh Government, which set out the Council's plans for improving active travel over the following 15 years. The maps indicate a future walking

and cycling route (ref. MCC-S17C) is proposed along St Bride's Road, between the B4245 and the motorway services located at Junction 23A of the M4. Another future walking and cycling route (ref. MCC-S17A) is proposed along the length of the B4245, to the south of St Bride's Road.

Monmouthshire's Public Rights of Way (PRoW) mapping has been consulted to determine whether any existing routes pass through, or close by, to the site. Footpath ref. 372/87/3 lies close to the proposed site on Netherwent View and connects to a number of routes that cross beneath the M4, adjacent to the Mill Reen watercourse.

National Cycle Network (NCN) Route 4 is available approximately 1.6km to the southeast of the site at the village of Undy. NCN Route 4 provides a long-distance route between Newport and Chepstow, as well as to destinations located further-afield.

### Public Transport Accessibility

The IHT's *Guidance for Providing for Public Transport in Developments*, published in 1999, suggests 400m as the 'acceptable' walking distance to a bus stop. The nearest bus stops to the proposed site are located adjacent on the B4245, opposite Queens Gardens, approximately 220m from the proposed site access. Walking access to these stops is achievable via St Bride's Road and a pedestrian connection that provides a cut-through to prevent the need to continue down the length of St Bride's Road to the B4245. **Table 3-1** provides a summary of the key bus services which are available from the bus stops on the B4245. Times and frequencies listed are reflective of the latest available timetable.

**Table 3-1: Summary of Local Bus Services**

Service	Route	Days	First Service	Last Service	Approximate Frequency
74 / X74	Newport – Chepstow	Mon-Fri	07:14	19:44	Hourly
		Saturday	08:14	19:24	Hourly
	Chepstow - Newport	Mon-Fri	07:31	18:55	Hourly
		Saturday	08:35	19:40	Hourly

*Source: Bustimes.org (May 2024)*

In summary, **Table 2-1** demonstrates there is a reasonable availability of local bus services close to the site on the B4245, to which good pedestrian access is provided from the proposed site.

The nearest station to the site is Severn Tunnel Junction, which lies approximately 3.8km to the east, in Rogiet. The majority of services available at this station operate between Cardiff and a range of destinations in South West England, such as Taunton, Exeter and Penzance. On average, there are approximately four stopping services per hour. Ticket machines are available at Severn Tunnel Junction, as well as a 114-space station car park and 10 cycle stands.

### Local Facilities

The proposed site at Langley Close is positioned in close proximity to a number of accessible facilities located in the villages of Magor and Undy. These include food convenience stores, schools, community facilities, doctors, pubs / restaurants and sports / leisure facilities. The B4245 provides a continuous active travel provision through both Magor and Undy, ensuring safe access is achievable for prospective residents of the development site.

Highway Safety

Personal Injury Collision (PIC) data has been assessed using CrashMap for the most recently available 5-year period (2018-2022) in order to assess the road safety along the network in the vicinity of the site. There have been no PICs recorded on St Bride’s Road, from which access to the site is proposed. To the south of St Bride’s Road on the B4245, there have been four PICs recorded within the area of Magor, including three ‘serious’ PICs. The quantity and locations of the recorded incidents do not suggest there to be an existing highways safety issue, or incident hotspot, that could be exacerbated by the development.

**4. Potential Trip Generation & Parking Requirement**

It is understood that the scale of development for the site would be around 11 dwellings, to be comprised of temporary structures, potentially in the form of prefabricated units. The Trip Rate Information Computer System (TRICS) database has been used to calculate the proposed trip rate and subsequent trip generation for the proposed development. There are a limited number of Traveller sites available within TRICS, and as such, trip rates have been established using privately owned residential houses, with location types filtered to best represent the characteristics of the site at Langley Close. This is considered to represent a worst case scenario in terms of vehicular trip generation. The trip rates and resultant trip generation in terms of vehicle trips, for the traditional peak hours, are presented in **Table 4-1**.

**Table 4-1: Vehicle Trip Generation – Proposed Development (11 Dwellings)**

Time Period	Trip Rate			Trip Generation		
	Arrivals	Departures	Two-Way	Arrivals	Departures	Two-Way
AM Peak (08.00 – 09.00)	0.118	0.401	0.519	2	5	7
PM Peak (17.00 – 18.00)	0.368	0.153	0.521	5	2	7
Daily (07:00 – 19:00)	2.277	2.366	4.643	26	27	53

Based on the TRICS database, it is anticipated that the proposed development could generate up to seven two-way vehicles trips during the weekday AM and PM peak hours. There could be up to 53 two-way vehicle trips generated over the course of a day (07:00-19:00). In summary, the anticipated trip generation for the proposed development is low and is unlikely to have a material impact on the highway network.

MCC’s Adopted Parking Standards Supplementary Planning Guidance (SPG) sets out the required parking levels for a range of development types. The SPG sets out four different parking zones within which to classify a specific site; this site is considered to be within ‘Zone 2 – Urban’. The SPG does not contain specific standards relating to Traveller sites, therefore the following requirements in relation to residential housing are considered to be the most comparable to the development at this stage:

**Table 4-2: Adopted Parking Standards – Residential**

Type	Residents	Visitors
Houses	1 space per bedroom (maximum requirement 3 spaces)	1 space per 5 units

At this stage, the proposed number of bedrooms per unit is unknown and therefore, exact parking requirements for the site would need to be defined once the development design has been sufficiently progressed. Based on the standards above, there would be a requirement for two visitor parking spaces on site. Car parking spaces will need to be designed in accordance with the specifications set out in the SPG. As an indication, this includes the requirement to provide standard parking space dimensions of 4.8m x 2.6m.

## **5. Site Access Appraisal**

The below discussion appraises the proposed access points into the site and should be read in conjunction with the plans provided within **Appendix A**.

A preliminary junction design has been shown at the approximate location of an existing gated field access, adjacent to the existing hardstanding / parking area connecting to St Bride's Road . At this stage, the junction has been designed with a 6m kerb radii and 5.5m access road carriageway width. An indicative 2m footway has been shown on the southern side of the access junction, to tie into the surrounding footway network on the western side of St Bride's Road.

The site has an existing field access that is currently spilling mud onto the highway (viewed following wet weather), this should be prevented as it could interfere with safe carriageway operation and may need attention.

The field gate access is located alongside a turning head. Whilst this may have provided useful in design in the past, it would be an irregular layout should a more formal site access be constructed for the site. The plans included within **Appendix A** show a direct footway connection and a regularisation of the carriageway area. It should be considered that the redundant turning head area may require removal / reinstatement.

Existing levels of visibility have been assessed at the proposed access location. The visibility drawing has been shown to reflect the existing 20mph speed limit to the south of the access location, equating to a 25m visibility splay requirement, in accordance with Manual for Streets (MfS) guidance. To the north, the street setting noticeably changes to a rural route and a 160m visibility splay has been shown in accordance with DMRB requirements for a 60mph road. The change in speed limit from 20 mph to 60 mph happens in the vicinity of the site frontage and a short distance to the north of the proposed access. The indicative location of the speed limit signage change (to national speed limit) has been shown within **Appendix A**.

**Photos 5-1** and **5-2** have been included below to show the extents of visibility looking left and right at the location of the proposed access junction. The mapping used, as well as the site photos indicate a significant amount of clearance would likely be required to achieve any level of acceptable visibility looking left out of the access junction, particularly if no speed limit changes were implemented.

**Photo 5-1: Proposed Access Junction – Visibility (Looking Left)**



**Photo 5-2: Proposed Access Junction – Visibility (Looking Right)**



An alternative visibility option drawing shows a potential scenario where the 20mph speed limit is extended to allow for 25m splays in each direction. If a speed limit change were to be implemented as shown on the second visibility drawing, there would still be a requirement for significant vegetation clearance to the north of the access junction, however, this would be limited to a length of approximately 18m and would not require any clearance works in the vicinity of the M4 overbridge to the north. This may also result in a potential benefit to pedestrian safety on this section of St Bride's Road. In terms of considering the local constraints it may not be helpful or safe to just extend the 20mph to the bridge face closest to the site. **Appendix A** shows a suggested speed limit change some 110m to the north, which would alert drivers to the speed change on the other side of the M4 overbridge. This would help slow speeds through the M4 under pass and ensure speeds were suitably slow arriving into the site area.

In order to meet the requirements of a street, the carriageway in this area may require additional treatment, such as public lighting across the site frontage. It may also be the case that footways are required to be extended on both sides of the road, including to the north beyond the proposed access. The drawings contained within **Appendix A** currently show footway provision simplistically and linking southwards; this may be a point of discussion with the Highway Authority.

Swept Path Analysis (SPA) has been conducted of the site access layout. This has been assessed with a large car (5.0m length), delivery vehicle (8.0m length) and a large refuse vehicle (11.3m length). These represent the typical daily movements and the servicing needs for the site. No material issues have been identified with regards to access / egress of these vehicles. The use of the access by larger vehicles would require the full width of the access road (see refuse vehicle swept paths as an example), this is generally considered acceptable in street settings. There is sufficient frontage and visibility to widen the site access if needed and therefore this is considered to be a matter for discussion and clarification rather than a high risk issue. Should it be determined that a larger or more irregular vehicle could be required to deliver prefabricated units or static units, we can work with the team to assess the access for this.

## **6. Conclusions and Recommendations**

Overall, the setting for residential would seem an appropriate extension of a residential area and would allow travel by modes other than by car with an established network of footways and footpaths providing access to existing local facilities in Magor and Undy. However, there are clear constraints to access with regard to vehicular visibility splays to the north, looking left on exit. This would require a local change to the speed limit, which is consistent with appropriate design for street settings. There will be additional costs associated with the treatment of the existing turning head located adjacent to the proposed access, as well as for street lighting and speed limit signage. There is also some risk that additional footway extent, beyond what is shown on the plans provided, may be required to allow for movements around the junction and to accommodate street lighting and other signage.

Appendix A



### Preliminary Access Junction Design

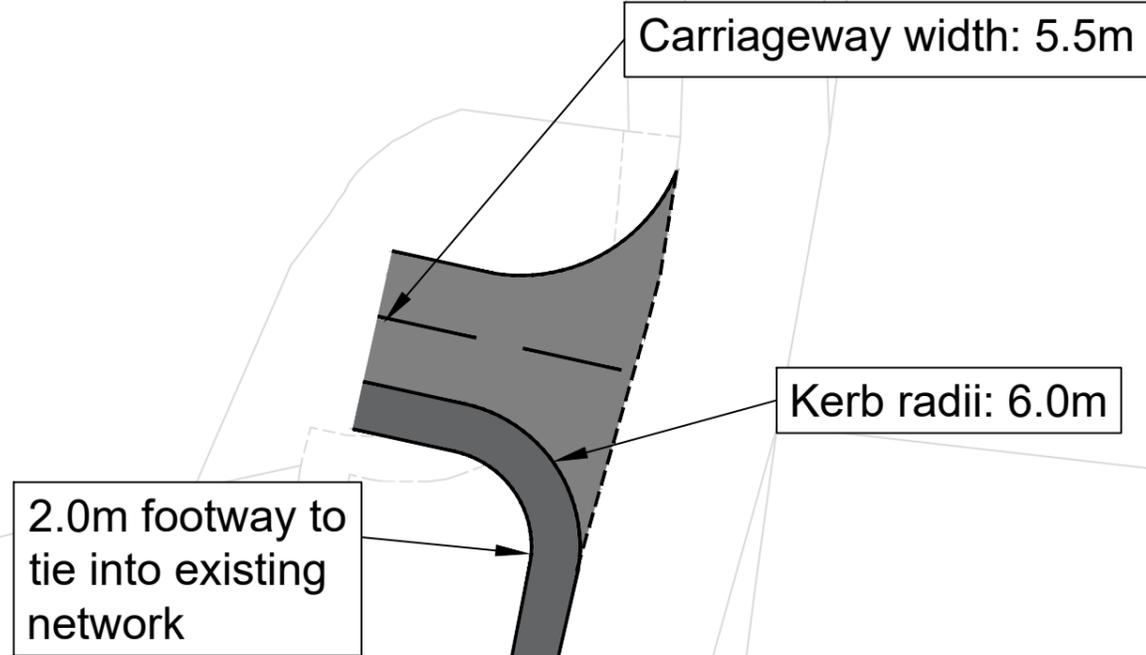

### Preliminary Access Junction Visibility Splays - 60mph

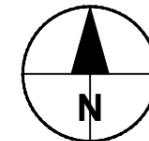

Objects / vegetation within the visibility splay limited to a maximum height of 0.6m. Significant vegetation / hedgerow clearance would be required to achieve 160m visibility splay in this direction.

Visibility (looking left)



Visibility (looking right)



Indicative location of existing speed limit signage, representing a change in speed limit between 60mph (to the north) and 20mph (to the south).

+ 12.5m

**Key:**

- 2.4m x 160m Visibility Splay (DMRB Guidance for 60mph)
- Area to be kept clear of obstructions
- 2.4m x 25m Visibility Splay (MfS Guidance for 20mph)
- Area to be kept clear of obstructions

### Preliminary Access Junction Design

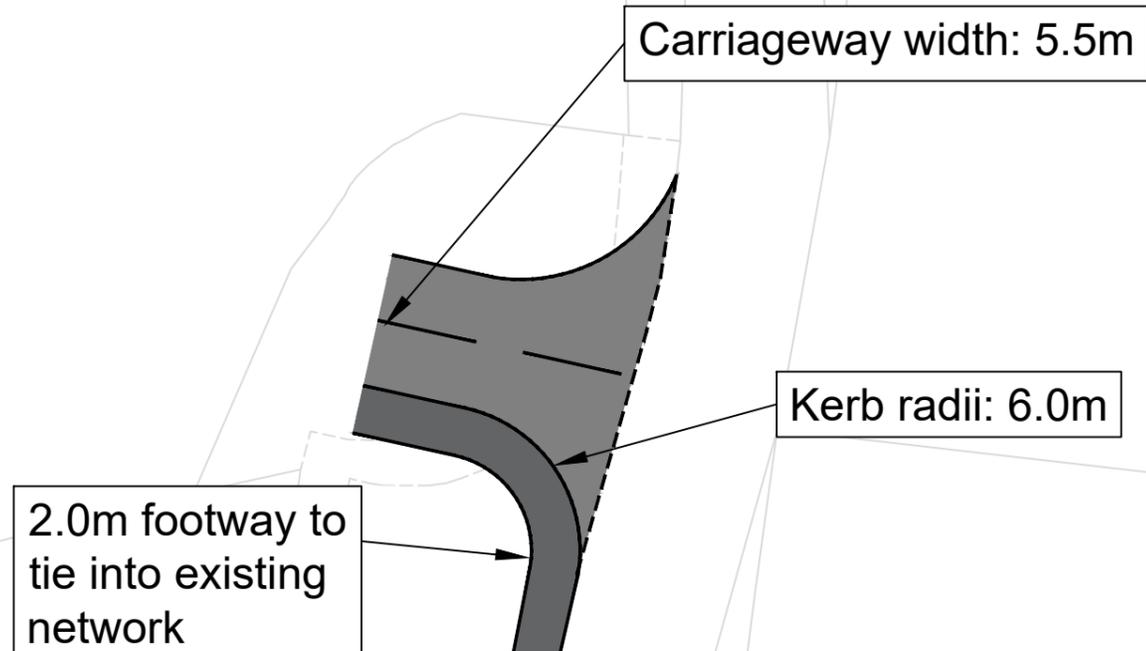

### Preliminary Access Junction Visibility Splays - 20mph

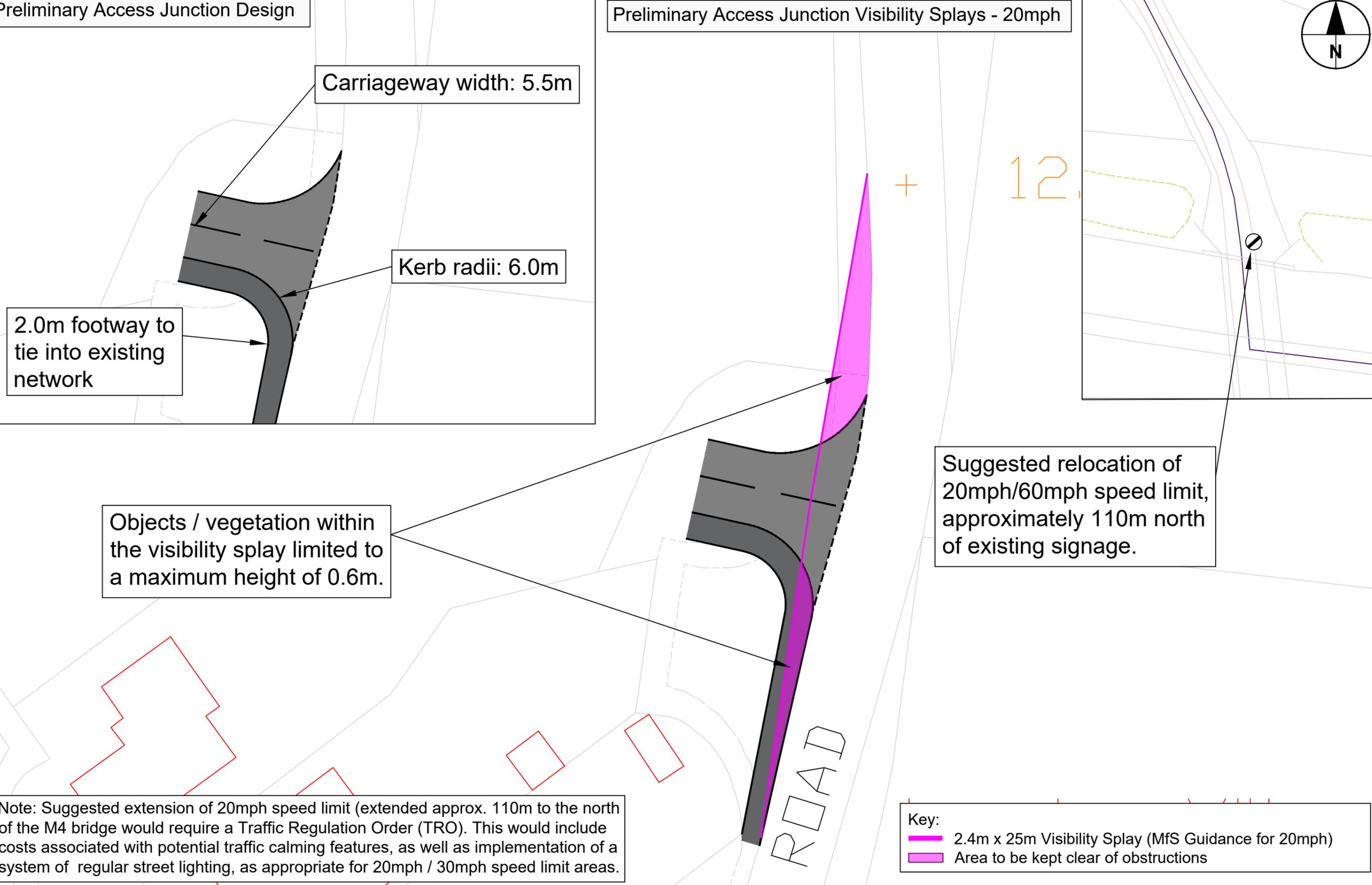

Note: Suggested extension of 20mph speed limit (extended approx. 110m to the north of the M4 bridge) would require a Traffic Regulation Order (TRO). This would include costs associated with potential traffic calming features, as well as implementation of a system of regular street lighting, as appropriate for 20mph / 30mph speed limit areas.

Large Car - Left-turn in

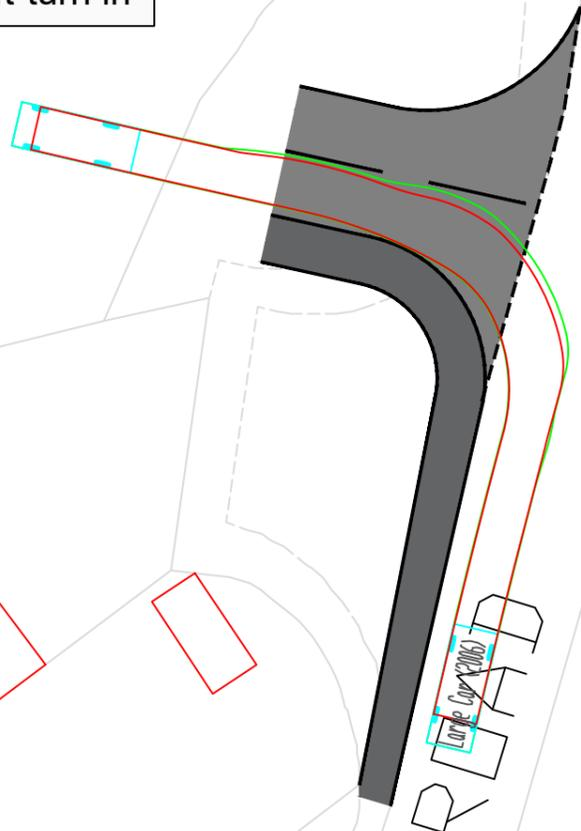

Langley

Large Car - Left-turn out

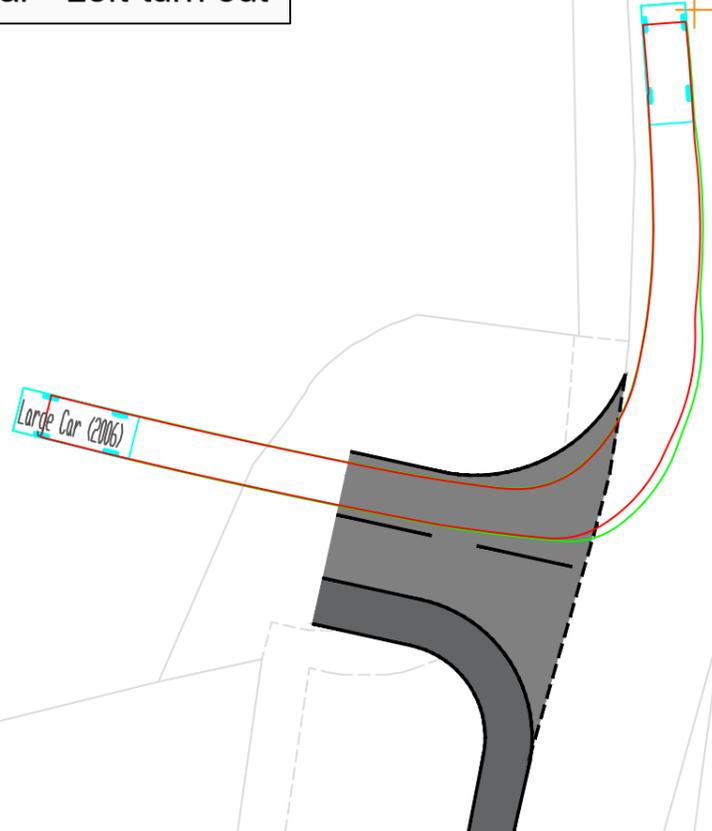

12.5



Large Car - Right-turn in

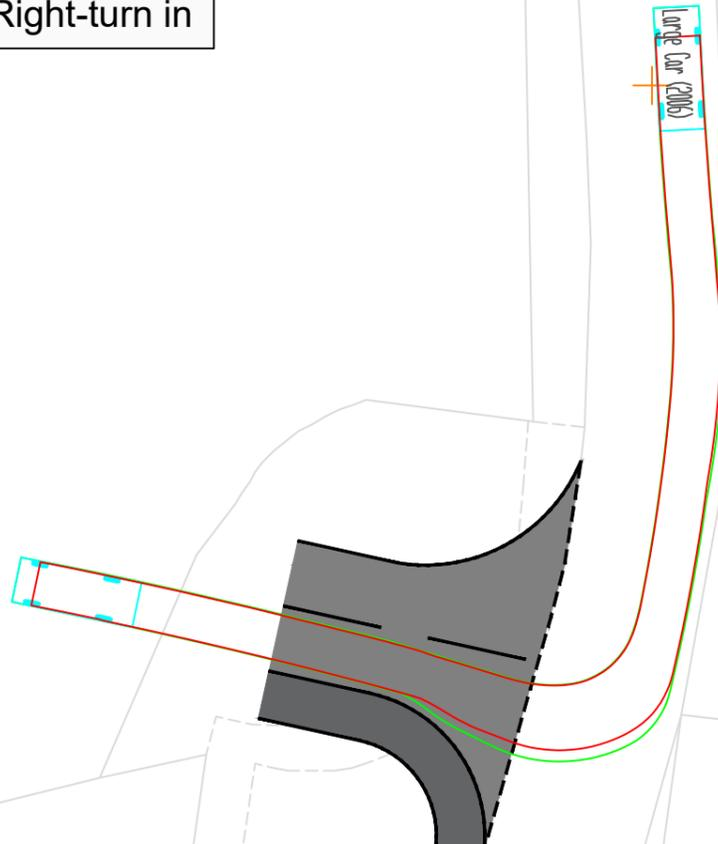

12.5m

Large Car - Right-turn out

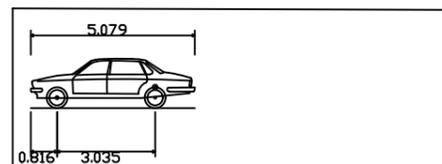
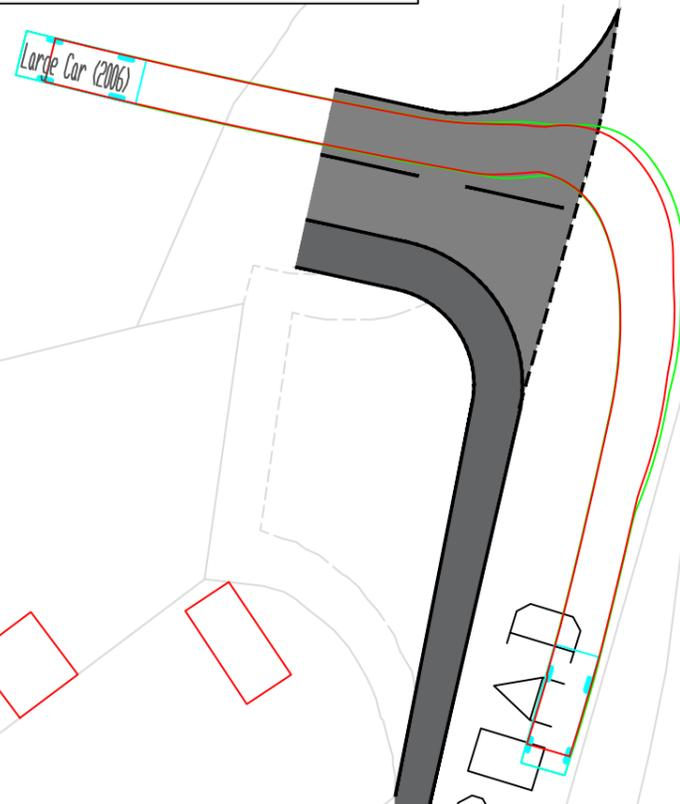

Large Car (2006)	
Overall Length	5.079m
Overall Width	1.872m
Overall Body Height	1.525m
Min Body Ground Clearance	0.310m
Max Track Width	1.831m
Lock to lock time	4.00s
Kerb to Kerb Turning Radius	5.900m

# Land to rear of Langley Close, Magor

Monmouthshire County Council Sites  
Site Access Considerations



Delivery Van - Left-turn in

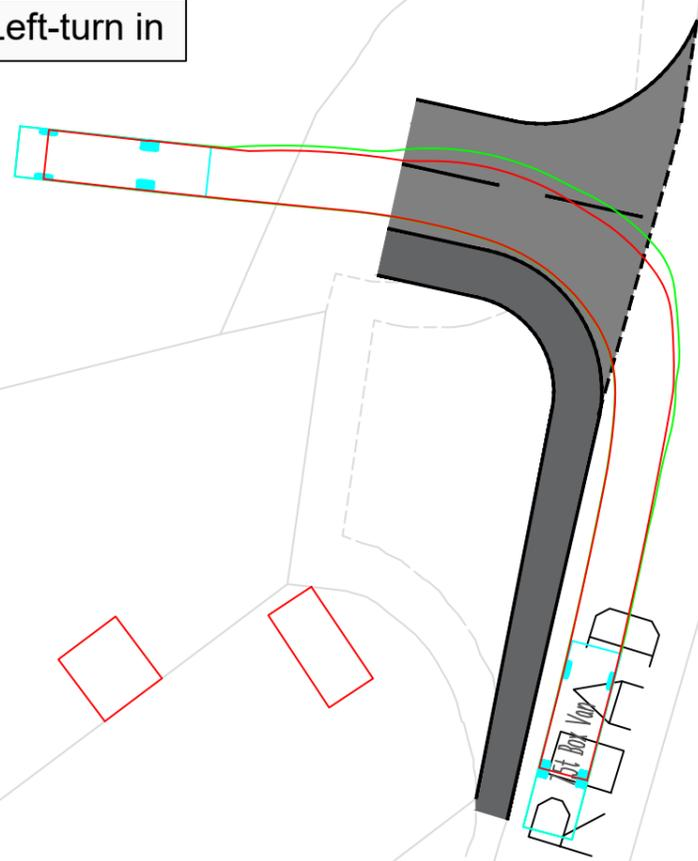

Delivery Van - Left-turn out

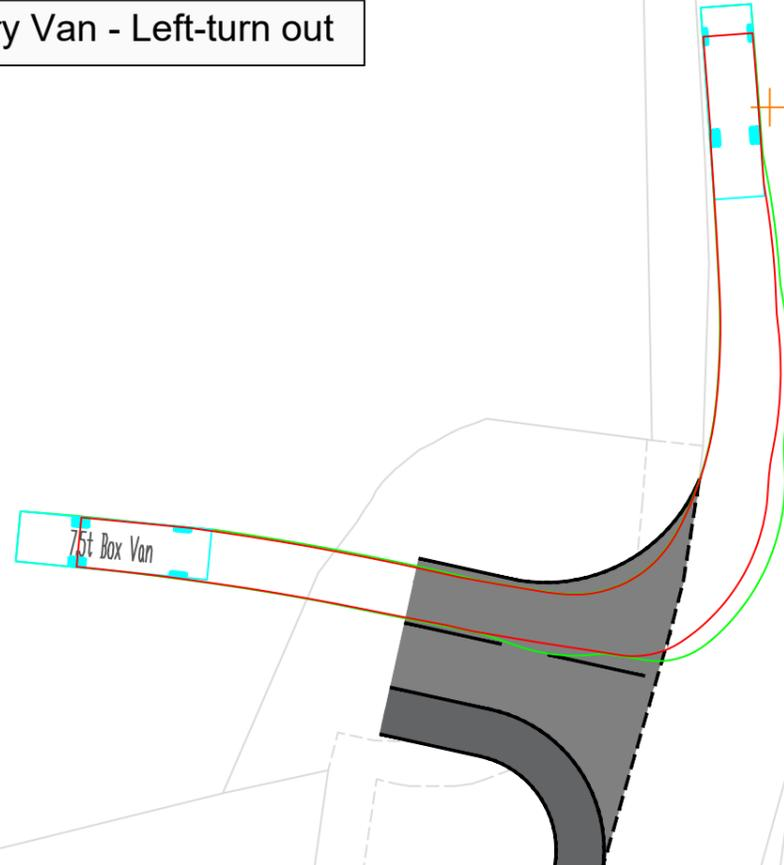

Langley

Delivery Van - Right-turn in

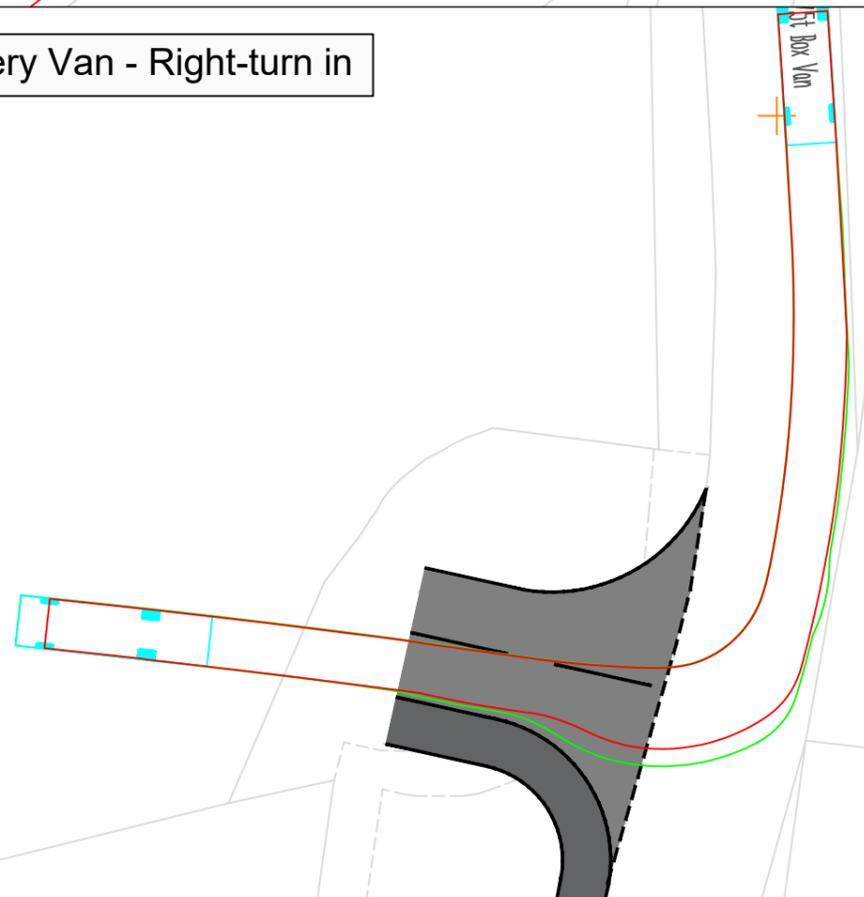

Delivery Van - Right-turn out

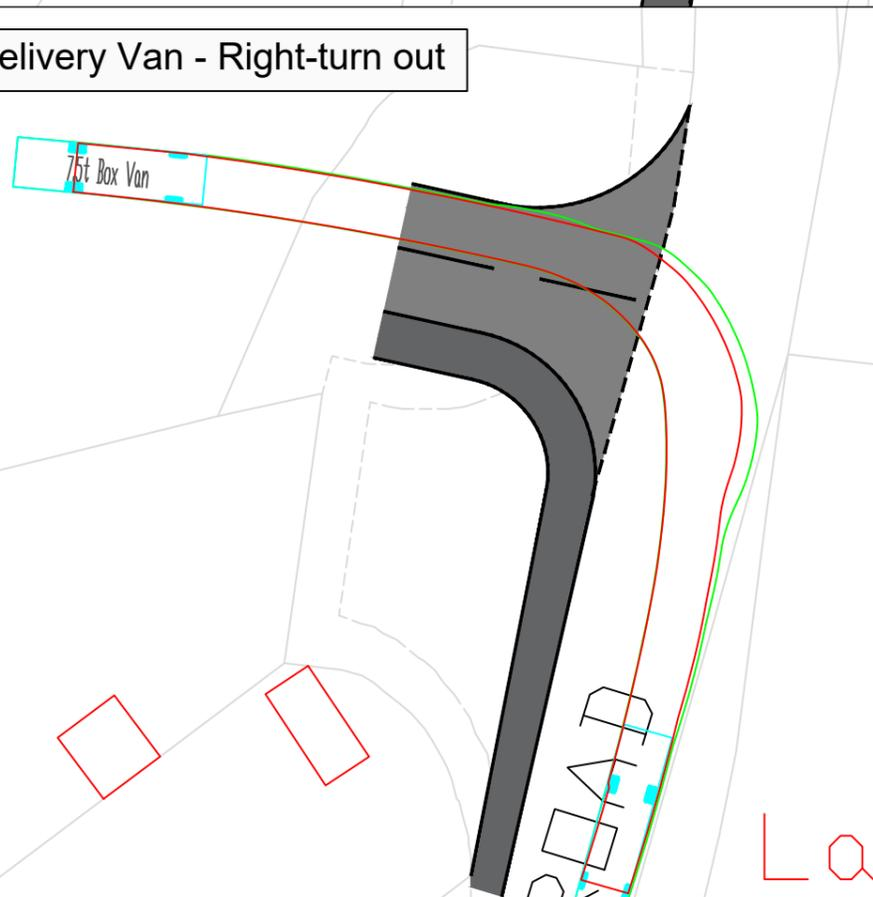

12.5m

Langley

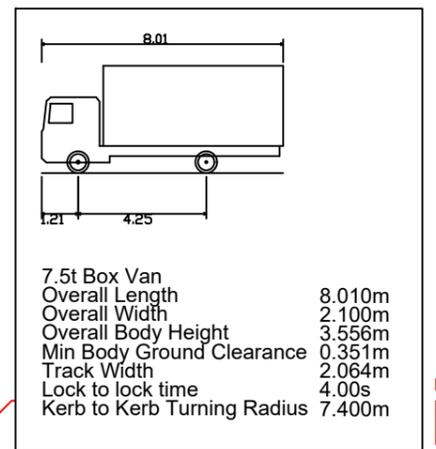

7.5t Box Van  
Overall Length 8.010m  
Overall Width 2.100m  
Overall Body Height 3.556m  
Min Body Ground Clearance 0.351m  
Track Width 2.064m  
Lock to lock time 4.00s  
Kerb to Kerb Turning Radius 7.400m

# Land to rear of Langley Close, Magor

Monmouthshire County Council Sites  
Site Access Considerations



Refuse Vehicle - Left-turn in

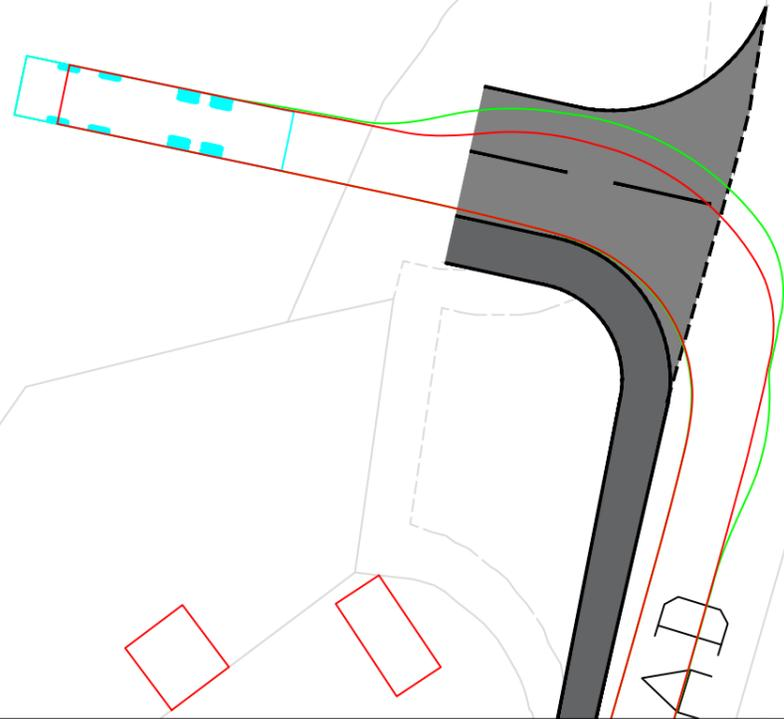

Refuse Vehicle - Left-turn out

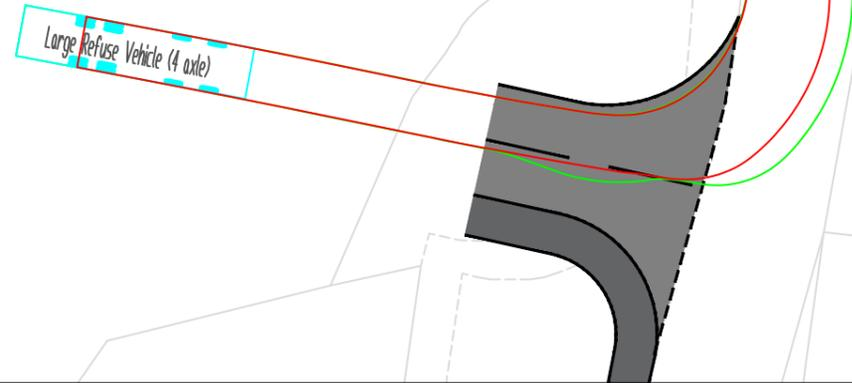

12.5m

Refuse Vehicle - Right-turn in

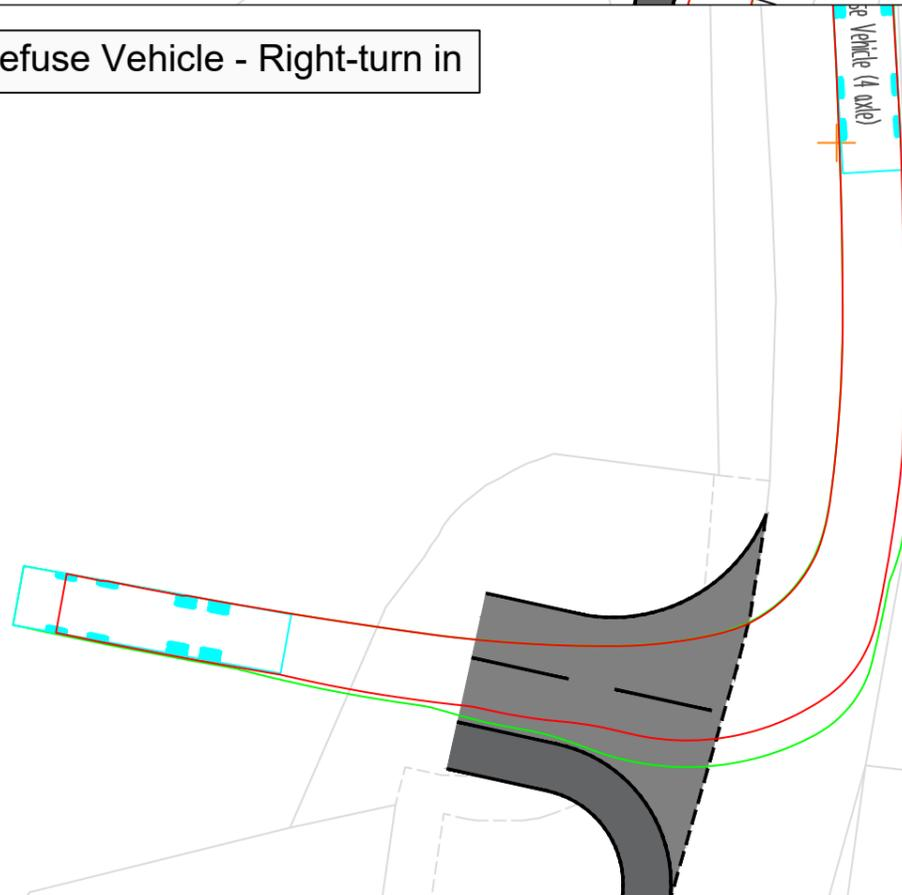

12.5m

Refuse Vehicle- Right-turn out

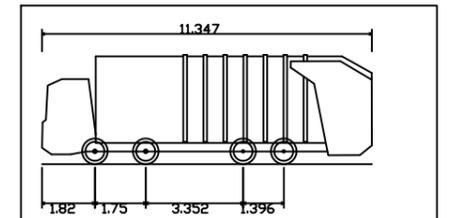
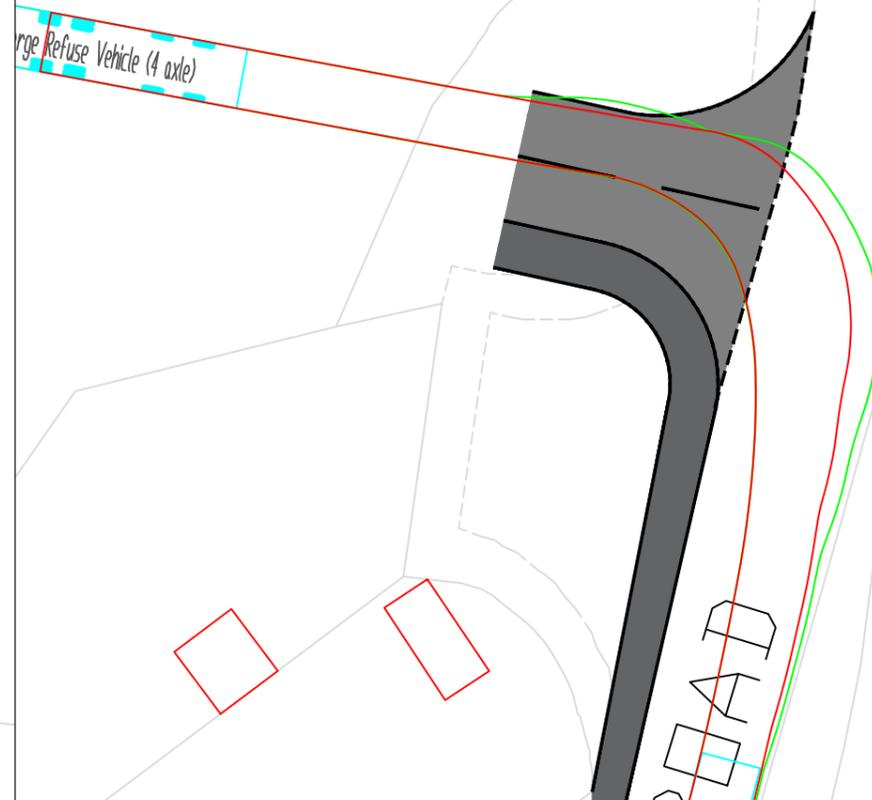

Large Refuse Vehicle (4 axle)	
Overall Length	11.347m
Overall Width	2.500m
Overall Body Height	3.751m
Min Body Ground Clearance	0.304m
Track Width	2.500m
Lock to lock time	6.00s
Wall to Wall Turning Radius	11.330m

# Land to rear of Langley Close, Magor

Monmouthshire County Council Sites  
Site Access Considerations



This page is intentionally left blank

---

Project:	<b>Monmouthshire County Council Sites</b>	Job No: <b>60720932</b>
Subject:	<b>Land At Bradbury Farm, Crick</b>	
Prepared by:	<b>Ben Burton (Senior Consultant)</b>	Date: <b>15/05/2024</b>
Checked by:	<b>Spiro Panagi (Associate Director)</b>	Date: <b>16/05/2024</b>
Approved by:	<b>Spiro Panagi (Associate Director)</b>	Date: <b>16/05/2024</b>

---

## Appendices:

### Appendix A Site Access Considerations

#### 1. Introduction

This Technical Note (TN) has been prepared by AECOM to support the investigation into three sites for a potential Traveller settlement land use. The transport planning inputs will inform the assessment of the sites in the consideration for inclusion with the forthcoming Monmouthshire County Council (MCC) Replacement Local Development Plan (RLDP).

The three sites which have been identified for consideration are 'Land to rear of Langley Close, Magor', 'Land at Oak Grove Farm, Portskewett' and 'Land at Bradbury Farm, Crick'. It is understood that the scale of development for any potential site would be up to around 11 dwellings, to be comprised of temporary structures, potentially in the form of prefabricated units.

This TN discusses the transport considerations associated with 'Land at Bradbury Farm, Crick' and includes the following:

- Consideration of local Planning Policy and this specific land use requirement;
- Baseline reporting on existing transport infrastructure for all modes;
- Forecasts of trip generation based on local knowledge, client forecasts and industry standard software TRICS;
- Description of development proposals and review against the Council parking and design standards; and
- Consideration of the proposed access and how that could appropriately continue to serve the proposed site.

#### 2. Planning Policy Context

The Monmouthshire County Council Local Development Plan (LDP) 2011-2021 was adopted on 27 February 2014, replacing the Monmouthshire Unitary Development Plan (UDP), to become the adopted development plan for the County.

Policy H8 '*Gypsy, Traveller and Travelling Showpeople Sites*' provides the framework for assessing proposals for Traveller sites, whether for permanent, transit or emergency use. Proposals for Traveller sites are assessed against the following criteria, whereby sites:

- *"Would enable the established need to be met at a location that is accessible to schools, shops and health care, by public transport, on foot or by cycle;*
- *Have a safe and convenient access to the highway network and will not cause traffic congestion or safety problems;*

- *Are of a suitable size to allow for the planned number of caravans, amenity blocks, a play area (for children on sites housing multiple families), the access road and include sufficient space for the parking and safe circulation of all vehicles associated with occupiers within the site curtilage;*
- *Do not occupy a prominent location and are consistent with LDP policies for protecting and enhancing character and distinctiveness of the landscape and environment. Where necessary the proposal will include mitigating measures to reduce the impact, and assimilate the proposal into its surroundings e.g. screening and landscaping;*
- *Avoid areas at high risk of flooding and proximity to uses with potential sources of pollution or emissions;*
- *Are of an appropriate scale to their location and do not have an unacceptable impact on the amenities of neighbouring land uses;*
- *Are served, or can be served, by adequate on-site services for water supply, power, drainage, sewage disposal and waste disposal (storage and collection), and for Travelling Showpeople that there is a level area for outdoor storage and maintenance of equipment.”*

In terms of transport and highways, the material considerations include accessibility to local facilities and communities, safe and convenient access to the highway network and an acceptable level of traffic impact, and the ability for vehicles to be safely accommodated by internal access routes and parking facilities.

### **3. Baseline Transport Conditions**

#### Local Highway Network

Access to the proposed site at Bradbury Farm would be taken from Crick Road. Crick Road consists of a single carriageway and comprises a link approximately 1.5km in length, between the A48 (to the north) and the B4245 (to the south). Crick Road has a variable carriageway width within the vicinity of the site, varying between 6.5-7.5m and is subject to a speed limit of 60mph. Approximately 170m to the north of the site, the speed limit is reduced to 30mph on the approach to a cluster of existing dwellings. The 30mph speed limit is in place for approximately 20m, before the speed limit is reduced further to 20mph, with Crick Road providing access to residential properties on either side of its approach to the A48. At the approach to the A48 speed restriction is increased to a 40 mph route.

Crick Road connects to the A48 via a priority T-Junction, approximately 350m to the north of the site. To the west of Crick Road, the A48 is dualled, with an additional lane created in the eastbound direction, for right-turners into Crick Road. To the east of Crick Road, the A48 is a single carriageway with one lane in each direction. In the westbound direction, ghost island right-turn bays are provided for access to facilities located to the north of the A48. In the vicinity of its junction with Crick Road, the A48 is subject to a 40mph speed limit. The speed limit is increased to 50mph in the westbound direction, approximately 100m to the west of Crick Road. In the eastbound direction, the A48 becomes subject to a 50mph speed limit approximately 400m to the east of Crick Road, to the east of the M48 overbridge.

The A48 provides a strategic connection towards Junction 2 of the M48, to the east of the site at Thornwell, via the A466. The A48 continues northeast towards the A466 and Chepstow. To the west, the A48 routes from Parkwall Roundabout towards Newport and Junction 24 of the M4.

Approximately 1km to the south of the site, Crick Road meets the B4245 via a priority T-Junction. The B4245 is a single carriageway road that provides access to the A48 to the east and towards Caldicot to the west. The B4245 has an average carriageway width of approximately 7.5m. The majority of the B4245, to the east of Crick Road, has a speed limit of 60mph.



## Walking and Cycling Environment

There is provision for walking or cycling on Crick Road in the locality of the proposed site. Approximately 190m to the north of the site and adjacent to Walnut Grove, a 2m footway is present on the western side of the carriageway. This footway provision terminates approximately 65m further to the north, with no further provision available on either side of Crick Road. To the north of the site along the A48, there are footways present on both sides of the carriageway, providing walking / cycling access to local facilities in Crick.

There are no existing designated active travel routes located within close proximity of the proposed site. A set of Integrated Network Maps was submitted by MCC to the Welsh Government, which set out the Council's plans for improving active travel over the following 15 years. A future cycling route has been identified (ref. MCC-S24B) which crosses Crick Road approximately 550m to the south of the site. The route has been set as a long-term aspiration and would comprise a largely off-road route towards Chepstow, to the northeast of the site. Another long-term route has been identified along the A48 (ref. MCC-S28B) in the vicinity of Crick. The route is designated for walking and cycling and would seek to improve the walking / cycling connection between Crick and Caerwent to the west.

Monmouthshire's Public Rights of Way (PRoW) mapping has been consulted to determine whether any existing routes pass through, or close by, to the site. Footpath ref. 376/25/1 lies to the southwest of the site, approximately 330m from the southern boundary, and connects to a network of PRoWs, including ref. 354/79/1 and 354/79/2, which provide access into Caldicot to the west.

National Cycle Network (NCN) Route 4 is available approximately 350m to the north of the site along the A48 at Crick. NCN Route 4 provides a long-distance route between Newport and Chepstow, as well as to destinations located further-afield. To the northeast, NCN Route 4 leaves the A48 and provides access to Chepstow via quieter routes. Heading west along the A48, NCN Route 4 continues into the village of Caerwent, before routeing southeast through Caldicot, where access is provided to both Caldicot and Severn Tunnel Junction railway stations.

There is potential for the site to benefit from improvements to walking and cycling facilities to the south of the site along Crick Road, which may be delivered as part of the emerging proposals for two Candidate Sites, which are being developed as part of MCC's RLDP. These have not been specifically discussed within this report as the current status is not known.

## Public Transport Accessibility

The IHT's *Guidance for Providing for Public Transport in Developments*, published in 1999, suggests 400m as the 'acceptable' walking distance to a bus stop. The nearest bus stops to the proposed site are named 'Crick House' and are located on the A48, approximately 400m walking distance from the northern boundary of the site. **Table 3-1** provides a summary of the 73 service, which is available from the bus stops on the A48. Times and frequencies listed are reflective of the latest available timetable.

**Table 3-1: Summary of Local Bus Services**

Service	Route	Days	First Service	Last Service	Approximate Frequency
73	Newport – Chepstow	Mon-Fri	07:09	18:53	Hourly
		Saturday	07:54	16:52	120 minutes
	Chepstow - Newport	Mon-Fri	07:32	19:12	Hourly
		Saturday	10:19	18:19	120 minutes

Source: *Bustimes.org* (May 2024)

In summary, **Table 3-1** demonstrates there is a reasonable availability of local bus services a short distance from the site on the A48. The lack of continuous active travel provision along Crick Road, between the site and the A48, would raise highways safety concerns with regards to public transport accessibility for prospective residents of the development.

It is understood that emerging Candidate Sites, as part of MCC's RLDP, adjoin the site to the south on either side of Crick Road. The current understanding of the high level emerging public transport strategy for these sites could see the introduction of new bus stops along Crick Road. This would appear to be a logical provision given the location and scale of those sites. Should they be installed that may increase the immediate public transport accessibility of the site at Bradbury Farm, with associated improvements to the walking and cycling facilities along this route.

The proposed site lies between two railway stations, Caldicot and Chepstow. The nearest station to the site is Caldicot, which lies approximately 2.7km to the southwest. The main services available at Caldicot are Transport for Wales services between Maesteg and Cheltenham, via Cardiff, Newport and Bridgend. On average, a service is available every hour. Ticket machines are available at Caldicot Station, however there are no car or cycle parking facilities provided.

### Local Facilities

There is a lack of local amenities within the immediate locality of the proposed site. The nearest facilities are located within Crick to the north and Caerwent to the northwest. Facilities available in Crick include a care home and a car dealership. To the west in Caerwent, further amenities are available including a farm shop, village hall, community centre, nursery and restaurant. A wider range of facilities lie to the southwest of the site in Caldicot, including a supermarket, leisure centre, industrial employment facilities, doctors and multiple schools.

The potential for improving local public transport provision, as part of the emerging Candidate Sites, would create links to, and opportunities to use facilities which are located beyond typical acceptable walking distance.

### Highway Safety

Personal Injury Collision (PIC) data has been assessed using CrashMap for the most recently available 5-year period (2018-2022) in order to assess the road safety along the network in the vicinity of the site. There have been no PICs recorded in proximity to the site frontage. One 'serious' PIC was recorded on Crick Road approximately 300m to the north of the site, on its approach to the A48. This took place in September 2020 and involved a single vehicle. A further PIC was recorded as 'slight' and occurred in January 2020 at the priority junction between the A48 and Crick Road; one vehicle was involved. These are considered to be isolated incidents that do not suggest there to be an existing highways safety issue that could be exacerbated by the development.

## **4. Potential Trip Generation & Parking Requirement**

It is understood that the scale of development for the site would be around 11 dwellings, to be comprised of temporary structures, potentially in the form of prefabricated units. The Trip Rate Information Computer System (TRICS) database has been used to calculate the proposed trip rate and subsequent trip generation for the proposed development. There are a limited number of Traveller sites available within TRICS, and as such, trip rates have been established using privately owned residential houses, with location types filtered to best represent the characteristics of the site at Bradbury Farm. This is considered to represent a worst case scenario in terms of vehicular trip generation. The trip rates and resultant trip generation in terms of vehicle trips, for the traditional peak hours, are presented in **Table 4-1**.

**Table 4-1: Vehicle Trip Generation – Proposed Development (11 Dwellings)**

Time Period	Trip Rate			Trip Generation		
	Arrivals	Departures	Two-Way	Arrivals	Departures	Two-Way
AM Peak (08.00 – 09.00)	0.173	0.369	0.542	2	5	7
PM Peak (17.00 – 18.00)	0.381	0.188	0.569	5	3	8
Daily (07:00 – 19:00)	2.371	2.405	4.776	27	27	54

Based on the TRICS database, it is anticipated that the proposed development could generate up to seven two-way vehicles trips during the weekday AM peak hour and up to eight two-way vehicle trips during the weekday PM peak hour. There could be up to 54 two-way vehicle trips generated over the course of a day (07:00-19:00). In summary, the anticipated trip generation for the proposed development is low and is unlikely to have a material impact on the highway network.

MCC’s Adopted Parking Standards Supplementary Planning Guidance (SPG) sets out the required parking levels for a range of development types. The SPG sets out four different parking zones within which to classify a specific site; this site is considered to be within ‘Zone 3 – Countryside’. The SPG does not contain specific standards relating to Traveller sites, therefore the following requirements in relation to residential housing are considered to be the most comparable to the development at this stage:

**Table 4-2: Adopted Parking Standards – Residential**

Type	Residents	Visitors
Houses	1 space per bedroom (maximum requirement 3 spaces)	1 space per 5 units

At this stage, the proposed number of bedrooms per unit is unknown and therefore, exact parking requirements for the site would need to be defined once the development design has been sufficiently progressed. Based on the standards above, there would be a requirement for two visitor parking spaces per dwelling on site. Car parking spaces will need to be designed in accordance with the specifications set out in the SPG. As an indication, this includes the requirement to provide standard parking space dimensions of 4.8m x 2.6m.

**5. Site Access Appraisal**

The below discussion appraises the proposed access points into the site and should be read in conjunction with the plans provided within **Appendix A**.

As an initial exercise, preliminary junction designs have been shown at the locations of two existing gated accesses into the site, connecting to Crick Road. An additional, alternative location for access has been identified based on a desktop assessment and complimented by a site visit. This location has been identified approximately midway along the western site boundary, between the two existing gated access locations. At this stage, each preliminary junction shown has been designed with a 6m kerb radii and 5.5m access road carriageway width.

The existing visibility at each potential access location has been based on a 60mph speed limit. In accordance with the Design Manual for Roads and Bridges (DMRB), this equates to visibility requirements of 2.4m x 160m. Vehicular stopping sight distance is comprised of a number of factors including road speed, driver reaction time and vehicle braking. The distance of 160 metres for the existing setting of 60 mph speeds shows how much distance is needed for a driver to see or be seen whilst travelling towards the location of the proposed site access or existing from the access.

Issues have been identified with regard to the two existing gated access locations, at the northern and southern extents of the western site boundary. The visibility splays at both of these locations are shown

to contain significant parcels of land outside of the site boundary, and beyond the likely extent of adopted highway and verge. The alternative access location is shown to work more favourably in terms of visibility, with the majority of land contained within the visibility envelopes comprising hedge / verge adjacent to the highway. This would likely require a far softer engineering solution, as opposed to the visibility constraints observed at the existing site access locations.

**Photos 5-1 to 5-6** have been included below to show the extents of visibility looking left and right at both of the two existing access locations, as well as the alternative access location identified.

**Photo 5-1: Existing Access Location (North) – Visibility (Looking Left)**



**Photo 5-2: Existing Access Location (North) – Visibility (Looking Right)**



**Photo 5-3: Existing Access Location (South) – Visibility (Looking Left)**



**Photo 5-4: Existing Access Location (South) – Visibility (Looking Right)**



**Photo 5-5: Alternative Access Location – Visibility (Looking Left)**



**Photo 5-6: Alternative Access Location – Visibility (Looking Right)**



It is understood that an emerging Candidate Site, as part of MCC’s RLDP, adjoins the site to the south. There is also understood to a significant strategic sized site opportunity opposite this site for around 700 dwellings. Should these plans be realised, this would significantly change the character of the local area and the local highway. It could be that the existing speed limit is reduced to create a better environment and potential connections would need to be explored to link the residential sites to some facilities in the north, including footways and street lighting.

Access proposals for the Candidate Sites are currently being developed and there will be a need to consider any emerging access strategy in the context of these access proposals. This will include, but is not limited to consideration of access junction spacing along Crick Road. In the context of the information which is available at the time of writing, the current understanding of the vehicular access strategy for these sites is that two potential access locations could be created on Crick Road. The indicative layouts suggest these are likely to be positioned in excess of 300 metres to the south of Bradbury Farm and would serve to provide access to Candidate Sites located on either side of Crick Road. At this stage, it could be considered unlikely that the proposed access junction for Bradbury Farm would encroach upon the access strategy for the Candidate Sites. Notwithstanding this, there will be a requirement for ongoing consideration of the interdependencies between access locations along Crick Road, as further details of the Candidate Sites are developed.

Swept Path Analysis (SPA) has been undertaken on the southern existing access location and also on the alternatively proposed access location, approximately midway along the western site boundary. The northern existing access has not been included within this analysis, it considered that the existing level of visibility would not result in an appropriate junction location. This northern junction has therefore been discounted at this stage.

The SPA of the existing and proposed accesses have been undertaken using a large car (5.0m length), delivery vehicle (8.0m length) and a large refuse vehicle (11.3m length). These represent the typical daily movements and servicing requirements for the site. No material issues have been identified with regards

to access / egress of these vehicles. The use of each access option by larger vehicles would require the full width of the access road (see refuse vehicle swept paths as an example), this is generally considered acceptable in street settings. However, it may be determined by the Highway Authority that due to the higher speed of road (outside of a street setting), vehicles should have sufficient room to turn into and out of the access without the need for stopping or giving way, to reduce the potential for collisions on Crick Road. Both potential access locations would appear to have sufficient frontage and visibility to widen the site access if needed and therefore this is considered to be a matter for discussion and clarification rather than a high risk issue. Should it be determined that a larger or more irregular vehicle could be required to deliver prefabricated units or static units, we can work with the team to assess this for both potential access options.

## **6. Conclusions and Recommendations**

Overall, the access appraisal for this site has identified potential visibility issues associated with the two existing access locations, at the northern and southern extents of the site's western boundary. An additional, alternative location for access has been identified based on a desktop assessment and complimented by a site visit. This location has been identified approximately midway along the western site boundary, between the two existing gated access locations. The alternative access location is shown to work more favourably in terms of visibility, with the majority of land contained within the visibility envelopes comprising hedge / verge adjacent to the highway.

It is understood that emerging Candidate Sites, as part of MCC's RLDP, adjoins the site to the south and could exist opposite the site location. Access proposals for the Candidate Site are currently being developed and there will be a need to consider any emerging access strategy in the context of these access proposals. This will include, but is not limited to consideration of access junction spacing along Crick Road. At this stage, it could be considered unlikely that the proposed access junction for Bradbury Farm would encroach upon, or prejudice the access strategy for the Candidate Sites. There will be a requirement for ongoing consideration of the interdependencies between access locations along Crick Road, as further details of the Candidate Sites are developed.

For the residential type of land use proposed, considerations for this site should include the lack of sustainable transport facilities surrounding the site, with no footway connections available on Crick Road, within reasonable proximity of the site. The site is positioned in a rural setting to the south of Crick, and as such has very little supply of complimentary facilities / amenities in close proximity to the site. This could lead to the site being largely car-dominated in terms of incoming and outgoing trips, with little opportunity available for the uptake of active travel modes or use of sustainable transport in the form of buses or trains.

It may be that this site could become more connected and well placed through the delivery of local residential development which would likely require the introduction of a new route character on Crick Road. The anticipated changes would be public transport connectivity, speed limit reductions, footway provision and potential cycle route connections.



Appendix A

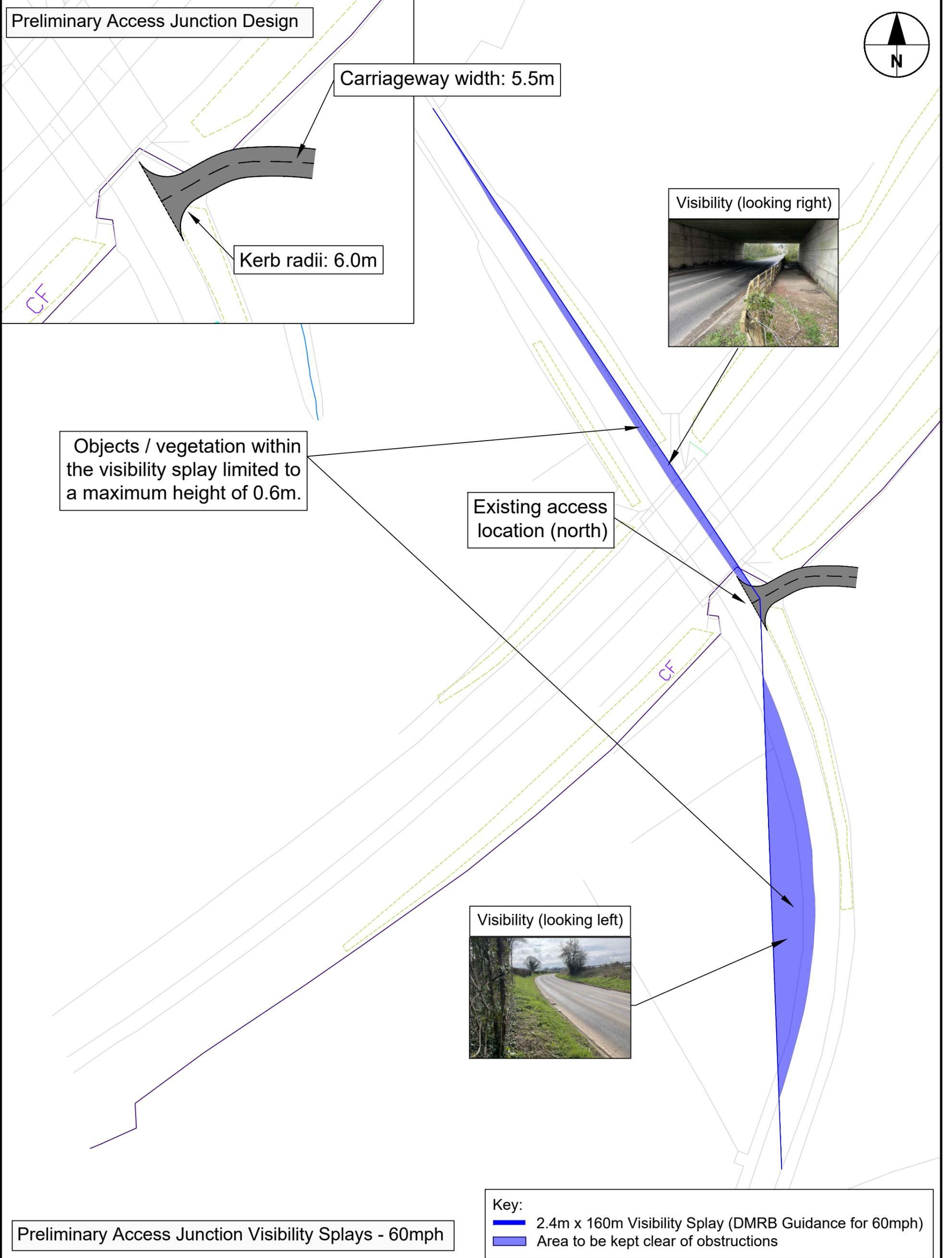

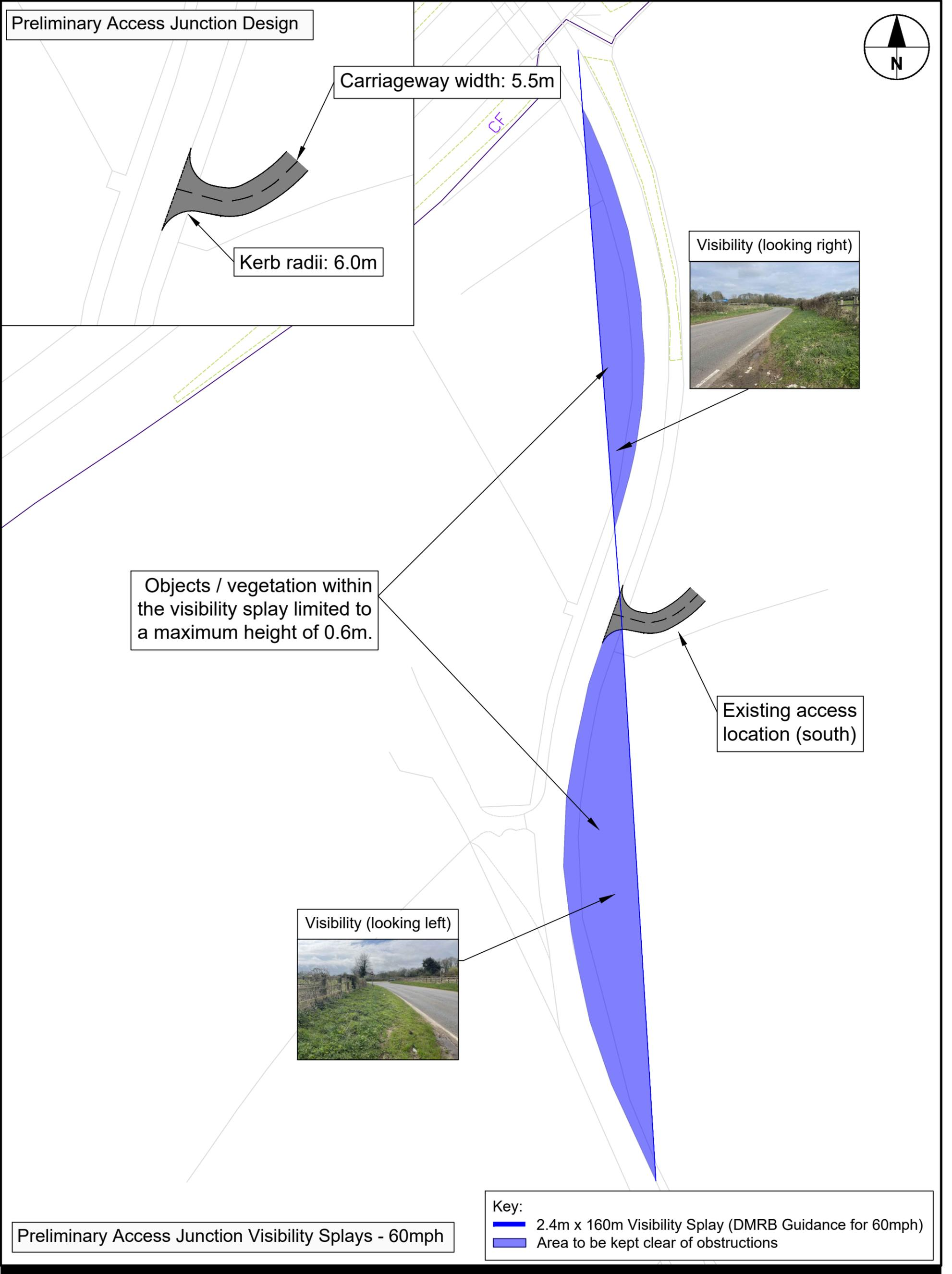

# Land at Bradbury Farm, Crick

Monmouthshire County Council Sites

Site Access Considerations - Existing Access Location (South) - Visibility Splays

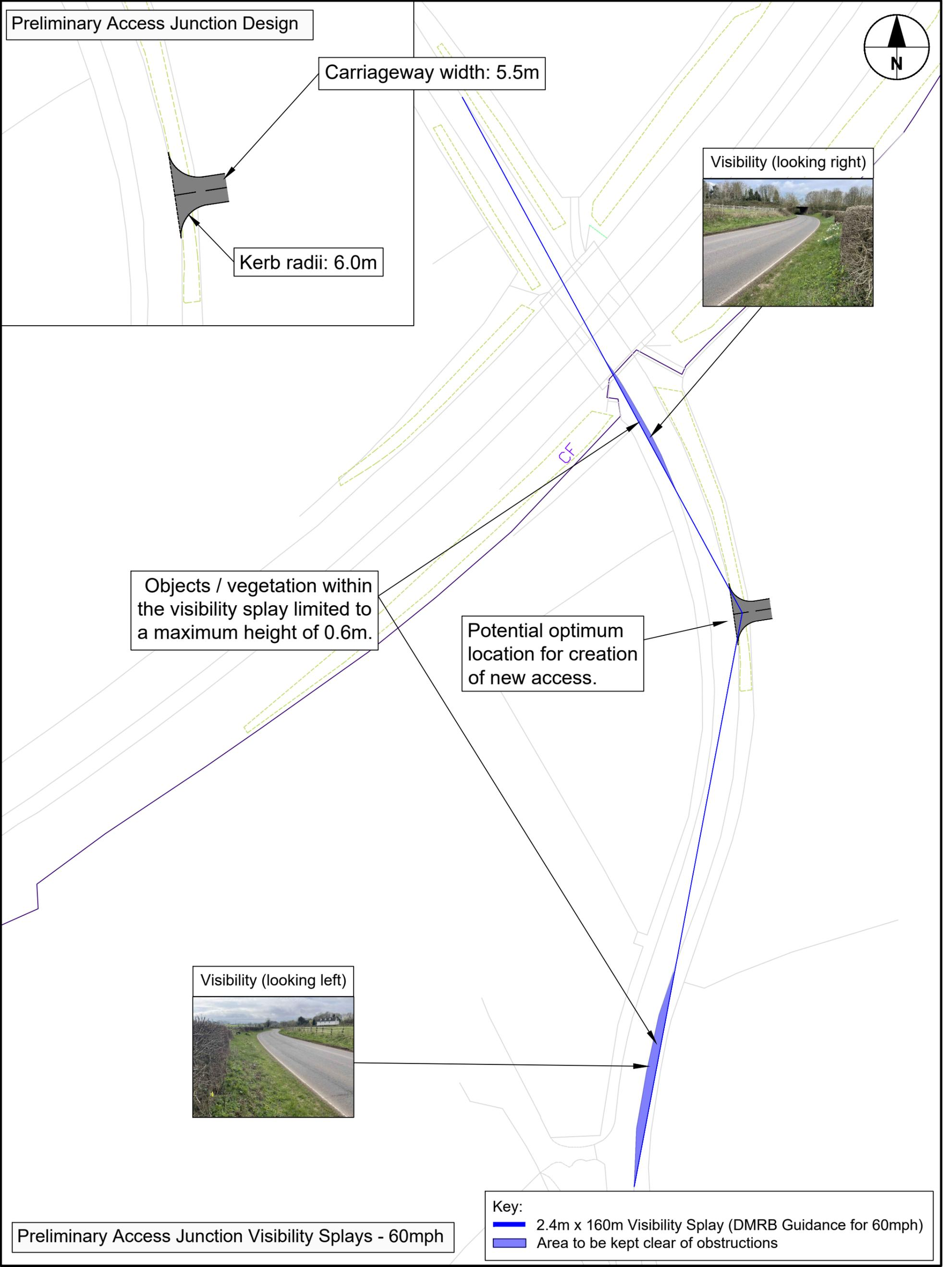

# Land at Bradbury Farm, Crick

Monmouthshire County Council Sites

Site Access Considerations - Alternative Access Location - Visibility Splays

Large Car - Left-turn in

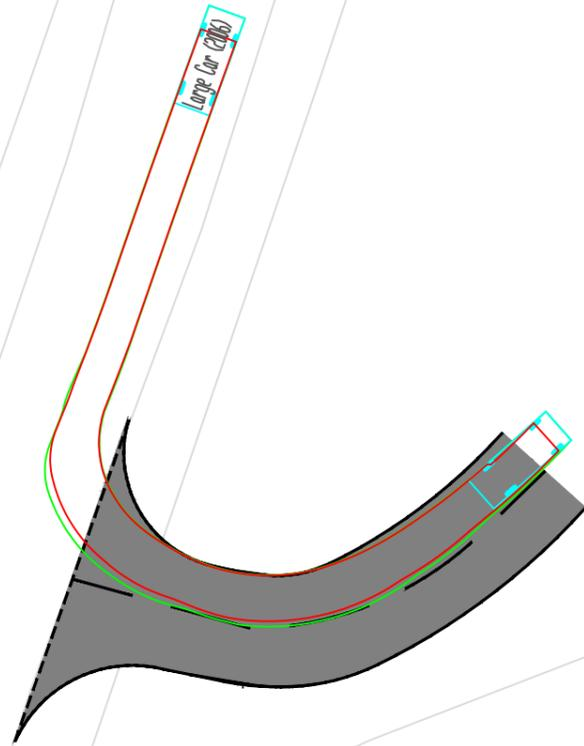

Large Car - Left-turn out

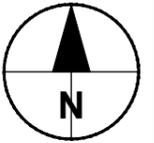
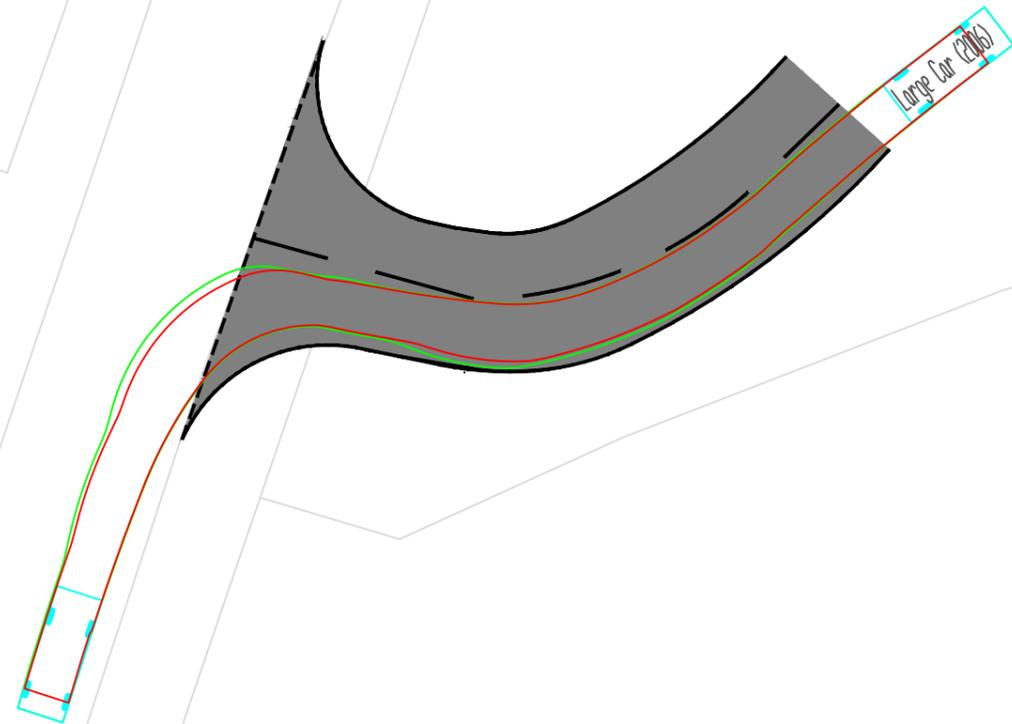

Large Car - Right-turn in

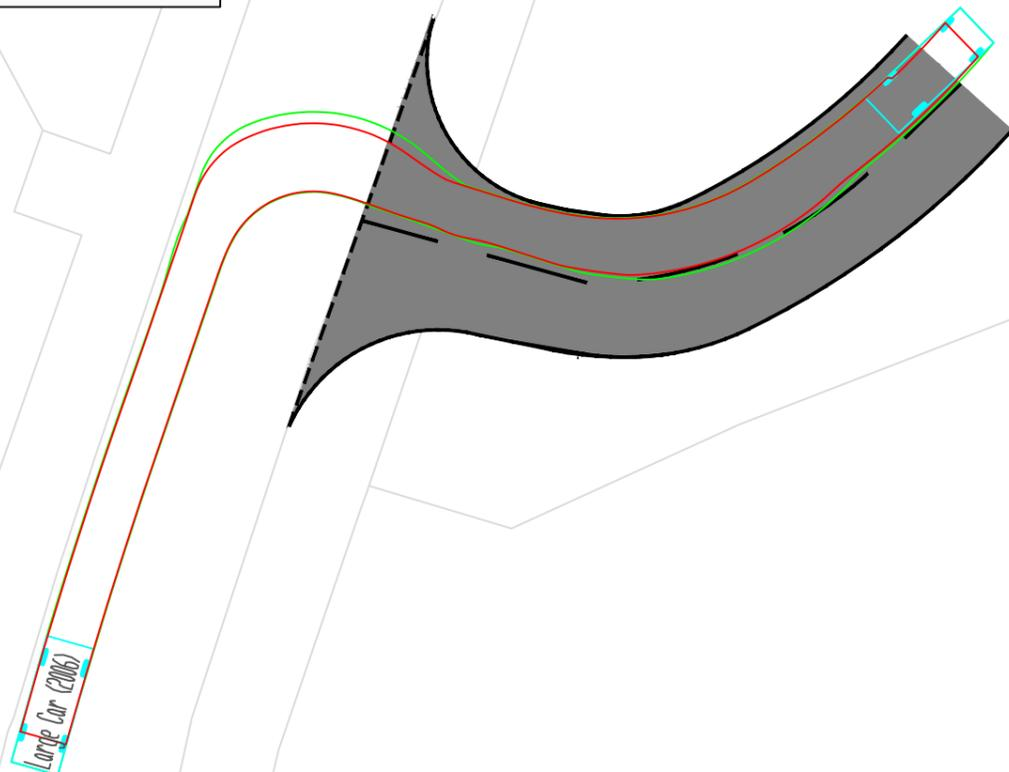

Large Car - Right-turn out

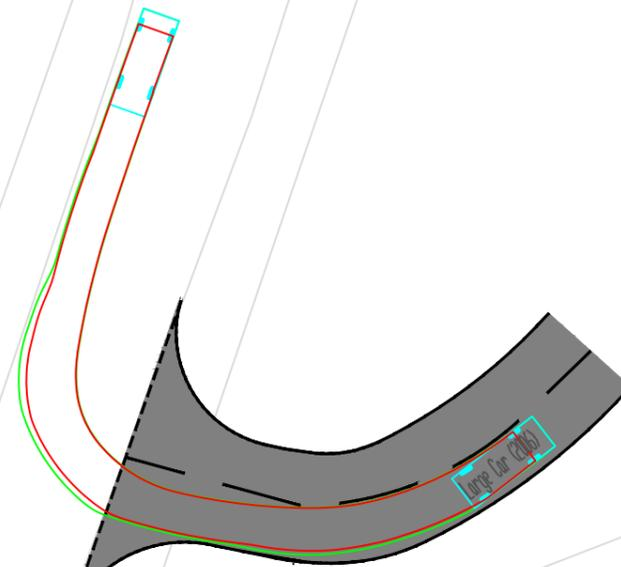

Large Car (2006)	
Overall Length	5.079m
Overall Width	1.872m
Overall Body Height	1.525m
Min Body Ground Clearance	0.310m
Max Track Width	1.831m
Lock to lock time	4.00s
Kerb to Kerb Turning Radius	5.900m

Delivery Van - Left-turn in

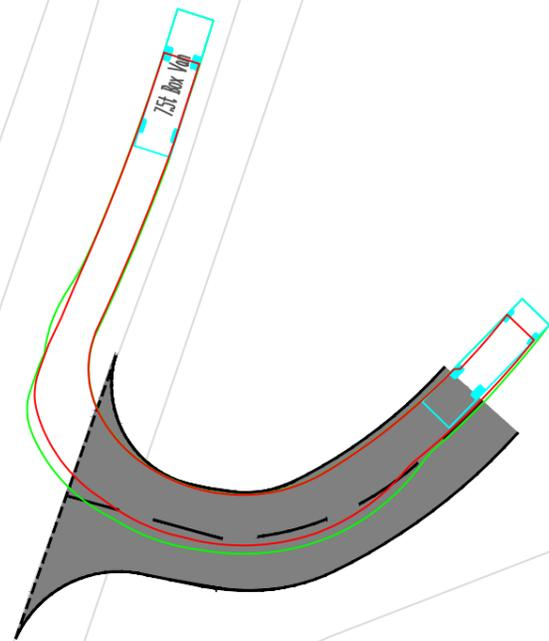

Delivery Van - Left-turn out

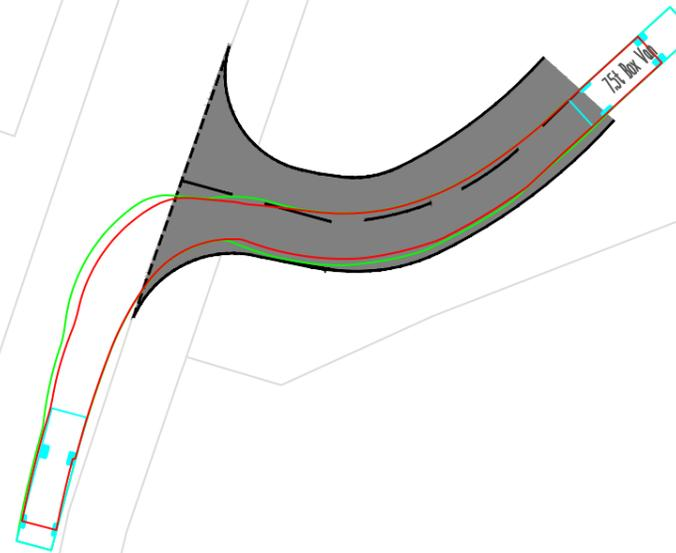

Delivery Van - Right-turn in

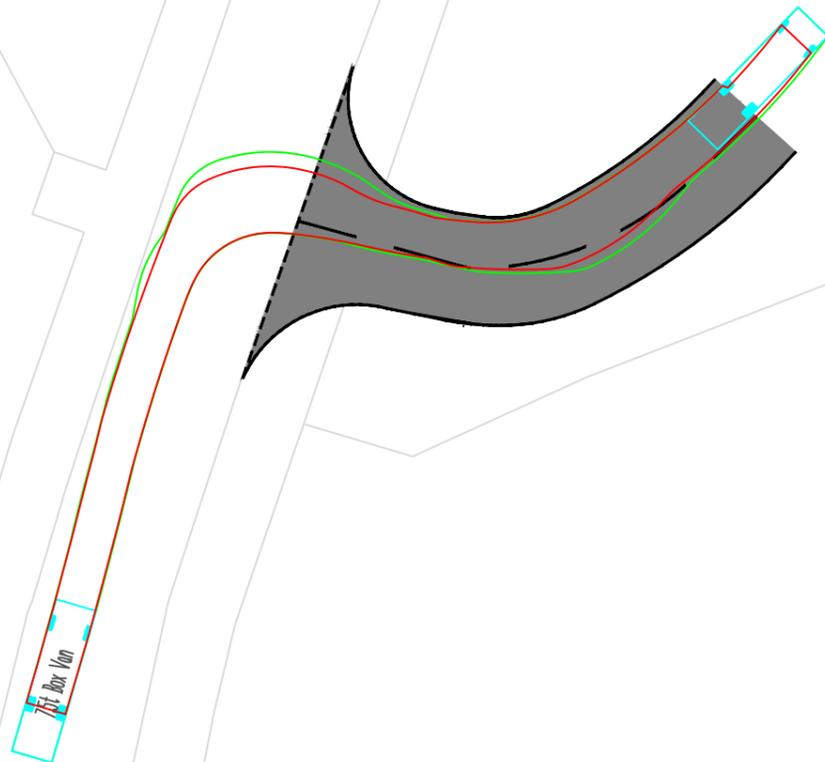

Delivery Van - Right-turn out

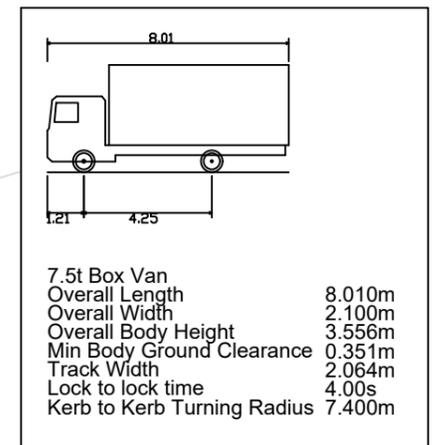
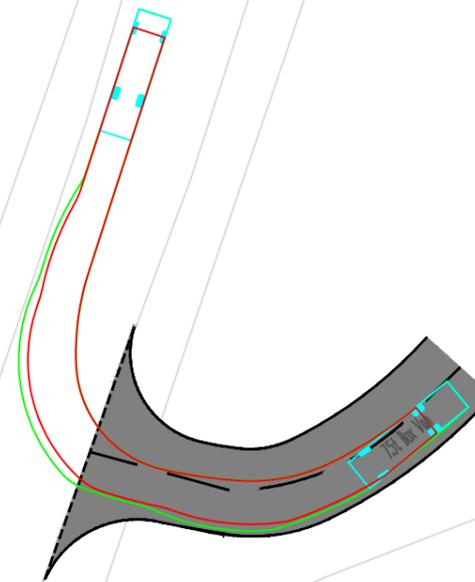

Refuse Vehicle - Left-turn in

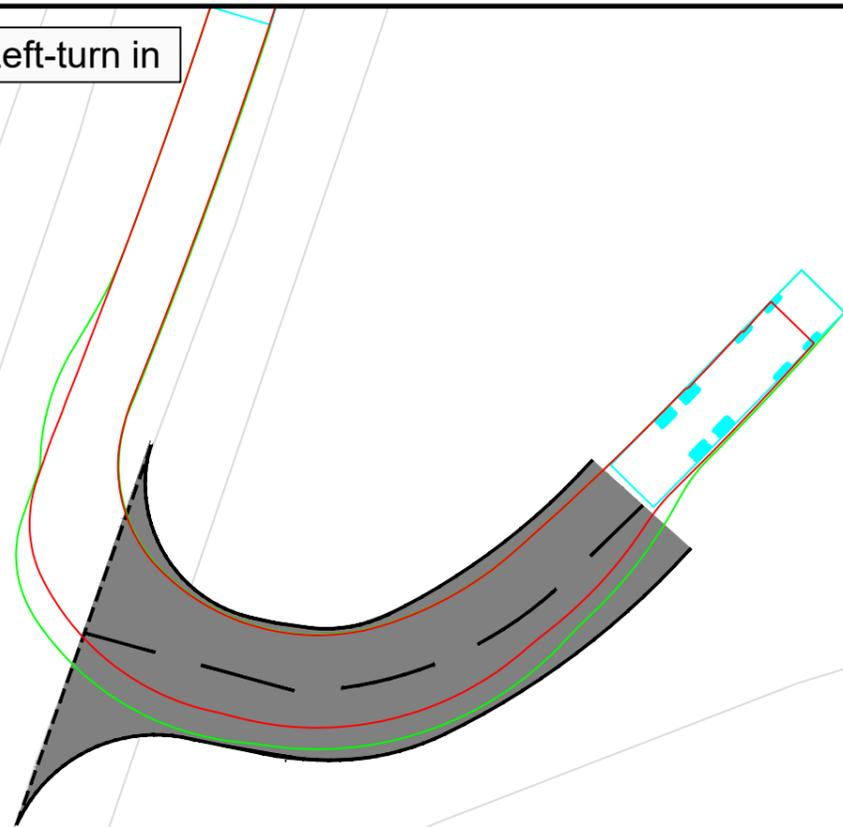

Refuse Vehicle - Left-turn out

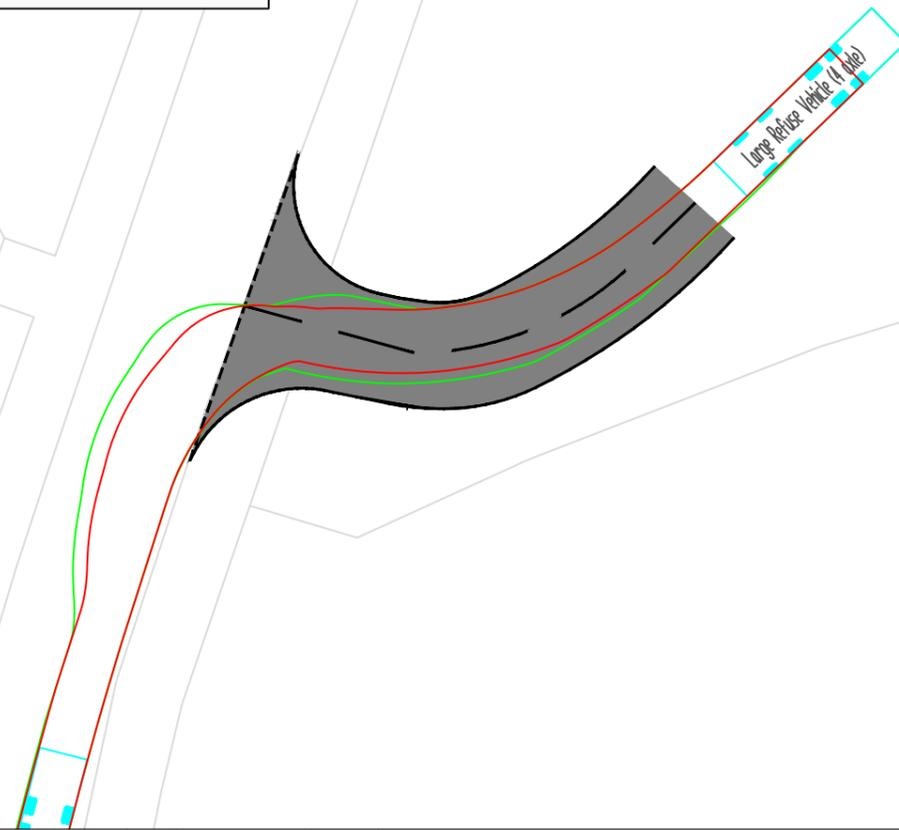

Refuse Vehicle - Right-turn in

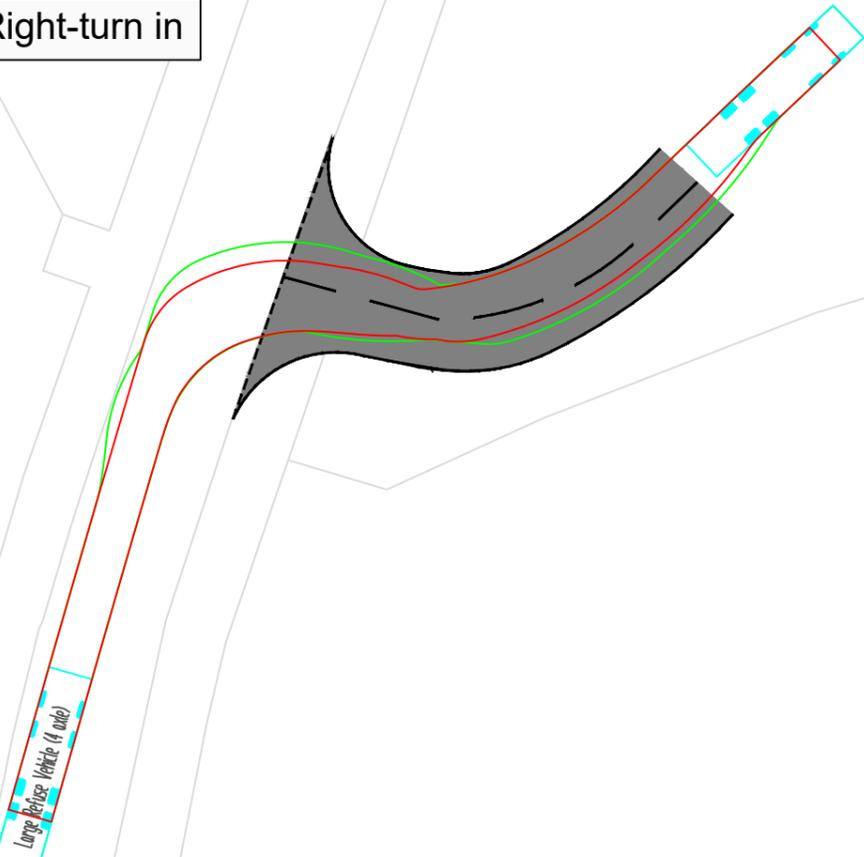

Refuse Vehicle- Right-turn out

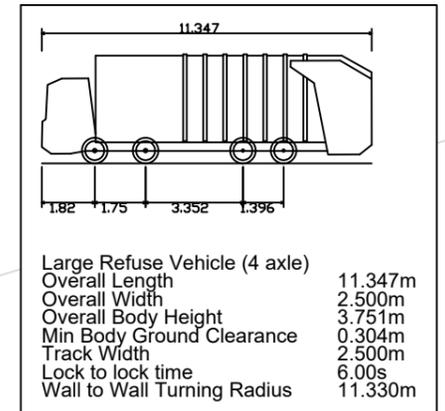
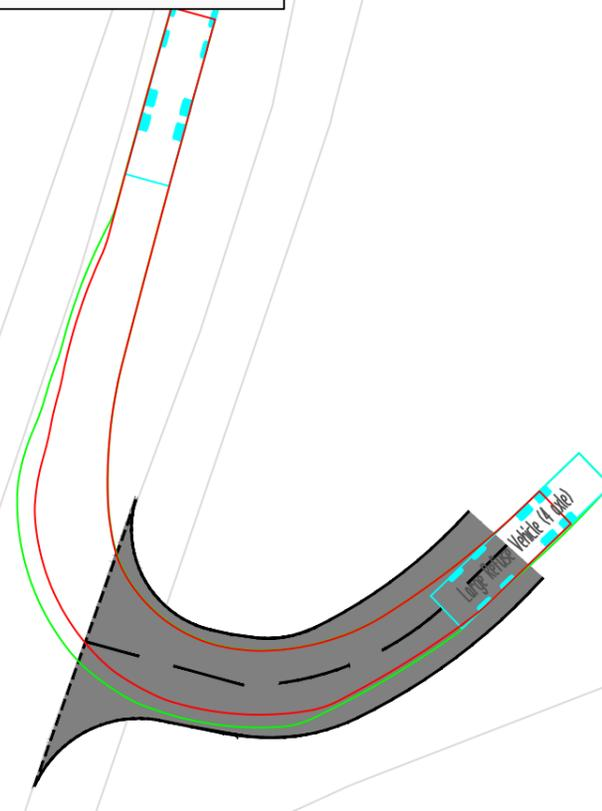

Large Car - Left-turn in

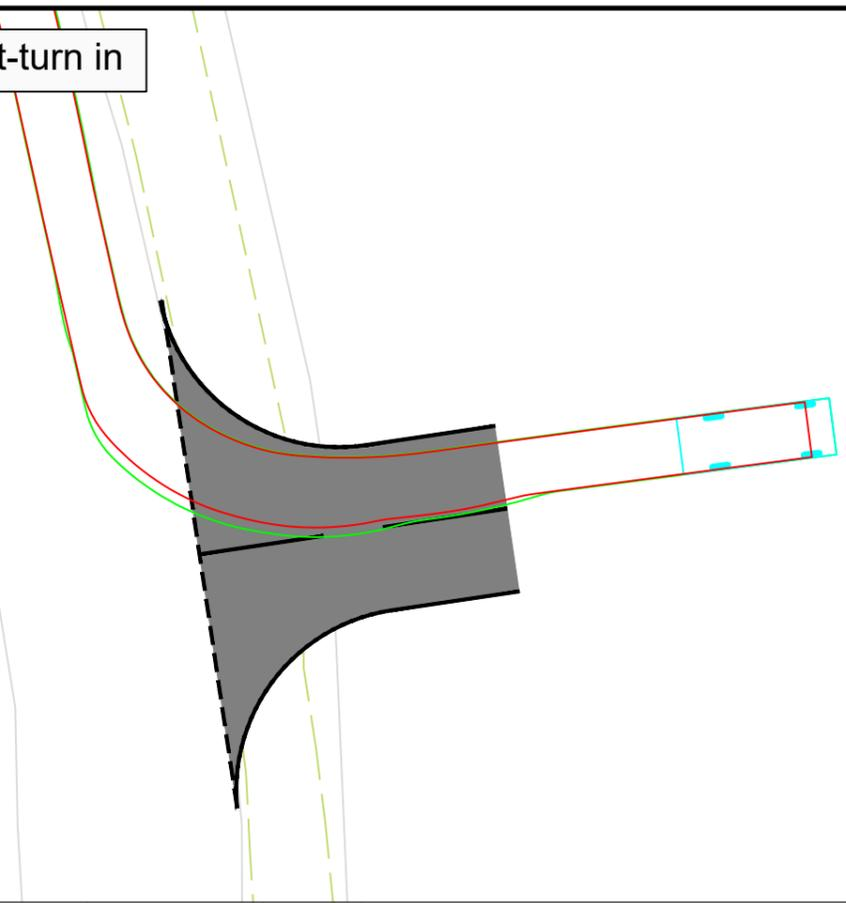

Large Car - Left-turn out

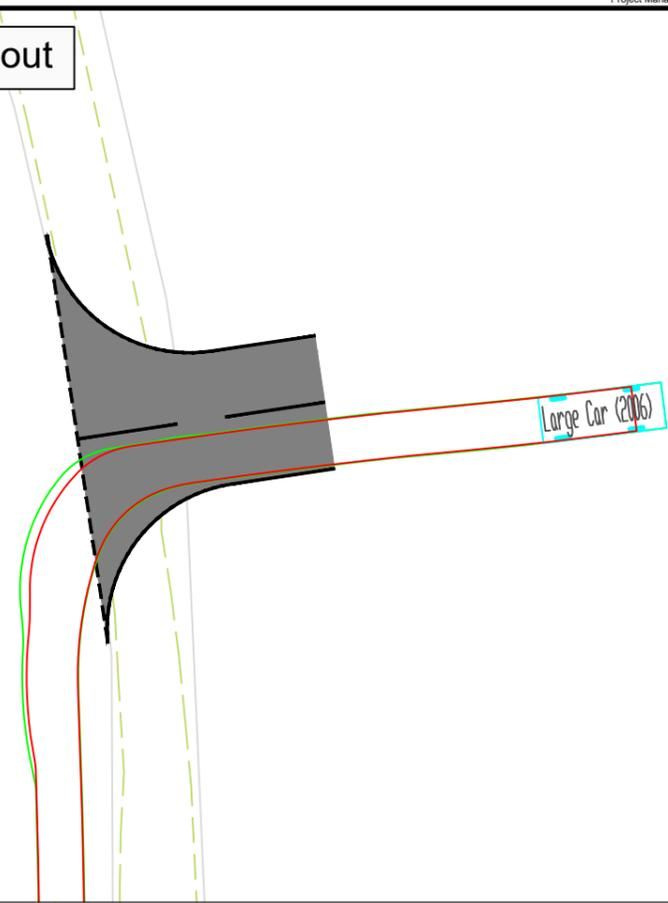

Large Car - Right-turn in

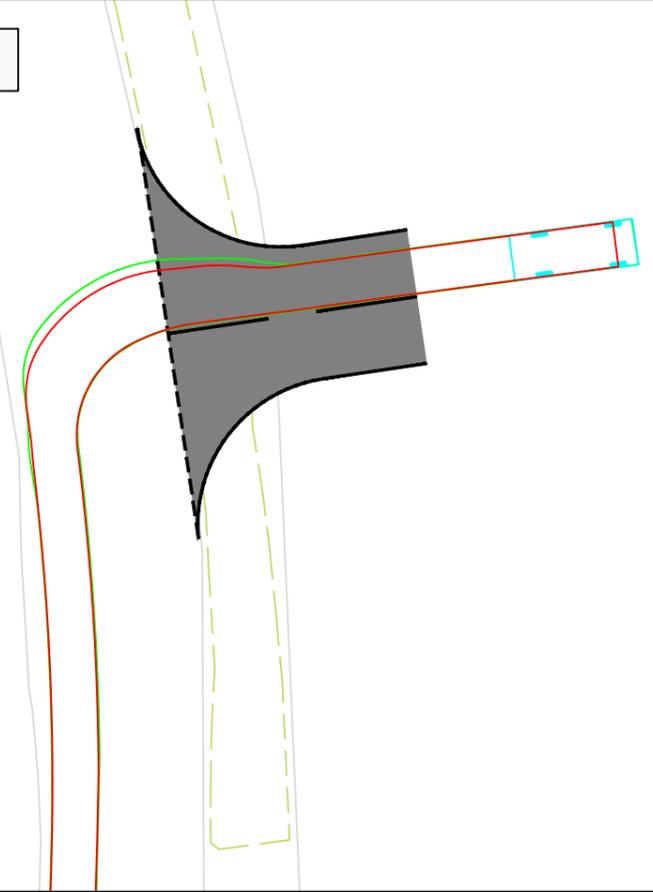

Large Car - Right-turn out

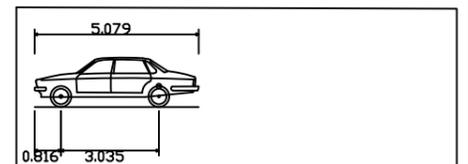
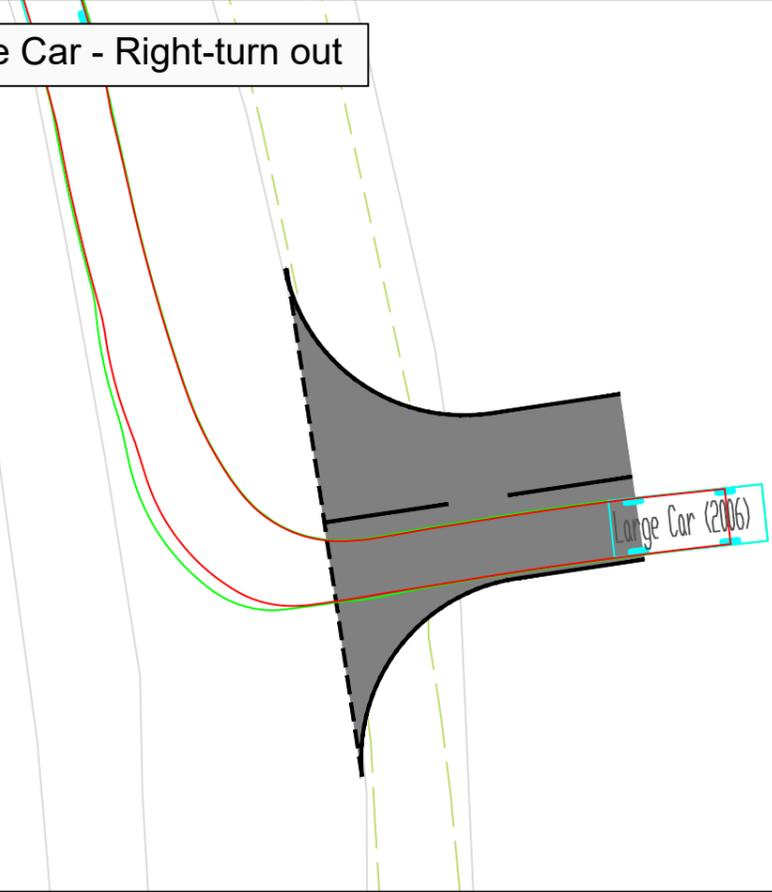

Large Car (2006)	
Overall Length	5.079m
Overall Width	1.872m
Overall Body Height	1.525m
Min Body Ground Clearance	0.310m
Max Track Width	1.831m
Lock to lock time	4.00s
Kerb to Kerb Turning Radius	5.900m



Delivery Van - Left-turn in

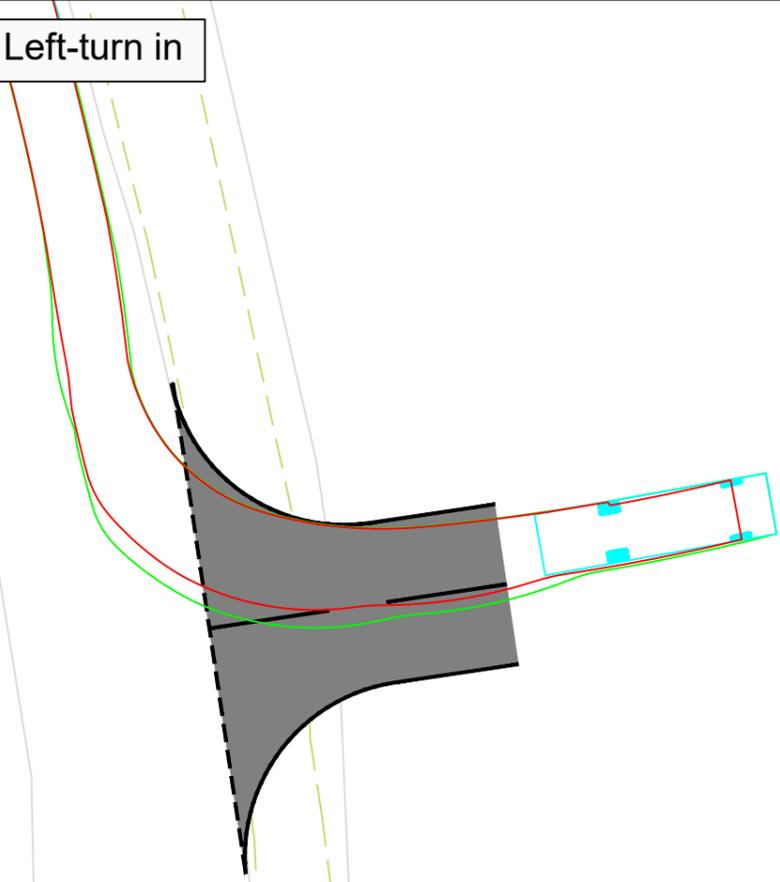

Delivery Van - Left-turn out

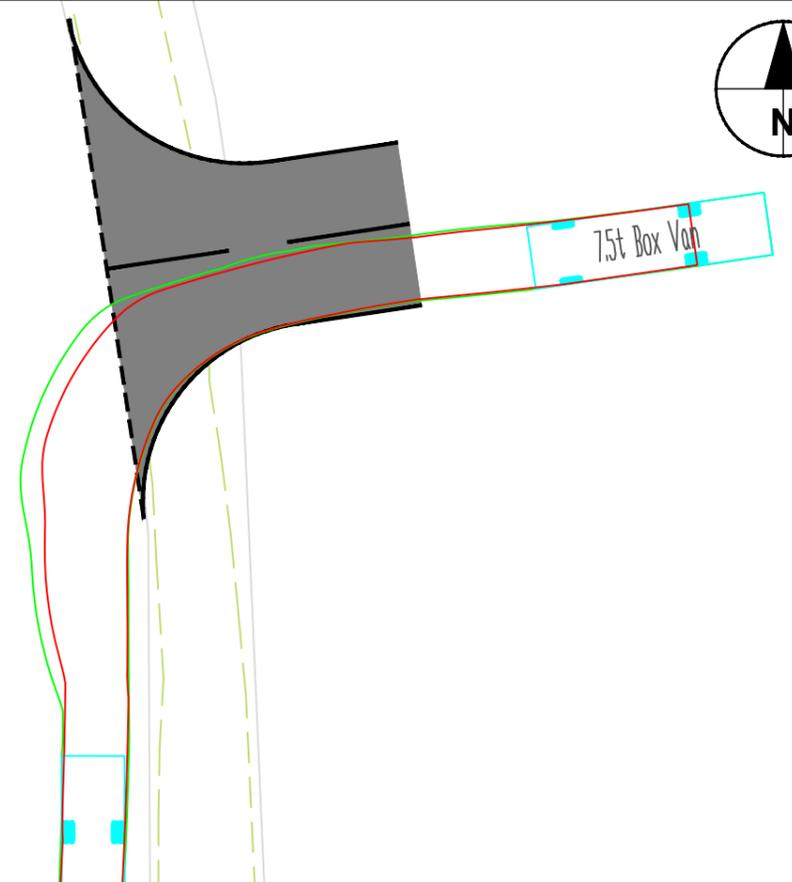

Delivery Van - Right-turn in

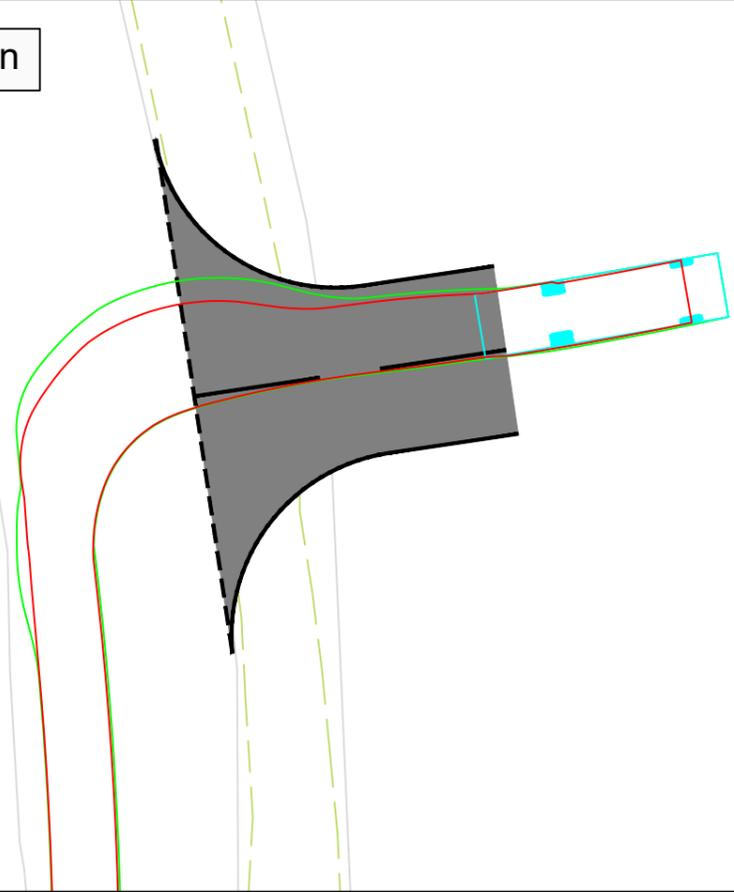

Delivery Van - Right-turn out

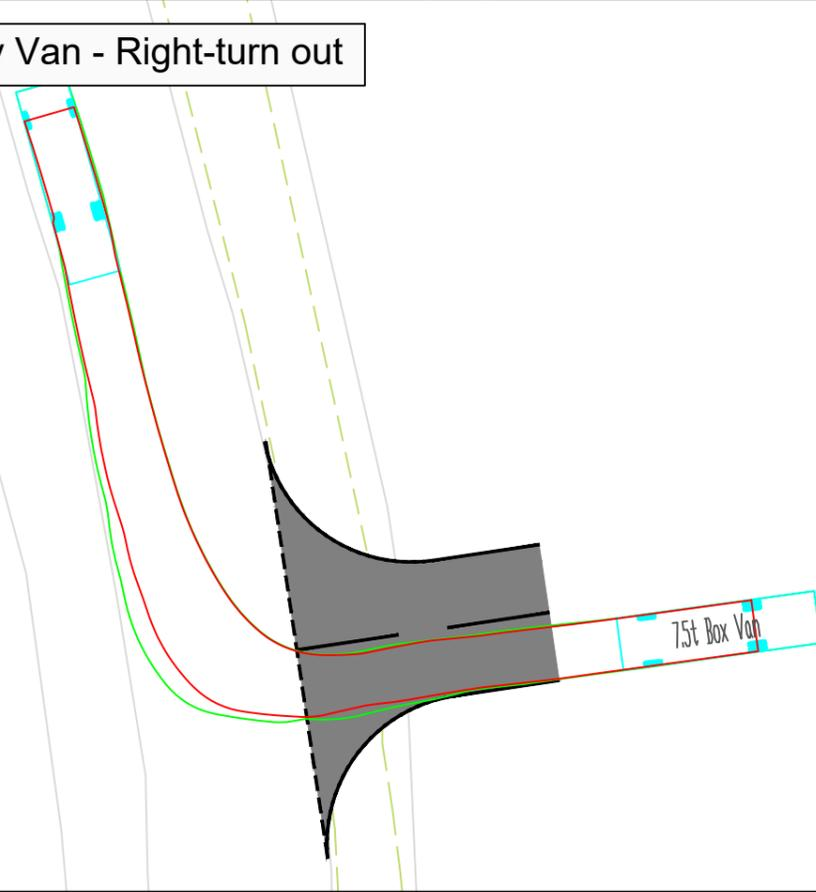

7.5t Box Van	
Overall Length	8.010m
Overall Width	2.100m
Overall Body Height	3.556m
Min Body Ground Clearance	0.351m
Track Width	2.064m
Lock to lock time	4.00s
Kerb to Kerb Turning Radius	7.400m

Page 745

# Land at Bradbury Farm, Crick

Monmouthshire County Council Sites  
Site Access Considerations - Alternative Access Location - SPA



Refuse Vehicle - Left-turn in

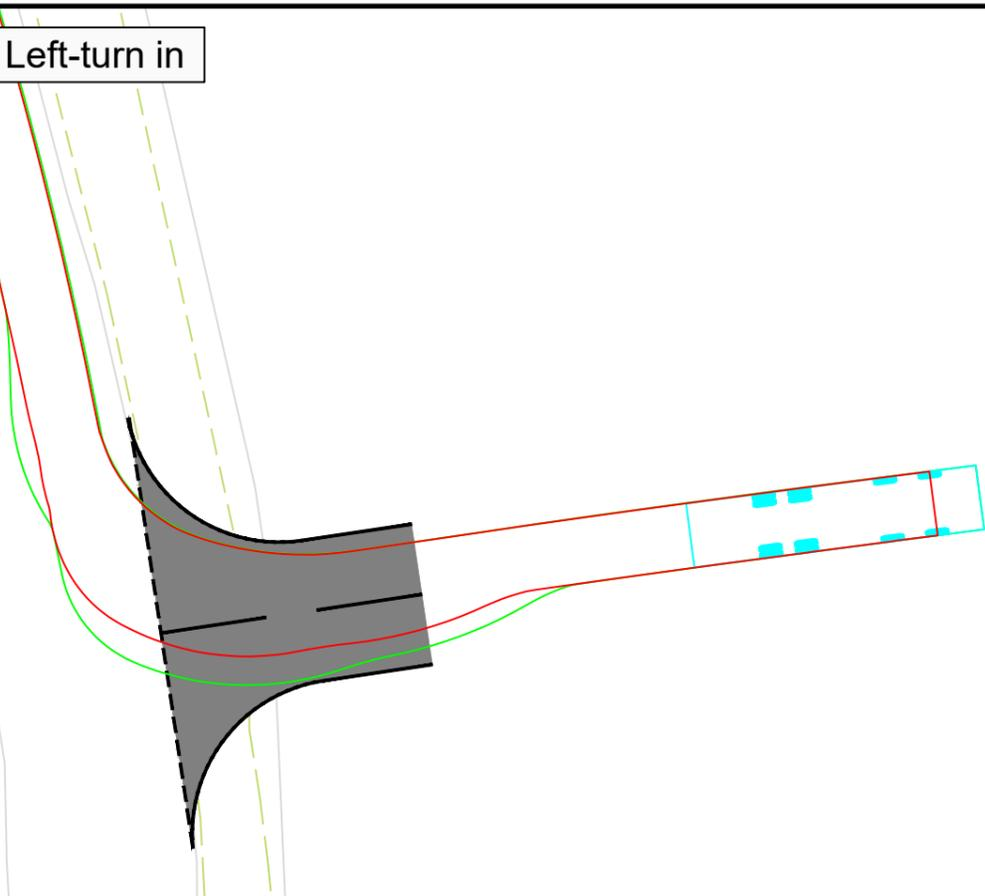

Refuse Vehicle - Left-turn out

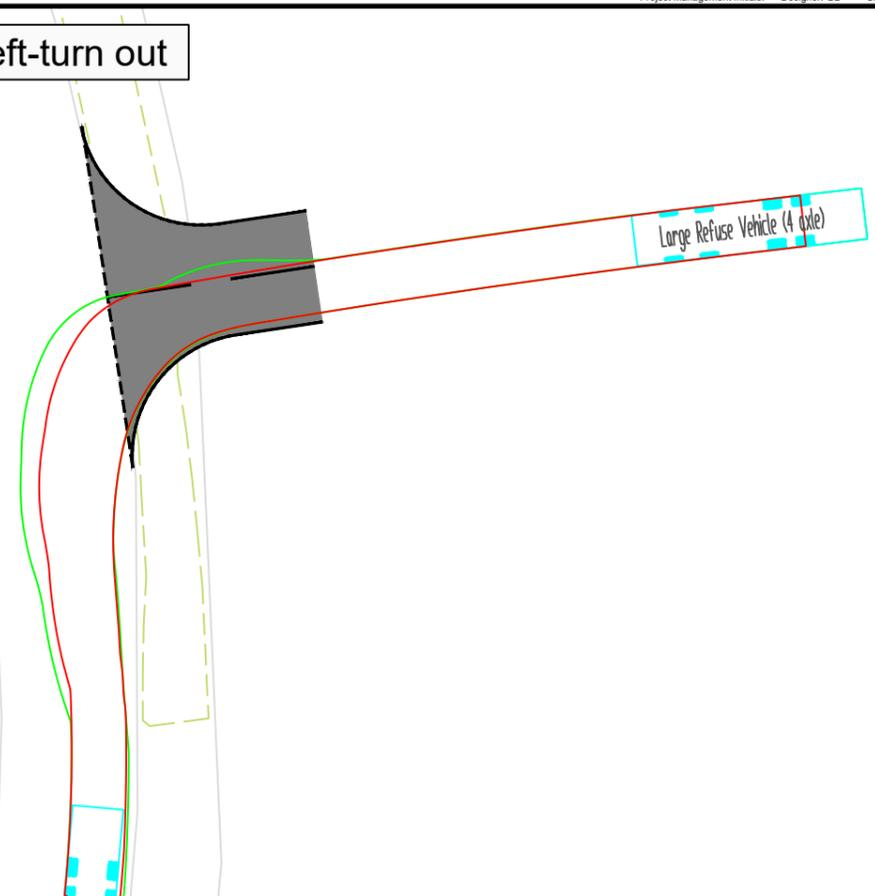

Refuse Vehicle - Right-turn in

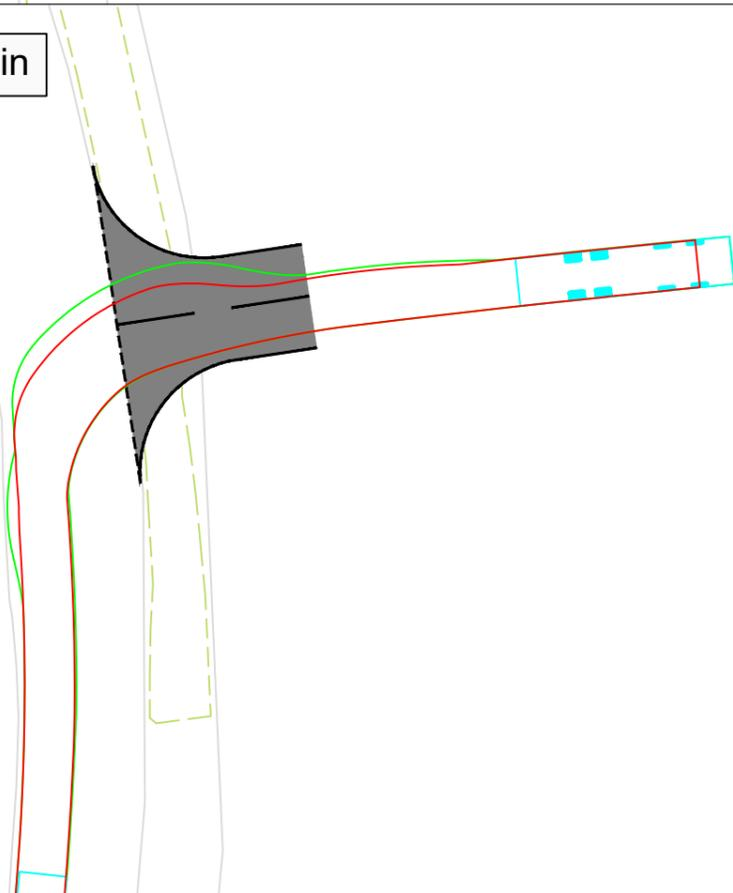

Refuse Vehicle- Right-turn out

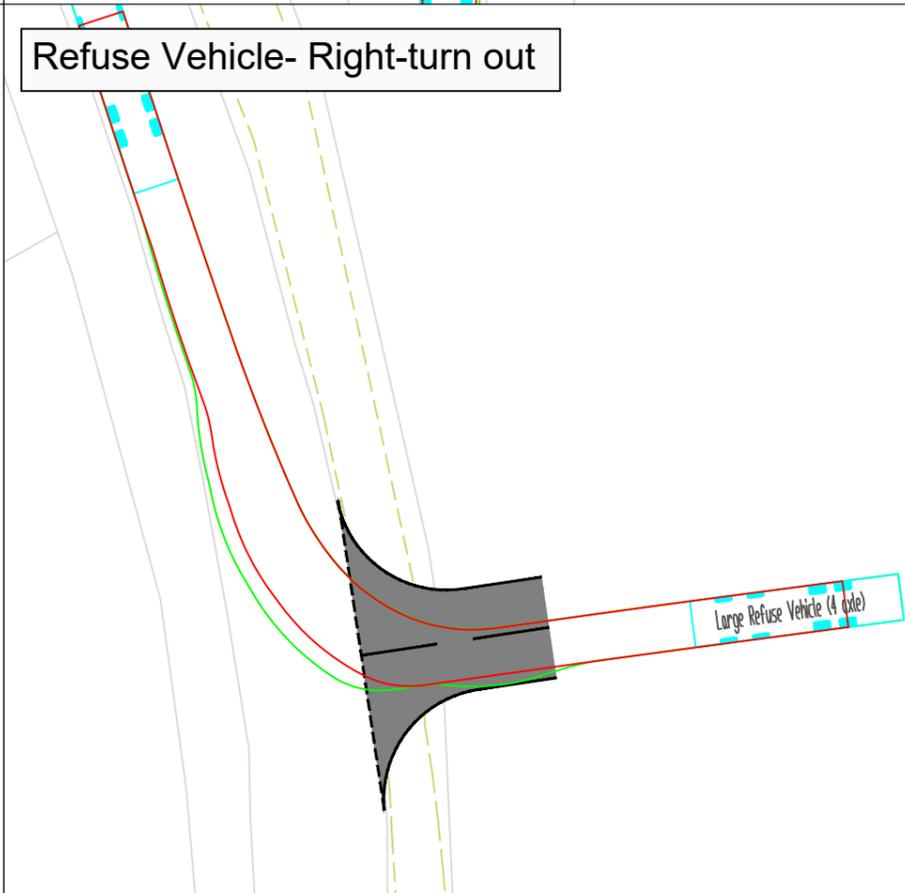

Large Refuse Vehicle (4 axle)	11.347m
Overall Length	11.347m
Overall Width	2.500m
Overall Body Height	3.751m
Min Body Ground Clearance	0.304m
Track Width	2.500m
Lock to lock time	6.00s
Wall to Wall Turning Radius	11.330m

Page 746

# Land at Bradbury Farm, Crick

Monmouthshire County Council Sites

Site Access Considerations - Alternative Access Location - SPA



---

Project:	<b>Monmouthshire County Council Sites</b>	Job No: <b>60720932</b>
Subject:	<b>Land At Oak Grove Farm, Portskewett</b>	
Prepared by:	<b>Ben Burton (Senior Consultant)</b>	Date: <b>15/05/2024</b>
Checked by:	<b>Spiro Panagi (Associate Director)</b>	Date: <b>16/05/2024</b>
Approved by:	<b>Spiro Panagi (Associate Director)</b>	Date: <b>16/05/2024</b>

---

## Appendices:

### Appendix A Site Access Considerations

#### 1. Introduction

This Technical Note (TN) has been prepared by AECOM to support the investigation into three sites for a potential Traveller settlement land use. The transport planning inputs will inform the assessment of the sites in the consideration for inclusion with the forthcoming Monmouthshire County Council (MCC) Replacement Local Development Plan (RLDP).

The three sites which have been identified for consideration are 'Land to rear of Langley Close, Magor', 'Land at Oak Grove Farm, Portskewett' and 'Land at Bradbury Farm, Crick'. It is understood that the scale of development for any potential site would be around 11 dwellings, to be comprised of temporary structures, potentially in the form of prefabricated units.

This TN discusses the transport considerations associated with 'Land at Oak Grove Farm, Portskewett' and includes the following:

- Consideration of local Planning Policy and this specific land use requirement;
- Baseline reporting on existing transport infrastructure for all modes;
- Forecasts of trip generation based on local knowledge, client forecasts and industry standard software TRICS;
- Description of development proposals and review against the Council parking and design standards; and
- Consideration of the proposed access and how that could appropriately continue to serve the proposed site.

#### 2. Planning Policy Context

The Monmouthshire County Council Local Development Plan (LDP) 2011-2021 was adopted on 27 February 2014, replacing the Monmouthshire Unitary Development Plan (UDP), to become the adopted development plan for the County.

Policy H8 '*Gypsy, Traveller and Travelling Showpeople Sites*' provides the framework for assessing proposals for Traveller sites, whether for permanent, transit or emergency use. Proposals for Traveller sites are assessed against the following criteria, whereby sites:

- *"Would enable the established need to be met at a location that is accessible to schools, shops and health care, by public transport, on foot or by cycle;*
- *Have a safe and convenient access to the highway network and will not cause traffic congestion or safety problems;*

- *Are of a suitable size to allow for the planned number of caravans, amenity blocks, a play area (for children on sites housing multiple families), the access road and include sufficient space for the parking and safe circulation of all vehicles associated with occupiers within the site curtilage;*
- *Do not occupy a prominent location and are consistent with LDP policies for protecting and enhancing character and distinctiveness of the landscape and environment. Where necessary the proposal will include mitigating measures to reduce the impact, and assimilate the proposal into its surroundings e.g. screening and landscaping;*
- *Avoid areas at high risk of flooding and proximity to uses with potential sources of pollution or emissions;*
- *Are of an appropriate scale to their location and do not have an unacceptable impact on the amenities of neighbouring land uses;*
- *Are served, or can be served, by adequate on-site services for water supply, power, drainage, sewage disposal and waste disposal (storage and collection), and for Travelling Showpeople that there is a level area for outdoor storage and maintenance of equipment.”*

In terms of transport and highways, the material considerations include accessibility to local facilities and communities, safe and convenient access to the highway network and an acceptable level of traffic impact, and the ability for vehicles to be safely accommodated by internal access routes and parking facilities.

### **3. Baseline Transport Conditions**

#### Local Highway Network

Access to the proposed site at Oak Grove Farm would be taken from the B4245. The B4245 is a single carriageway road that provides access to the A48, via a roundabout junction (referred to as Parkwall Roundabout) located approximately 600m to the northeast of the site. The B4245 provides access towards Caldicot which comprises the nearest urban centre to the site, approximately 2.5km to the southwest. The B4245 has a carriageway width of approximately 7.5m in the vicinity of the proposed site access. The B4245 has a posted speed limit of 60mph between Parkwall Roundabout and Leechpool, which lies approximately 150m to the northeast of the proposed site access. A section of the B4245, covering the extents of the existing properties located either side of Leechpool, is subject to an advised maximum speed of 40mph. The remainder of the B4245, to the southwest of the proposed site access, has a speed limit of 60mph.

The B4245 forms a priority T-Junction with Leechpool approximately 150m to the northeast of the proposed site access. Leechpool is a single track route that connects to Main Road, to the northeast of Portskewett. Leechpool provides access to a number of individual properties between the B4245 and Main Road and has an average carriageway width of approximately 4.0m.

Access to Junction 2 the M48 can be achieved via the A48, which connects to the B4245 at Parkwall Roundabout. The A48 continues northeast towards the A466 and Chepstow. The A466 provides a direct connection to the M48. To the west, the A48 routes from Parkwall Roundabout towards Newport and Junction 24 of the M4.

#### Walking and Cycling Environment

There is no walking or cycling provision on the B4245 in the locality of the proposed site. Approximately 1.5km to the southwest of the site, there is a footway provision on the southeastern side of the carriageway, on approach to Caldicott. To the north of the site along the A48, there is a footway provision on the north side of the carriageway for approximately 280m, to the west of Parkwall Roundabout. No active travel connections are present on the A48 heading north towards Chepstow.

There are no existing designated active travel routes located within close proximity of the proposed site. A set of Integrated Network Maps was submitted by MCC to the Welsh Government, which set out the Council's plans for improving active travel over the following 15 years. A future cycling route has been identified (ref. MCC-S24B) which passes very close to the north of the proposed site, as an off-road route that roughly follows the alignment of the A48 towards Chepstow.

Monmouthshire's Public Rights of Way (PRoW) mapping has been consulted to determine whether any existing routes pass through, or close by, to the site. Footpath ref. 376/4/1 lies to the southwest of the site, approximately 180m from the proposed access point, and extends between the B4245 and the A48 to the north.

National Cycle Network (NCN) Route 4 is available approximately 1.2km to the west of the site at the village of Crick. NCN Route 4 provides a long-distance route between Newport and Chepstow, as well as to destinations located further-afield.

### Public Transport Accessibility

The IHT's *Guidance for Providing for Public Transport in Developments*, published in 1999, suggests 400m as the 'acceptable' walking distance to a bus stop. The nearest bus stops to the proposed site are located adjacent to Parkwall Roundabout, approximately 900m from the proposed site access. **Table 3-1** provides a summary of the key bus services which are available from the bus stops at Parkwall Roundabout. Times and frequencies listed are reflective of the latest available timetable.

**Table 3-1: Summary of Local Bus Services**

Service	Route	Days	First Service	Last Service	Approximate Frequency
73	Newport – Chepstow	Mon-Fri	07:11	18:55	Hourly
		Saturday	07:56	16:54	120 minutes
	Chepstow - Newport	Mon-Fri	07:29	19:09	Hourly
		Saturday	10:16	18:16	120 minutes
74 / X74	Newport – Chepstow	Mon-Fri	07:14	19:44	Hourly
		Saturday	08:14	19:24	Hourly
	Chepstow - Newport	Mon-Fri	07:31	18:55	Hourly
		Saturday	08:35	19:40	Hourly

*Source: Bustimes.org (May 2024)*

In summary, **Table 3-1** demonstrates there is a reasonable availability of local bus services close to the site at Parkwall Roundabout. The lack of active travel provision along the B4245, between the proposed site access and Parkwall Roundabout, would raise highways safety concerns with regards to public transport accessibility for prospective residents of the development.

The proposed site lies between two railway stations, Caldicot and Chepstow. The nearest station to the site is Caldicot, which lies approximately 3.5km to the southwest. The main services available at Caldicot are Transport for Wales services between Maesteg and Cheltenham, via Cardiff, Newport and Bridgend. On average, a service is available every hour. Ticket machines are available at Caldicot Station, however there is no car or cycle parking facilities provided.

Local Facilities

There is a lack of local amenities within the locality of the proposed site. To the northeast, at Parkwall Roundabout, there is a food takeaway store, which lies adjacent to a golf course and leisure club. A car dealership and a care home are located within the settlement of Crick, approximately 1.4km to the west of the site. The majority of local amenities lie to the southwest of the site in Caldicot, including a supermarket, leisure centre, industrial employment facilities, doctors and multiple schools.

Highway Safety

Personal Injury Collision (PIC) data has been assessed using CrashMap for the most recently available 5-year period (2018-2022) in order to assess the road safety along the network in the vicinity of the site. There have been no PICs recorded in proximity to the site frontage. A 'slight' PIC was recorded approximately 900m to the southwest of the proposed site access. Three PICs have occurred at the Parkwall Roundabout, to the northeast of the site. Two of these were classified as 'serious' and appear to have happened on the same day. These are likely to be isolated incidents that do not suggest there to be an existing highways safety issue that could be exacerbated by the development.

**4. Potential Trip Generation & Parking Requirement**

It is understood that the scale of development for the site would be around 11 dwellings, to be comprised of temporary structures, potentially in the form of prefabricated units. The Trip Rate Information Computer System (TRICS) database has been used to calculate the proposed trip rate and subsequent trip generation for the proposed development. There are a limited number of Traveller sites available within TRICS, and as such, trip rates have been established using privately owned residential houses, with location types filtered to best represent the characteristics of the site at Oak Grove Farm. This is considered to represent a worst case scenario in terms of vehicular trip generation. The trip rates and resultant trip generation in terms of vehicle trips, for the traditional peak hours, are presented in **Table 4-1**.

**Table 4-1: Vehicle Trip Generation – Proposed Development (11 Dwellings)**

Time Period	Trip Rate			Trip Generation		
	Arrivals	Departures	Two-Way	Arrivals	Departures	Two-Way
AM Peak (08.00 – 09.00)	0.173	0.369	0.542	2	5	7
PM Peak (17.00 – 18.00)	0.381	0.188	0.569	5	3	8
Daily (07:00 – 19:00)	2.371	2.405	4.776	27	27	54

Based on the TRICS database, it is anticipated that the proposed development could generate up to seven two-way vehicles trips during the weekday AM peak hour and up to eight two-way vehicle trips during the weekday PM peak hour. There could be up to 54 two-way vehicle trips generated over the course of a day (07:00-19:00). In summary, the anticipated trip generation for the proposed development is low and is unlikely to have a material impact on the highway network.

MCC's Adopted Parking Standards Supplementary Planning Guidance (SPG) sets out the required parking levels for a range of development types. The SPG sets out four different parking zones within which to classify a specific site; this site is considered to be within 'Zone 3 – Countryside'. The SPG does not contain specific standards relating to Traveller sites, therefore the following requirements in relation to residential housing are considered to be the most comparable to the development at this stage:

**Table 4-2: Adopted Parking Standards – Residential**

Type	Residents	Visitors
Houses	1 space per bedroom (maximum requirement 3 spaces)	1 space per 5 units

At this stage, the proposed number of bedrooms per unit is unknown and therefore, exact parking requirements for the site would need to be defined once the development design has been sufficiently progressed. Based on the standards above, there would be a requirement for two visitor parking spaces on site. Car parking spaces will need to be designed in accordance with the specifications set out in the SPG. As an indication, this includes the requirement to provide standard parking space dimensions of 4.8m x 2.6m.

**5. Site Access Appraisal**

The below discussion appraises the proposed access points into the site and should be read in conjunction with the plans provided within **Appendix A**.

A preliminary junction design has been shown at the location of an existing gated field access, connecting to the B4245. At this stage, the junction has been designed with a 6m kerb radii and 5.5m access road carriageway width.

The existing visibility at the gated field access, where a new access junction is proposed, has been based on a 60mph speed limit. In accordance with the Design Manual for Roads and Bridges (DMRB), this equates to visibility requirements of 2.4m x 160m. Visibility has been demonstrated to be good in both directions at the proposed access location. This is aided by generally flat topography and low-lying vegetation identified as being within the visibility splay (and thus required to be kept below a height of 600mm). **Photos 5-1** and **5-2** have been included below to show the extents of visibility looking left and right at the location of the proposed access junction.

**Photo 5-1: Proposed Access Junction – Visibility (Looking Left)**



**Photo 5-2: Proposed Access Junction – Visibility (Looking Right)**



It was observed on site that there is an advisory speed limit of 40 mph to the east of the site. Therefore westbound traffic travelling along the B4245 and past the junction with Leechpool are advised of a maximum speed of 40 mph. This is also the case for eastbound vehicles going into the bend heading north towards Parkwall Roundabout and the A48. The location of these existing signs and restrictions are shown in the plans contained within **Appendix A**.

An extension, and formal adoption of the 40 mph maximum speed limit is considered beneficial for the proposed site, should it come forward. Whilst there is not an issue with vehicular visibility for 160 metres in each direction, it would be appropriate to lower speeds as a residential use is added or settlement extended west beyond Leechpool.

Vehicular stopping sight distance is comprised of a number of factors including road speed, driver reaction time and vehicle braking. The distance of 160 metres for the existing setting of 60 mph speeds shows how much distance is needed for a driver to see or be seen whilst travelling towards the location of the proposed site access or existing from the access. A speed limit of 40 mph would reduce this requirement to 90 metres, this is shown within **Appendix A** as an option for improvement. This does show that the change in speed could reduce the distance needed for drivers to see emerging vehicles or perhaps a future resident crossing the B4245.

Swept Path Analysis (SPA) has been conducted of the site access layout. This has been undertaken using a large car (5.0m length), delivery vehicle (8.0m length) and a large refuse vehicle (11.3m length). These represent the typical daily movements and servicing requirements for the site. No material issues have been identified with regards to access / egress of these vehicles. The use of the access by larger vehicles would require the full width of the access road (see refuse vehicle swept paths as an example), this is generally considered acceptable in street settings. However, it may be determined by the Highway Authority that due to the higher speed of road (outside of a street setting), vehicles should have sufficient room to turn into and out of the access without the need for stopping or giving way, to reduce the potential for collisions on the B4245. There is sufficient frontage and visibility to widen the site access if needed



and therefore this is considered to be a matter for discussion and clarification rather than a high risk issue. Should it be determined that a larger or more irregular vehicle could be required to deliver prefabricated units or static units, we can work with the team to assess the access for this.

## **6. Conclusions and Recommendations**

Overall, the existing gated field access is well located for vehicular visibility along the B4245. For the residential use proposed, considerations for this site should include the lack of sustainable transport facilities surrounding the site, with no footway connections available on the B4245. The site is positioned in a rural setting between local centres of Caldicot and Chepstow, and as such has very little supply of complimentary facilities / amenities in close proximity to the site. This could lead to the site being largely car-dominated in terms of incoming and outgoing trips, with little opportunity available for the uptake of active travel modes or use of sustainable transport in the form of buses or trains.

Appendix A

### Preliminary Access Junction Design

Carriageway width: 5.5m

Kerb radii: 6.0m

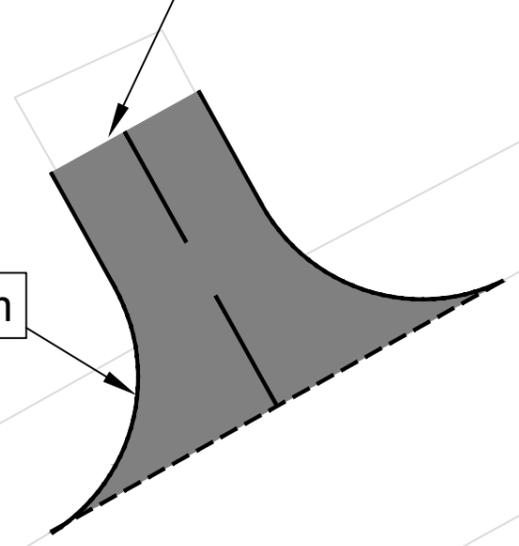

### Preliminary Access Junction Visibility Splays - 60mph

Visibility (looking left)



Visibility (looking right)



Objects / vegetation within the visibility splay limited to a maximum height of 0.6m.

51.5m

LB

B 4245

Lay-by  
B 4245



Key:

- 2.4m x 160m Visibility Splay (DMRB Guidance for 60mph)
- Area to be kept clear of obstructions

# Preliminary Access Junction Visibility Splays - 40mph (Observed Advisory Maximum Speed)

Objects / vegetation within the visibility splay limited to a maximum height of 0.6m.

Location of 40mph Speed Advisory



Location of 40mph Speed Advisory



51.5m

LB

B 4245

Lay-by



Key:

-  2.4m x 90m Visibility Splay (DMRB Guidance for 40mph)
-  Area to be kept clear of obstructions

Large Car - Left-turn in

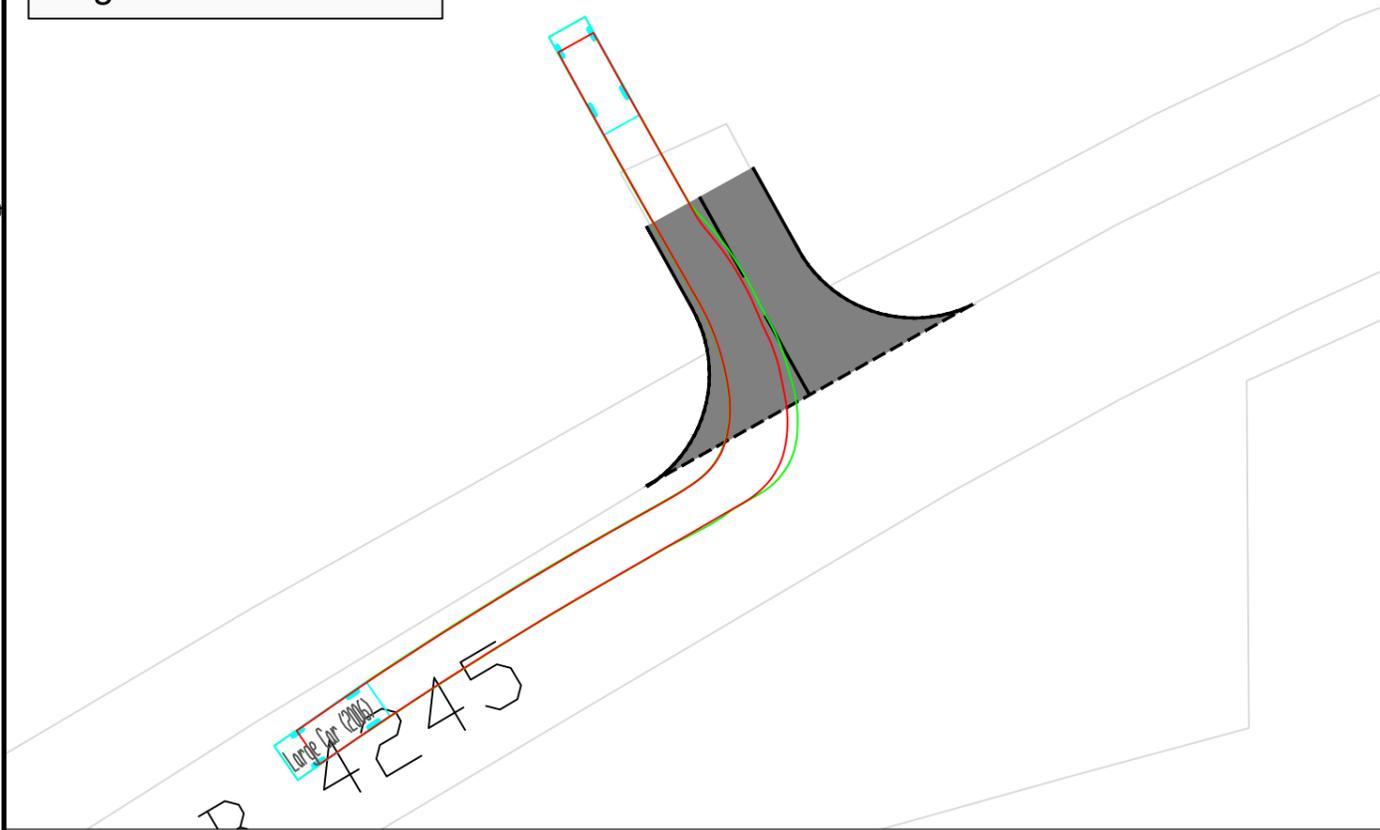

Large Car - Left-turn out

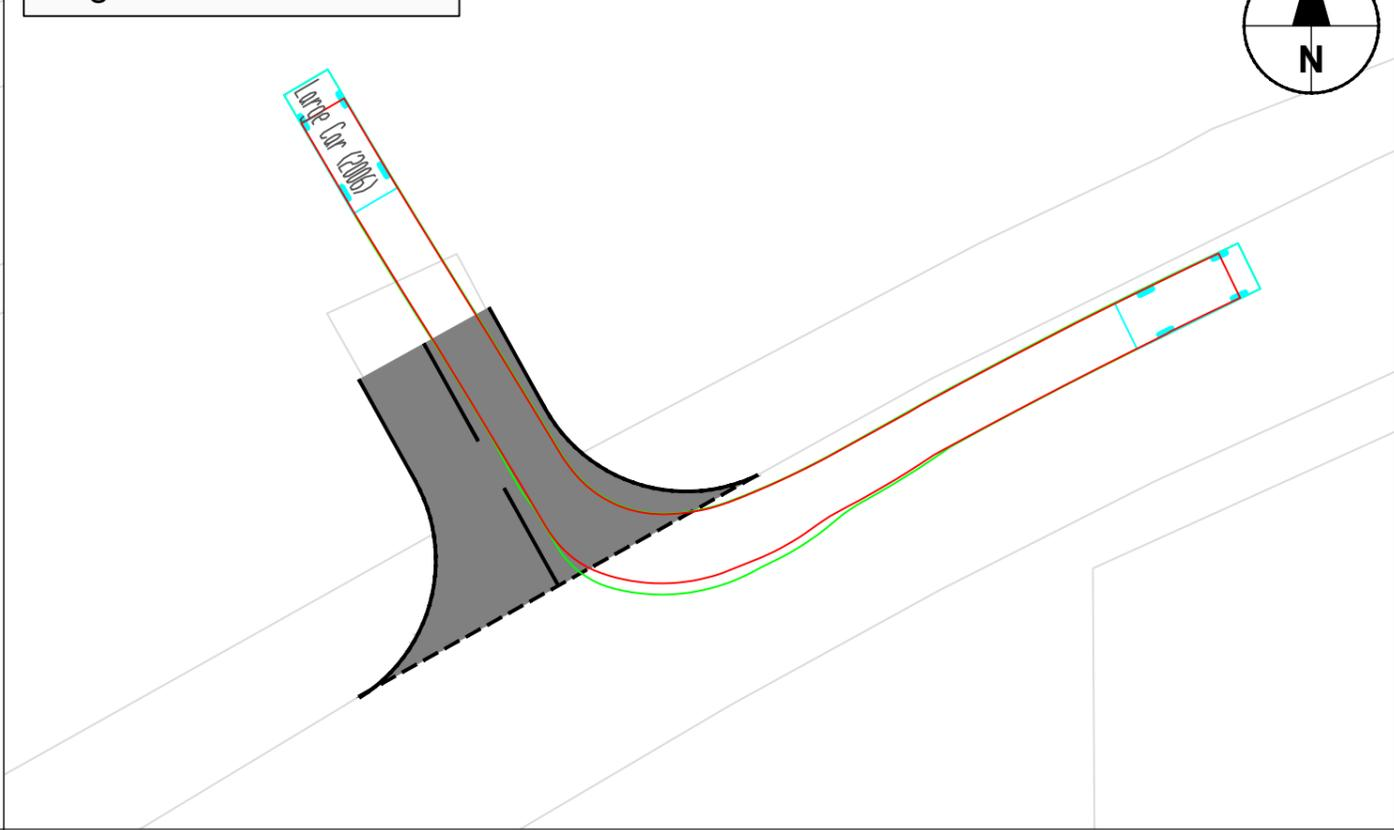

Large Car - Right-turn in

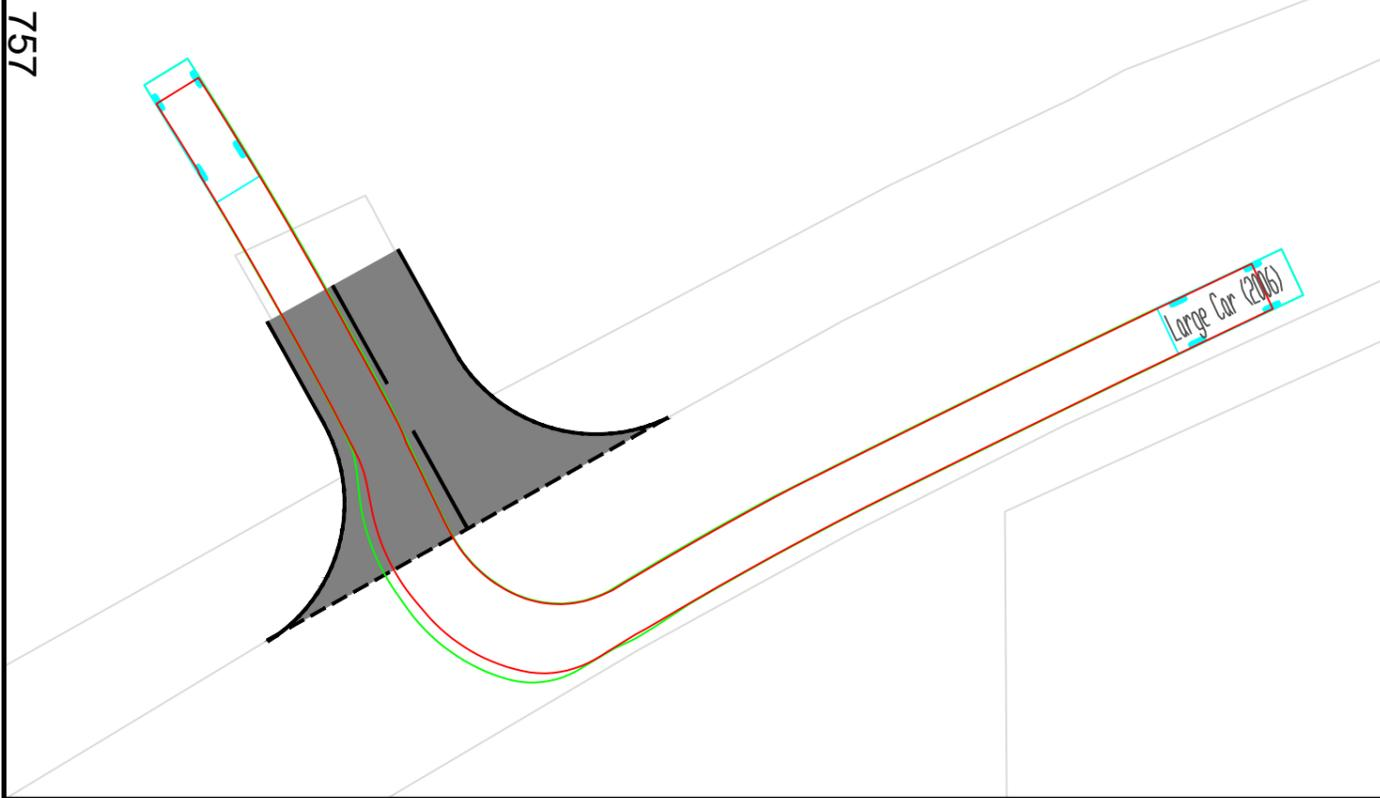

Large Car - Right-turn out

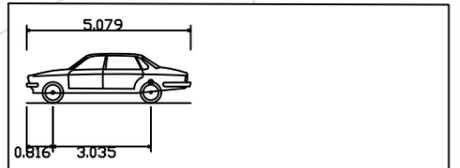
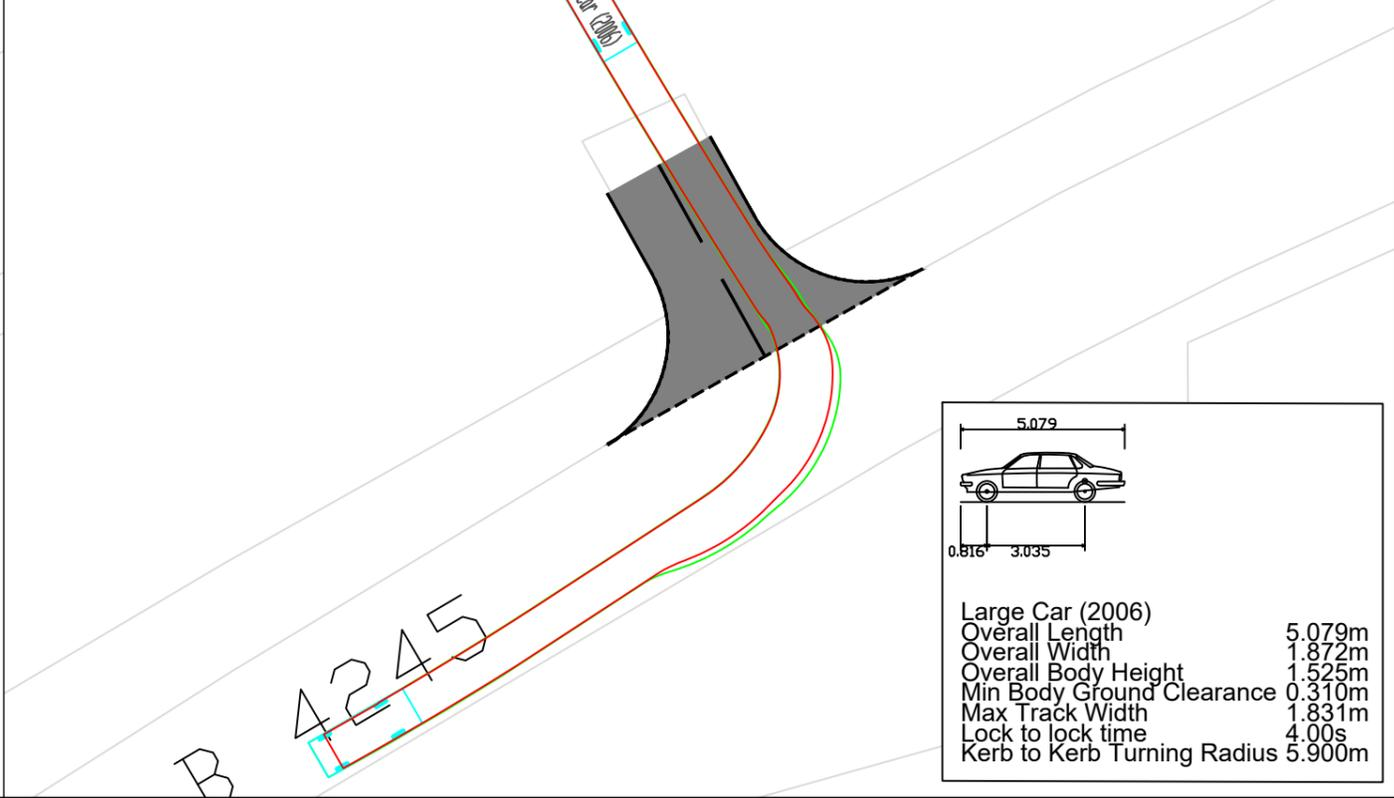

Large Car (2006)	
Overall Length	5.079m
Overall Width	1.872m
Overall Body Height	1.525m
Min Body Ground Clearance	0.310m
Max Track Width	1.831m
Lock to lock time	4.00s
Kerb to Kerb Turning Radius	5.900m

Page 757

# Land at Oak Grove Farm, Portskewett

Monmouthshire County Council Sites  
Site Access Considerations



Delivery Van - Left-turn in

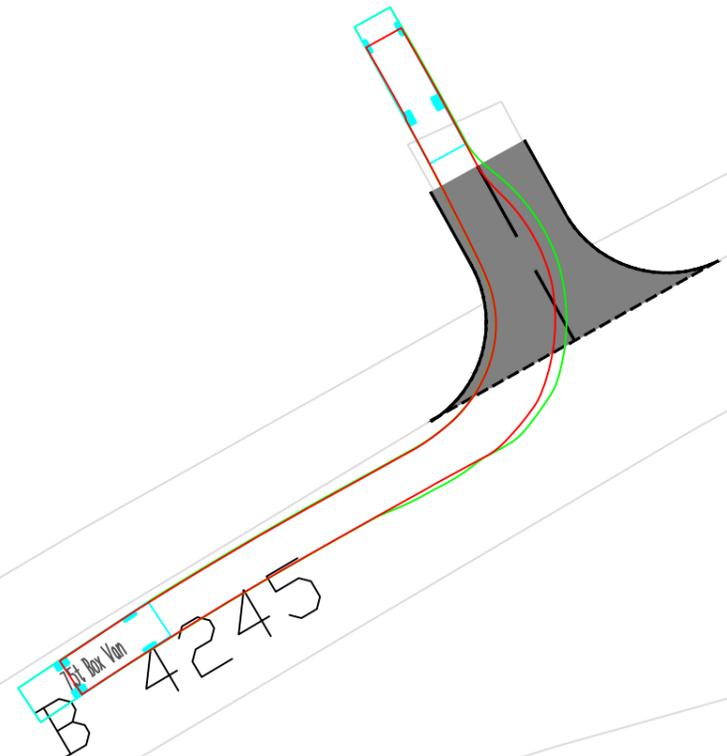

Delivery Van - Left-turn out

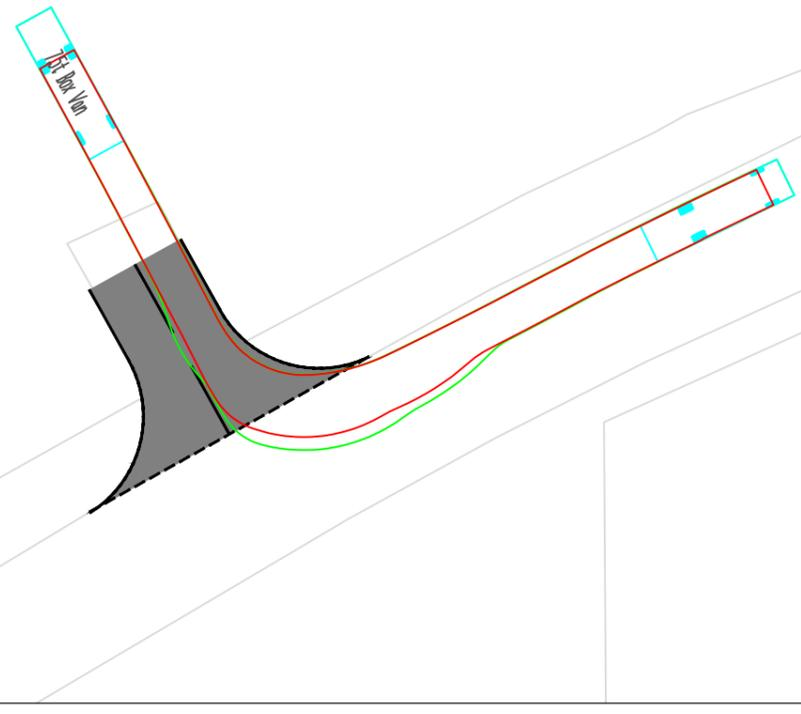

Delivery Van - Right-turn in

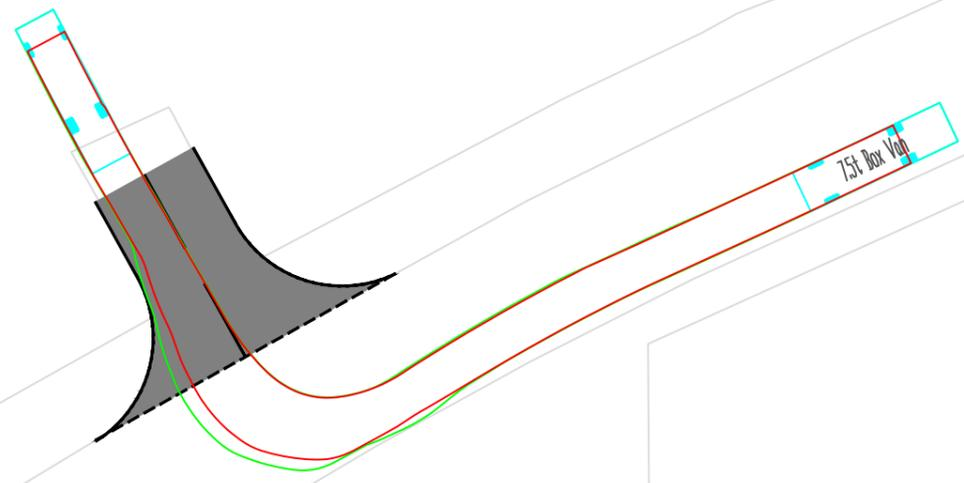

Delivery Van - Right-turn out

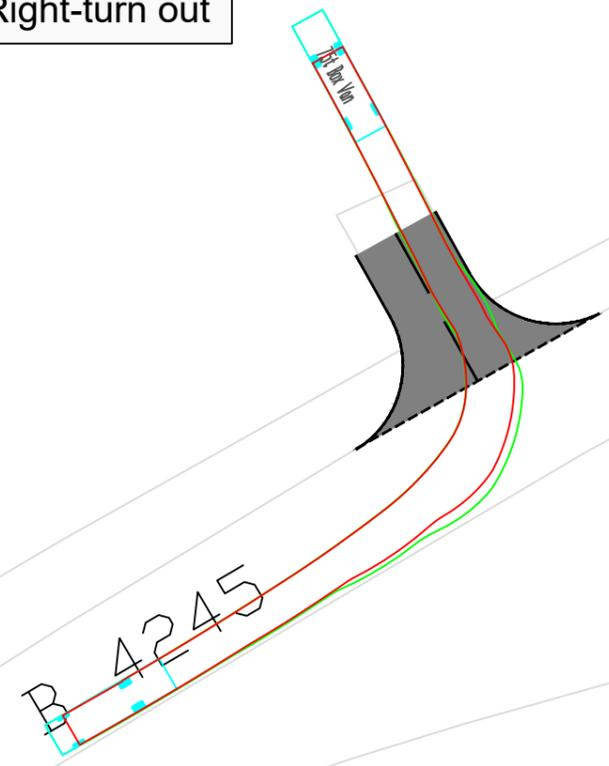

7.5t Box Van	
Overall Length	8.010m
Overall Width	2.100m
Overall Body Height	3.556m
Min Body Ground Clearance	0.351m
Track Width	2.064m
Lock to lock time	4.00s
Kerb to Kerb Turning Radius	7.400m

Page 758

# Land at Oak Grove Farm, Portskewett

Monmouthshire County Council Sites  
Site Access Considerations



Refuse Vehicle - Left-turn in

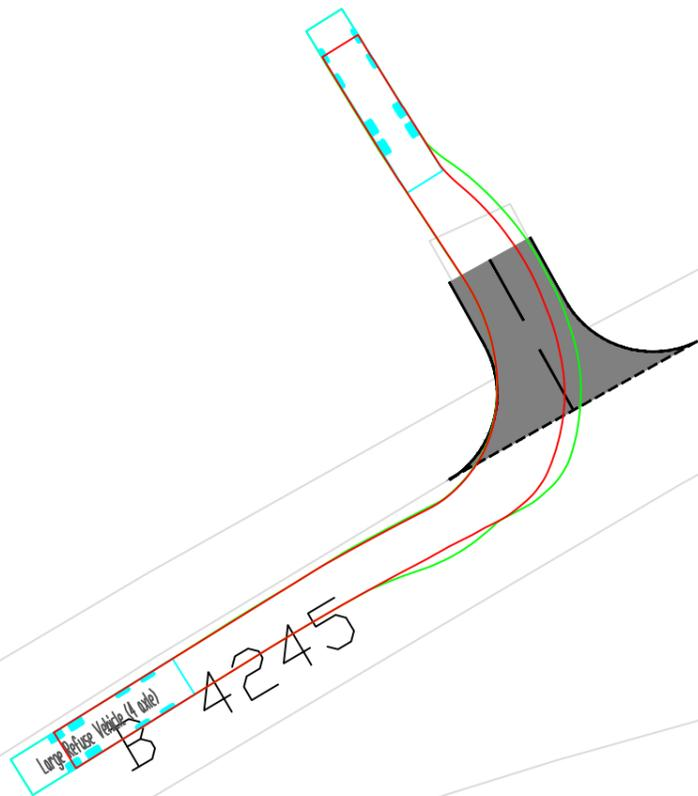

Refuse Vehicle - Left-turn out

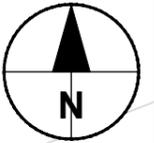
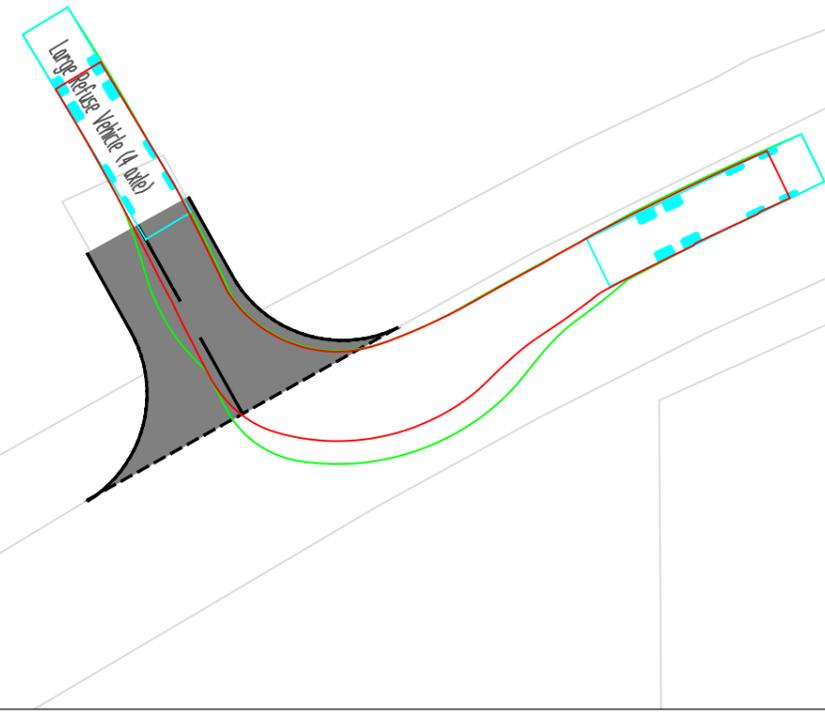

Refuse Vehicle - Right-turn in

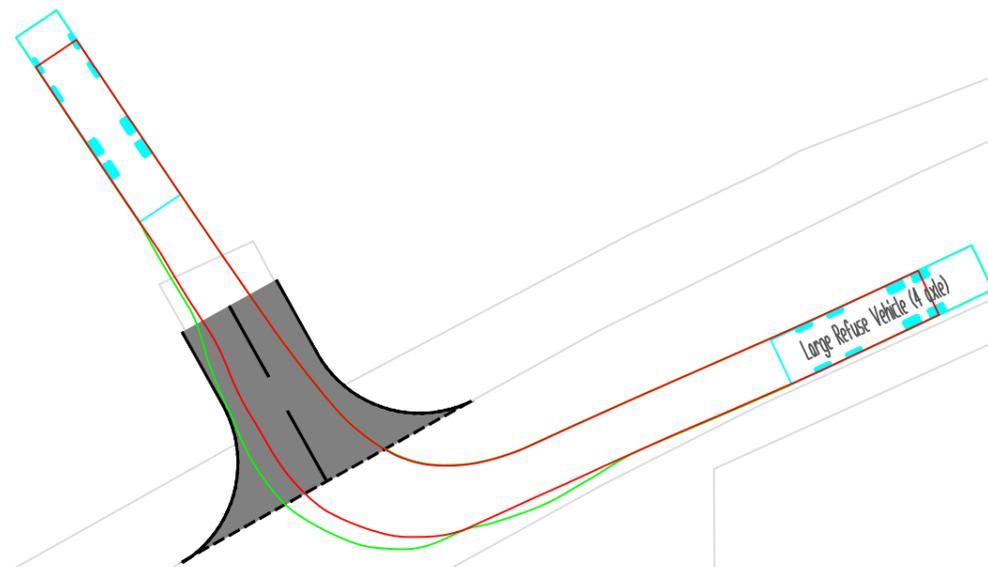

Refuse Vehicle- Right-turn out

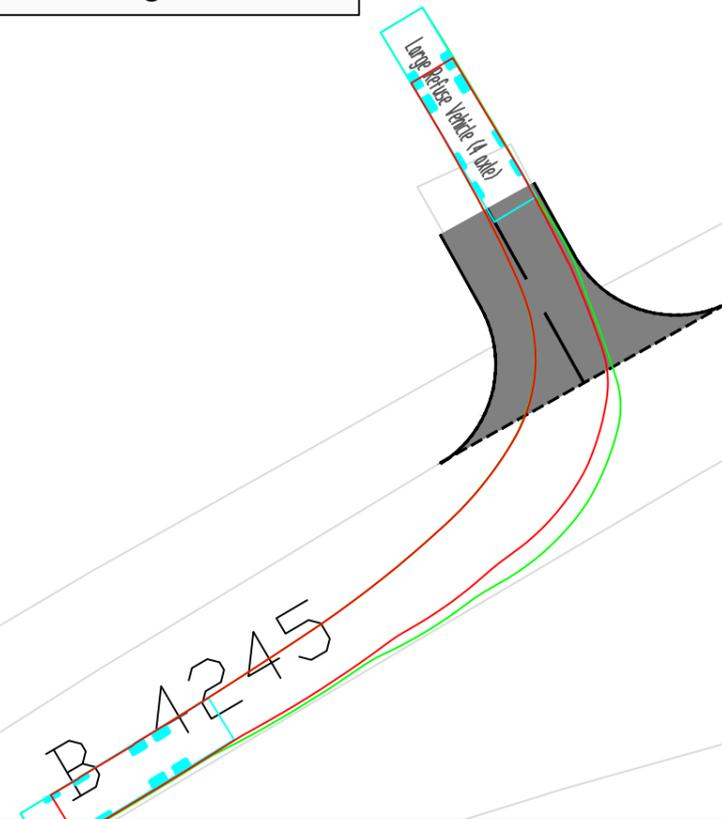

Large Refuse Vehicle (4 axle)	
Overall Length	11.347m
Overall Width	2.500m
Overall Body Height	3.751m
Min Body Ground Clearance	0.304m
Track Width	2.500m
Lock to lock time	6.00s
Wall to Wall Turning Radius	11.330m

This page is intentionally left blank



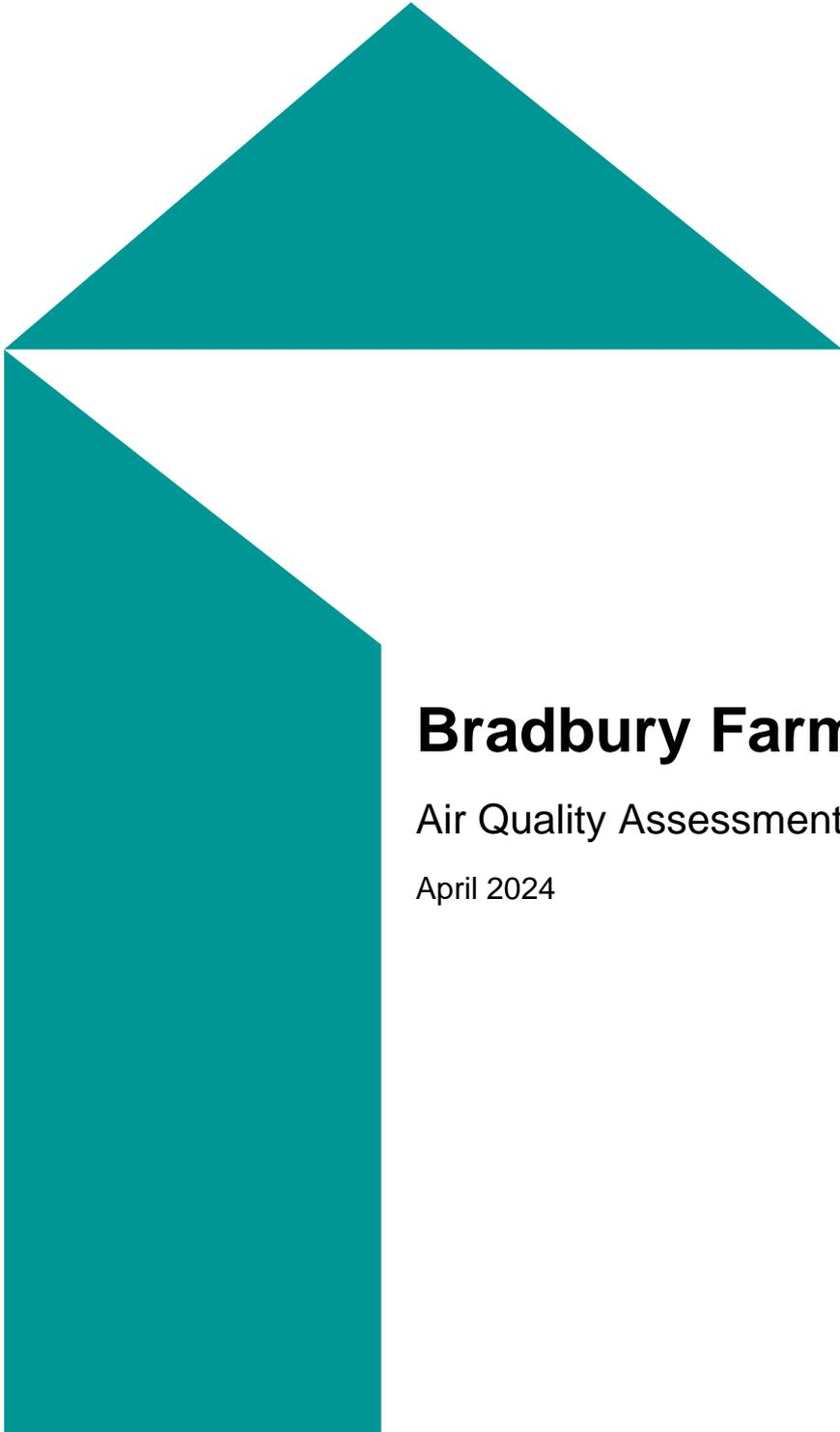

# Bradbury Farm

Air Quality Assessment

April 2024

This page left intentionally blank for pagination.

Mott MacDonald  
10 Livery Street  
Birmingham B3 2NU  
United Kingdom

T +44 (0)121 234 1500  
mottmac.com

# Bradbury Farm

## Air Quality Assessment

April 2024

# Issue and Revision Record

Revision	Date	Originator	Checker	Approver	Description
0	January 2024	T. Malik-Agrawal / H. Whalley	A. Lithgow-Dick	N. Cummins	First draft for client comment
1	April 2024	T. Malik-Agrawal / H. Whalley	A. Lithgow-Dick	N. Cummins	Client comments addressed

**Document reference:** 100115516 | AQ001 | P02 | 100115516

**Information class:** Standard

This document is issued for the party which commissioned it and for specific purposes connected with the above-captioned project only. It should not be relied upon by any other party or used for any other purpose.

We accept no responsibility for the consequences of this document being relied upon by any other party, or being used for any other purpose, or containing any error or omission which is due to an error or omission in data supplied to us by other parties.

This document contains confidential information and proprietary intellectual property. It should not be shown to other parties without consent from us and from the party which commissioned it.

# Contents

<b>1</b>	<b>Introduction</b>	<b>1</b>
1.1	Overview	1
1.2	Proposed development location	1
<b>2</b>	<b>Legislation and policy</b>	<b>3</b>
2.1	Overview	3
2.2	Legislation	3
2.3	Policy	4
<b>3</b>	<b>Methodology</b>	<b>10</b>
3.1	Overview	10
3.2	Traffic data used in assessment	10
3.3	Model selection	10
3.4	Emissions data	10
3.5	Receptors	10
3.6	NO <sub>x</sub> to NO <sub>2</sub> relationship	11
3.7	Predicted 1-Hour concentrations	12
3.8	Assessment criteria	12
3.9	Assumptions and limitations	12
<b>4</b>	<b>Baseline</b>	<b>13</b>
4.1	Overview	13
4.2	Local authority review and assessment	13
4.3	Defra projected background concentrations	19
4.4	Pollution Climate Model (PCM)	19
4.5	Local emission sources	20
4.6	Summary	20
4.7	Mitigation	21
<b>5</b>	<b>Potential Impacts</b>	<b>22</b>
5.1	Overview	22
5.2	Site suitability	22
5.3	Mitigation	22
<b>6</b>	<b>Conclusions</b>	<b>23</b>

## Tables

Table 2.1: Relevant air quality objectives and limit values	8
Table 2.2: Locations where the air quality objectives apply	9
Table 3.1: Traffic data	10
Table 3.2: Modelled receptor	11
Table 4.1: Automatic monitoring results	14
Table 4.2: Diffusion tube monitoring results	17
Table 4.3: Defra projected background concentrations of NO <sub>x</sub> , NO <sub>2</sub> , PM <sub>10</sub> , PM <sub>2.5</sub> , for proposed development in 2024 (µg/m <sup>3</sup> )	19
Table 4.4: Defra projected background concentrations of NO <sub>x</sub> , NO <sub>2</sub> , PM <sub>10</sub> , PM <sub>2.5</sub> , for proposed development in 2019 (µg/m <sup>3</sup> )	19
Table 5.1: Predicted impact on NO <sub>2</sub> concentrations at the Proposed Gypsy & Travellers Site and sensitive receptor	22

## Figures

Figure 1.1: Site location	2
Figure 3.1: Location of modelled receptor	11
Figure 4.1: Automatic monitoring location	15
Figure 4.2: Diffusion tube locations	18
Figure 4.3: Nearby PCM links	20

# 1 Introduction

## 1.1 Overview

Mott MacDonald has been appointed by Monmouthshire County Council (MCC) to provide an air quality report as part of MCC's Gypsy and Traveller Accommodation Assessment (GTAA) identification study for the Bradbury Farm site in Crick, Monmouthshire (hereafter referred to as "the proposed Gypsy and Traveller site") one of the three council-owned identified sites for potential development. The proposed Gypsy and Travellers site is understood to comprise the construction of up to six pitches that will include parking and a collective utility block with access gained via St Bride's Road which runs along the eastern boundary of the site.

This report provides a summary of existing air quality information around the proposed Gypsy & Travellers Site and an assessment of the suitability of the site for the proposed users. The energy demand for the proposed Gypsy & Travellers Site is unknown at the moment, but it is expected to be of a typical bricks and mortar dwelling, with electricity and water supply at the minimum. It is expected that this would not extend to gas supply.

In order to assess site suitability, we have undertaken two types of assessment. Firstly, a qualitative review of local and national air quality monitoring data and secondly, a quantitative Design Manual for Roads and Bridges (DMRB) calculation spreadsheet assessment, using the latest Department for Transport (DfT) traffic count data from 2022 for the M48. In addition, the assessment considers the suitability of air quality at the proposed development for the introduction of additional receptors in accordance with Environmental Protection UK (EPUK) and Institute of Air Quality Management (IAQM) guidance .by considering the location of the Proposed Gypsy & Travellers Site in relation to existing emission sources. No site-specific monitoring has been undertaken due to existing local authority and national monitoring data already being available.

No assessment of the potential impacts associated with the construction of the Proposed Gypsy & Travellers Site, such as nuisance, loss of amenity and health impacts caused by construction dust, have been undertaken at this stage. Construction impacts are likely to be temporary and can be controlled using appropriate mitigation in a Construction Environmental Management Plan (CEMP). An assessment of construction impacts is therefore not required at the feasibility stage.

## 1.2 Proposed development location

The Proposed Gypsy & Travellers Site is located to the west of Leechpool, Monmouthshire. The Proposed Gypsy & Travellers Site is bound by fields to the south. Crick Road bounds the Proposed Gypsy & Travellers Site to the west, with residential property to the north, adjacent to M48. An undulating bank of trees separate the Proposed Gypsy & Travellers Site from the motorway, which is approximately 12 metres (m) at its narrowest point. The Proposed Gypsy & Travellers Site is located within the administrative area of MCC. The Proposed Gypsy & Travellers Site is also located 4.5km to the east of the boundary of Newport City Council (NCC), therefore has also been taken into consideration. The location of the Proposed Gypsy & Travellers Site is presented in Figure 1.1.

Figure 1.1: Site location

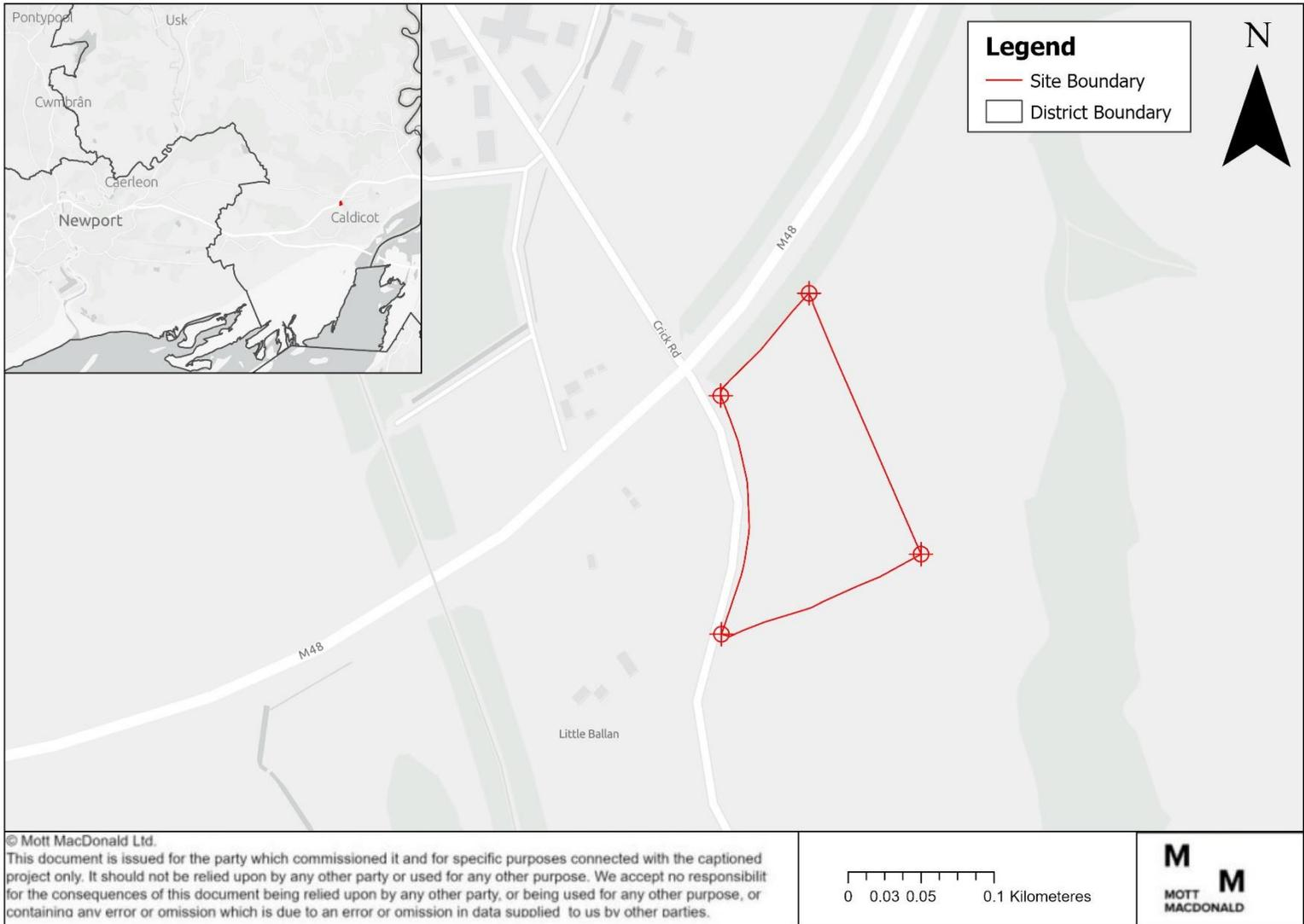

Page 768



## 2 Legislation and policy

### 2.1 Overview

This section summarises the relevant international and national legislation, policy and planning guidance in relation to air quality. In addition, local planning policy guidance has been reviewed in order to identify air quality policy implications related to the Proposed Gypsy & Travellers Site.

### 2.2 Legislation

#### 2.2.1 Wales

The European Union Directive on ambient air quality and cleaner air for Europe (2008/50/EC)<sup>1</sup> sets legally binding limits for pollutant concentrations. This directive was made law in the Wales through The Air Quality Standards (Wales) Regulations 2010<sup>2</sup> (amended by The Air Quality Standards (Wales) (Amendment) (EU Exit) Regulations 2019<sup>3</sup> and the Environment (Miscellaneous Amendments) (EU Exit) Regulations 2020<sup>4</sup>).

This Directive defines limit values and times by which they are to be achieved for the purpose of protecting human health and the environment by avoiding, reducing or preventing harmful concentrations of air pollutants. The Limit Values within the Directive are intended to apply everywhere with the exception of:

- any locations situated within areas where members of the public do not have access and there is no fixed habitation
- in accordance with Article 2(1), on factory premises or at industrial installations to which all relevant provisions concerning health and safety at work apply
- on the carriageway of roads, and
- on the central reservations of roads except where there is normally pedestrian access to the central reservation.

Part IV of the Environment Act 1995<sup>5</sup> (as amended in Schedule 11 of the Environment Act 2021<sup>6</sup>) requires that every local authority shall carry out a review of air quality within its designated area, including predictions of likely future air quality. The air quality objectives specifically for use by local authorities in carrying out their air quality management duties are set out in The Air Quality (Wales) Regulations 2000<sup>7</sup> and The Air Quality (Wales) (Amendment) Regulations 2002<sup>8</sup>. In most cases, the air quality objectives are set at the same pollutant concentrations as the limit values transposed into UK law although compliance dates differ.

As part of the review of air quality, the local authority must assess whether air quality objectives are being achieved or are likely to be achieved within the relevant periods and identify the relevant sources of emissions it considers responsible for the failure to achieve the objectives. Any parts of a local authority's area where the objectives are not being achieved or are not likely

---

<sup>1</sup> The European Parliament and the Council of the European Union (2008) Directive 2008/50/EC of the European Parliament and of the Council

<sup>2</sup> Statutory Instrument (2010) The Air Quality Standards (Wales) Regulations

<sup>3</sup> Statutory Instrument (2019) The Air Quality Standards (Wales) (Amendment) (EU Exit) Regulations

<sup>4</sup> Statutory Instrument (2020) Environment (Miscellaneous Amendments) (EU Exit) Regulations 2020, No. 1313.

<sup>5</sup> Department for Environment Food and Rural Affairs. (2009). Part IV of the Environment Act 1995 Local Air Quality Management Policy Guidance (PG09). London: Defra.

<sup>6</sup> Statutory Instrument. (2021) Chapter 30, Schedule 11 Local Air Quality Management Framework of Environment Act 2021

<sup>7</sup> Statutory Instrument (2000) The Air Quality (Wales) Regulations, No. 1940 (W.138).

<sup>8</sup> Statutory Instrument (2002) The Air Quality (Amendment) (Wales) Regulations, No. 3182 (W.298).

to be achieved within the relevant period must be identified and declared as an Air Quality Management Area (AQMA). Once such a declaration has been made, local authorities are under a duty to prepare an Action Plan which sets out measures to pursue the achievement of the air quality objectives within the AQMA.

The Environment Act 1995 requires the UK Government to produce a national Air Quality Strategy (AQS). The AQS establishes the UK framework for air quality improvements. Measures agreed at the national and international level are the foundations on which the strategy is based. The first AQS, first adopted in 1997<sup>9</sup> and its subsequent iterations, have now been superseded as of the 14th January 2019 with the Clean Air Strategy 2019 (CAS).<sup>10</sup>

The CAS does not set legally binding objectives, the CAS instead has targets for reducing total UK emissions of NO<sub>x</sub> and fine particulate matter (PM<sub>2.5</sub>) from sectors such as road transport, domestic sources and construction plant (non-road mobile machinery (NRMM)).

Further to this, the UK Government has produced a draft AQS revision in 2023. This revision replaces the 2007 strategy and compliments the CAS. The 2023 revision sets out the actions the government expects local authorities in England to take in support of achieving the Government's long-term air quality goals, including their two new long-term PM<sub>2.5</sub> targets. The AQS does not mention local authorities in Wales and as such the long-term PM<sub>2.5</sub> targets currently only apply to England. Therefore, the revised draft AQS and new targets are not applicable to this project at the time of writing. However, the Welsh Government have published their own 'Clean Air Plan' for Wales in 2019 to provide a framework and actions for air quality improvements within Wales.

## 2.3 Policy

### 2.3.1 Air Quality Strategy

Part IV of the Environment Act 1995<sup>11</sup> (as amended in Schedule 11 of the Environment Act 2021<sup>12</sup>) places a duty on the Secretary of State for the Environment to develop, implement and maintain an Air Quality Strategy with the aim of reducing atmospheric emissions and improving air quality. The Air Quality Strategy provides air quality standards and objectives for key air pollutants, which are designed to protect human health and the environment and sets out how the different sectors: industry, transport and local government, can contribute to achieving the air quality objectives.

The first Air Quality Strategy for England, Scotland, Wales and Northern Ireland was published in 2007<sup>13</sup> and has now been superseded as of the 14th January 2019 with the Clean Air Strategy 2019 (CAS)<sup>14</sup>. Although the CAS has been developed at a UK level, the Welsh Government have also published their own 'Clean Air Plan' for Wales in 2019 to provide a framework and actions for air quality improvements within Wales. The CAS has targets for reducing total UK emissions of nitrogen oxides (NO<sub>x</sub>) and fine particulate matter (PM<sub>2.5</sub>) from sectors such as road transport, domestic sources and construction plant (non-road mobile machinery or NRMM).

---

<sup>9</sup> Department for Environment Food and Rural Affairs. (March 1997), 'The United Kingdom National Air Quality Strategy', Cm 3587, Department for Environment Food and Rural Affairs.

<sup>10</sup> Department for Environment Food and Rural Affairs. (January 2019), 'The Clean Air Strategy'

<sup>11</sup> Department for Environment Food and Rural Affairs (2003) Part IV of the Environment Act 1995 Local Air Quality Management.

<sup>12</sup> Statutory Instrument. (2021) Chapter 30, Schedule 11 Local Air Quality Management Framework of Environment Act 2021.

<sup>13</sup> Defra (2007) The Air Quality Strategy for England, Scotland, Wales and Northern Ireland

<sup>14</sup> Defra (2019) The Clean Air Strategy

## 2.3.2 Statutory nuisance

Section 79(1)(d) of the Environmental Protection Act 1990<sup>15</sup> defines one type of 'statutory nuisance' as "any dust, steam, smell or other effluvia arising on industrial, trade or business premises and being prejudicial to health or a nuisance". Where a local authority is satisfied that a statutory nuisance exists, or is likely to occur or recur, it must serve an abatement notice. Failure to comply with an abatement notice is an offence. 'Best practicable means' is a widely used defence by operators, if used to prevent or to counteract the effects of the nuisance.

## 2.3.3 National policy

### 2.3.3.1 Planning Policy

The current air quality planning policies for the Welsh Government are set out in Planning Policy Wales Edition 11 (February 2021)<sup>16</sup>. Those relevant to air quality are:

- Chapter 3 'Strategic and Spatial Choices', which highlights the importance of promoting healthier places through the planning system. This includes enabling opportunities for outdoor activities, good design in planning to minimise exposure to poor air quality, reduction of health inequalities and making positive contributions to environmental protection and improvement, including air quality.
- Chapter 4 'Active and Social Places', which states that the Welsh Government is committed to supporting modal shift from private cars to walking, cycling and public transport and that local authorities must adopt an integrated approach to traffic management, also considering wider planning objectives such as improvement in air quality.
- Chapter 5 'Productive and Enterprising Places' details that planning authorities should take into account the need to minimise impacts on local communities and the natural environment and that any minerals proposals must set out criteria to prevent adverse impacts upon these receptors.
- Chapter 6 'Distinctive and Natural Places' states that development plan strategies, policies and development proposals should look to the long-term protection and enhancement of the built and natural environment in order to achieve Wales's wellbeing goals. This includes considering effects of development proposals on air quality with the aim to reduce population exposure to air pollution in Wales.

Planning Policy Wales (PPW) is supplemented by a series of topic-based Technical Advice Notes (TANs). TAN 18 Transport details the importance of good air quality, and states: "*well designed and implemented traffic management can help secure planning objectives...[by]... reducing...local air pollution...*".

In June 2017, the Welsh Government set out further provisions in Policy guidance PG(W)(17)<sup>17</sup>, which adopts five ways of working set out in the Well-being of Future Generations (Wales) Act 2015<sup>18</sup> with the intention to improve the economic, social, environmental and cultural well-being of Wales in accordance with the sustainable development principles. The five ways of working are:

- "*looking to the long term so we do not compromise the ability of future generations to meet their own needs;*

---

<sup>15</sup> Parliament of the United Kingdom. (1990), 'Environmental Protection Act', Chapter 43. Queen's Printer of Acts of Parliament.

<sup>16</sup> Welsh Government. (2021) Planning Policy Wales. Edition 11. [online] Available at: [https://gov.wales/sites/default/files/publications/2021-02/planning-policy-wales-edition-11\\_0.pdf](https://gov.wales/sites/default/files/publications/2021-02/planning-policy-wales-edition-11_0.pdf)

<sup>17</sup> Welsh Government (2017) Local air quality management in Wales. Part of the Environment Act 1995. Policy guidance PG(W)(17)

<sup>18</sup> Welsh Government (2015) Well-being of Future Generations (Wales) Act 2015.

- *taking an integrated approach;*
- *involving a diversity of the population in the decisions affecting them;*
- *working with others in a collaborative way to find shared sustainable solutions; and*
- *acting to prevent problems from occurring or getting worse.”*

Welsh local authorities are expected to follow these ways of working when carrying out their LAQM duties.

The Welsh Government published The Wales Transport Strategy<sup>19</sup> in 2021, which sets out the Government’s main transport development aims and how these will be achieved. The strategy contains long-term health and environmental outcomes for transport in Wales; “*Chapter 03. Well-being ambitions*” aims to improve air quality *through “encouraging more active travel, greater use of public transport and low emissions vehicles, and by creating closer links between land-use planning and transport in line with our commitments in the Clean Air Plan for Wales.”*

### 2.3.3.2 Air Quality Plan for Nitrogen Dioxide in the UK

The latest plan for tackling roadside NO<sub>2</sub> concentrations was published by Defra in July 2017 and details the government’s plan to reduce NO<sub>2</sub> concentrations within statutory limits within the shortest possible time<sup>20</sup>. Within this plan, several named local authorities with exceedances of the NO<sub>2</sub> limit values are required to undertake a local assessment to consider the best options to achieve compliance with this limit value. The Welsh Government published a supplemental plan<sup>21</sup> to the UK plan in November 2018 to provide additional information of which measures would ensure compliance with the limit values for NO<sub>2</sub> within Wales in the shortest possible time.

The Proposed Gypsy & Travellers Site is within the South Wales Zone (UK0041), which is covered by a zone-specific Air Quality Plan<sup>22</sup>. Baseline model projections of South Wales from 2017 to 2030 in the Air Quality Plan shows that maximum modelled annual mean NO<sub>2</sub> concentration is predicted to drop to 42µg/m<sup>3</sup> by 2025. No specific measure is Monmouthshire County Council or Newport City Council.

## 2.3.4 Local policy

### 2.3.4.1 Monmouthshire County Council Adopted Local Development Plan

The Monmouthshire Adopted Local Plan<sup>23</sup> was adopted in 2011 and set out frameworks for development across Monmouthshire up to 2021. The main policy of relevance is Policy EP1 ‘Amenity and Environmental Protection’, which states that:

- Development, including proposals for new buildings, extensions to existing buildings and advertisements, should have regard to the privacy, amenity and health of occupiers of neighbouring properties.
- Development proposals that would cause or result in an unacceptable risk /harm to local amenity, health, the character /quality of the countryside or interests of nature conservation,

---

<sup>19</sup> Welsh Assembly Government (2008). One Wales: Connecting the Nation. The Wales Transport Strategy. [online] <https://gov.wales/sites/default/files/publications/2017-09/wales-transport-strategy.pdf>

<sup>20</sup> Defra (2017) UK plan for tackling roadside nitrogen dioxide concentrations: Detailed Plan [online] Available at: [https://assets.publishing.service.gov.uk/government/uploads/system/uploads/attachment\\_data/file/633270/air-quality-plan-detail.pdf](https://assets.publishing.service.gov.uk/government/uploads/system/uploads/attachment_data/file/633270/air-quality-plan-detail.pdf)

<sup>21</sup> Welsh Government. 2018. Welsh Government supplemental plan to the UK plan for tackling roadside nitrogen dioxide concentrations 2017: Tackling roadside nitrogen dioxide concentrations in Wales. [online] Available at: <https://gov.wales/sites/default/files/publications/2019-04/tackling-roadside-nitrogen-dioxide-concentrations-in-wales.pdf>

<sup>22</sup> Defra (2017) Air Quality Plan for tackling roadside nitrogen dioxide concentrations in North Wales (UK0042). [online] [https://uk-air.defra.gov.uk/assets/documents/no2ten/2017-zone-plans/AQplans\\_UK0041.pdf](https://uk-air.defra.gov.uk/assets/documents/no2ten/2017-zone-plans/AQplans_UK0041.pdf)

<sup>23</sup> Monmouthshire County Council (2014) Adopted Local Development Plan (2011-2021)

landscape or built heritage importance due to the following will not be permitted, unless it can be demonstrated that measures can be taken to overcome any significant risk:

- Air pollution;
- Light pollution;
- Noise pollution;
- Water pollution;
- Contamination;
- Land instability;
- Or any identified risk to public health or safety

#### 2.3.4.2 Replacement Local Development Plan Overview

The Replacement Local Development Plan (RLDP)<sup>24</sup> is in progress by the MCC to improve the Local Development Plan mentioned in Section 2.3.2. for implementation up to 2033. The two main RLDP points of relevance are Objective 17 'Climate and Nature Emergency' which states that:

- To strive to limit the increase in global temperatures to 1.5°C, supporting carbon reduction through a variety of adaptation measures including facilitating resilient ecosystems and nature recovery, the use of renewable energy, net zero ready homes, the design and location of new development, encouraging balanced job and population growth to reduce out-commuting, the provision of broadband connectivity to reduce the need to travel, the provision of ultra-low emission vehicle charging infrastructure to reduce emissions and improve air quality, and the provision of quality Green Infrastructure.

And Strategic Policy S4 'Climate Change' Point VII which states:

- Providing ultra-low emission vehicle charging infrastructure to reduce emissions and improve air quality.

#### 2.3.4.3 Newport City Council Local Development Plan

The Newport Adopted Local Plan<sup>25</sup> was adopted in 2015 and set out frameworks for development across Newport up to 2026. The main policies of relevance are Policy SP14 'Transport Proposals' Point IX which states:

- Transport proposals will be supported where they result in other environmental improvements including air quality, noise reductions, sustainable drainage and enhanced biodiversity.

And Policy GP2 'General Development Principles – General Amenity' which states that:

- Development will be permitted where, as applicable:
  - there will not be a significant adverse effect on local amenity, including in terms of noise, disturbance, privacy, overbearing, light, odours and air quality;
  - the proposed use and form of development will not be detrimental to the visual amenities of nearby occupiers or the character or appearance of the surrounding area;
  - the proposal seeks to design out the opportunity for crime and anti-social behaviour;
  - the proposal promotes inclusive design both for the built development and access within and around the development;

---

<sup>24</sup> Monmouthshire County Council (2023) Replacement Local Development Plan

<sup>25</sup> Monmouthshire County Council (2014) Adopted Local Development Plan (2011-2021)

- adequate amenity for future occupiers.

And Policy GP4 ‘General Development Principles – Highway and Accessibility’ which states that:

- Development proposals should:
  - provide appropriate access for pedestrians, cyclists and public transport in accordance with national guidance;
  - be accessible by a choice of means of transport;
  - be designed to avoid or reduce transport severance, noise and air pollution; iv) make adequate provision for car parking and cycle storage;
  - provide suitable and safe access arrangements;
  - design and build new roads within private development in accordance with the highway authority’s design guide and relevant national guidance;
  - ensure that development would not be detrimental to highway or pedestrian safety or result in traffic generation exceeding the capacity of the highway network.

And Policy GP7 ‘General Development Principles – Environmental Protection and Public Health’ which states that:

- Development will not be permitted which would cause or result in unacceptable harm to health because of land contamination, dust, instability or subsidence, air, heat, noise or light pollution, flooding, water pollution, or any other identified risk to environment, local amenity or public health and safety.

### 2.3.5 Summary

Air quality objectives and limit values are summarised in Table 2.1.

**Table 2.1: Relevant air quality objectives and limit values**

Pollutant	Averaging Period	Concentration	Allowance	Attainment Date	
				Air Quality Objectives	Limit Values
Nitrogen dioxide (NO <sub>2</sub> )	Annual	40 µg/m <sup>3</sup>	-	31 December 2005 <sup>(a)</sup>	1 January 2010 <sup>(c)</sup>
	1 Hour	200 µg/m <sup>3</sup>	18	31 December 2005 <sup>(a)</sup>	1 January 2010 <sup>(c)</sup>
Particulates (PM <sub>10</sub> )	Annual	40 µg/m <sup>3</sup>	-	31 December 2004 <sup>(a)</sup>	1 January 2005 <sup>(c)</sup>
	24 Hour	50 µg/m <sup>3</sup>	35	31 December 2004 <sup>(a)</sup>	1 January 2005 <sup>(c)</sup>
Fine particulates (PM <sub>2.5</sub> ) <sup>(d)</sup>	Annual	20 µg/m <sup>3</sup>	-	-	1 January 2020 <sup>(c)</sup>
		25 µg/m <sup>3</sup>	-	2020 <sup>(b)</sup>	-

Notes: <sup>(a)</sup> Air Quality (Wales) Regulations 2000 as amended  
<sup>(b)</sup> Air Quality Strategy 2007  
<sup>(c)</sup> EU Directive 2008/50/EEC on ambient air quality and cleaner air for Europe, as transposed into UK Law  
<sup>(d)</sup> As the Air Quality Strategy 2007 and EU Directive 2008/50/EC have a different numerical standard for PM<sub>2.5</sub>, the more stringent standard of 20µg/m<sup>3</sup> has been adopted for this assessment.

Table 2.2 provides details of where the respective objectives should and should not apply and therefore the types of receptors that are relevant to the assessment of air quality.

**Table 2.2: Locations where the air quality objectives apply**

<b>Averaging Period</b>	<b>Objectives should apply at:</b>	<b>Objectives should not apply at:</b>
Annual	All locations where members of the public might be regularly exposed. Building façades of residential properties, schools, hospitals, care homes, etc.	Building façades of offices or other places of work where members of the public do not have regular access. Hotels, unless people live there as their permanent residence. Gardens of residential properties. Kerbside sites (as opposed to locations at the building façade), or any other location where public exposure is expected to be short-term.
24-Hour	All locations where the annual mean objective would apply, together with hotels. Gardens of residential properties.	Kerbside sites (as opposed to locations at the building façade), or any other location where public exposure is expected to be short-term.
1-Hour	All locations where the annual mean and 24-hour mean objectives apply. Kerbside sites (for example, pavements of busy shopping streets). Those parts of car parks, bus stations and railway stations, etc., which are not fully enclosed, where members of the public might reasonably be expected to spend one hour or more. Any outdoor locations where members of the public might reasonably be expected to spend one hour or longer.	Kerbside sites where the public would not be expected to have regular access.

Source: Defra TG22<sup>26</sup>.

<sup>26</sup> Department for Environment, Food and Rural Affairs and Devolved Administrations (August 2022). Local Air Quality Management – Technical Guidance LAQM.TG22

## 3 Methodology

### 3.1 Overview

This Section provides the approach taken to consider the suitability of the Proposed Gypsy & Travellers Site, key elements of which include model choice, traffic data, emission factors and dealing with uncertainty.

### 3.2 Traffic data used in assessment

The Gypsy & Travellers Site has the potential to affect air quality by increasing traffic by increasing the number of vehicles on the road network and by affecting existing traffic through the introduction of more people visiting the site.

The traffic data used in this assessment was obtained from the Department for Transport (DfT)<sup>27</sup>, providing data on vehicle flows in annual average daily traffic flows (AADT), including heavy duty vehicle<sup>28</sup> (HDV) percentages and speeds (km/hr). The 2022 data has been used as the base year and for model verification as it is considered to be most representative. The data has been presented in Table 3.1.

**Table 3.1: Traffic data**

Road ID	Location Reference	AADT	%HDV	Speed (kph)
1	M4	104164	9.7	112
2	M48 Crick	14148	12.3	112

### 3.3 Model selection

The DMRB calculation spreadsheet formulas have been used for this assessment in conjunction with the latest Local Air Quality Management (LAQM) tools provided by Defra. Only NO<sub>2</sub> has been considered within this assessment as ambient concentrations of PM<sub>10</sub> and PM<sub>2.5</sub> are well below the respective objectives (as indicated in Section 4.4.2). The emission factors for PM<sub>10</sub> and PM<sub>2.5</sub> are lower than NO<sub>2</sub>, therefore, the change in concentrations and associated impact magnitude associated with PM<sub>10</sub> and PM<sub>2.5</sub>, as a result of the Gypsy & Travellers Site would be less than assessed for NO<sub>2</sub>.

### 3.4 Emissions data

Pollutant emissions from vehicles have been estimated using vehicle emission factors calculated from Defra's Emission Factor Toolkit (EFT), based on traffic flows, speeds and vehicle emission factors. The latest EFT (Version 12.0.1, released December 2023)<sup>29</sup> has been used within this assessment.

### 3.5 Receptors

The air quality objectives only apply in locations of relevant exposure, as presented within Table 2.2: . There are no plans currently available highlighting the exact location of the facades of the

<sup>27</sup> Road traffic statistics - Manual count point: 74081 (dft.gov.uk)

<sup>28</sup> A HDV is any vehicle with a gross weight greater than 3.5 tonnes. This typically includes heavy goods vehicles (HGVs), buses and coaches

<sup>29</sup> [https://laqm.defra.gov.uk/wp-content/uploads/2023/12/EFT2023\\_v12.0.1.xlsb](https://laqm.defra.gov.uk/wp-content/uploads/2023/12/EFT2023_v12.0.1.xlsb)



proposed structures within the Gypsy & Travellers Site. A Receptors point has therefore been chosen at the boundary of the Gypsy & Travellers Site to represent a worst-case location. The chosen receptor is presented within Table 3.2 and displayed in Figure 3.1.

**Table 3.2: Modelled receptor**

Receptor ID	National Grid reference		Height (m)
	X	Y	
R1	348931	189904	1.5

**Figure 3.1: Location of modelled receptor**

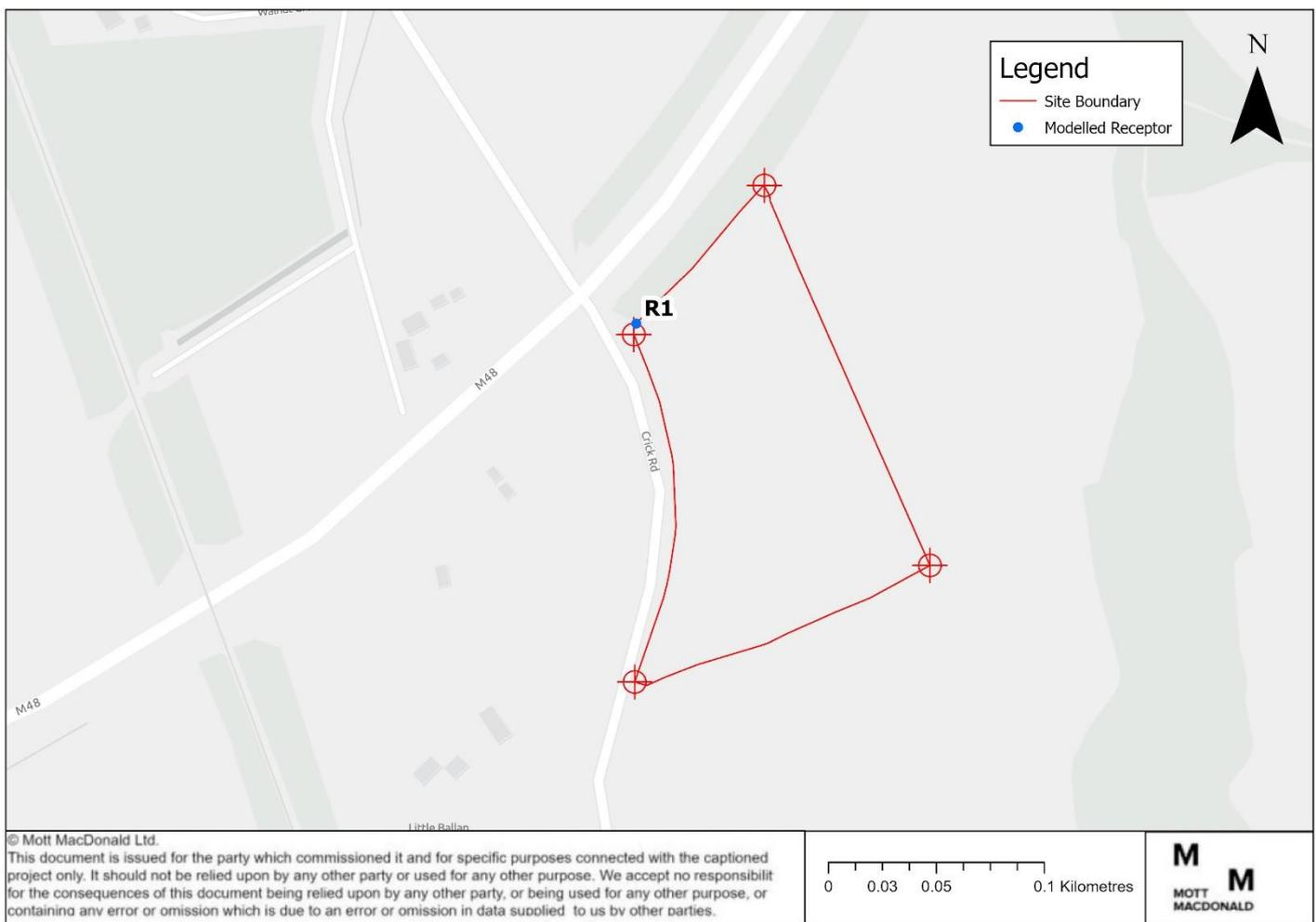

### 3.6 NO<sub>x</sub> to NO<sub>2</sub> relationship

The DMRB calculation spreadsheet formulas used for this assessment provides outputs for NO<sub>x</sub> which need to be converted to NO<sub>2</sub> to allow comparison with the relevant air quality objectives. Defra provides a spreadsheet-based method<sup>30</sup> for calculating annual mean NO<sub>x</sub> to NO<sub>2</sub>

<sup>30</sup> Department for Environment Food and Rural Affairs (2021). Local Air Quality Management (LAQM) website, available at: <https://laqm.defra.gov.uk/air-quality/air-quality-assessment/nox-to-no2-calculator/>

conversions. This method has been used within the assessment and is the most appropriate way of determining NO<sub>2</sub> concentrations from road NO<sub>x</sub> contributions.

### 3.7 Predicted 1-Hour concentrations

Guidance from Defra's TG22 indicates that the hourly NO<sub>2</sub> air quality objective of 200µg/m<sup>3</sup> (not to be exceeded more than 18 times per year) is unlikely to be exceeded at roadside locations where the annual mean concentration is less than 60µg/m<sup>3</sup>. Results presented in Section 5 will be screened using this criteria.

### 3.8 Assessment criteria

No formal significance criteria has been used for this assessment, results will however be compared against Table 2.1.

### 3.9 Assumptions and limitations

The air quality modelling predictions are associated with an inherent level of uncertainty, primarily a result of:

- Uncertainties with traffic data
- Uncertainties with vehicle emission predictions
- Uncertainties with background air quality maps

Model uncertainty can be addressed through the process of model verification. Model verification is a two-step process. Firstly, modelled concentrations are compared with monitored concentrations to identify any disparity. Where disparity occurs, the model inputs are revisited to identify any potential errors or opportunity for improvement of the model. Where disparity remains following the first step, model results can be adjusted to account for systematic bias.

A requirement of model verification is air quality monitoring data in a location that is similar, in terms of road traffic and layout, to the dispersion site and where traffic data for a proposed development is available. In this instance, although NCC do undertake air quality monitoring adjacent to the M4 there was uncertainty of their true locations which could not be clarified by a desk-based study. On this basis, it has not been possible to carry out a quantitative model verification with the process described above. For the purposes of this assessment, NO<sub>2</sub> model outputs, presented in Section 5.2, have been increased by a factor of 2. A factor which is considered to be considered highly conservative based on previous project experience and is therefore considered to be robust.

## 4 Baseline

### 4.1 Overview

Information on air quality in the UK can be obtained from a variety of sources including local authorities, national network monitoring sites and other published sources. For the purposes of this assessment, data has been obtained from Defra<sup>31</sup> and MCC<sup>32</sup>.

The most recent full year of monitoring data available for the monitoring sites operated by MCC and Defra is 2021 and 2022 respectively. The monitoring data for 2021 however is unlikely to be representative of 'normal' conditions at the monitoring sites, due to the effects associated with the coronavirus (Covid-19) pandemic during those years when England was subject to periods of lockdowns and the influences this had on traffic. Therefore, the data for 2021 is presented for reference only and the most recent year with representative data for MCC and Defra is 2019 and 2022 respectively.

### 4.2 Local authority review and assessment

#### 4.2.1 Air Quality Management Areas

MCC has declared two AQMAs in its administrative area, Usk AQMA and Chepstow AQMS, both located over 5km away from the Proposed Gypsy & Travellers Site. NCC has declared over 13 AQMAs in its administrative area. The closest AQMA in NCC is located approximately 14km away from the site. All AQMAs located in MCC and NCC are in urban locations and therefore not representative of our site. The proposed development will not impact any of the AQMAs and therefore are not considered further.

#### 4.2.2 Local authority monitoring

##### 4.2.2.1 Automatic monitoring

MCC undertook automatic monitoring at one site within its administrative area in 2022. The monitoring site is located approximately 12km northeast to the Proposed Gypsy & Travellers Site but is not considered to be representative of the site as it is located near the urban area of Chepstow. However, the NCC undertook automatic monitoring at two sites within its administrative area in 2021. Both AN1 and AN2 are located 10km to the west of the Proposed Gypsy & Travellers Site. Both are considered to be more representative due to their location next to the M4 motorway. AN1 measured NO<sub>2</sub>, PM<sub>10</sub>, and PM<sub>2.5</sub> and AN2 measured NO<sub>2</sub> only, as seen in Table 4.1. However, The Annual Progress Report (2022) for NCC is missing annual mean NO<sub>2</sub> automatic data for both sites, therefore the automatic monitoring that is undertaken at a monitoring station that is part of the Automatic Urban and Rural Network (AURN) operated by Defra has been used. The location of the AURN monitoring site (UKA00380) is in a similar location to AN1. The monitoring station is located over 10km to the west of the Proposed Gypsy & Travellers Site. The locations can be seen in Figure 4.1.

---

<sup>31</sup> Department for Environment Food and Rural Affairs. Air Quality Information Resource (Air) Website. Available at: <http://uk-air.defra.gov.uk/>

<sup>32</sup> Monmouthshire County Council (2022) Air Quality Annual Status Report

**Table 4.1: Automatic monitoring results**

Site ID	Site Type	Council Name	Approx. distance from the proposed development (km)	National Grid Reference		Pollutant	Annual mean NO <sub>2</sub> concentration (µg/m <sup>3</sup> )/ Exceedances of Short-Term Objective (-) * or Annual mean PM <sub>10</sub> concentration (µg/m <sup>3</sup> )/ Exceedances of Short-Term Objective (-) #				
				X	Y		2018	2019	2020	2021	2022
UKA00380 / AN1	Urban Background	NCC	16	332418	189603	NO <sub>2</sub>	15 (-)	35 (-)	33 (-)	21 (-)	21 (-)
UKA00380 / AN1	Urban Background	NCC	16	332418	189603	PM <sub>10</sub>	14 (0)	15 (0)	13 (0)	12 (0)	-
UKA00380 / AN1	Urban Background	NCC	16	332418	189603	PM <sub>2.5</sub>	8 (0)	10 (0)	8 (0)	7 (0)	-

Source: Newport City Council, LAQM Annual Progress Report (2022) Local Authority Details - Defra, UK  
Note: Dash (-): no monitoring data available.

Page 780

**Figure 4.1: Automatic monitoring location**

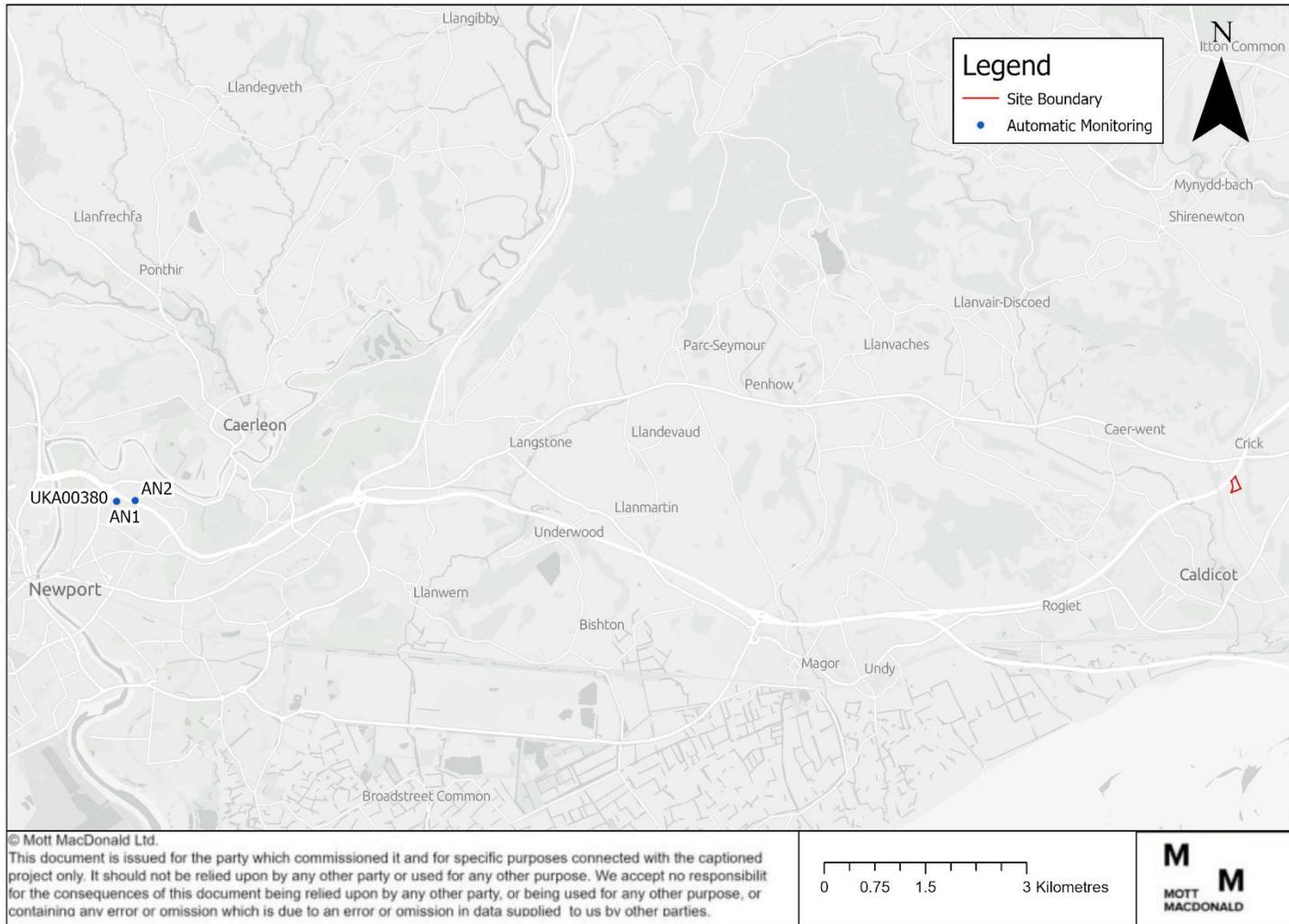

Note: Although not data is presented within Table 4.1 relating to Site AN2, it has been added to the figure for reference only

#### 4.2.2.2 Diffusion tube monitoring

MCC undertook in NO<sub>2</sub> diffusion tube monitoring at 49 tubes across their administrative boundary in 2022. However, these are located on the roadside within the urban area of Chepstow, therefore not representative of our site. However, NCC undertook in NO<sub>2</sub> diffusion tube monitoring at 81 tubes across their administrative boundary in 2021. The closest diffusion tubes have been selected as shown in Table 4.2. These are considered to be representative of the site due to their location near the M4 motorway. The location of these diffusion tubes is shown in Figure 4.2. The results show that there were no exceedances at any of the monitoring sites between 2018 and 2021 except for NCC21d, NCC23e which had exceedances in 2018, 2019, and 2020.

**Table 4.2: Diffusion tube monitoring results**

Site ID	Site Type	Council Name	Approx. distance from the proposed development (km)	National Grid Reference		Annual mean NO <sub>2</sub> concentration (µg/m <sup>3</sup> )				
				X	Y	2018	2019	2020	2021	2022
NCC16a	Roadside	NCC	16.5	332320	189703	28.2	27.5	22.6	21.8	-
NCC21d, NCC23e	-	NCC	16.5	332690	189615	<b><u>54.6</u></b>	<b><u>48.5</u></b>	<b><u>46.7</u></b>	34.7	-
NCC37, NCC38, NCC39	Background	NCC	16.5	332499	189569	18.6	18.5	14.4	13.5	-
NCC31	Façade	NCC	14	334951	189237	36.7	35.6	29.9	26.6	-
1S1	-	NCC	16.5	332320	189702	-	-	-	20.6	-
1S2	Roadside	NCC	16.5	332312	189702	-	-	-	18.9	-

Source: Newport City Council, LAQM Annual Progress Report (2022)

Note: Dash (-): no monitoring data available.  
Exceedances shown in bold and underlined

Figure 4.2: Diffusion tube locations

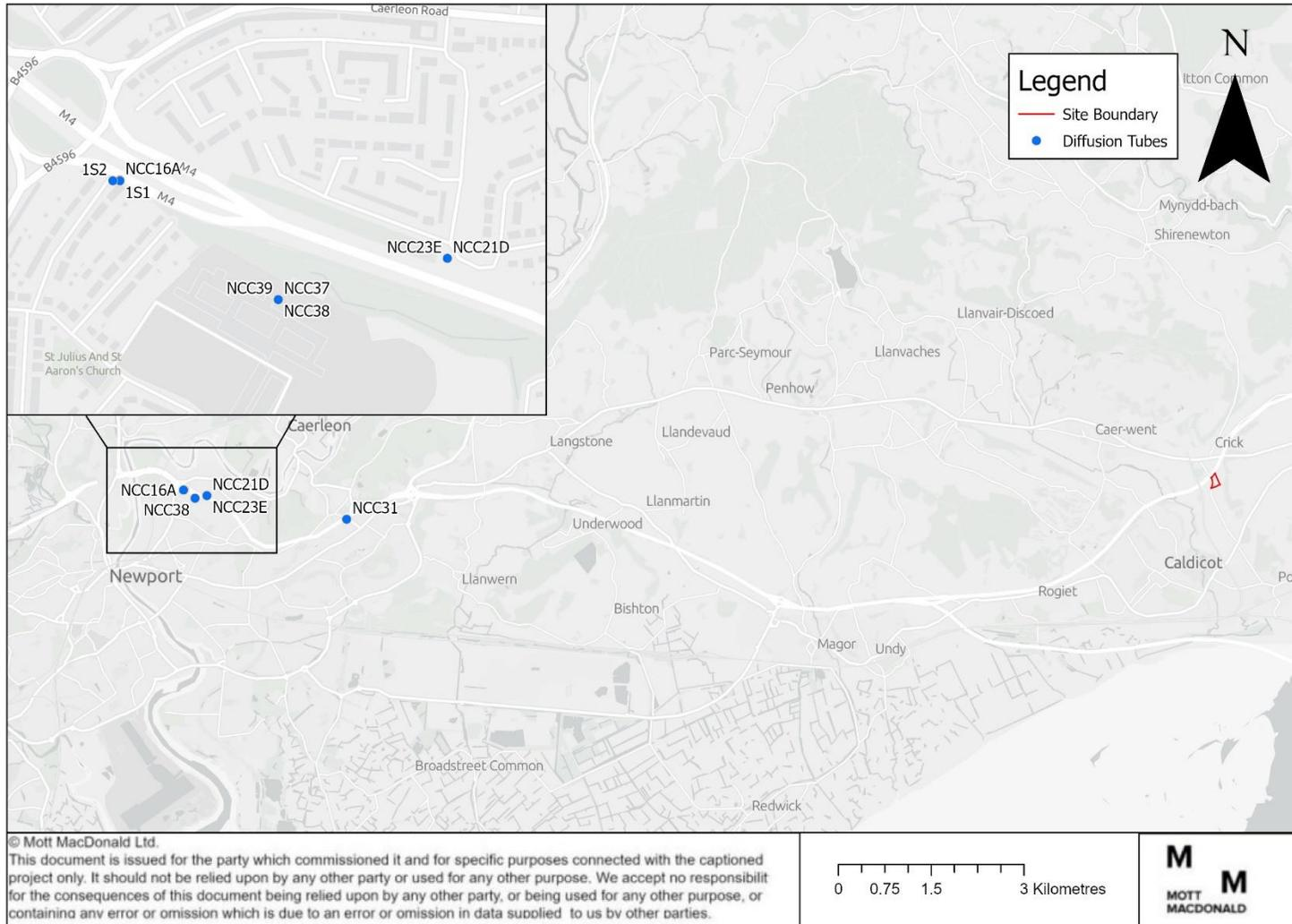

Page 784



### 4.3 Defra projected background concentrations

Defra provides mapped future year projections of background pollution concentrations for NO<sub>x</sub>, NO<sub>2</sub>, PM<sub>10</sub> and PM<sub>2.5</sub> for each 1km grid square across the UK for all years between 2018 to 2030<sup>33</sup>. The maps include a breakdown of background concentrations by emission source, including road and industrial sources, which have been calibrated against 2018 (the baseline year) UK monitoring data. Table 4.3 presents the background concentrations for the 1km grid square containing the Proposed Gypsy & Travellers Site in the current year of 2024. The background concentrations at the Proposed Gypsy & Travellers Site are all within the relevant objectives. Table 443 presents the background concentrations for the 1km grid square containing the Proposed Gypsy & Travellers Site in the baseline year of 2019.

**Table 4.3: Defra projected background concentrations of NO<sub>x</sub>, NO<sub>2</sub>, PM<sub>10</sub>, PM<sub>2.5</sub>, for proposed development in 2024 (µg/m<sup>3</sup>)**

1km Grid Square Location (OS Grid Reference)		2024 background concentration (µg/m <sup>3</sup> )			
X	Y	NO <sub>2</sub>	NO <sub>x</sub>	PM <sub>10</sub>	PM <sub>2.5</sub>
348500	189500	6.1	8.5	11.7	7.4
349500	189500	6.7	7.7	11.3	7.1

Source: <https://uk-air.defra.gov.uk/data/laqm-background-maps?year=2018>

**Table 4.4: Defra projected background concentrations of NO<sub>x</sub>, NO<sub>2</sub>, PM<sub>10</sub>, PM<sub>2.5</sub>, for proposed development in 2019 (µg/m<sup>3</sup>)**

1km Grid Square Location (OS Grid Reference)		2019 background concentration (µg/m <sup>3</sup> )			
X	Y	NO <sub>2</sub>	NO <sub>x</sub>	PM <sub>10</sub>	PM <sub>2.5</sub>
348500	189500	8.2	10.8	12.5	7.9
349500	189500	8.4	9.5	12.1	7.7

Source: <https://uk-air.defra.gov.uk/data/laqm-background-maps?year=2018>

### 4.4 Pollution Climate Model (PCM)

Defra uses the Pollution Climate Model (PCM) to report compliance with the limit values transposed into UK law from the Air Quality Directive<sup>34</sup>. PCM projections of NO<sub>2</sub> concentrations are available for all years from 2018 to 2030 from the base year of 2018. In general, predicted NO<sub>2</sub> concentrations decline into the future, mainly in response to cleaner vehicles and technologies, and actions in Air Quality Action Plans by local and combined authorities. The most recent PCM model results were published in 2020 and the projections represent the projected concentrations assuming no further action beyond the air quality measures that were committed by the reference year (2018).

The PCM links located closest to the Proposed Gypsy & Travellers Site are displayed in Figure 4.3 below. The PCM model predicts the greatest 2024 annual mean NO<sub>2</sub> concentration of 26.2 µg/m<sup>3</sup>, located at census ID 802010500. This is well below the annual mean limit value of

<sup>33</sup> Defra Background maps (2018) [Online]. Available at: <https://uk-air.defra.gov.uk/data/laqm-background-maps>

<sup>34</sup> 2. European Union. (April 2008) Directive on Ambient Air Quality and cleaner Air for Europe, Directive 2008/50/EC Official Journal, vol. 152, pp. 0001-0044

40µg/m<sup>3</sup> for NO<sub>2</sub>. On this basis, the risk of a limit value non-compliance or delaying compliance with limit values is low and is therefore not considered further.

**Figure 4.3: Nearby PCM links**

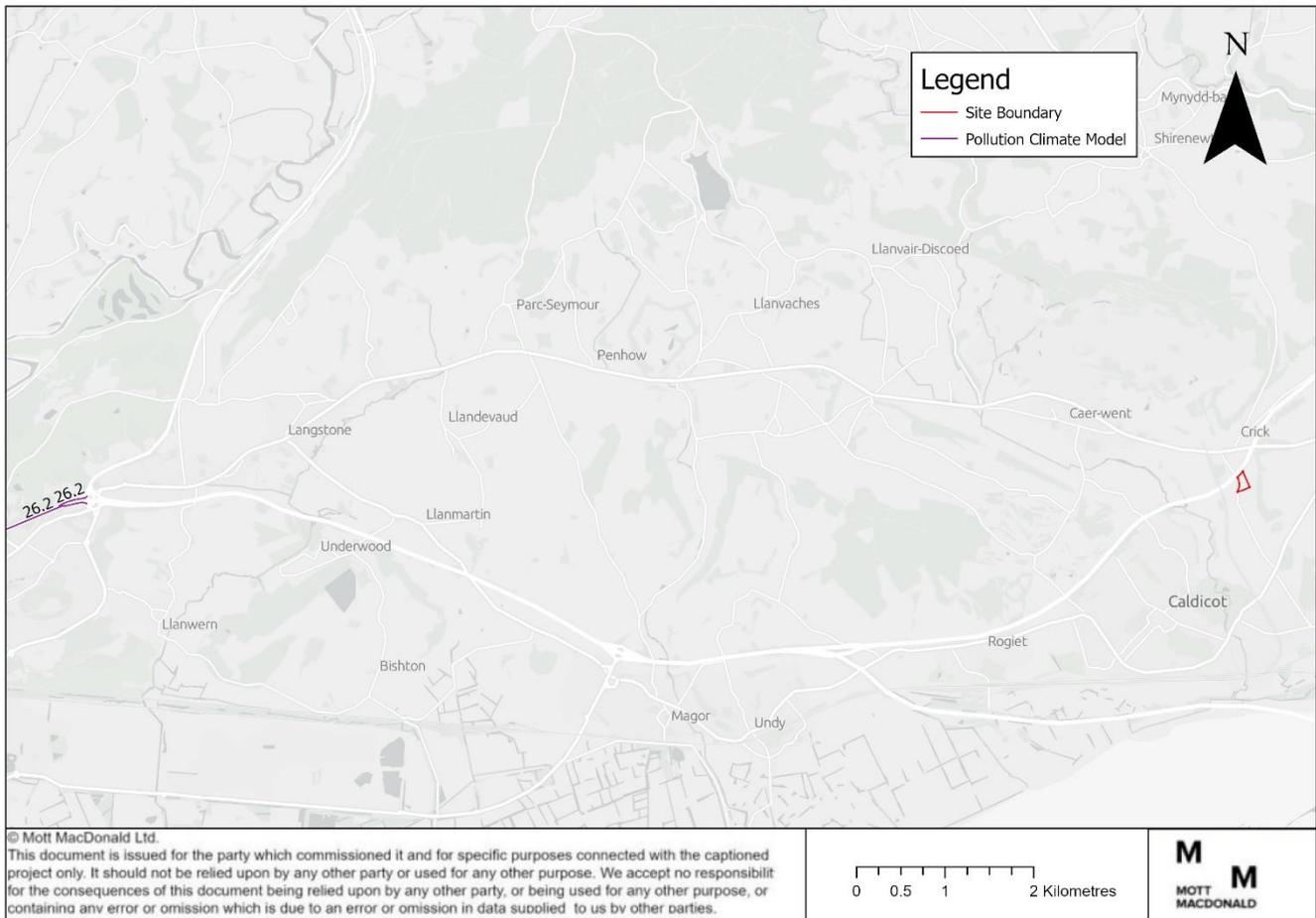

#### 4.5 Local emission sources

The main source of local emissions that could adversely impact the Proposed Gypsy & Travellers Site is the M48 motorway immediately surrounding northwest of the Proposed Gypsy & Travellers Site and the A48 to north of the Proposed Gypsy & Travellers Site. An existing rail line is located 2km south to the Proposed Gypsy & Travellers Site. It is not expected that there will be any significant impact from diesel train movements on ambient air quality. In accordance with guidance produced by Defra (TG22)<sup>26</sup>, exceedances of the NO<sub>2</sub> annual mean objectives nearby to rail line are unlikely if the background annual mean NO<sub>2</sub> concentration is well under 25µg/m<sup>3</sup>, as is the case here. A review of the Defra's UK Pollutant Release and Transfer Register public register<sup>35</sup> shows there are no permits issued within 1km of the Proposed Gypsy & Travellers Site.

#### 4.6 Summary

The Proposed Gypsy & Travellers Site is a roadside background location given that it is located approximately 20m away from the nearest motorway, the M4 motorway. As such, the urban

<sup>35</sup> Defra. Available at: [Search by map - Defra, UK](#)

background monitoring site AN1 and AN2 are considered to be representative as they are located next to M4 motorway. Further, the roadside diffusion tubes selected in Section 4.2.2.2 were also considered to be the most representative due to the Proposed Gypsy & Travellers Site location next to the motorway. Both automatic sites show data that is far below the objective of  $40\mu\text{g}/\text{m}^3$ . As such, it is unlikely that the addition of roadside  $\text{NO}_2$  concentrations associated with the Proposed Gypsy & Travellers Site would lead to an exceedance of the annual mean  $\text{NO}_2$  objective.

The annual mean  $\text{PM}_{10}$  concentration recorded at AN1 are also well below the objective of  $40\mu\text{g}/\text{m}^3$ . The  $\text{PM}_{2.5}$  concentration recorded at both of the monitoring sites is also far below the applicable standard of  $20\mu\text{g}/\text{m}^3$ . Given that recorded  $\text{PM}_{10}$  and  $\text{PM}_{2.5}$  monitored concentrations are well below the relevant objectives these pollutants have not been considered further within this report.

#### 4.7 Mitigation

As the site is considered suitable for the proposed users, no additional mitigation measures are expected to be required. However, it should be ensured that the policies relating to air quality outlined in the Monmouthshire Local Plan and Newport Local Plan, as detailed in Section 2.3.2, are considered within the design and operation of the Proposed Gypsy & Travellers Site.

## 5 Potential Impacts

### 5.1 Overview

This section presents the air quality impacts predicted to occur at sensitive receptor locations due to the construction of the Proposed Gypsy & Travellers Site. Results are presented for 2024 as this is the baseline year and considered to be most presentative.

### 5.2 Site suitability

Table 5.1 presents the predicted changes and resultant annual mean NO<sub>2</sub> pollutant concentrations at the worst-case receptor for the Proposed Gypsy & Travellers Site, presented within Table 3.2.

**Table 5.1: Predicted impact on NO<sub>2</sub> concentrations at the Proposed Gypsy & Travellers Site and sensitive receptor**

ID	2024 annual mean NO <sub>2</sub> (µg/m <sup>3</sup> )	Annual mean NO <sub>2</sub> objective (µg/m <sup>3</sup> )
R1	10.1	40.0

Table 5.1 highlights that results are well below the NO<sub>2</sub> annual mean objective of 40 µg/m<sup>3</sup> at the worst-case receptor. It can therefore be considered that the Proposed Gypsy & Travellers Site is suitable, in terms of air quality, for the introduction of additional receptors.

### 5.3 Mitigation

Considering the predicted air quality impact of the Proposed Gypsy & Travellers Site are predicted to be suitable for the introduction of additional receptors, no additional mitigation measures are expected to be required.

## 6 Conclusions

This report provides an assessment of the suitability of the Proposed Gypsy & Travellers Site for the future proposed users.

A review of the existing air quality information indicates that exceedances of the 1-hour mean NO<sub>2</sub>, 24-hour mean PM<sub>10</sub> and annual mean NO<sub>2</sub>, PM<sub>10</sub> and PM<sub>2.5</sub> objectives are unlikely at the Proposed Gypsy & Travellers Site. At a receptor, chosen to represent the worst-case location on the Gypsy & Travellers Site, is predicted to be well below the NO<sub>2</sub> objective. The Proposed Gypsy & Travellers Site is therefore considered suitable for the proposed users in terms of long-term and short-term exposure to pollutant concentrations.

Results presented within this report are not considered to conflict with any national, regional or local planning policy.



A large teal graphic element consisting of a triangle at the top and a vertical rectangle below it, with a diagonal cutout on the left side.

# **Proposed Gypsy and Travellers Site Langley Close, Magor**

Air Quality Assessment

February 2024

This page left intentionally blank for pagination.



Mott MacDonald  
10 Livery Street  
Birmingham B3 2NU  
United Kingdom

T +44 (0)121 234 1500  
mottmac.com

# **Proposed Gypsy and Travellers Site Langley Close, Magor**

**Air Quality Assessment**

February 2024

# Issue and Revision Record

Revision	Date	Originator	Checker	Approver	Description
PO1	February 2024	T. Malik-Agrawal / H. Whalley	A. Lithgow-Dick	N. Cummins	First draft

**Document reference:** 100115516 | AQ001 | P01 |

**Information class:** Standard

---

This document is issued for the party which commissioned it and for specific purposes connected with the above-captioned project only. It should not be relied upon by any other party or used for any other purpose.

We accept no responsibility for the consequences of this document being relied upon by any other party, or being used for any other purpose, or containing any error or omission which is due to an error or omission in data supplied to us by other parties.

This document contains confidential information and proprietary intellectual property. It should not be shown to other parties without consent from us and from the party which commissioned it.

---

# Contents

<b>1</b>	<b>Introduction</b>	<b>1</b>
1.1	Overview	1
1.2	Proposed development location	1
<b>2</b>	<b>Legislation and policy</b>	<b>3</b>
2.1	Overview	3
2.2	Legislation	3
2.3	Policy	4
<b>3</b>	<b>Methodology</b>	<b>10</b>
3.1	Overview	10
3.2	Traffic data used in assessment	10
3.3	Model selection	10
3.4	Emissions data	10
3.5	Receptors	11
3.6	NO <sub>x</sub> to NO <sub>2</sub> relationship	12
3.7	Predicted 1-Hour concentrations	12
3.8	Assessment criteria	12
3.9	Assumptions and limitations	12
<b>4</b>	<b>Baseline</b>	<b>13</b>
4.1	Overview	13
4.2	Local authority review and assessment	13
4.3	Defra projected background concentrations	19
4.4	Pollution Climate Model (PCM)	19
4.5	Local emission sources	20
4.6	Summary	20
4.7	Mitigation	21
<b>5</b>	<b>Potential Impacts</b>	<b>22</b>
5.1	Overview	22
5.2	Site suitability	22
5.3	Mitigation	22
<b>6</b>	<b>Conclusions</b>	<b>23</b>

## Tables

Table 2.1: Relevant air quality objectives and limit values	8
Table 2.2: Locations where the air quality objectives apply	9
Table 3.1: Traffic data	10
Table 3.2: Modelled receptors	11
Table 4.1: Automatic monitoring results	14
Table 4.2: Diffusion tube monitoring results	17
Table 4.3: Defra projected background concentrations of NO <sub>x</sub> , NO <sub>2</sub> , PM <sub>10</sub> , PM <sub>2.5</sub> , for proposed development in 2024 (µg/m <sup>3</sup> )	19
Table 4.4: Defra projected background concentrations of NO <sub>x</sub> , NO <sub>2</sub> , PM <sub>10</sub> , PM <sub>2.5</sub> , for proposed development in 2019 (µg/m <sup>3</sup> )	19
Table 5.1: Predicted impacts on NO <sub>2</sub> concentrations at the proposed Gypsy & Travellers Site and sensitive receptors	22

## Figures

Figure 1.1: Site location	2
Figure 3.1: Location of modelled receptors	11
Figure 4.1: Automatic monitoring locations	15
Figure 4.2: Diffusion tube locations	18
Figure 4.3: Nearby PCM links	20

# 1 Introduction

## 1.1 Overview

Mott MacDonald has been appointed by Monmouthshire County Council (MCC) to provide an air quality report as part of MCC's Gypsy and Traveller Accommodation Assessment (GTAA) identification study for the Langley Close site in Magor, Monmouthshire (hereafter referred to as "the proposed Gypsy and Traveller site") one of the three council-owned identified sites for potential development. The proposed Gypsy and Travellers site is understood to comprise the construction of up to six pitches that will include parking and a collective utility block with access gained via St Bride's Road which runs along the eastern boundary of the site.

This report provides a summary of existing air quality information around the proposed Gypsy & Traveller Site and an assessment of the suitability of the site for the proposed users. The energy demand for the proposed Gypsy & Travellers Site is unknown at the moment, but it is expected to be of a typical bricks and mortar dwelling, with electricity and water supply at the minimum. It is expected that this would not extend to gas supply.

In order to assess site suitability, two types of assessment have been undertaken. Firstly, a qualitative review of local and national air quality monitoring data and secondly, a quantitative Design Manual for Roads and Bridges (DMRB) calculation spreadsheet assessment, using the latest Department for Transport (DfT) traffic count data from 2022 for the M4. In addition, the assessment considers the suitability of air quality at the proposed development for the introduction of additional receptors in accordance with Environmental Protection UK (EPUK) and Institute of Air Quality Management (IAQM) guidance by considering the location of the proposed Gypsy & Travellers Site in relation to existing emission sources. No site-specific monitoring has been undertaken due to existing local authority and national monitoring data already being available.

No assessment of the potential impacts associated with the construction of the proposed Gypsy & Travellers Site, such as nuisance, loss of amenity and health impacts caused by construction dust, have been undertaken at this stage. Construction impacts are likely to be temporary and can be controlled using appropriate mitigation in a Construction Environmental Management Plan (CEMP). An assessment of construction impacts is therefore not required at the feasibility stage.

## 1.2 Proposed development location

The proposed Gypsy & Travellers Site is located to the north of Magor, Monmouthshire. The proposed Gypsy & Travellers Site is bound by residential properties to the south and southeast. Saint Bride's Road bounds the proposed Gypsy & Travellers Site to the east, with fields to the west, adjacent to M4 Junction 23a. The M4 Junction 23a westbound offslip is located directly north of the proposed Gypsy & Travellers Site. An undulating bank of trees separate the proposed Gypsy & Travellers Site from the motorway, which is approximately 18m at its narrowest point. The proposed Gypsy & Travellers Site is located within the administrative area of MCC. The proposed Gypsy & Travellers Site is also located 800m to the east of the boundary of Newport City Council (NCC), therefore has also been taken into consideration. The location of the proposed Gypsy & Travellers Site and the district council boundaries are presented in Figure 1.1.

Figure 1.1: Site location

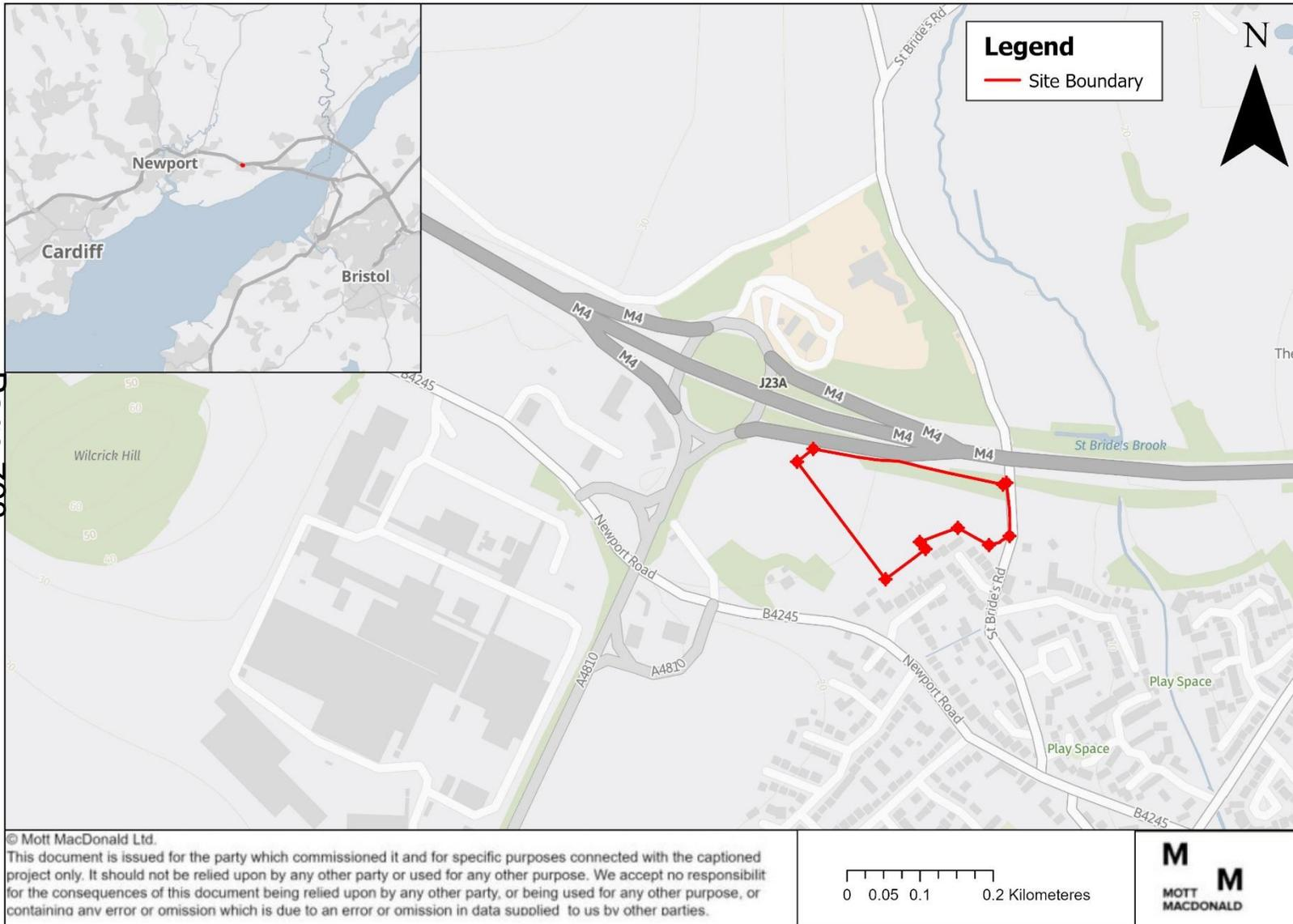

Page 798

## 2 Legislation and policy

### 2.1 Overview

This section summarises the relevant international and national legislation, policy and planning guidance in relation to air quality. In addition, local planning policy guidance has been reviewed in order to identify air quality policy implications related to the proposed Gypsy & Travellers Site.

### 2.2 Legislation

#### 2.2.1 Wales

The European Union Directive on ambient air quality and cleaner air for Europe (2008/50/EC)<sup>1</sup> sets legally binding limits for pollutant concentrations. This directive was made law in the Wales through The Air Quality Standards (Wales) Regulations 2010<sup>2</sup> (amended by The Air Quality Standards (Wales) (Amendment) (EU Exit) Regulations 2019<sup>3</sup> and the Environment (Miscellaneous Amendments) (EU Exit) Regulations 2020<sup>4</sup>).

This Directive defines limit values and times by which they are to be achieved for the purpose of protecting human health and the environment by avoiding, reducing or preventing harmful concentrations of air pollutants. The Limit Values within the Directive are intended to apply everywhere with the exception of:

- any locations situated within areas where members of the public do not have access and there is no fixed habitation
- in accordance with Article 2(1), on factory premises or at industrial installations to which all relevant provisions concerning health and safety at work apply
- on the carriageway of roads, and
- on the central reservations of roads except where there is normally pedestrian access to the central reservation.

Part IV of the Environment Act 1995<sup>5</sup> (as amended in Schedule 11 of the Environment Act 2021<sup>6</sup>) requires that every local authority shall carry out a review of air quality within its designated area, including predictions of likely future air quality. The air quality objectives specifically for use by local authorities in carrying out their air quality management duties are set out in The Air Quality (Wales) Regulations 2000<sup>7</sup> and The Air Quality (Wales) (Amendment) Regulations 2002<sup>8</sup>. In most cases, the air quality objectives are set at the same pollutant concentrations as the limit values transposed into UK law although compliance dates differ.

As part of the review of air quality, the local authority must assess whether air quality objectives are being achieved or are likely to be achieved within the relevant periods and identify the relevant sources of emissions it considers responsible for the failure to achieve the objectives. Any parts of a local authority's area where the objectives are not being achieved or are not likely

---

<sup>1</sup> The European Parliament and the Council of the European Union (2008) Directive 2008/50/EC of the European Parliament and of the Council

<sup>2</sup> Statutory Instrument (2010) The Air Quality Standards (Wales) Regulations

<sup>3</sup> Statutory Instrument (2019) The Air Quality Standards (Wales) (Amendment) (EU Exit) Regulations

<sup>4</sup> Statutory Instrument (2020) Environment (Miscellaneous Amendments) (EU Exit) Regulations 2020, No. 1313.

<sup>5</sup> Department for Environment Food and Rural Affairs. (2009). Part IV of the Environment Act 1995 Local Air Quality Management Policy Guidance (PG09). London: Defra.

<sup>6</sup> Statutory Instrument. (2021) Chapter 30, Schedule 11 Local Air Quality Management Framework of Environment Act 2021

<sup>7</sup> Statutory Instrument (2000) The Air Quality (Wales) Regulations, No. 1940 (W.138).

<sup>8</sup> Statutory Instrument (2002) The Air Quality (Amendment) (Wales) Regulations, No. 3182 (W.298).

to be achieved within the relevant period must be identified and declared as an Air Quality Management Area (AQMA). Once such a declaration has been made, local authorities are under a duty to prepare an Action Plan which sets out measures to pursue the achievement of the air quality objectives within the AQMA.

The Environment Act 1995 requires the UK Government to produce a national Air Quality Strategy (AQS). The AQS establishes the UK framework for air quality improvements. Measures agreed at the national and international level are the foundations on which the strategy is based. The first AQS, first adopted in 1997<sup>9</sup> and its subsequent iterations, have now been superseded as of the 14th January 2019 with the Clean Air Strategy 2019 (CAS).<sup>10</sup>

The CAS does not set legally binding objectives, the CAS instead has targets for reducing total UK emissions of NO<sub>x</sub> and fine particulate matter (PM<sub>2.5</sub>) from sectors such as road transport, domestic sources and construction plant (non-road mobile machinery (NRMM)).

Further to this, the UK Government has produced a draft AQS revision in 2023. This revision replaces the 2007 strategy and compliments the CAS. The 2023 revision sets out the actions the government expects local authorities in England to take in support of achieving the Government's long-term air quality goals, including their two new long-term PM<sub>2.5</sub> targets. The AQS does not mention local authorities in Wales and as such the long-term PM<sub>2.5</sub> targets currently only apply to England. Therefore, the revised draft AQS and new targets are not applicable to this project at the time of writing. However, the Welsh Government have published their own 'Clean Air Plan' for Wales in 2019 to provide a framework and actions for air quality improvements within Wales.

## 2.3 Policy

### 2.3.1 Air Quality Strategy

Part IV of the Environment Act 1995<sup>11</sup> (as amended in Schedule 11 of the Environment Act 2021<sup>12</sup>) places a duty on the Secretary of State for the Environment to develop, implement and maintain an Air Quality Strategy with the aim of reducing atmospheric emissions and improving air quality. The Air Quality Strategy provides air quality standards and objectives for key air pollutants, which are designed to protect human health and the environment and sets out how the different sectors: industry, transport and local government, can contribute to achieving the air quality objectives.

The first Air Quality Strategy for England, Scotland, Wales and Northern Ireland was published in 2007<sup>13</sup> and has now been superseded as of the 14th January 2019 with the Clean Air Strategy 2019 (CAS)<sup>14</sup>. Although the CAS has been developed at a UK level, the Welsh Government have also published their own 'Clean Air Plan' for Wales in 2019 to provide a framework and actions for air quality improvements within Wales. The CAS has targets for reducing total UK emissions of nitrogen oxides (NO<sub>x</sub>) and fine particulate matter (PM<sub>2.5</sub>) from sectors such as road transport, domestic sources and construction plant (non-road mobile machinery or NRMM).

---

<sup>9</sup> Department for Environment Food and Rural Affairs. (March 1997), 'The United Kingdom National Air Quality Strategy', Cm 3587, Department for Environment Food and Rural Affairs.

<sup>10</sup> Department for Environment Food and Rural Affairs. (January 2019), 'The Clean Air Strategy'

<sup>11</sup> Department for Environment Food and Rural Affairs (2003) Part IV of the Environment Act 1995 Local Air Quality Management.

<sup>12</sup> Statutory Instrument. (2021) Chapter 30, Schedule 11 Local Air Quality Management Framework of Environment Act 2021.

<sup>13</sup> Defra (2007) The Air Quality Strategy for England, Scotland, Wales and Northern Ireland

<sup>14</sup> Defra (2019) The Clean Air Strategy



### 2.3.2 Statutory nuisance

Section 79(1)(d) of the Environmental Protection Act 1990<sup>15</sup> defines one type of 'statutory nuisance' as "any dust, steam, smell or other effluvia arising on industrial, trade or business premises and being prejudicial to health or a nuisance". Where a local authority is satisfied that a statutory nuisance exists, or is likely to occur or recur, it must serve an abatement notice. Failure to comply with an abatement notice is an offence. 'Best practicable means' is a widely used defence by operators, if used to prevent or to counteract the effects of the nuisance.

### 2.3.3 National policy

#### 2.3.3.1 Planning Policy

The current air quality planning policies for the Welsh Government are set out in Planning Policy Wales Edition 11 (February 2021)<sup>16</sup>. Those relevant to air quality are:

- Chapter 3 'Strategic and Spatial Choices', which highlights the importance of promoting healthier places through the planning system. This includes enabling opportunities for outdoor activities, good design in planning to minimise exposure to poor air quality, reduction of health inequalities and making positive contributions to environmental protection and improvement, including air quality.
- Chapter 4 'Active and Social Places', which states that the Welsh Government is committed to supporting modal shift from private cars to walking, cycling and public transport and that local authorities must adopt an integrated approach to traffic management, also considering wider planning objectives such as improvement in air quality.
- Chapter 5 'Productive and Enterprising Places' details that planning authorities should take into account the need to minimise impacts on local communities and the natural environment and that any minerals proposals must set out criteria to prevent adverse impacts upon these receptors.
- Chapter 6 'Distinctive and Natural Places' states that development plan strategies, policies and development proposals should look to the long-term protection and enhancement of the built and natural environment in order to achieve Wales's wellbeing goals. This includes considering effects of development proposals on air quality with the aim to reduce population exposure to air pollution in Wales.

Planning Policy Wales (PPW) is supplemented by a series of topic-based Technical Advice Notes (TANs). TAN 18 Transport details the importance of good air quality, and states: "*well designed and implemented traffic management can help secure planning objectives...[by]... reducing...local air pollution...*".

In June 2017, the Welsh Government set out further provisions in Policy guidance PG(W)(17)<sup>17</sup>, which adopts five ways of working set out in the Well-being of Future Generations (Wales) Act 2015<sup>18</sup> with the intention to improve the economic, social, environmental and cultural well-being of Wales in accordance with the sustainable development principles. The five ways of working are:

- "*looking to the long term so we do not compromise the ability of future generations to meet their own needs;*

---

<sup>15</sup> Parliament of the United Kingdom. (1990), 'Environmental Protection Act', Chapter 43. Queen's Printer of Acts of Parliament.

<sup>16</sup> Welsh Government. (2021) Planning Policy Wales. Edition 11. [online] Available at: [https://gov.wales/sites/default/files/publications/2021-02/planning-policy-wales-edition-11\\_0.pdf](https://gov.wales/sites/default/files/publications/2021-02/planning-policy-wales-edition-11_0.pdf)

<sup>17</sup> Welsh Government (2017) Local air quality management in Wales. Part of the Environment Act 1995. Policy guidance PG(W)(17)

<sup>18</sup> Welsh Government (2015) Well-being of Future Generations (Wales) Act 2015.

- *taking an integrated approach;*
- *involving a diversity of the population in the decisions affecting them;*
- *working with others in a collaborative way to find shared sustainable solutions; and*
- *acting to prevent problems from occurring or getting worse.”*

Welsh local authorities are expected to follow these ways of working when carrying out their LAQM duties.

The Welsh Government published The Wales Transport Strategy<sup>19</sup> in 2021, which sets out the Government’s main transport development aims and how these will be achieved. The strategy contains long-term health and environmental outcomes for transport in Wales; “*Chapter 03. Well-being ambitions*” aims to improve air quality *through “encouraging more active travel, greater use of public transport and low emissions vehicles, and by creating closer links between land-use planning and transport in line with our commitments in the Clean Air Plan for Wales.”*

### 2.3.3.2 Air Quality Plan for Nitrogen Dioxide in the UK

The latest plan for tackling roadside NO<sub>2</sub> concentrations was published by Defra in July 2017 and details the government’s plan to reduce NO<sub>2</sub> concentrations within statutory limits within the shortest possible time<sup>20</sup>. Within this plan, several named local authorities with exceedances of the NO<sub>2</sub> limit values are required to undertake a local assessment to consider the best options to achieve compliance with this limit value. The Welsh Government published a supplemental plan<sup>21</sup> to the UK plan in November 2018 to provide additional information of which measures would ensure compliance with the limit values for NO<sub>2</sub> within Wales in the shortest possible time.

The proposed Gypsy & Travellers Site is within the South Wales Zone (UK0041), which is covered by a zone-specific Air Quality Plan<sup>22</sup>. Baseline model projections of South Wales from 2017 to 2030 in the Air Quality Plan shows that maximum modelled annual mean NO<sub>2</sub> concentration is predicted to drop to 42µg/m<sup>3</sup> by 2025. No specific measure is required for Monmouthshire County Council or Newport City Council.

## 2.3.4 Local policy

### 2.3.4.1 Monmouthshire County Council Adopted Local Development Plan

The Monmouthshire Adopted Local Plan<sup>23</sup> was adopted in 2011 and set out frameworks for development across Monmouthshire up to 2021. The main policy of relevance is Policy EP1 ‘Amenity and Environmental Protection’, which states that:

- *‘Development, including proposals for new buildings, extensions to existing buildings and advertisements, should have regard to the privacy, amenity and health of occupiers of neighbouring properties.*
- *Development proposals that would cause or result in an unacceptable risk /harm to local amenity, health, the character /quality of the countryside or interests of nature conservation,*

---

<sup>19</sup> Welsh Assembly Government (2008). One Wales: Connecting the Nation. The Wales Transport Strategy. [online] <https://gov.wales/sites/default/files/publications/2017-09/wales-transport-strategy.pdf>

<sup>20</sup> Defra (2017) UK plan for tackling roadside nitrogen dioxide concentrations: Detailed Plan [online] Available at: [https://assets.publishing.service.gov.uk/government/uploads/system/uploads/attachment\\_data/file/633270/air-quality-plan-detail.pdf](https://assets.publishing.service.gov.uk/government/uploads/system/uploads/attachment_data/file/633270/air-quality-plan-detail.pdf)

<sup>21</sup> Welsh Government. 2018. Welsh Government supplemental plan to the UK plan for tackling roadside nitrogen dioxide concentrations 2017: Tackling roadside nitrogen dioxide concentrations in Wales. [online] Available at: <https://gov.wales/sites/default/files/publications/2019-04/tackling-roadside-nitrogen-dioxide-concentrations-in-wales.pdf>

<sup>22</sup> Defra (2017) Air Quality Plan for tackling roadside nitrogen dioxide concentrations in North Wales (UK0042). [online] [https://uk-air.defra.gov.uk/assets/documents/no2ten/2017-zone-plans/AQplans\\_UK0041.pdf](https://uk-air.defra.gov.uk/assets/documents/no2ten/2017-zone-plans/AQplans_UK0041.pdf)

<sup>23</sup> Monmouthshire County Council (2014) Adopted Local Development Plan (2011-2021)

*landscape or built heritage importance due to the following will not be permitted, unless it can be demonstrated that measures can be taken to overcome any significant risk:*

- *Air pollution;*
- *Light pollution;*
- *Noise pollution;*
- *Water pollution;*
- *Contamination;*
- *Land instability;*
- *Or any identified risk to public health or safety'*

#### 2.3.4.2 Replacement Local Development Plan Overview

The Replacement Local Development Plan (RLDP)<sup>24</sup> is in progress by the MCC to improve the Local Development Plan mentioned in Section 2.3.2. for implementation up to 2033. The two main RLDP points of relevance are Objective 17 'Climate and Nature Emergency' which states that:

- *'To strive to limit the increase in global temperatures to 1.5°C, supporting carbon reduction through a variety of adaptation measures including facilitating resilient ecosystems and nature recovery, the use of renewable energy, net zero ready homes, the design and location of new development, encouraging balanced job and population growth to reduce out-commuting, the provision of broadband connectivity to reduce the need to travel, the provision of ultra-low emission vehicle charging infrastructure to reduce emissions and improve air quality, and the provision of quality Green Infrastructure.'*

Strategic Policy S4 'Climate Change' Point VII which states:

- *'Providing ultra-low emission vehicle charging infrastructure to reduce emissions and improve air quality.'*

#### 2.3.4.3 Newport City Council Local Development Plan

The Newport Adopted Local Plan<sup>25</sup> was adopted in 2015 and set out frameworks for development across Newport up to 2026. The main policies of relevance are Policy SP14 'Transport Proposals' Point IX which states:

- *'Transport proposals will be supported where they result in other environmental improvements including air quality, noise reductions, sustainable drainage and enhanced biodiversity.'*

Policy GP2 'General Development Principles – General Amenity' which states that:

- Development will be permitted where, as applicable:
  - *'there will not be a significant adverse effect on local amenity, including in terms of noise, disturbance, privacy, overbearing, light, odours and air quality;*
  - *the proposed use and form of development will not be detrimental to the visual amenities of nearby occupiers or the character or appearance of the surrounding area;*
  - *the proposal seeks to design out the opportunity for crime and anti-social behaviour;*

---

<sup>24</sup> Monmouthshire County Council (2023) Replacement Local Development Plan

<sup>25</sup> Monmouthshire County Council (2014) Adopted Local Development Plan (2011-2021)

- *the proposal promotes inclusive design both for the built development and access within and around the development;*
- *adequate amenity for future occupiers.’*

Policy GP4 ‘General Development Principles – Highway and Accessibility’ which states that:

- Development proposals should:
  - *‘provide appropriate access for pedestrians, cyclists and public transport in accordance with national guidance;*
  - *be accessible by a choice of means of transport;*
  - *be designed to avoid or reduce transport severance, noise and air pollution; iv) make adequate provision for car parking and cycle storage;*
  - *provide suitable and safe access arrangements;*
  - *design and build new roads within private development in accordance with the highway authority’s design guide and relevant national guidance;*
  - *ensure that development would not be detrimental to highway or pedestrian safety or result in traffic generation exceeding the capacity of the highway network.’*

Policy GP7 ‘General Development Principles – Environmental Protection and Public Health’ which states that:

- *‘Development will not be permitted which would cause or result in unacceptable harm to health because of land contamination, dust, instability or subsidence, air, heat, noise or light pollution, flooding, water pollution, or any other identified risk to environment, local amenity or public health and safety.’*

### 2.3.5 Summary

Air quality objectives and limit values are summarised in Table 2.1.

**Table 2.1: Relevant air quality objectives and limit values**

Pollutant	Averaging Period	Concentration	Allowance	Attainment Date	
				Air Quality Objectives	Limit Values
Nitrogen dioxide (NO <sub>2</sub> )	Annual	40 µg/m <sup>3</sup>	-	31 December 2005 <sup>(a)</sup>	1 January 2010 <sup>(c)</sup>
	1 Hour	200 µg/m <sup>3</sup>	18	31 December 2005 <sup>(a)</sup>	1 January 2010 <sup>(c)</sup>
Particulates (PM <sub>10</sub> )	Annual	40 µg/m <sup>3</sup>	-	31 December 2004 <sup>(a)</sup>	1 January 2005 <sup>(c)</sup>
	24 Hour	50 µg/m <sup>3</sup>	35	31 December 2004 <sup>(a)</sup>	1 January 2005 <sup>(c)</sup>
Fine particulates (PM <sub>2.5</sub> ) <sup>(d)</sup>	Annual	20 µg/m <sup>3</sup>	-	-	1 January 2020 <sup>(c)</sup>
		25 µg/m <sup>3</sup>	-	2020 <sup>(b)</sup>	-

Notes: <sup>(a)</sup> Air Quality (Wales) Regulations 2000 as amended

<sup>(b)</sup> Air Quality Strategy 2007

<sup>(c)</sup> EU Directive 2008/50/EEC on ambient air quality and cleaner air for Europe, as transposed into UK Law

<sup>(d)</sup> As the Air Quality Strategy 2007 and EU Directive 2008/50/EC have a different numerical standard for PM<sub>2.5</sub>, the more stringent standard of 20µg/m<sup>3</sup> has been adopted for this assessment.

Table 2.2 provides details of where the respective objectives should and should not apply and therefore the types of receptors that are relevant to the assessment of air quality.

**Table 2.2: Locations where the air quality objectives apply**

<b>Averaging Period</b>	<b>Objectives should apply at:</b>	<b>Objectives should not apply at:</b>
Annual	All locations where members of the public might be regularly exposed. Building façades of residential properties, schools, hospitals, care homes, etc.	Building façades of offices or other places of work where members of the public do not have regular access. Hotels, unless people live there as their permanent residence. Gardens of residential properties. Kerbside sites (as opposed to locations at the building façade), or any other location where public exposure is expected to be short-term.
24-Hour	All locations where the annual mean objective would apply, together with hotels. Gardens of residential properties.	Kerbside sites (as opposed to locations at the building façade), or any other location where public exposure is expected to be short-term.
1-Hour	All locations where the annual mean and 24-hour mean objectives apply. Kerbside sites (for example, pavements of busy shopping streets). Those parts of car parks, bus stations and railway stations, etc., which are not fully enclosed, where members of the public might reasonably be expected to spend one hour or more. Any outdoor locations where members of the public might reasonably be expected to spend one hour or longer.	Kerbside sites where the public would not be expected to have regular access.

Source: Defra TG22<sup>26</sup>.

<sup>26</sup> Department for Environment, Food and Rural Affairs and Devolved Administrations (August 2022). Local Air Quality Management – Technical Guidance LAQM.TG22

## 3 Methodology

### 3.1 Overview

This Section provides the approach taken to consider the suitability of the proposed Gypsy & Travellers Site, key elements of which include model choice, traffic data, emission factors and dealing with uncertainty.

### 3.2 Traffic data used in assessment

The proposed Gypsy & Travellers Site has the potential to affect air quality by increasing traffic by increasing the number of vehicles on the road network and by affecting existing traffic through the introduction of more people visiting the site.

The traffic data used in this assessment was obtained from the Department for Transport (DfT)<sup>27</sup>, providing data on vehicle flows in annual average daily traffic flows (AADT), including heavy duty vehicle<sup>28</sup> (HDV) percentages and speeds (km/hr). The 2022 data has been used as the base year and for model verification as it is considered to be most representative. The data has been presented in Table 3.1.

**Table 3.1: Traffic data**

Road ID	Location Reference	AADT	%HDV	Speed (kph)
1	M4 Wilcrick	84428	9.7	112
2	M4 Magor	92052	10.8	112
3	A4810	7968	19.8	20 <sup>(a)</sup>
4	M4 Magor WB sliproad	3812	25.1	40
5	M4 Magor EB sliproad	3812	25.1	40

Notes: (a) indicates that speed data has been adjusted in accordance with TG22 guidance on speed at junctions.

### 3.3 Model selection

The DMRB calculation spreadsheet formulas have been used for this assessment in conjunction with the latest Local Air Quality Management (LAQM) tools provided by Defra. Only NO<sub>2</sub> has been considered within this assessment as ambient concentrations of PM<sub>10</sub> and PM<sub>2.5</sub> are well below the respective objectives (as indicated in Section 4). The emission factors for PM<sub>10</sub> and PM<sub>2.5</sub> are lower than NO<sub>2</sub>, therefore, the change in concentrations and associated impact magnitude associated with PM<sub>10</sub> and PM<sub>2.5</sub>, as a result of the proposed Gypsy & Travellers Site would be less than assessed for NO<sub>2</sub>.

### 3.4 Emissions data

Pollutant emissions from vehicles have been estimated using vehicle emission factors calculated from Defra's Emission Factor Toolkit (EFT), based on traffic flows, speeds and vehicle emission factors. The latest EFT (Version 12.0.1, released December 2023)<sup>29</sup> has been used within this assessment.

<sup>27</sup> Road traffic statistics - Manual count point: 74081 (dft.gov.uk)

<sup>28</sup> A HDV is any vehicle with a gross weight greater than 3.5 tonnes. This typically includes heavy goods vehicles (HGVs), buses and coaches

<sup>29</sup> [https://laqm.defra.gov.uk/wp-content/uploads/2023/12/EFT2023\\_v12.0.1.xlsb](https://laqm.defra.gov.uk/wp-content/uploads/2023/12/EFT2023_v12.0.1.xlsb)

### 3.5 Receptors

The air quality objectives only apply in locations of relevant exposure, as presented within Table 2.2: . There are no plans currently available highlighting the exact location of the facades of the proposed structures within the proposed Gypsy & Travellers Site. Receptors points have therefore been chosen at the boundary of the proposed Gypsy & Travellers Site to represent a worst-case location. The chosen receptors are presented within Table 3.2 and displayed in Figure 3.1.

**Table 3.2: Modelled receptors**

Receptor ID	National Grid reference		Height (m)
	X	Y	
R1	342076	187806	1.5
R2	342132	187796	1.5
R3	342056	187799	1.5

**Figure 3.1: Location of modelled receptors**

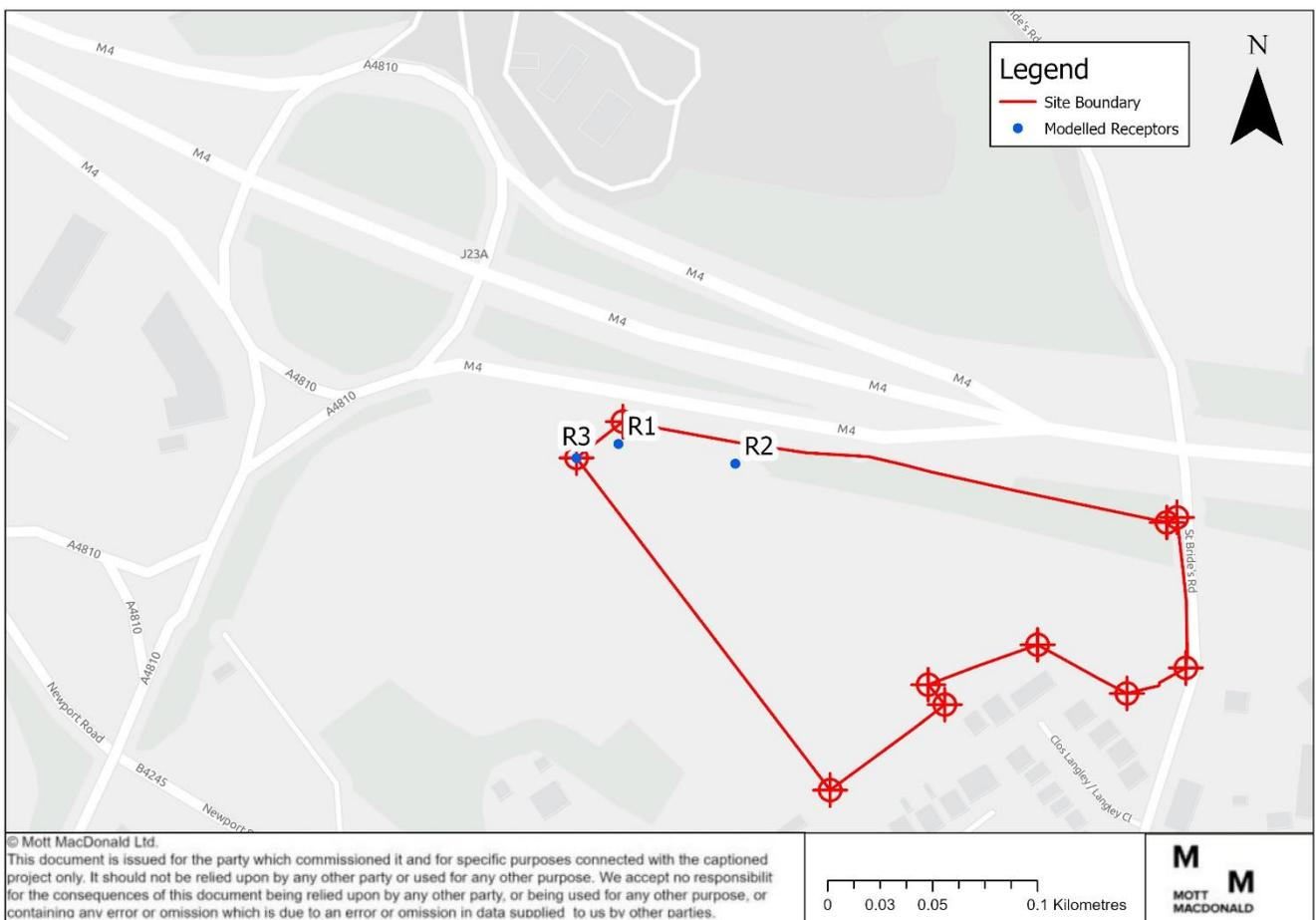

### 3.6 NO<sub>x</sub> to NO<sub>2</sub> relationship

The DMRB calculation spreadsheet formulas used for this assessment provides outputs for NO<sub>x</sub> which need to be converted to NO<sub>2</sub> to allow comparison with the relevant air quality objectives. Defra provides a spreadsheet-based method<sup>30</sup> for calculating annual mean NO<sub>x</sub> to NO<sub>2</sub> conversions. This method has been used within the assessment and is the most appropriate way of determining NO<sub>2</sub> concentrations from road NO<sub>x</sub> contributions.

### 3.7 Predicted 1-Hour concentrations

Guidance from Defra's TG22 indicates that the hourly NO<sub>2</sub> air quality objective of 200µg/m<sup>3</sup> (not to be exceeded more than 18 times per year) is unlikely to be exceeded at roadside locations where the annual mean concentration is less than 60µg/m<sup>3</sup>. Results presented in Section 5 will be screened using these criteria.

### 3.8 Assessment criteria

No formal significance criteria have been used for this assessment, results will however be compared against Table 2.1.

### 3.9 Assumptions and limitations

The air quality modelling predictions are associated with an inherent level of uncertainty, primarily a result of:

- Uncertainties with traffic data
- Uncertainties with vehicle emission predictions
- Uncertainties with background air quality maps

Model uncertainty can be addressed through the process of model verification. Model verification is a two-step process. Firstly, modelled concentrations are compared with monitored concentrations to identify any disparity. Where disparity occurs, the model inputs are revisited to identify any potential errors or opportunity for improvement of the model. Where disparity remains following the first step, model results can be adjusted to account for systematic bias.

A requirement of model verification is air quality monitoring data in a location that is similar, in terms of road traffic and layout, to the dispersion site and where traffic data for a proposed development is available. In this instance, although NCC do undertake air quality monitoring adjacent to the M4 there was uncertainty of their true locations which could not be clarified by a desk-based study. There were no representative monitoring locations adjacent to fast busy roads in MCC either. On this basis, it has not been possible to carry out a quantitative model verification with the process described above. For the purposes of this assessment, NO<sub>2</sub> model outputs, presented in Section 5.2, have been increased by a factor of 2. A factor which is considered to be highly conservative based on previous project experience and is therefore considered to be robust.

---

<sup>30</sup> Department for Environment Food and Rural Affairs (2021). Local Air Quality Management (LAQM) website, available at: <https://laqm.defra.gov.uk/air-quality/air-quality-assessment/nox-to-no2-calculator/>



## 4 Baseline

### 4.1 Overview

Information on air quality in the UK can be obtained from a variety of sources including local authorities, national network monitoring sites and other published sources. For the purposes of this assessment, data has been obtained from Defra<sup>31</sup>, MCC<sup>32</sup>, and NCC<sup>33</sup>.

The most recent full year of monitoring data available for the monitoring sites operated by MCC is 2022, Defra is 2021, and NCC is 2021. The monitoring data for 2021 however is unlikely to be representative of 'normal' conditions at the monitoring sites, due to the effects associated with the coronavirus (Covid-19) pandemic during those years when England was subject to periods of lockdowns and the influences this had on traffic. Therefore, the data for 2021 is presented for reference only and the most recent year with representative data for MCC is 2022 and for Defra and NCC is both 2019.

### 4.2 Local authority review and assessment

#### 4.2.1 Air Quality Management Areas

MCC has declared two AQMAs in its administrative area, Usk AQMA and Chepstow AQMS, both located over 10km away from the proposed Gypsy & Travellers Site. NCC has declared over 13 AQMAs in its administrative area. The closest AQMA in NCC is located approximately 7km away from the site. All AQMAs located in MCC and NCC are in urban locations and therefore not representative of the Proposed Gypsy & Travellers Site. The proposed development will not impact any of the AQMAs and therefore are not considered further.

#### 4.2.2 Local authority monitoring

##### 4.2.2.1 Automatic monitoring

MCC undertook automatic monitoring at one site within its administrative area in 2022. The monitoring site is located approximately 12km northeast to the proposed Gypsy & Travellers Site but is not considered to be representative of the site as it is located near the urban area of Chepstow. However, NCC undertook automatic monitoring at two sites within its administrative area in 2021. Both AN1 and AN2 are located 10km to the west of the proposed Gypsy & Travellers Site. Both are considered to be more representative due to their location adjacent to the M4 motorway. AN1 measured NO<sub>2</sub>, PM<sub>10</sub>, and PM<sub>2.5</sub> and AN2 measured NO<sub>2</sub> only, as seen in Table 4.1. However, The Annual Progress Report (2022) for NCC is missing annual mean NO<sub>2</sub> automatic data for both sites, therefore the automatic monitoring that is undertaken at a monitoring station that is part of the Automatic Urban and Rural Network (AURN) operated by Defra has been used. The location of the AURN monitoring site (UKA00380) is in a similar location to AN1. The monitoring station is located over 10km to the west of the proposed Gypsy & Travellers Site. The locations can be seen in Figure 4.1.

---

<sup>31</sup> Department for Environment Food and Rural Affairs. Air Quality Information Resource (Air) Website. Available at: <http://uk-air.defra.gov.uk/>

<sup>32</sup> Monmouthshire County Council (2023) Air Quality Annual Status Report

<sup>33</sup> Newport City Council (2022) Air Quality Annual Status Report

**Table 4.1: Automatic monitoring results**

Site ID	Site Type	Council Name	Approx. distance from the proposed development (km)	National Grid Reference		Pollutant	Annual mean NO <sub>2</sub> concentration (µg/m <sup>3</sup> )/ Exceedances of Short-Term Objective (-) * or Annual mean PM <sub>10</sub> concentration (µg/m <sup>3</sup> )/ Exceedances of Short-Term Objective (-) #				
				X	Y		2018	2019	2020	2021	2022
UKA00380 / AN1	Urban Background	NCC	10	332418	189603	NO <sub>2</sub>	15 (-)	35 (-)	33 (-)	21 (-)	21 (-)
UKA00380 / AN1	Urban Background	NCC	10	332418	189603	PM <sub>10</sub>	14 (0)	15 (0)	13 (0)	12 (0)	-
UKA00380 / AN1	Urban Background	NCC	10	332418	189603	PM <sub>2.5</sub>	8 (0)	10 (0)	8 (0)	7 (0)	-

Source: Newport City Council, LAQM Annual Progress Report (2022) [Local Authority Details - Defra, UK](#)

Note: Dash (-): no monitoring data available.

**Figure 4.1: Automatic monitoring locations**



Page 811

Note: Although not data is presented within Table 4.1 relating to Site AN2, it has been added to the figure for reference only

#### 4.2.2.2 Diffusion tube monitoring

MCC undertook NO<sub>2</sub> diffusion tube monitoring at 49 sites across their administrative boundary in 2022. However, these are located on the roadside within the urban area of Chepstow, therefore not representative of our site. However, NCC undertook NO<sub>2</sub> diffusion tube monitoring at 81 tubes across their administrative boundary in 2021. The closest diffusion tubes have been selected as shown in Table 4.2. These are considered to be representative of the site due to their location near the M4 motorway. The location of these diffusion tubes is shown in Figure 4.2. The results show that there were no exceedances at any of the monitoring sites between 2018 and 2021 except for NCC21d, NCC23e which had exceedances in 2018, 2019, and 2020.

**Table 4.2: Diffusion tube monitoring results**

Site ID	Site Type	Council Name	Approx. distance from the proposed development (km)	National Grid Reference		Annual mean NO <sub>2</sub> concentration (µg/m <sup>3</sup> )				
				X	Y	2018	2019	2020	2021	2022
NCC16a	Roadside	NCC	10.0	332320	189703	28.2	27.5	22.6	21.8	-
NCC21d, NCC23e	N/A	NCC	10.0	332690	189615	<b><u>54.6</u></b>	<b><u>48.5</u></b>	<b><u>46.7</u></b>	34.7	-
NCC37, NCC38, NCC39	Background	NCC	10.0	332499	189569	18.6	18.5	14.4	13.5	-
NCC31	Façade	NCC	7.0	334951	189237	36.7	35.6	29.9	26.6	-
1S1	N/A	NCC	10.0	332320	189702	-	-	-	20.6	-
1S2	Roadside	NCC	10.0	332312	189702	-	-	-	18.9	-

Source: Newport City Council, LAQM Annual Progress Report (2022)

Note: Dash (-): no monitoring data available.

Exceedances shown in bold and underlined

N/A no information about the official site type available from local authority, however due to assumed to be roadside to motorway

Figure 4.2: Diffusion tube locations

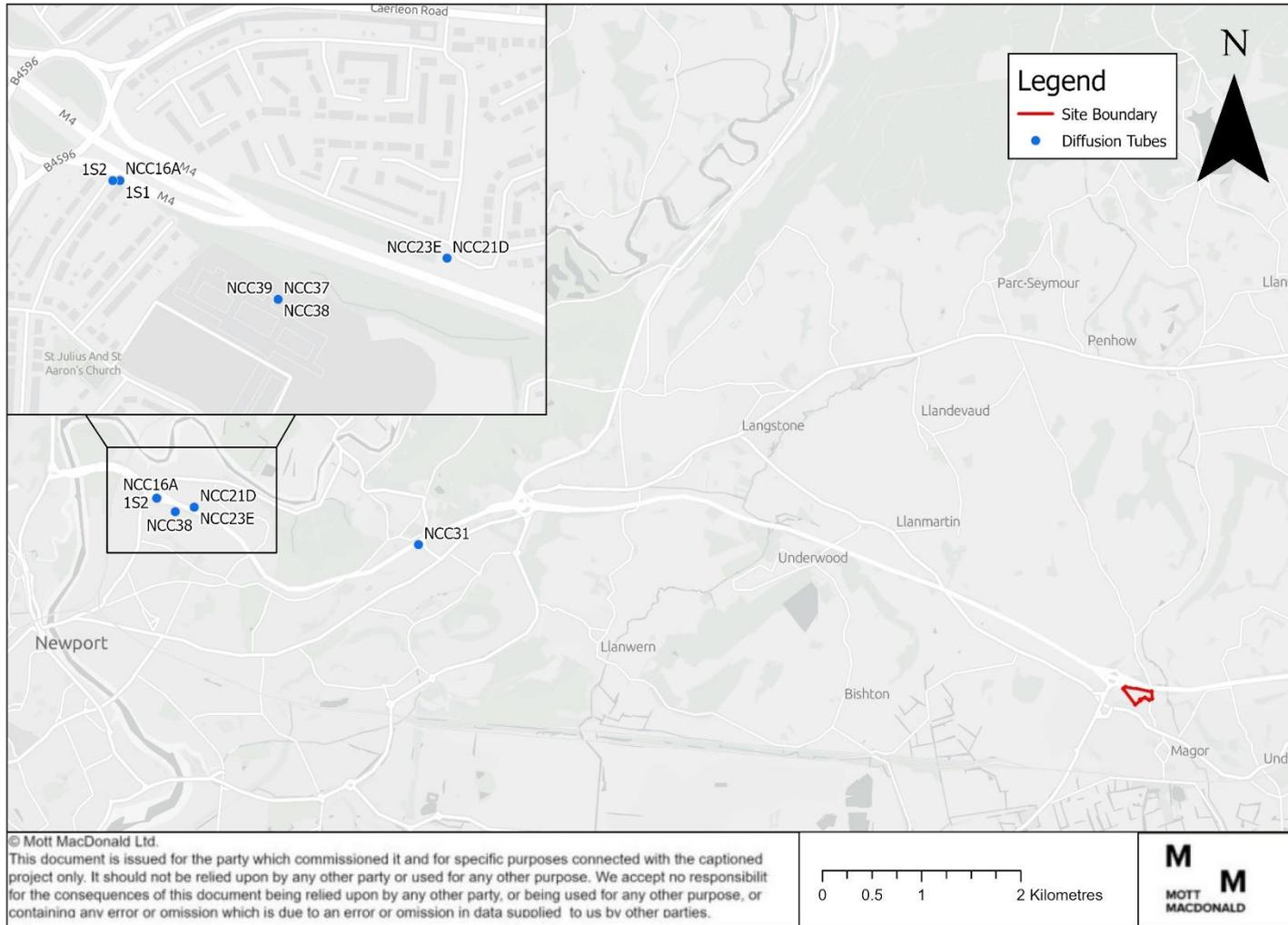

Page 814

### 4.3 Defra projected background concentrations

Defra provides mapped future year projections of background pollution concentrations for NO<sub>x</sub>, NO<sub>2</sub>, PM<sub>10</sub> and PM<sub>2.5</sub> for each one kilometre (km) grid square across the UK for all years between 2018 to 2030<sup>34</sup>. The maps include a breakdown of background concentrations by emission source, including road and industrial sources, which have been calibrated against 2018 (the baseline year) UK monitoring data. Table 4.3 presents the background concentrations for the 1km grid square containing the proposed Gypsy & Travellers Site in the current year of 2024. The background concentrations at the proposed Gypsy & Travellers Site are all within the relevant objectives. Table 4.3 presents the background concentrations for the 1km grid square containing the proposed Gypsy & Travellers Site in the baseline year of 2019.

**Table 4.3: Defra projected background concentrations of NO<sub>x</sub>, NO<sub>2</sub>, PM<sub>10</sub>, PM<sub>2.5</sub>, for proposed development in 2024 (µg/m<sup>3</sup>)**

1km Grid Square Location (OS Grid Reference)		2024 background concentration (µg/m <sup>3</sup> )			
X	Y	NO <sub>2</sub>	NO <sub>x</sub>	PM <sub>10</sub>	PM <sub>2.5</sub>
342500	187500	10.2	13.3	13.3	8.5

Source: <https://uk-air.defra.gov.uk/data/laqm-background-maps?year=2018>

**Table 4.4: Defra projected background concentrations of NO<sub>x</sub>, NO<sub>2</sub>, PM<sub>10</sub>, PM<sub>2.5</sub>, for proposed development in 2019 (µg/m<sup>3</sup>)**

1km Grid Square Location (OS Grid Reference)		2019 background concentration (µg/m <sup>3</sup> )			
X	Y	NO <sub>2</sub>	NO <sub>x</sub>	PM <sub>10</sub>	PM <sub>2.5</sub>
342500	187500	13.1	17.5	14.1	9.1

Source: <https://uk-air.defra.gov.uk/data/laqm-background-maps?year=2018>

### 4.4 Pollution Climate Model (PCM)

Defra uses the Pollution Climate Model (PCM) to report compliance with the limit values transposed into UK law from the Air Quality Directive<sup>35</sup>. PCM projections of NO<sub>2</sub> concentrations are available for all years from 2018 to 2030 from the base year of 2018. In general, predicted NO<sub>2</sub> concentrations decline into the future, mainly in response to cleaner vehicles and technologies, and actions in Air Quality Action Plans by local and combined authorities. The most recent PCM model results were published in 2020 and the projections represent the projected concentrations assuming no further action beyond the air quality measures that were committed by the reference year (2018).

The PCM links located closest to the proposed Gypsy & Travellers Site are displayed in Figure 4.3 below. The PCM model predicts the greatest 2024 annual mean NO<sub>2</sub> concentration of 26.2 µg/m<sup>3</sup>, located at census ID 802010500. This is well below the annual mean limit value of 40µg/m<sup>3</sup> for NO<sub>2</sub>. On this basis, the risk of a limit value non-compliance or delaying compliance with limit values is low and is therefore not considered further.

<sup>34</sup> Defra Background maps (2018) [Online]. Available at: <https://uk-air.defra.gov.uk/data/laqm-background-maps>

<sup>35</sup> 2. European Union. (April 2008) Directive on Ambient Air Quality and cleaner Air for Europe, Directive 2008/50/EC Official Journal, vol. 152, pp. 0001-0044

**Figure 4.3: Nearby PCM links**

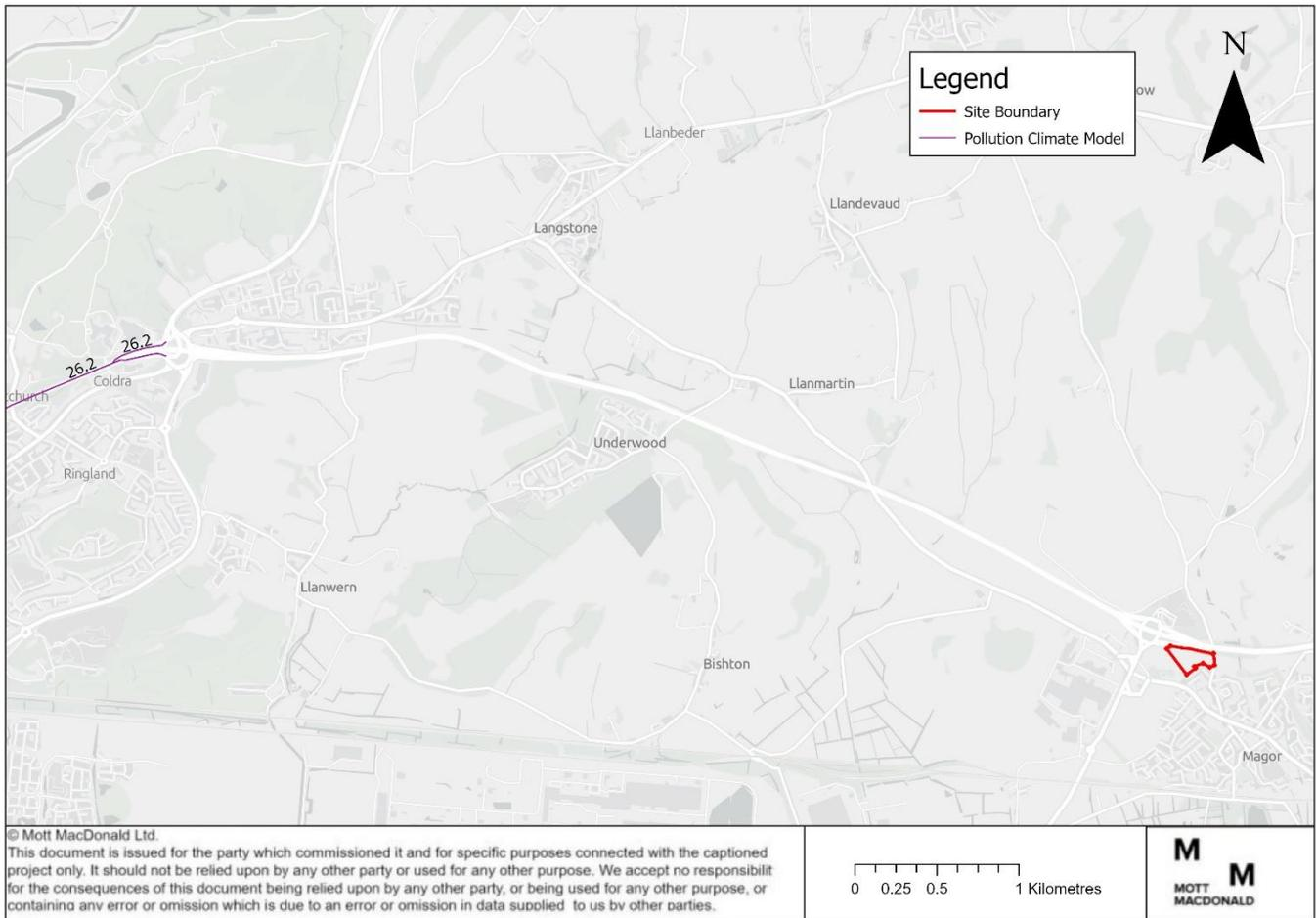

#### 4.5 Local emission sources

The main source of local emissions that could adversely impact the proposed Gypsy & Travellers Site is the M4 motorway immediately surrounding north of the site and the A4810 immediately to west of the site. An existing rail line is located 650m south to the proposed Gypsy & Travellers Site. It is not expected that there will be any significant impact from diesel train movements on ambient air quality. In accordance with guidance produced by Defra (TG22)<sup>26</sup>, exceedances of the NO<sub>2</sub> annual mean objectives nearby to rail line are unlikely if the background annual mean NO<sub>2</sub> concentration is well under 25µg/m<sup>3</sup>, as is the case here. A review of the Defra’s UK Pollutant Release and Transfer Register public register<sup>36</sup> shows there is one installation permits issued within 1km of the proposed Gypsy & Travellers Site. The AB InBev Limited, Magor Brewery is located to the west of the proposed Gypsy & Travellers Site. There is no data reported regarding release to air, water or soil.

#### 4.6 Summary

The proposed Gypsy & Travellers Site is a roadside background location, given that it is located approximately 20m away from the nearest motorway, the M4 motorway. As such, the urban background monitoring site AN1 and AN2 are considered to be representative as they are located next to M4 motorway. Further, the roadside diffusion tubes selected in Section 4.2.2.2

<sup>36</sup> Defra. Available at: [Search by map - Defra, UK](#)



were also considered to be the most representative due to the proposed Gypsy & Travellers Site location next to the motorway. Both automatic sites show data that is far below the objective of  $40\mu\text{g}/\text{m}^3$ . As such, it is unlikely that the addition of roadside  $\text{NO}_2$  concentrations associated with the proposed Gypsy & Travellers Site would lead to an exceedance of the annual mean  $\text{NO}_2$  objective.

The annual mean  $\text{PM}_{10}$  concentration recorded at AN1 are also well below the objective of  $40\mu\text{g}/\text{m}^3$ . The  $\text{PM}_{2.5}$  concentration recorded at both of the monitoring sites is also far below the applicable standard of  $20\mu\text{g}/\text{m}^3$ . Given that recorded  $\text{PM}_{10}$  and  $\text{PM}_{2.5}$  monitored concentrations are well below the relevant objectives these pollutants have not been considered further within this report.

#### 4.7 Mitigation

As the site is considered suitable for the proposed users, no additional mitigation measures are expected to be required. However, it should be ensured that the policies relating to air quality outlined in the Monmouthshire Local Plan and Newport Local Plan, as detailed in Section 2.3.2, are considered within the design and operation of the proposed Gypsy & Travellers Site.

## 5 Potential Impacts

### 5.1 Overview

This section presents the air quality impacts predicted to occur at sensitive receptor locations due to the operation of the proposed Gypsy & Travellers Site. Results are presented for the opening year of 2024 as this is predicted to be the worst case.

### 5.2 Site suitability

Table 5.1 presents the predicted changes and resultant annual mean NO<sub>2</sub> pollutant concentrations at the worst-case receptors for the proposed Gypsy & Travellers Site, presented within Table 3.2.

**Table 5.1: Predicted impacts on NO<sub>2</sub> concentrations at the proposed Gypsy & Travellers Site and sensitive receptors**

ID	2024 annual mean NO <sub>2</sub> (µg/m <sup>3</sup> )	Annual mean NO <sub>2</sub> objective (µg/m <sup>3</sup> )
R1	23.5	40.0
R2	20.9	40.0
R3	21.9	40.0

Table 5.1 highlights that results are well below the NO<sub>2</sub> annual mean objective of 40 µg/m<sup>3</sup> at the worst-case receptors. It can therefore be considered that the proposed Gypsy & Travellers Site is suitable, in terms of air quality, for the introduction of additional receptors.

### 5.3 Mitigation

Considering the predicted air quality impact of the proposed Gypsy & Travellers Site are predicted to be suitable for the introduction of additional receptors, no additional mitigation measures are expected to be required.

## 6 Conclusions

This report provides an assessment of the suitability of the proposed Gypsy & Travellers Site for the future proposed users.

A review of the existing air quality information indicates that exceedances of the 1-hour mean NO<sub>2</sub>, 24-hour mean PM<sub>10</sub> and annual mean NO<sub>2</sub>, PM<sub>10</sub> and PM<sub>2.5</sub> objectives are unlikely at the proposed Gypsy & Travellers Site. At receptors, chosen to represent the worst-case locations on the proposed Gypsy & Travellers Site, are predicted to be well below the NO<sub>2</sub> objective. The proposed Gypsy & Travellers Site is therefore considered suitable for the proposed users in terms of long-term and short-term exposure to pollutant concentrations.

Results presented within this report are not considered to conflict with any national, regional or local planning policy.

This page is intentionally left blank

## Proposed Gypsy and Traveller Site, Bradbury Farm, Crick

### Site description

There are 12 dwellings to the Southeast perimeter of the site, all of which adjoin the proposed site along the boundary. The second closest dwellings are around 20M+ from the edge of the site. The site will be a new noise source to the area.

## Noise

### **Part 1- Clarification on methodology**

The following points need addressing in the report;

1. There are limitations to deriving the Day and Nighttime dBA at each short-term location from the LT data, in that this method does not define the contours of noise level exposure distributed throughout the site. This is usually provided as part of an acoustic assessment to determine site suitability.
2. The acoustic consultant has indicated BS4142 assessments were undertaken within their report, it is unclear as to the reasoning to include such an assessment within this context, as the proposed site use would be classified as residential as opposed to industrial or commercial, notwithstanding that the site would become a new noise source.
3. Whilst there were suggested noise mitigation measures of earth-bundling and acoustic barriers, the extent and specification of these measures were not determined. Please consider specific noise modelling for the site to determine the indicative extent and effectiveness of suggested mitigation measures for the site.
4. The acoustic report makes reference to the ProPG Planning guidance. This guidance relates specifically to English planning policy, with TAN 11 forming the Welsh approach.

Overall, I consider that the methodology of the baseline noise survey is suitably robust and representative of the noise exposure, having regard to the sampling locations, duration of both (long term) noise sampling period, and in particular the timing of the short-term noise recordings.

It is worth noting that the sample at this site erred on the side of caution at Langley Close as the short term (ST) measurements were undertaken during morning rush hour times. Again, the long term (LT) sampling erred towards worst case scenario, being undertaken a few days before Christmas. Compounding this, there is traffic to and from large businesses, a large national retail distribution centre and a large brewery utilising the M4 off-ramp and also the A4810, respectively at the North and West boundaries of the proposed site.

**Part 2- Relevant standards applicable to the site and summary of NIA findings**

**TAN11**

	Noise Exposure Category (L <sub>Aeq,T</sub> dB)			
Source: road traffic	A	B	C	D
0700-2300 Day time	<55	55-63	63-72	>72
2300-0700 Nighttime	<45	45-57	57-66	>66

Source: Taken from Table 2: Recommended Noise Exposure Categories For New Dwellings Near Existing Noise Sources <https://www.gov.wales/sites/default/files/publications/2018-09/tan11-noise.pdf>

“**Green border - NEC B.** Noise should be taken into account when determining planning applications and where appropriate, conditions imposed to ensure an adequate level of protection.

**Orange border - NEC C.** Planning permission should not normally be granted. Where it is considered that permission should be given, for example because there are no alternative quieter sites available, conditions should be imposed to ensure a commensurate level of protection against noise.”

Figure below has been taken from February 2024 Mott MacDonald: Proposed Gypsy and Traveller Site, Langley Close, Magor “Figure 5.1: Areas within TAN 11 NEC categories”, page 18.



Considering TAN 11 as above - with specific regard to the area falling within NEC ‘C’ – this is a very large (albeit unspecified) portion of the site footprint and would limit the number of pitches as planning consent is recommended to be ruled out of these areas without enforceable noise mitigation planning conditions in place.

Activity	Location	07:00 to 23:00	23:00 to 07:00
Resting	Living room	35dB LAeq, 16hrs	-
Dining	Dining room/area	40dB LAeq, 16 hrs	-
Sleeping (daytime resting)	Bedroom	35 dB LAeq, 16 hrs	30dB LAeq, 8 hrs

Source: Taken from BS8233:2014 'Sound insulation and noise reduction for buildings – Code of Practice'

### **BS8233 Internal criteria**

The report makes reference that a mobile home may provide a sound insulation value of around 15dB to 20dB with the windows closed. In this case a 15dB reduction can be seen to have been the reduction calculated within this report and this aligns with the MCC approach.

**Therefore, when included for a 15dB closed window reduction, without other noise mitigation; the site average noise levels measured were (at LT1 LAeq of 45dB daytime) and (LAeq of 40.5dB nighttime), (at ST1 LAeq of 45.5dB daytime) and (LAeq of 41dB nighttime), (at ST4 LAeq of 41dB daytime) and (LAeq of 37dB nighttime).**

**All areas significantly exceed the BS8233 Internal criteria standards for daytime or nighttime noise levels for noise sampling locations within NEC'B'. Noise levels substantially exceeded the recommended levels at the North and Eastern NEC 'C' sampling locations.**

### **The BS8233 External criteria**

In the case of gardens and external amenity areas, BS 8233 advises that a level of **LAeq,T 50 dB is desirable and that a level of LAeq,T 55 dB should be considered an upper limit.**

**Measured noise levels at all NEC 'B' locations on the site exceeded the upper limit of 55dB LAeq,T value recommended by BS 8233 for external amenity areas (LT1 being 60.dB, ST1 being 60.5dB and ST4 being 56.4dB). The equivalent average noise measurements were substantially above the recommended noise levels at both of the North and Eastern NEC 'C' sampling locations.**

It would therefore be necessary to provide localised noise screening for the outdoor amenity areas. This may take the form of solid noise barriers or landscaped bunds between the M4 and the residential plots of the site. These measures would need to be of significant height in order to achieve the desired exterior level of 50 dB LAeq,T especially at the eastern end of the site.

### **Part 3- Proposed mitigation and further information required.**

The areas of the proposed site that fall in the NEC C should not be developed for accommodation or outdoor living area. The NEC B area of the site, TAN11 states that "Noise

should be taken into account when determining planning applications and where appropriate, conditions imposed to ensure an adequate level of protection”.

**Measured noise levels at all locations on the site exceeded the noise LAeq,T values recommended by BS 8233 for both indoor standards and external amenity area standards.** It would therefore be necessary to provide localised noise screening to achieve compliance in any area of the site. This may take the form of solid noise barriers or landscaped bunds between the M4 and the residential plots of the site. This barrier would need to be of significant height in order to achieve the desired exterior level of 50 dB LAeq,T especially at the eastern end of the site.

Proposed earth bunds and acoustic barriers have been suggested as possible mitigation for the site against traffic noise emanating from the M4 and the A4810. However, the proposed sound mitigation needs to be modelled on the site to ensure it can meet both internal and external BS 8233 standards. This should also inform the overall cost of mitigation and the overall viability of the proposed site for the number of pitches under consideration.

### Air Quality

An air quality assessment was undertaken by Mott Macdonald in February 2024. A qualitative review of local and national air quality monitoring data and a qualitative Design Manual for Roads and Bridges (DMRB) calculation spreadsheet assessment using Department for Transport traffic count from 2022 for the M4, M4 slip road and A4810. That traffic data was then used with emission factors from DEFRA's Emission Factor Toolkit (EFT) based on traffic flows, speeds, and vehicle emission factors.

For Langley Close the consultants used three worst-case locations as the receptors the northwestern corner adjacent to south of the M4, as there are currently no plans highlighting the exact locations of the proposed accommodation areas.

As this is a model/calculation rather than monitoring, there will be uncertainties which the assessment highlights (e.g. traffic data, emission predictions, background air quality).

Model uncertainty can be improved by model verification (i.e. comparing the model against monitored concentrations to improve the model at other locations by adjusting for systematic bias). However, in this case the consultant did not do this, as they were not sure of the exact monitoring locations that they had identified as being carried out by Newport Council along a similar stretch of the M4. Instead, they increased the model outputs by a factor of 2.

It would be preferable to undertake a proper quantitative model verification by either visiting the locations of the monitoring to determine exact potions, or phoning Newport Council to ask for more exact locations.

However, the Consultants state that a factor of 2 is highly conservative based on their previous project experience.

The assessment presents monitoring data from automatic monitoring stations and diffusion tubes alongside the M4. One of the diffusion tubes exceeded the nitrogen dioxide objective level (annual mean) in 2018,2019 and 2020 however the report does not state their distance from the M4 – and if this is comparable to the distance of the proposed site from the M4. As mentioned above none of this monitoring data is used to verify the model in any case but does



provide some monitoring information further west along the M4 (although how relevant that is could be debatable without corresponding traffic flows, and distance to the monitoring locations).

The model used DEFRA background concentrations (based on 1km grid square) for a 1km square for both 2024 and 2019. These are all well below the NO<sub>2</sub> annual mean objective level of 40 µg/m<sup>3</sup> (10.2 µg/m<sup>3</sup> in 2024 and 13.1 µg/m<sup>3</sup> in 2019).

The assessment also mentions DEFRA's Pollution Climate Model (PCM) which is used to report compliance with the Air Quality Directive limit values. The closest location for the PCM however is by the Coldra Roundabout. That model predicts current (2024) NO<sub>2</sub> to be 26.2µg/m<sup>3</sup>. Again, this was not used in the model verification for the site but provides further context/information about potential NO<sub>2</sub> concentrations along the M4.

The report concludes that the site is surrounded north by the M4 (20 metres), and the A4810 immediately to the west, and that therefore the two automatic monitors and the diffusion tubes operated by Newport Council are relevant as they are located next to the M4. The report states that the automatic monitors show data far below the objective level of 40 µg/m<sup>3</sup>. This is the case for 2022 – where concentrations were 21 µg/m<sup>3</sup>, but not for 2019 when concentrations were 35 µg/m<sup>3</sup>. In addition, one diffusion tube exceeded the objective level in 2018 (54.6), 2019 (48.5), and 2020 (46.7) and was 34.7 in 2021 with no data obtained for 2022 or 2023.

The report states that the predicted impact on NO<sub>2</sub> concentrations at the proposed site will be between 20.9 µg/m<sup>3</sup> and 23.5 µg/m<sup>3</sup>.

## **Conclusions**

- The locations of the monitoring were not obtained to undertake a qualitative model verification, it would be more robust to obtain this information and undertake verification.
- Exceedances and near exceedances of monitored locations were not considered as relevant and were not provided with any context e.g. how they compare to the proposed site in terms of distance to the road, traffic flows, congestion etc.
- No discussion as to if Newport have undertaken any localised actions that resulted in improved concentrations that between 2018 and 2022 to improve air quality.
- Assuming the predicted impacts given in Table 5.1, are the modelled concentrations of NO<sub>2</sub> at those locations, and that they have been multiplied by a factor of 2, it would indicate that the original model predicted 10-12 µg/m<sup>3</sup>, which is below the 1km square background concentrations.
- As the receptor is only 20m south of the M4, it would be expected that concentrations would be higher than the 1km average. It is appreciated that due to a lack of verification the concentrations were doubled, but the model does not give confidence in the actual concentrations at the site, nor the fact that in the recent past,

concentrations at M4 roadside locations in Newport were close or exceeded the NO<sub>2</sub> annual mean objective level.

I would agree that the site would not impact local air quality (due to the number of proposed pitches) however I am uncertain that the highest concentration of nitrogen dioxide that would be experienced anywhere on the site is 10.1 µg/m<sup>3</sup>.

### Contaminated Land

Mott Macdonald undertook a desktop study and site walk over to produce the land contamination assessment in February 2024. An intrusive site investigation (soil/water/gas sampling) was not undertaken.

Based on the desktop study and site walk over a conceptual site model to identify potential contamination linkages, a preliminary risk assessment and recommendations were produced.

Historically the site has been an undeveloped field since the first map version (1879), with the only changes being offsite i.e. a quarry 200m to the south-west in 1800, and the construction of the M4 immediately to the north in 1966-1970.

Radon is a potential issue (3-5% likelihood of exceedance of the action level) on the site if utility blocks are built.

The report did not consider services or utilities buried beneath the site. A utility search would be required prior to development. An animal water trough and alkathene supply pipe were present.

Based on the desk study and site walk over, the report considered that there are no specific sources of contamination identified, with the only evidence of land disturbance being the animal water troughs fed by a water supply pipe, a metal caravan, and potential buried redundant water supply pipes.

The report considers it likely that topsoil is present across the whole site, and that significant thicknesses of made ground are not anticipated, however localised Made Ground might be present along the northern boundary associated with construction of the M4, and on the south-eastern boundary adjacent to the residential development.

The report considered that ground gas potential is not significant, however if deposits of organic materials are encountered during development, the risk should be further assessed.

The Preliminary Conceptual Site Model does not highlight any significant consequences from the site; however, this does assume a transient population, and therefore a low likelihood of residents growing produce.

The report does not consider progressing to an intrusive ground investigation, however if any unforeseen ground conditions are encountered during development, work must stop, and the risks reassessed.

This is reasonable, however If the council considers the assumptions that residents will have no contact with soil and will not grow produce to be incorrect, it would be appropriate for some soil samples to be taken for laboratory analysis of contaminants prior to development. It would be reasonable to exclude the northern section of the site – adjacent to the M4, and southeastern boundary next to the residential development, from being landscaped, or available for growing produce, due to the CL assessment's consideration of the possibility of made ground in these areas. In addition, there could be a greater concentration of atmospheric pollution deposition in this area from the use of the M4.

All other recommendations (Section 7.2) should also be followed, including utility survey, radon search, and production of a discovery strategy (to plan for the discovery of unforeseen contamination).

This page is intentionally left blank

## Proposed Gypsy and Traveller Site, Bradbury Farm, Crick

### Noise

#### Part 1- Clarification on methodology

1. There are x2 ST3 positions listed on the map however believe one of them should be ST4 (page 19)
2. Advised that southern eastern corner of the site chosen to used  $L_{Aeq,16hour}$  for the BS 8233 assessment criteria, however it appears to have come from the LT baseline monitoring for the assessment located at LT1 rather than positioning ST3. This place is furthest from the M48 therefore likely to be the quietest part of the site which is not necessarily representative to the site unless that is the only location of proposed pitches.
3. Table 4.2 summary refers to 15 minute recordings although 5 minute recordings have been undertaken.
4. ProPG is an English planning standard, however reference to BS 8233 (page 20) said a 3dB  $L_{Aeq,8hrs}$  although this should be 30dB.
5. Reference for a barrier/bund along the southern boundary of the site closest to the M48, however the M48 is north of the site (page 21)
6. Uncertain how 60m from the M48 and 20m from the Crick Road would put that part of the site in TAN 11 NEC B, can't see the workings/modelling in the report that shows how they got to that conclusion
7. Understand how they've worked out the Day and Nighttime dBA at each short-term location from the LT data, however, I am not uncertain as to whether this is a recognised method.

#### Part 2- Relevant standards applicable to the site and summary of NIA findings

##### TAN11

	Noise Exposure Category ( $L_{Aeq,TdB}$ )			
Source: road traffic	A	B	C	D
0700-2300 Day time	<55	55-63	63-72	>72
2300-0700 Nighttime	<45	45-57	57-66	>66

Source: Taken from Table 2: Recommended Noise Exposure Categories For New Dwellings Near Existing Noise Sources <https://www.gov.wales/sites/default/files/publications/2018-09/tan11-noise.pdf>

**“NEC B.** Noise should be taken into account when determining planning applications and where appropriate, conditions imposed to ensure an adequate level of protection.

**NEC C.** Planning permission should not normally be granted. Where it is considered that permission should be given, for example because there are no alternative quieter sites available, conditions should be imposed to ensure a commensurate level of protection against noise.”

Figure below has been taken from February 2024 Mott MacDonald: Proposed Gypsy and Traveller Site, Bradbury Farm, Crick “Figure 5.1: Areas within TAN 11 NEC categories”, page 19.



### BS8233 Internal criteria

Activity	Location	07:00 to 23:00	23:00 to 07:00
Resting	Living room	35dB LAeq, 16hrs	-
Dining	Dining room/area	40dB LAeq, 16 hrs	-
Sleeping (daytime resting)	Bedroom	35 dB LAeq, 16 hrs	30dB LAeq, 8 hrs

Source: Taken from BS8233:2014 'Sound insulation and noise reduction for buildings – Code of Practice'

The report makes reference to a mobile home may provide a sound insulation value of around 15dB to 20dB with windows closed. "Calculated Leq, 16hour levels in the southeastern corner of the site were 56.6dB during daytime and 53.0dB at night". From the reduction of noise from the caravan of 15-20dB provides internal day time levels of 41.6dB- 36.6dB and nighttime 38dB-33dB. Therefore, without any noise mitigation to the site, the lowest level (caravans providing a 20dB reduction in sound) are unable to meet BS8233 Internal criteria standards for daytime or nighttime for any activity or location.

### The BS8233 External criteria

On the basis that it will be necessary to achieve the internal limits with open windows during warmer months, an open window provides a typical sound reduction of 10 – 15 dB. From this, it may be extrapolated that external limit levels for open windows are as follows:

- Daytime - LAeq,T 50 – 55 dB
- Night time - LAeq,T 45 – 50 dB

In the case of gardens and external amenity areas, BS 8233 advises that a level of LAeq,T 50 dB is desirable and that a level of LAeq,T 55 dB should be considered an upper limit. These values correlate with the derived daytime external limit values.

*“Calculated Leq,16hour levels in the southeastern corner of the site were 56.6dB during daytime and 53.0dB at night”.* This is furthest away from the M48 and Crick Road, the location does not meet the external daytime upper limit of 55dB or external nighttime upper limit of 50dB without sound mitigation in situ.

The nearest dwelling to the edge of the site is around 65m with Crick Road between the dwelling and the site. The second closest dwellings are around 100m from the edge of the site with the M48 in-between. There is also a solar farm to the east of the proposed site. The site will be a new noise source to the area.

### **Part 3- Proposed mitigation and further information required**

The areas of the proposed site that fall in the NEC C should not be developed for accommodation or outdoor living area. The NEC B area of the site, TAN11 states that “Noise should be taken into account when determining planning applications and where appropriate, conditions imposed to ensure an adequate level of protection”.

Proposed earth bunds have been suggested as possible mitigation for the site and they are likely to be more effective for Crick Road rather than against traffic noise emanating from the M48. However, the proposed sound mitigation needs to be modelled on the site to ensure it can meet both internal and external BS 8233 standards. This should also inform the siting for the proposed 6 pitches.

### **Air Quality**

An air quality assessment was undertaken by Mott Macdonald in February 2024. A qualitative review of local and national air quality monitoring data and a qualitative Design Manual for Roads and Bridges (DMRB) calculation spreadsheet assessment using Department for Transport traffic count from 2022 for the M48. That traffic data was then used with emission factors from DEFRA’s Emission Factor Toolkit (EFT) based on traffic flows, speeds, and vehicle emission factors.

For Bradbury Farm the consultants used a worst-case location as the receptor the northwestern corner adjacent to Crick Road and the M48, as there are currently no plans highlighting the exact locations of the proposed accommodation areas.

As this is a model/calculation rather than monitoring, there will be uncertainties which the assessment highlights (e.g. traffic data, emission predictions, background air quality).

Model uncertainty can be improved by model verification (i.e. comparing the model against monitored concentrations to improve the model at other locations by adjusting for systematic bias). However, in this case the consultant did not do this, as they were not sure of the exact monitoring locations that they had identified as being carried out by Newport Council along a similar stretch of the M4. Instead, they increased the model outputs by a factor of 2.

I would have preferred that they undertook a proper quantitative model verification by either visiting the locations of the monitoring to determine exact potions, or phoning Newport Council to ask for more exact locations.

However the Consultants state that a factor of 2 is highly conservative based on their previous project experience.

The assessment presents monitoring data from automatic monitoring stations and diffusion tubes alongside the M4. One of the diffusion tubes exceeded the nitrogen dioxide objective level (annual mean) in 2018, 2019 and 2020 however the report does not state their distance from the M4 – and if this is comparable to the distance of the proposed site from the M48. As mentioned above none of this monitoring data is used to verify the model in any case but does provide some monitoring information further west along the M4 (although how relevant that is could be debatable without corresponding traffic flows, and distance to the monitoring locations).

The model used DEFRA background concentrations (based on 1km grid square) for two 1km squares for both 2024 and 2019. These are all well below the NO<sub>2</sub> annual mean objective level of 40 µg/m<sup>3</sup> (6.7, 6.1 in 2024 and 8.4, 8.2 in 2019).

The assessment also mentions DEFRA's Pollution Climate Model (PCM) which is used to report compliance with the Air Quality Directive limit values. The closest location for the PCM however is by the Coldra Roundabout. That model predicts current (2024) NO<sub>2</sub> to be 26.2 µg/m<sup>3</sup>. Again this was not used in the model verification for the site, but provides further context/information about potential NO<sub>2</sub> concentrations along the M4.

The report concludes that the site is 20m south of the M4 motorway (possibly a typo and they mean the M48), and that therefore the two automatic monitors and the diffusion tubes operated by Newport Council are relevant as they are located next to the M4. The report states that the automatic monitors show data far below the objective level of 40 µg/m<sup>3</sup>. This is the case for 2022 – where concentrations were 21 µg/m<sup>3</sup>, but not for 2019 when concentrations were 35 µg/m<sup>3</sup>. In addition, one diffusion tube exceeded the objective level in 2018 (54.6), 2019 (48.5), and 2020 (46.7) and was 34.7 in 2021 with no data obtained for 2022 or 2023.

The report states that the predicted impact on NO<sub>2</sub> concentrations at the proposed site will be 10.1 µg/m<sup>3</sup>, which is 3.5 µg/m<sup>3</sup> higher than 2024 background and 1.5 µg/m<sup>3</sup> higher than 2019 background.

### **Further Information Required**

- The locations of the monitoring were not obtained to undertake a qualitative model verification.
- Exceedances and near exceedances of monitored locations were not considered as relevant and were not provided with any context e.g. how they compare to the proposed site in terms of distance to the road, traffic flows, congestion etc.
- No discussion as to if Newport have undertaken any localised actions that resulted in improved concentrations that between 2018 and 2022 to improve air quality.
- What does the predicted impact of 10.1 µg/m<sup>3</sup> mean? Is it an increase of 10.1 µg/m<sup>3</sup> or is 10.1 µg/m<sup>3</sup> the predicted NO<sub>2</sub> concentration at the modelled receptor?
- Is 10.1 µg/m<sup>3</sup> the actual modelled concentration, or is it multiplied by a factor of 2 due to the lack of model verification? If so, did the model originally predict 5 µg/m<sup>3</sup>, which would be lower than the general 1km square background concentrations. As the receptor is only 20m south of the M48, it would be expected that concentrations would be higher than the 1km average.



I would agree that the site would not impact local air quality (due to the number of proposed pitches) however I am uncertain that the highest concentration of nitrogen dioxide that would be experienced anywhere on the site is  $10.1 \mu\text{g}/\text{m}^3$ .

### Contaminated Land

Mott Macdonald undertook a desktop study and site walk over to produce the 7land contamination assessment in February 2024. An intrusive site investigation (soil/water/gas sampling) was not undertaken.

Based on the desktop study and site walk over a conceptual site model to identify potential contamination linkages, a preliminary risk assessment and recommendations were produced.

Historically the site has been an undeveloped field since the first map version (1881), with the only changes being offsite i.e. railway line 200m to the west in 1965, and the M4 to the construction of the M4 20 metres to the north in 1967.

Radon is a potential issue (3-5% likelihood of exceedance of the action level) on the site if utility blocks are built.

The report did not consider services or utilities buried beneath the site. A utility search would be required prior to development. A manhole cover labelled 'water' and animal troughs were present, which would be associated with buried pipes.

Base on the desk study and site walk over, the report considered that there are no specific sources of contamination identified, with the only evidence of land disturbance being the utility manhole in the north-west and the animal water troughs fed by a water supply pipe.

The report considers it likely that topsoil is present across the whole site, and that significant thicknesses of made ground are not anticipated, however localised Made Ground might be present along the northern boundary associated with construction of the M4 (now M48), and in the vicinity of the water main.

The report considered that ground gas potential is not significant, however if deposits of organic materials are encountered during development, the risk should be further assessed.

The Preliminary Conceptual Site Model does not highlight any significant consequences from the site; however, this does assume a transient population, and therefore a low likelihood of residents growing produce.

The report does not consider progressing to an intrusive ground investigation, however if any unforeseen ground conditions are encountered during development, work must stop, and the risks reassessed.

This is reasonable, however If the council considers the assumptions that residents will have no contact with soil and will not grow produce to be incorrect, it would be appropriate for some

soil samples to be taken for laboratory analysis of contaminants prior to development. It would be reasonable to exclude the northern section of the site – adjacent to the M48, from being landscaped, or available for growing produce, due to the CL assessment's consideration of the possibility of made ground in this area. In addition, there could be a greater concentration of atmospheric pollution deposition in this area from the use of the M48.

All other recommendations (Section 7.2) should also be followed, including utility survey, radon search, and production of a discovery strategy (to plan for the discovery of unforeseen contamination).

## Proposed Gypsy and Traveller Site, Oak Grove Farm, Portskewett

### Site Description

The site is currently agricultural fields on the north side of the B5245 road, Nr Crick. The A48 road lies 130m north of northern boundary of the site. The noise environment at the southern end of the site is dominated by road traffic on the B4245 road whilst the northern end of the site is dominated by road traffic noise from the B4245 road and also the A48 road.

The nearest neighbouring residential property is 20m to the south east of the site with agricultural holdings to the south east, north and north west.



### Clarification on methodology

12 days of unattended 'long-term' monitoring was conducted between 9<sup>th</sup> and 21<sup>st</sup> December 2023 and further 'short-term' attended monitoring between 13:45 and 16:00 on 5<sup>th</sup> January 2024. Variation in noise levels across the site has been assessed by calculating the average difference between results at the long-term monitoring position and short-term monitoring positions. The methodology described is acceptable in principle and assessments conducted in line with relevant standards, however appendix B LT1 columns are incorrectly labelled and the assessed noise levels across the site should be better presented by means of zonal mapping.

### Standards And Summary of the Site

#### TAN11

	Noise Exposure Category			
Source: road traffic	A	B	C	D
0700-2300 Day time	<55	55-63	63-72	>72
2300-0700 Nighttime	<45	45-57	57-66	>66
Source: Taken from Table 2: Recommended Noise Exposure Categories For New Dwellings Near Existing Noise Sources <a href="https://www.gov.wales/sites/default/files/publications/2018-09/tan11-noise.pdf">https://www.gov.wales/sites/default/files/publications/2018-09/tan11-noise.pdf</a>				

NEC B. Noise should be taken into account when determining planning applications and where appropriate, conditions imposed to ensure an adequate level of protection.

NEC C. Planning permission should not normally be granted. Where it is considered that permission should be given, for example because there are no alternative quieter sites available, conditions should be imposed to ensure a commensurate level of protection against noise.

**Comments:** The report indicates that the majority of the site falls within NEC B with the exception of a strip of land closest to the B5245 road (shown below) which falls within NEC C. Therefore, in line with TAN 11, the area shown as NEC C should not be granted permission for the proposed use.

Figure 5.1: Areas within Tan 11 NEC Categories



Source: Mott MacDonald

**BS8233 Internal Noise Criteria are as follows:**

In general, for steady external noise sources, it is desirable that the internal ambient noise level of a dwelling does not exceed the following guideline values:

Activity	Location	07:00 to 23:00	23:00 to 07:00
Resting	Living room	35dB LAeq, 16hrs	-
Dining	Dining room/area	40dB LAeq, 16 hrs	-
Sleeping (daytime resting)	Bedroom	35 dB LAeq, 16 hrs	30dB LAeq, 8 hrs

Source: Taken from BS8233:2014 'Sound insulation and noise reduction for buildings – Code of Practice'

The internal and external noise guidance of BS 8233:2014 is based on research by the World Health Organisation.

The report states that it is estimated that a mobile home may provide a sound insulation value of around 15dB to 20dB with windows closed.

Taking account of a 15dB attenuation of a mobile home with closed windows the predicted internal noise levels at:

- 95m from the B5245 road were found to be 41dBLAeq,16hr during daytime and 35dBLAeq,8hr at night. **These are above the internal noise level recommendations provided by BS 8233.**
- The Northern most point, furthest from the B5245 are predicted to be 39dB LAeq,16hr daytime and 33dB LAeq,8hr at night. **These levels still exceed the internal recommendations of BS8233.**

NOTE 7 of BS8233 provides that 'Where development is considered necessary or desirable, despite external noise levels above WHO guidelines, the internal target levels may be relaxed by up to 5 dB and reasonable internal conditions still achieved.'

#### **The BS8233 External Noise Criteria are as follows:**

In the case of gardens and external amenity areas, BS 8233 advises that it is desirable that the external noise level does not exceed 50 dB LAeq,T, **with an upper guideline value of 55 dB LAeq,T which would be acceptable in noisier environments.**

Average daytime noise levels were found to be 55.8dB LAeq at 95m from the B4245. Further assessment could be undertaken to give a better indication of average noise levels closer to the road and across the site as a whole.

#### **World Health Organisation Guidelines For Community Noise 1999**

The report explains that 'The World Health Organization (WHO) Guidelines for Community Noise and Night Noise Guidelines provides guidance on maximum noise levels within residential dwellings during nighttime periods which can cause sleep disturbance. Guidance advises that internal noise levels should not exceed 45dB LAMax,f (not to be exceeded 10 to 15 times a night) due to individual events.' However, whilst figure 4.1 of the report provides a graph of the LAMax the report does not provide sufficient analysis of individual night-time noise events such as the noise impact of individual vehicles driving passed the site.

#### **Proposed Mitigation and Further Mitigation**

The report indicates that interior and external noise levels would exceed the recommended noise levels given in BS 8233 across the whole site. The report suggests that an earth bund or solid noise barrier constructed along the southern edge of the site may help achieve the internal noise criteria within mobile homes and external noise guidelines of BS 8233 in the NEC B area of the site, or localised noise screening for the outdoor amenity areas to help achieve exterior noise levels.

*Error noted:* The report recommends 'If planning permission is granted, a Stage 2 Acoustic Assessment should be conducted in which the landscape design of the proposed site should be developed to incorporate acoustic screening for the plots closest to the north-eastern corner.' This is incorrect, as the predominant noise source is on the southern edge.

On this basis of the report, it is considered that the northern NEC B part of the site may be suitable for development as a Gypsy and Traveler Site provided mitigation measures are implemented.

### **Officers View**

Whilst at this stage exceedances of noise criteria are indicated across the whole site, some of the exceedances could be considered marginal. At this stage, I would recommend further investigation into potential mitigation measures be conducted as part of the application process, including the design and effectiveness of an earth bund, solid barrier to the southern edge of the site or localised screening in achieving desired noise levels in line with the criteria described above. Such investigation should report on noise modelling and noise zonal mapping across the whole site.

**April 2024**  
**Replacement Local Development Plan**  
**Gypsy & Traveller Accommodations Housing Sites**  
**Langley Close, Magor**  
**Oak Grove Farm, Crick**  
**Bradbury Farm Crick**

**Site - Oak Grove Farm, Portskewett, Caldicot**

**April 2024**  
**Technical Note – Land at Oak Grove Farm, Crick – prepared by AECOM dated 09/02/2024**

The Technical Note submitted in support of the site has been considered and the highway authority generally agree with the Report's Conclusions and Recommendations.

A suitable means of access that accords with current design standards is achievable of the B4245, Reference Appendix A.

The highway authority offers no objection to the proposed development of a maximum of 6 Gypsy and Traveller Pitches, the proposal would not be detrimental to the safety and capacity of the adjacent local highway network.

Unfortunately, the site location is not considered to be a sustainable transport location and it is acknowledged that no improvements are considered as part of the proposal therefore the site will be solely reliant on the domestic car for trips to and from the site.

It is recommended that the views and observations of Active travel and Transport colleagues are considered when considering the suitability of the site.

### **November 2023**

The proposed site for a maximum of 6 pitches directly abuts the B4245 a classified highway and a strategic route providing access to Chepstow, Caldicot and the A48, A466 & M48 to the east and the M4 to the west.

- Traffic Impact – Due to the size, scale, and type of development the impact of the development is considered negligible on the immediate local highway network. The B4245 is considered to be more than capable of accommodating the traffic movements associated with the size and scale development proposed.
- Access – A suitable means of access is considered achievable directly off the B4245 that accords with current local and national design standard.
- Site Accessibility – Generally, the highway authority considers the site to be poorly located, the immediate area is not considered the most sustainable location in terms of attractors and amenities and is considered to be too far outside of Portskewett/Caldicot/Chepstow to encourage walking and cycling.
- Pedestrian & Cycle Provision – no footways or cycling links are available on the immediate local highway, B4245.
- Public Transport – No bus stops are located on the B4245 in the vicinity of the site

The highway authority offers no objection to the proposed development of a maximum of 6 Gypsy and Traveller Pitches, the proposal would not be detrimental to the safety and capacity of the adjacent local highway network, however the location is not considered to be a sustainable transport location.

A transport statement/technical note and detailed access drawings would be required to support any future consideration/application.

**Site – Bradbury Farm, Crick Road, Crick, Caldicot  
April 2024**

**Technical Note – Land at Bradbury Farm, Crick – prepared by AECOM dated 15/03/2024**

The Technical Note submitted in support of the site has been considered and the highway authority agree with the Report's Conclusions and Recommendations.

It is acknowledged that a suitable site access directly off Crick Road is achievable, but the exact location will be subject to further consideration due to visibility requirements, however as detailed the status of Crick Road may well be subject to significant change as the site direct abuts the proposed Bradbury Farm & Sow Ground candidate sites in the Revised Local Development Plan.

It is recognised that the sites lack of walking/Cycling and sustainable transport provision would be significantly enhanced if the site were developed alongside the proposed Bradbury Farm & Sow Ground candidate sites in the Revised Local Development Plan

**November 2023**

The proposed site for a maximum of 6 pitches directly abuts route R139, Crick Road a un-numbered classified highway and a strategic route providing access to and from the A48 and B4245, providing further to the A466 & M48 to the east and the M4 to the west.

- Traffic Impact – Due to the size, scale, and type of development the impact of the development is considered negligible on the immediate local highway network Route R139, Crick Road is considered to be more than capable of accommodating the traffic movements associated with the size and scale development proposed. The proposal is also considered to be capable of being accommodated / incorporated into any potential re-engineering of the immediate local network if and when the Caldicot strategic sites are progressed.
- Access – A suitable means of access is considered achievable directly off route R139, Crick Road a un-numbered classified highway that accords with current local and national design standard.
- Site Accessibility – Generally, the highway authority considers the site to be poorly located, the immediate area is not considered the most sustainable location, however with the implementation and delivery of the Caldicot Strategic site then this will be significantly improved.
- Pedestrian & Cycle Provision – no footways or cycling links are available on the immediate local highway however with the implementation and delivery of the Caldicot Strategic site then this will be significantly improved.
- Public Transport – No bus stops are located on Crick Road or within reasonable walking distance, however this will likely be addressed if and when then Caldicot Strategic site is delivered.



The highway authority offers no objection to the proposed development as the proposal would not be detrimental to the safety and capacity of the adjacent local highway network, currently the location is not considered to be a sustainable transport location, however this will be significantly improved when the Caldicot Strategic site is delivered.

A transport statement/technical note and detailed access drawings would be required to support any future consideration/application.

---

### **5.79 Acres, Langley Close, Magor**

**April 2024**

#### **Technical Note – Land To Rear of Langley Close, Magor – prepared by AECOM dated 09/02/2024**

The Technical Note submitted in support of the site has been considered and the highway authority generally agree with the Report's Conclusions and Recommendations.

The proposed means of access as detailed in Appendix A meets with current design standards and the highway authority acknowledge that additional off site measures on Route R133 St Brides Road are required to achieve the required design standards in particular the extension of the 20mph speed limit.

The highway authority offers no objection to the proposed development of a maximum of 6 Gypsy and Traveller Pitches, the proposal would not be detrimental to the safety and capacity of the adjacent local highway network.

#### **November 2023**

The proposed site for 46 traveller pitches directly abuts Route R133 St Brides Road a classified un-numbered road and benefits from an existing access from St Brides Road via a standard field gate.

- **Traffic Impact** – Due to the size, scale, and type of development the impact of the development will have a significant impact on the safety and capacity of the immediate local network, in particular Route R133 St Brides Road and its junction with the B4245. On site highway improvements are considered likely over the site's frontage with Route R133 St Brides Road.
- **Access** – the site currently benefits from access via a field gate from Route R133 St Brides Road. The existing access is not capable of being improved to provide an access that accords with current standards, therefore a new means of access located at a suitable position along the site boundary abutting Route R133 St Brides Road will be required to facilitate access to the proposed development of circa 46 or less traveller pitches. The new access that accords with current design standards is achievable directly off Route R133 St Brides Road but will result in considerable loss of the existing boundary hedge to accommodate the access, footway and visibility splays etc.



- 
- Site Accessibility – Generally, the highway authority considers the site to be reasonably well located albeit on the periphery of Magor but is considered to have reasonable walking and cycling links to all of Magors main attractors and amenities.
- Pedestrian & Cycle Provision – The proposed site benefits from reasonable off site pedestrian and cycling provision on St Brides Road.
- Public Transport – Bus stops are located on the B4245 within reasonable walking distance of the site, approximately 400metres.

The highway authority considers the proposed site to be well located and accessible for all modes of transport and as detailed the increase in vehicular and sustainable traffic can be accommodated on the adjacent local highway network with little or no off-site improvements. A transport assessment and detailed access drawings would be required to support any future application.

I have reviewed the survey information for the three sites in relation to biodiversity and have summarised below:

#### Bradbury Farm, Crick

Majority of the site comprised poor semi-improved grassland managed by grazing sheep. **Priority habitat on site includes broadleaved woodland and hedgerows.** The woodland is located to the north of the site stretching to the M48. Hedgerows bound the east, south and west of the site – the hedgerow along the eastern boundary is newly planted and species poor, whilst the hedgerows along the south and west boundaries were notably gappy and also species poor. Numerous scattered trees are also present along site boundaries.

**Potential presence of roosting bats (mature trees) badger (woodland), breeding birds (hedgerows, woodland, trees) and hazel dormice (hedgerows/woodland) was noted.** Therefore, it is possible that further survey work will be required depending on the extent of the finalised proposals. The impact of lighting on such habitats will also need to be considered.

The ability of the site to deliver an overall net benefit for biodiversity must be considered. The status of the hedgerows and woodland mean that there should be scope to enhance these habitats via planting and ongoing management.

#### Langley Close, Magor

Around half of the site comprises poor semi-improved grassland, with bare ground comprising much of the rest of the site. **Priority habitat on site includes broadleaved woodland and hedgerows.** The woodland is located along the north of the site. Other boundaries comprise species-poor hedgerows with mature trees.

**Potential presence of roosting bats (mature trees) badger (woodland), breeding birds (hedgerows, woodland, trees) and hazel dormice (hedgerows/woodland) was noted.** Therefore, it is possible that further survey work will be required depending on the extent of the finalised proposals. The impact of lighting on such habitats will also need to be considered.

The ability of the site to deliver an overall net benefit for biodiversity must be considered. The status of the hedgerows and woodland mean that there should be scope to enhance these habitats via planting and ongoing management.

#### Oak Grove Farm, Portskewett

The two fields comprise improved and semi-improved grassland of low ecological value. **Priority habitat on site is limited to the hedgerows around the site boundaries.** All hedgerows were noted to be in a defunct or species-poor condition.

**Potential presence of roosting bats (mature trees) and breeding birds (hedgerows, trees) was noted.** Therefore, it is possible that further survey work will be required depending on the extent of the finalised proposals. The impact of lighting on such habitats will also need to be considered. The site is located within 2km of the Severn Estuary SPA but the small size of the site and poor quality habitat means that impacts to qualifying features are unlikely (but nevertheless should be considered).

The ability of the site to deliver an overall net benefit for biodiversity must be considered. The status of the hedgerows mean that there should be scope to enhance these habitats via planting and ongoing management.

### Conclusion

From the submitted information, Oak Grove Farm appears to be of the lowest ecological value with no woodland located within the site boundary. Nevertheless, further survey work may be required at all three sites depending upon the extent of the proposals.

Planning Policy Wales (PPW) 12 sets out that “planning authorities must seek to maintain and enhance biodiversity in the exercise of their functions. This means that development should not cause any significant loss of habitats or populations of species, locally or nationally and must provide a net benefit for biodiversity” (para 6.4.5 refers). This policy and subsequent policies in Chapter 6 of PPW 12 respond to the Section 6 Duty of the Environment (Wales) Act 2016. The chosen site must be able to demonstrate that it has the ability to provide an overall net benefit as per PPW 12 prior to determination.

Kind regards

### **Daniel Hulmes**

Biodiversity & Ecology Officer / Swyddog Bioamrywiath ac Ecoleg

Monlife

Monmouthshire County Council / Cyngor Sir Fynwy

Mob:07815 015460

Email: [danielhulmes@monmouthshire.gov.uk](mailto:danielhulmes@monmouthshire.gov.uk)



<b>Name of the Officer completing the evaluation</b>  Ian Bakewell  <b>Phone no:</b> 01633 644479 <b>E-mail:</b> <a href="mailto:ianbakewell@monmouthshire.gov.uk">ianbakewell@monmouthshire.gov.uk</a>	<b>Please give a brief description of the aims of the proposal</b>  Meeting The Unmet Pitch Needs of the Gypsy and Traveller Assessment January 2021.  Proposal for Bradbury Farm to be developed as a Gypsy and Traveller Site
<b>Name of Service area</b> Housing & Communities	<b>Date</b>  7th July 2023 updating 31 <sup>st</sup> August 2021 Version  6 <sup>th</sup> November 2023 Updated Version  28 <sup>th</sup> June 2024

1. **Are your proposals going to affect any people or groups of people with protected characteristics?** Please explain the impact, the evidence you have used and any action you are taking below.

Protected Characteristics	Describe any positive impacts your proposal has on the protected characteristic	Describe any negative impacts your proposal has on the protected characteristic	What has been/will be done to mitigate any negative impacts or better contribute to positive impacts?
Age	<p>The proposal will positively contribute to the Gypsy and Traveller community.</p> <p>Children and young people will be more likely to receive stable accommodation to ensure that they can enjoy a decent standard of living and reach their potential.</p>	<p>Some of the previously shortlisted sites are used as recreation space, the loss of which would have impacted negatively on young people in particular. This is not applicable to the proposal in respect of Bradbury Farm.</p>	<p>The Council has and will continue to engage with the Travelling Ahead advocacy service. The completed public consultation helped to assess the potential impact relating to different site options.</p>
Disability	<p>Members of the travelling community can be provided with more appropriate accommodation. This can also help access to health and care services.</p>	<p>There were no negative impacts in respect of the completed consultation, although the feedback identified by the consultation about Langley Close, Bradbury Farm and Oakgrove being developed as Gypsy and Traveller sites was that the sites were not considered to be suitable.</p> <p>Future site design can consider disability standards.</p>	<p>Ensure that sites, when developed, are fully accessible.</p> <p>For the wider community, the completed public consultation helped to assess the potential impact relating to different site options.</p>
Gender reassignment	Positive impact	N/A	N/A

Protected Characteristics	Describe any positive impacts your proposal has on the protected characteristic	Describe any negative impacts your proposal has on the protected characteristic	What has been/will be done to mitigate any negative impacts or better contribute to positive impacts?
Marriage or civil partnership	As above	As above	As above
Pregnancy or maternity	The identification of new sites should have a positive impact on those who are pregnant as giving better access to pre-natal care and provide more stable accommodation for the family.	As above	As above

Protected Characteristics	Describe any positive impacts your proposal has on the protected characteristic	Describe any negative impacts your proposal has on the protected characteristic	What has been/will be done to mitigate any negative impacts or better contribute to positive impacts?
Race	<p>Romany Gypsies and Irish Travellers are recognised as having a protected characteristic under the Equality Act 2010. The identification of new sites providing permanent authorised accommodation will have a positive impact on this community in terms of education, health and quality of life. The Council has a zero tolerance to the use of any racist, discriminatory or prejudiced remarks or feedback.</p>	As above	<p>Many people express negative opinions about gypsies and travellers and work will be needed to counter these negative perceptions and ensure social cohesion. Racist comments and behaviour will be reported to the Police.</p> <p>Inappropriate or discriminatory comments were excluded from the consultation feedback.</p> <p>A separate event was provided for members of the Gypsy and Traveller community to ensure they have a safe space to obtain information and provide feedback.</p> <p>As a 'critical friend' the advocacy agency Travelling Ahead, have been fully involved in the site identification and consultation process. Their involvement, however, did not intend to be representative of any Gypsy and Traveller household or the Gypsy and Traveller Community. Travelling Ahead were not employed by the Council.</p>
Religion or Belief	Positive impact	As above	As above



<b>Protected Characteristics</b>	<b>Describe any positive impacts your proposal has on the protected characteristic</b>	<b>Describe any negative impacts your proposal has on the protected characteristic</b>	<b>What has been/will be done to mitigate any negative impacts or better contribute to positive impacts?</b>
Sex	As above	As above	As above
Sexual Orientation	As above	As above	As above

**2. The Socio-economic Duty and Social Justice**

The Socio-economic Duty requires public bodies to have due regard to the need to reduce inequalities of outcome which result from socio-economic disadvantage when taking key decisions This duty aligns with our commitment as an authority to Social Justice.

	<b>Describe any positive impacts your proposal has in respect of people suffering socio economic disadvantage</b>	<b>Describe any negative impacts your proposal has in respect of people suffering socio economic disadvantage.</b>	<b>What has been/will be done to mitigate any negative impacts or better contribute to positive impacts?</b>

<p><b>Socio-economic Duty and Social Justice</b></p>	<p>It is recognised that Gypsy and Travellers can be disadvantaged in part, due to lack of stable accommodation, including available permanent pitch provision, resulting in a more transient lifestyle due to the need to regularly move on.</p> <p>This can be detrimental to community inclusion including accessing (or retaining) employment/training opportunities and accessing financial services e.g. insurance.</p> <p>Good quality permanent pitch provision also supports wider priorities such education, particularly for children and young people, as well as health and well-being.</p>	<p>There are no negative impacts associated with this proposal to consult on the suitability of Council owned land.</p> <p>However, there would be negative impacts if the Council determined not to develop any of the identified land.</p> <p><b>Dancing Hill</b> – this is currently tenanted for horse grazing, which would impact negatively on the tenant’s employment and income. This was withdrawn from the process by Cabinet on 4<sup>th</sup> October 2023.</p> <p>Concerns have been expressed about negative impacts about property values. These are not material planning considerations.</p> <p><b>Bradbury Farm</b> - forms part of the Council's County Farms estate and is occupied via an agricultural tenancy. It is anticipated this tenancy would need to be amended should the site be supported for this use.</p>	<p>There is no current mitigation against the identified employment detriment relating to possible development of Dancing Hill. Should it be selected then mitigating actions can be considered. This was withdrawn from the process by Cabinet on 4<sup>th</sup> October 2023.</p> <p>There is no current mitigation against the possible impact on property values of neighbouring homes. Should any be selected be selected then any possible mitigating actions would need to be investigated.</p> <p>The Council has previously established a pitch waiting list and allocation policy in potential readiness for pitch provision. This, however, needs to be reviewed and published. This provides a mechanism for households to apply for future pitches. It’s also a positive mechanism for the Council to engage with the Gypsy and Traveller community.</p> <p>Should a decision be made on any of Langley Close, Bradbury Farm or Oakgrove Farm sites for development, mitigating action would need to be investigated.</p>
--	--	---	--

**Commented [CF1]:** Do we need to include Dancing Hill in this version, given that it was withdrawn in October 2023?

How does your proposal impact on the following aspects of the Council's Welsh Language Standards:	Describe the positive impacts of this proposal	Describe the negative impacts of this proposal	What has been/will be done to mitigate any negative impacts or better contribute to positive impacts
<b>Policy Making</b> Effects on the use of the Welsh language, Promoting Welsh language Treating the Welsh language, no less favourably	The Council has a pitch allocation policy, and it is appropriate to establish a bi-lingual version.	None	N/A
<b>Operational</b> Recruitment & Training of workforce	Neutral impact. This proposal does not involve the appointment of staff.	None	N/A
<b>Service delivery</b> Use of Welsh language in service delivery Promoting use of the language	Whilst the current proposal to consult on potential pitch provision has a neutral impact, in the longer term, the aim is to establish Gypsy and Traveller pitch provision. This is an opportunity to promote the Welsh Language e.g. signage, agreements, welcome packs etc.	None	N/A

### 3. Policy making and the Welsh language.

**4. Does your proposal deliver any of the well-being goals below?** Please explain the impact (positive and negative) you expect, together with suggestions of how to mitigate negative impacts or better contribute to the goal. There's no need to put something in every box if it is not relevant!

Well Being Goal	Does the proposal contribute to this goal? Describe the positive and negative impacts.	What actions have been/will be taken to mitigate any negative impacts or better contribute to positive impacts?
<p><b>A prosperous Wales</b> Efficient use of resources, skilled, educated people, generates wealth, provides jobs</p>	<p>Meeting the pitch needs of Gypsy and Traveller households creates stability for households and enables them to establish firm links with local communities e.g. schools, employment.</p> <p>It reduces the likelihood of unauthorized encampments and the associated resource implications of dealing with such.</p> <p><b>Dancing Hill</b> - this is currently tenanted for horse grazing, which would impact negatively on the tenant's employment and income. This is no longer applicable further to Cabinet 4<sup>th</sup> October 2023.</p> <p><b>Langley Close</b> - is currently tenanted for horse grazing, which would impact negatively on the tenant's employment and income, although it is proposed to withdraw Langley Close from the process.</p> <p><b>Oakgrove Farm</b> - forms part of the Council's County Farms estate and is occupied via an agricultural tenancy. It is anticipated this tenancy would need to be amended should the site be supported for this use, although this is not proposed.</p>	<p>There is no current mitigation against the identified employment detriment relating to possible development of Dancing Hill. Should it be selected then mitigating actions can be considered. This is no longer applicable further to Cabinet 4<sup>th</sup> October 2023.</p> <p>We will involve and liaise with Travelling Ahead, Gypsy and Traveller advocates.</p> <p>Should a decision be made on any of Langley Close, Bradbury Farm or Oakgrove Farm sites for development, mitigating action would need to be investigated.</p>

Well Being Goal	Does the proposal contribute to this goal? Describe the positive and negative impacts.	What actions have been/will be taken to mitigate any negative impacts or better contribute to positive impacts?
	<p><b>Bradbury Farm</b> - forms part of the Council's County Farms estate and is occupied via an agricultural tenancy. It is anticipated this tenancy would need to be amended should the site be supported for this use.</p>	
<p><b>A resilient Wales</b> Maintain and enhance biodiversity and ecosystems that support resilience and can adapt to change (e.g., climate change)</p>	<p>Ecological site surveys have identified there will be a need to consider this in respect of the design and development of a possible public provision. This is considered to be an opportunity to achieve improvements that benefit the biodiversity and ecosystems.</p>	<p>Any site development proposal will take into account all requirements and recommendations relating to the Ecological site surveys and feedback from the Councils Ecology Team. Further surveys may be needed to inform any future Planning applications.</p>
<p><b>A healthier Wales</b> People's physical and mental wellbeing is maximized, and health impacts are understood</p>	<p>There were no negative impacts associated with this proposal to consult on the suitability of Council owned land.</p> <p>However, it has been suggested an alternative option for the use of the <b>Langley Close</b> land is for recreational purposes. Should this location be used for Gypsy and Traveler pitch provision, this could impact upon the possible alternative recreational option. Although it is proposed that Langley Close is withdrawn from the site identification process as it is less suitable than the preferred option of Bradbury Farm.</p> <p>It was also suggested that an existing footpath across Dancing Hill could be an Active Travel route. Possible use for Gypsy and Traveller</p>	<p>To mitigate against unintended detrimental consequences that may impact on the Gypsy and Traveler community, the site consultation that commenced on 9th November 2023 was similar in approach to the Replacement Local Development Plan consultation in respect of candidate sites e.g. the use of drop-ins and a questionnaire.</p> <p>The Council would be keen to involve potential resident households of any future site design, to provide an opportunity to influence design proposals. The Council wants Gypsy and Traveller households to want to live on a site and regard it as 'home.'</p>

Well Being Goal	Does the proposal contribute to this goal? Describe the positive and negative impacts.	What actions have been/will be taken to mitigate any negative impacts or better contribute to positive impacts?
	<p>pitch provision may impact detrimentally on the possible Active Travel route option. This is no longer applicable as Dancing Hill has been withdrawn.</p> <p>Facilitating pitch provision supports good quality accommodation for Gypsy and Traveller households which is conducive to good health and well-being and helps tackle health inequalities. It also supports households being able to access health services e.g. GP's, dentists, opticians etc.</p>	
<p><b>A Wales of cohesive communities</b> Communities are attractive, viable, safe and well connected</p>	<p>The potential to facilitate the availability of new pitch provision provides the opportunity to invest in appropriately located and well-designed provision that is attractive to the Gypsy &amp; Traveller community and has no impact on existing communities.</p>	<p>To mitigate against unintended detrimental consequences that may impact on the Gypsy &amp; Traveller community, the site consultation that commenced on 9th November 2023 was similar in approach to the Replacement Local Development Plan consultation in respect of candidate sites e.g. the use of drop-ins and a questionnaire.</p> <p>The Council is keen that any sites developed are well designed and landscaped, developed to a high standard and not detrimental to local settings. Site development will be based on Welsh Government design guidance.</p> <p>Site evaluation surveys (including noise, land contamination, air quality and transport) completed have helped to inform whether there</p>

Well Being Goal	Does the proposal contribute to this goal? Describe the positive and negative impacts.	What actions have been/will be taken to mitigate any negative impacts or better contribute to positive impacts?
		are any potential safety or 'connection]' issues. This information has been used to inform this proposal to recommend Bradbury Farm to be put forward for development.
<b>A globally responsible Wales</b> Taking account of impact on global well-being when considering local social, economic and environmental wellbeing	N/A	N/A.
<b>A Wales of vibrant culture and thriving Welsh language</b> Culture, heritage and Welsh language are promoted and protected. People are encouraged to do sport, art and recreation	Should the Council's site identification result in public pitch provision, this presents an opportunity to promote the Welsh Language.	Consultation material was bi-lingual.
<b>A more equal Wales</b> People can fulfil their potential no matter what their background or circumstances	The proposals directly support equality and protected and or disadvantaged groups.	As above.

**4. How has your proposal embedded and prioritised the sustainable governance principles in its development?**

Sustainable Development Principle	Does your proposal demonstrate you have met this principle? If yes, describe how. If not explain why.	Are there any additional actions to be taken to mitigate any negative impacts or better contribute to positive impacts?
 <p>Long Term future</p> <p>Balancing short term need with long term and planning for the</p>	<p>The proposal is informed by a Gypsy and Traveller Assessment Jan 21, which makes population projections up to 2033.</p> <p>Planning for pitch provision helps to reduce the likelihood of unauthorised encampments. If the resulting outcome to meet need is public provision, households will be able to apply to live there.</p>	<p>The continued engagement with Travelling Ahead advocacy service.</p> <p>Future Gypsy and Traveller pitch assessments.</p> <p>The Council is proposing to establish a negotiated stopping arrangement to mitigate against unauthorised encampments, which although separate to the site investigation work, is integral to the Council's approach to supporting the Gypsy &amp; Traveller Community.</p>
 <p>Collaboration</p> <p>Working together with other partners to deliver objectives</p>	<p>The proposals will be developed with Welsh Government and Gypsy and Traveller advocates including Travelling Ahead and a specialist planning consultant.</p> <p>The Council if applicable will engage with Welsh Government in respect of potential funding.</p> <p>Although not applicable at present, but there could be scope to include other organisations e.g. RSL's, although no decision has been made at present,</p>	<p>Gypsy and Traveller Households themselves are key stakeholders. It's important that households want to live on potential pitches provided by the Council. Travelling Ahead have provisionally agreed to support Gypsy and Traveller households to access the Council's consultation and the drop-in at County Hall that was held as part of the consultation.</p>



Sustainable Development Principle	Does your proposal demonstrate you have met this principle? If yes, describe how. If not explain why.	Are there any additional actions to be taken to mitigate any negative impacts or better contribute to positive impacts?
 <p><b>Involvement</b></p> <p>Involving those with an interest and seeking their views</p>	<p>The proposal facilitates greater involvement with local Gypsy and Traveller households.</p> <p>There is a particular opportunity for involving families in the design of new sites.</p> <p>A robust consultation process has been undertaken in respect of a shortlist of three sites – Langley Close, Bradbury Farm and Oakgrove.</p> <p>There will be further opportunities to involve stakeholders in respect of any sites put forward for inclusion in the Deposit RLDP, which is scheduled to be consulted upon around Autumn 2024.</p> <p>Also, any planning application for an individual site will also be consulted upon.</p>	<p>Travelling Ahead have agreed to provide particular support for local Gypsy &amp; Traveller households.</p>
 <p><b>Prevention</b></p> <p>Putting resources into preventing problems occurring or getting worse</p>	<p>The proposal supports preventative activity from the perspective of households having a stable home (e.g. pitches) enabling households to better access facilities e.g. employment, education, health etc and community links.</p> <p>For the pending consultation, the Council has engaged with Travelling Ahead who have provided comments and views that the Council has utilised.</p>	<p>In respect of potential sites, site management, tenancy agreements and improved access to well-being support will be consideration.</p> <p>The Council will seek to liaise and network with other organisations who have experience of site development and management to identify good practice and options.</p>

Sustainable Development Principle	Does your proposal demonstrate you have met this principle? If yes, describe how. If not explain why.	Are there any additional actions to be taken to mitigate any negative impacts or better contribute to positive impacts?
 <p><b>Integration</b> Considering impact on all wellbeing goals together and on other bodies</p>	<p>The proposal supports increased access to good quality pitch provision that helps to provide safety, security and stability that also supports all aspects of well-being e.g. physical health, medical health etc.</p> <p>The direct benefits this has for the Gypsy and Travellers is that accommodation supports the priorities of wider agencies such as health services.</p>	<p>The site identification proposal will build upon existing services that support well-being which Gypsy &amp; Traveller households would be supported to access.</p>

5. Council has agreed the need to consider the impact its decisions has on the following important responsibilities: Corporate Parenting and Safeguarding. Are your proposals going to affect any of these responsibilities?

	Describe any positive impacts your proposal has	Describe any negative impacts your proposal has	What will you do/ have you done to mitigate any negative impacts or better contribute to positive impacts?
Safeguarding	The proposal supports households where there could be safeguarding issues by providing safe and secure pitch provision.	None.	N/A

Corporate Parenting	The proposal supports Corporate Parenting by potentially providing safe and secure pitch provision. If needed or applicable, it also supports the development of positive engagement and a relationship between any families and the Council due to there being no requirement to move on, perhaps, from an unauthorised encampment.	None.	N/A
---------------------	--	-------	-----

**6. What evidence and data has informed the development of your proposal?**

Gypsy & Traveller Assessment January 2021

Feedback from advocacy support services.

Elected member scrutiny workshops.

Elected member visit on 14<sup>th</sup> July 2023.

Pre-consultation feedback received from local councillors and members of the local community.

Post consultation feedback undertaken on behalf of the Council Nov-Dec 2023.

Individual site evaluation surveys undertaken by specialist agencies to evaluate noise, transport, air quality, land contamination and ecology.

Feedback from the Council's Environmental Health, Highways and Ecology Teams in respect of the above site evaluation surveys

**7. SUMMARY: As a result of completing this form, what are the main positive and negative impacts of your proposal, how have they informed/changed the development of the proposal so far and what will you be doing in future?**

*.This section should summarise the key issues arising from the evaluation. This summary must be included in the Committee report template*

The main benefits of the proposal are:

- It seeks to address unmet pitch need identified by the Gypsy and Traveller Assessment Jan '21
- The Council will be meeting its legal responsibilities under Part 3, Housing (Wales) Act 2014
- It supports the Gypsy and Traveller requirement relating to the development of the Replacement Local Development Plan
- It meets the expectations and requirements of Welsh Government

**8. ACTIONS: As a result of completing this form are there any further actions you will be undertaking? Please detail them below, if applicable.**

<b>What are you going to do</b>	<b>When are you going to do it?</b>	<b>Who is responsible</b>
Officer Meeting – Site identification	13 <sup>th</sup> Aug 21 – completed	Mark Hand
Officer Meeting – Site identification	19 <sup>th</sup> Aug 21 - completed	Mark Hand
Report to Enterprise DMT	6 <sup>th</sup> Sept 21	Ian Bakewell, Housing & Communities Manager
Report to Adults Select - Update report.	21 <sup>st</sup> September 21	Ian Bakewell, Housing & Communities Manager
Report to People Scrutiny	20 <sup>th</sup> July 2022	Ian Bakewell, Housing & Communities Manager
Members Workshop	29 <sup>th</sup> September 2022	Ian Bakewell, Housing & Communities Manager
Members Workshop	3 <sup>rd</sup> November 2022	Ian Bakewell, Housing & Communities Manager
Members Workshop	4 <sup>th</sup> July 2023	Ian Bakewell, Housing & Communities Manager
Report to People Scrutiny	19 <sup>th</sup> July 2023	Ian Bakewell, Housing & Communities Manager
Report to Cabinet	26 <sup>th</sup> July 2023	Ian Bakewell, Housing & Communities Manager

Report to Cabinet	4 <sup>th</sup> October 2023	Ian Bakewell, Housing & Communities Manager
Report to Place Scrutiny Committee for Call-In	23 <sup>rd</sup> October 2023	Hazel Ilett, Scrutiny Manager & Ian Bakewell, Housing & Communities Manager
Report to Full Council	26 <sup>th</sup> October 2023	
Consultation (6 weeks)	9 <sup>th</sup> November 2023	Ian Bakewell, Housing & Communities Manager
Report to Scrutiny	24 <sup>th</sup> July 2024	Ian Bakewell, Housing & Communities Manager
Report to Cabinet	21 <sup>st</sup> August 2024	Ian Bakewell, Housing & Communities Manager

**9. VERSION CONTROL: The Equality and Future Generations Evaluation should be used at the earliest stage, such as informally within your service, and then further developed throughout the decision-making process. It is important to keep a record of this process to demonstrate how you have considered and built-in equality and future generations considerations wherever possible.**

Version No.	Decision making stage	Date considered	Brief description of any amendments made following consideration
1	Report to Enterprise DMT	06.09.21	
2.	Report to People Scrutiny in preparation for Report to Cabinet	19.07.23	Utilised up to date template and updated on timeline. No changes otherwise
3.	Report to Cabinet	26.07.23	Updates to reflect initial feedback (e.g. pre proposed consultation) provided to the Council
4	Report to Cabinet	04.10.23	No changes necessary

5.	Pre-Consultation	30.10.23	Updated to reflect consideration that the pending site consultation wouldn't impact detrimental on Gypsy & Traveller households
6.	Report to Place Scrutiny Committee in preparation of Report to Cabinet on 21 <sup>st</sup> August 2024	24.07.24	Updated to reflect further iteration of the site identification process and the proposal relating to a preferred site option.